

# Purewell VariHeat he Boilers

**Cast Iron, Pre-mix, Condensing, Modular Boilers with  
Automatic Ignition for Heating and Domestic Hot Water  
Installations**

## **Installation, Commissioning and Servicing Instructions**

MODELS - 65he, 85he, 105he, 125he

*NATURAL GAS /<sub>2H</sub>*

### **IMPORTANT NOTE**

**THESE INSTRUCTIONS MUST BE READ  
AND UNDERSTOOD BEFORE INSTALLING,  
COMMISSIONING, OPERATING OR  
SERVICING EQUIPMENT**

# Customer After Sales Services

Telephone: **0845 450 2866** E-mail: **aftersales@hamworthy-heating.com** Fax: **01202 662522**

## **Technical Enquiries**

To supplement the detailed technical brochures, technical advice on the application and use of products in the Hamworthy Heating range is available from our technical team in Poole and our accredited agents.

## **Site Assembly**

Hamworthy offer a service of site assembly for many of our products in instances where plant room area is restricted. Using our trained staff we offer a higher quality of build and assurance of a boiler built and tested by the manufacturer.

## **Commissioning**

Commissioning of equipment by our own engineers, accredited agents or specialist sub – contractors will ensure the equipment is operating safely and efficiently.

## **Maintenance Agreements**

Regular routine servicing of equipment by Hamworthy service engineers inspects the safety and integrity of the plant, reducing the risk of failure and improving performance and efficiency. Maintenance agreements enable our customers to plan and budget more efficiently.

## **Breakdown service, repair, replacement**

Hamworthy provide a rapid response breakdown, repair or replacement service through head office at Poole and accredited agents throughout the UK.

## **Spare Parts**

A comprehensive spare parts service is operated from our factory in Poole, providing replacement parts for both current and discontinued products. Delivery of parts and components is normally from stock within seven days. However, a next day delivery service is available for breakdowns and emergencies.

# Purewell *VariHeat he* Boilers

**Cast Iron, Pre-mix, High Efficiency, Modular Boilers with  
Automatic Ignition for Heating and Domestic Hot Water  
Installations**

## **Installation, Commissioning and Servicing Instructions**

MODELS - 65he, 85he, 105he, 125he

*NATURAL GAS I<sub>2H</sub>*

**NOTE: THESE INSTRUCTIONS MUST BE READ AND UNDERSTOOD BEFORE  
INSTALLING, COMMISSIONING, OPERATING OR SERVICING EQUIPMENT.**

THE PUREWELL BOILER IS INTENDED FOR USE AS A COMMERCIAL APPLIANCE AND IS  
NOT CERTIFIED FOR USE IN DOMESTIC APPLICATIONS.

**THIS BOILER IS FOR USE ON GROUP H NATURAL GAS (2<sup>ND</sup> FAMILY) I<sub>2H</sub> PLEASE  
ENSURE RELEVANT INFORMATION REQUIRED WITHIN DOCUMENT IS FOUND  
BEFORE FIRING BOILER.**

**COUNTRY OF DESTINATION : UNITED KINGDOM & REPUBLIC OF IRELAND**

THIS BOILER COMPLIES WITH ALL RELEVANT EUROPEAN DIRECTIVES.  
PRODUCT IDENTIFICATION No. 86CN70

**PUBLICATION NO. 500001170  
ISSUE 'Q'  
MARCH 2013**

## CONTENTS

	PAGE
<b>1.0 INTRODUCTION .....</b>	<b>1</b>
<b>2.0 SUPPLY AND DELIVERY .....</b>	<b>2</b>
<b>3.0 SIZE AND SPACE REQUIREMENTS .....</b>	<b>4</b>
<b>4.0 SITE LOCATION AND PREPARATION.....</b>	<b>6</b>
4.1 Site Location	
4.2 Gas Supply	
4.3 Flues	
4.4 Water Supply	
4.5 Condensate Connections	
4.6 Electrical Supply	
<b>5.0 BOILER ASSEMBLY .....</b>	<b>12</b>
5.1 Flue Pipe	
5.2 Water Connections	
5.3 Electrical Connections	
<b>6.0 PRE-COMMISSIONING .....</b>	<b>13</b>
6.1 Gas Supply	
6.2 Ventilation	
6.3 Pipework, Valves and Pump	
6.4 Flue	
6.5 Electrical	
<b>7.0 CHECKS PRIOR TO LIGHTING .....</b>	<b>14</b>
7.1 Boiler Gas System Leak Check	
7.2 Checks Prior to Lighting the Boiler	
7.3 Initial Lighting	
7.4 Combustion Checks	
7.5 User Instructions	
7.7 Burner Resistance Check	
<b>8.0 BOILER CONTROLS .....</b>	<b>21</b>
8.1 Controls Overview	
8.2 Controls Operation	
8.3 Functions	
8.4 LMU Fault Log	
<b>9.0 FAULT FINDING .....</b>	<b>37</b>
<b>10.0 SERVICING .....</b>	<b>37</b>
<b>11.0 REPLACEMENT OF FAILED COMPONENTS .....</b>	<b>39</b>
11.1 Igniter and Flame Probe Assembly	
11.2 Temperature Limiter	
11.3 Main Gas Valve	
11.4 Combustion Fan	
<b>12.0 RECOMMENDED SPARES.....</b>	<b>45</b>

**APPENDICES**

<b>APPENDIX A</b>	<b>GAS DATA</b> .....	<b>46</b>
<b>APPENDIX B</b>	<b>ELECTRICAL CONNECTIONS AND CONTROLS</b> .....	<b>47</b>
<b>APPENDIX C</b>	<b>FLUE DATA</b> .....	<b>50</b>
<b>APPENDIX D</b>	<b>VENTILATION</b> .....	<b>53</b>
<b>APPENDIX E</b>	<b>WATER DATA</b> .....	<b>54</b>

**PICTORIAL AND DIAGRAMMATICAL DATA**

<b>Figure 2.1</b>	Boiler Delivery .....	<b>2</b>
<b>Figure 2.2</b>	Boiler Package Dimensions .....	<b>3</b>
<b>Figure 2.3</b>	Header Kit Package Dimensions .....	<b>3</b>
<b>Figure 3.1</b>	Dimensions and Clearances .....	<b>4</b>
<b>Figure 3.2.1</b>	Manifold Dimensions for a 2 Boiler Installation .....	<b>4</b>
<b>Figure 3.2.2</b>	Manifold Dimensions for a 3 Boiler Installation .....	<b>5</b>
<b>Figure 3.2.3</b>	Manifold Dimensions for a 4 Boiler Installation .....	<b>5</b>
<b>Figure 4.2</b>	Gas Connection Point .....	<b>6</b>
<b>Figure 4.3</b>	Flue Connection Point.....	<b>8</b>
<b>Figure 4.4</b>	Water Connection Points.....	<b>9</b>
<b>Figure 4.5.1</b>	Boiler Condensate Connection.....	<b>10</b>
<b>Figure 4.5.2</b>	Boiler Condensate Connection.....	<b>10</b>
<b>Figure 4.6</b>	Electrical Connections.....	<b>11</b>
<b>Figure 5.2.1</b>	Rear Water Connections .....	<b>12</b>
<b>Figure 7.1.1</b>	Test Point Locations On Gas Valves .....	<b>14</b>
<b>Figure 7.1.2</b>	Gas System Leak Check.....	<b>14</b>
<b>Figure 7.2.1</b>	Location Gas Isolating Valve / Safety Temperature Limiter.....	<b>15</b>
<b>Figure 7.3.1</b>	Boiler Display With Low Inlet Gas Pressure Error.....	<b>16</b>
<b>Figure 7.3.2</b>	Low Gas Pressure Switch .....	<b>16</b>
<b>Figure 7.3.3</b>	Boiler Display With Low Inlet Gas Pressure Lock-out.....	<b>16</b>
<b>Figure 7.3.4</b>	Display For Boiler Ignition .....	<b>16</b>
<b>Figure 7.4.1</b>	Removal of Sample Point Plug.....	<b>18</b>
<b>Figure 7.4.2</b>	Combustion Analyser Probe setting.....	<b>18</b>
<b>Figure 7.4.5</b>	Burner pressure test point.....	<b>19</b>
<b>Figure 7.4.3</b>	Fan Assembly PV65he/PV85he High fire / Low Fire Adjustment .....	<b>20</b>
<b>Figure 7.4.4</b>	Fan Assembly PV105he/PV125he High Fire / Low Fire Adjustment .....	<b>20</b>
<b>Figure 8.1</b>	General Overview Of Boiler Fascia Panel.....	<b>21</b>
<b>Figure 8.1.2</b>	General Overview Of Boiler Controls .....	<b>22</b>
<b>Figure 8.2</b>	System Configuration Of Boiler Control (LMU) & System Peripherals .....	<b>22</b>
<b>Figure 8.2.12</b>	Info Display Parameters .....	<b>24</b>
<b>Figure 8.2.1.3</b>	Operation & Display Philosophy.....	<b>25</b>
<b>Figure 8.2.2</b>	Screen Legend .....	<b>26</b>
<b>Figure 8.2.3.1</b>	Default Display .....	<b>27</b>
<b>Figure 8.2.3.2</b>	Display Of Status Code .....	<b>27</b>
<b>Figure 8.2.4</b>	Display of Lockout Code .....	<b>28</b>
<b>Figure 8.2.5</b>	Heating Circuit Setpoint Temperature .....	<b>28</b>
<b>Figure 8.2.6</b>	Overview Of End User Parameters .....	<b>29</b>
<b>Figure 8.2.9</b>	Error Codes.....	<b>31</b>
<b>Figure 8.2.10</b>	Operating Mode Sysmbols .....	<b>32</b>
<b>Figure 8.3.11</b>	Operating Phases.....	<b>35</b>
<b>Figure 9.0</b>	Wiring Schematic .....	<b>36</b>
<b>Figure 11.1</b>	HIS & Flame Probe Sensing .....	<b>40</b>
<b>Figure 11.2</b>	Gas Valve Assembly Models PV65he/PV85he.....	<b>40</b>
<b>Figure 11.3</b>	Combustion System Assembly PV65he/PV85he .....	<b>41</b>
<b>Figure 11.4</b>	Combustion System Assembly PV105he/PV125he.....	<b>41</b>
<b>Figure 11.5</b>	Gas Train Assembly .....	<b>42</b>
<b>Figure 11.6</b>	Casing Assembly.....	<b>42</b>
<b>Figure 11.7</b>	Heat Exchanger Assembly PV65he/PV85he .....	<b>43</b>
<b>Figure 11.8</b>	Heat Exchanger Assembly PV105he/PV125he .....	<b>44</b>

<b>FIGURES</b>	<b>PAGE</b>
<b>Figure A1</b>	Gas Data ..... 46
<b>Figure B1.1</b>	Electrical Supply ..... 47
<b>Figure B1.2</b>	External Control Wiring for Multiple Boiler Installation ..... 48
<b>Figure B2.0</b>	In-line Fuse..... 49
<b>Figure C1</b>	Flue Data ..... 50
<b>Figure C1.1</b>	Flue Resistance..... 52
<b>Figure C1.2</b>	Open Flue (Natural Draught) B23 Flue System ..... 52
<b>Figure D1</b>	Mechanical Ventilation Flow Rates ..... 53
<b>Figure E1</b>	Water Data ..... 54
<b>Figure E1.1</b>	Cold Feed and Vent Pipe Sizes ..... 54
<b>Figure E1.2</b>	Typical Piping Layouts ..... 55
<b>Figure E1.3.1</b>	Schematic for Single Boiler System ..... 57
<b>Figure E1.3.2</b>	Schematic for Single Boiler, Primary Circuit System ..... 57
<b>Figure E1.3.3</b>	Schematic for Single Boiler (External 0~10V) Multi Circuit System..... 58
<b>Figure E1.3.4</b>	Schematic for Multiple Boiler (Cascade) Primary Circuit System ..... 58

## **1.0 INTRODUCTION**

**1.1** This boiler must be installed by a competent person. All installations **MUST** conform to the relevant Gas Safety and Building Regulations. Health & Safety requirements must also be taken into account when installing any equipment. Failure to comply with the above may lead to prosecution.

**1.2** These instructions are for Group H Natural Gas (2nd Family) only. The information relating to Natural Gas firing is to be found in Appendix 'A'. Boilers **MUST NOT** use gas other than that for which they were designed and made.

**1.3** The Purewell VariHeat *he* is a fully modulating, high efficiency, pre-mix type gas fired boiler. Manufactured from horizontal cast iron heat exchanger sections. The boiler is floor mounted and is intended for the heating of Commercial and Industrial premises. It may also be used to supply hot water for these premises via an indirect cylinder.

**1.3.1** Each boiler module has a dedicated Siemens LMU microprocessor based boiler management system, controlling and monitoring all safety and functional aspects of the boiler performance and it's integration with external system controls.

**1.3.2** The Purewell VariHeat *he* boiler is delivered to site fully assembled fitted with it's casing and controls. Care should be taken when manoeuvring the boiler into position to avoid damage.

**1.3.3** Each of the boiler models is designed for direct connection to a flue system. The flue system must be suitable for pressurised wet operation. The flue outlets from more than one unit may be connected to a single chimney. No draught diverter is fitted to the boiler nor is a fixed diverter required in the flue system. However a draught stabiliser is recommended for some installations—see Appendix 'C' (Page 44).

**1.3.4** The Purewell VariHeat *he* has a low water content and minimum flow rates **MUST** be maintained above the recommended levels shown in Appendix 'E' (Page 48)

**1.4** If the boiler is to be connected to an un-vented (pressurised) heating system, care must be taken to ensure all extra safety requirements are met and that the relevant interlocks will shut down the boiler(s) should a high or low pressure fault occur.

The pressurisation unit must also incorporate a low level water switch, which protects the water pumps, and will directly or indirectly shut down the boiler plant should a low water condition occur.

Consideration should also be given to the maximum working pressure of the boiler as given in Appendix 'E'. Consult Hamworthy Heating Technical Department for help or assistance if in doubt.

**1.5** The Purewell VariHeat *he* boiler is not suitable for direct connection to domestic hot water supplies or gravity fed heating systems.

**1.6** The Purewell VariHeat *he* boiler can be installed with either reverse return water flow layout or with single pipe header layout (non HHL supply). See Appendix E for typical schematic layout.

**1.7** It is good practice in all heating installations to use some form of water treatment to reduce formation of lime scale and black iron oxide sludge. The high efficiencies produced by the Purewell VariHeat *he* Boiler can easily be reduced by lime scale formation. If a pressurisation unit is used, it is prudent to include an hours run meter to give an indication of pump running time and hence raw water make-up. Any leaks should be attended to as soon as possible to avoid scale build up within the boiler's waterways.

**1.8** Each Purewell VariHeat *he* boiler is supplied with volt free contact outputs for Normal Run, Boiler lock-out from a General Fault, 0~10v analogue control input. Also provided are connections for BMS, Shunt Pump & Remote On/Off control as well as connections to a boiler lock circuit (causing the boiler to go to standby).

### **1.9 Options**

**1.9.1** Optional reverse return header kits are available in 2, 3 & 4 boiler configuration covering models 65he, 85he, 105he, 125he. These kits incorporate all necessary valves and interconnecting pipework. Refer to individual kit instructions for details.

#### **1.9.2 Controls peripherals**

The LMU boiler management system has the potential to accept the following control options:

##### **1.3.1.2 External sensor**

Allows direct weather compensation on an individual boiler. Not to be used for multiple boiler systems.

##### **1.3.1.3 Clip in module (LPB Bus)**

Allows communication with multiple boilers under the control of a Merley cascade control.

##### **1.3.1.4 Merley cascade control**

Allows cascade management of up to 12 boilers, and interface with a BMS system.

## **2.0 SUPPLY AND DELIVERY**

Your boiler is despatched to site as a pre-assembled and tested unit. Each boiler is delivered by a tail lift vehicle and lowered to ground level. It is the installers responsibility to convey the boiler to the plantroom.



**Figure 2.1 - Boiler Delivery**

The base of each boiler is specially designed to accept a standard pallet truck. This allows the boiler to be manoeuvred into position without any pallets to remove. Additionally the boiler is designed to pass through a standard doorway where access is restricted.

**NOTE:** The boiler is supplied with cardboard corner protection and shrink wrapped for protection during handling. However, when manoeuvring the boiler, care must be taken to avoid damage to the casing.

The boiler must be kept upright during handling. Care must be exercised to avoid toppling the boiler as this will result in damage.

The flue connection & condensate trap to the boiler are packaged separately to avoid damage. The flue components consist of an adaptor elbow, gasket and straight length of 150mm diameter flue pipe. The condensate trap is supplied loose beneath the front cover.



**Figure 2.2 - Boiler Packaged Dimensions**

Model	Depth	Width	Height	Weight
Purewell VariHeat he 65	1090mm	550mm	1310mm	205kg
Purewell VariHeat he 85				
Purewell VariHeat he 105				277kg
Purewell VariHeat he 125				

### **Delivery Verification**

When taking delivery please ensure that you have received the correct number of boilers and ancillary packages to fulfil your order. If any item is missing please contact our after sales service team. Please provide details of your order such as order number and contract number as well as a detailed description of the missing item.

---

### **Reverse Return Header Sets**

Where reverse return header sets are used these are packaged separately from the boilers.

Ancillary items such as isolation valves and flexible boiler connectors are packaged in a cardboard box on the same pallet. The whole is shrink wrapped for security and basic protection.

Model	Configuration	Length mm	Weight kg
65 - 85 he	2 boilers	1250	57
65 - 85 he	3 boilers	1784	95
65 - 85 he	4 boilers	2318	133
105 - 125 he	2 boilers	1250	112
105 - 125 he	3 boilers	1784	178
105 - 125 he	4 boilers	2318	300

**Figure 2.3 - Header Kit Packaged Dimensions**

### 3.0 SIZE AND SPACE REQUIREMENTS

3.1 The Purewell VariHeat he boiler range has been designed to utilise minimum floor space, therefore it is important the plantroom has sufficient ceiling height to allow for installation and connection to the flue system.

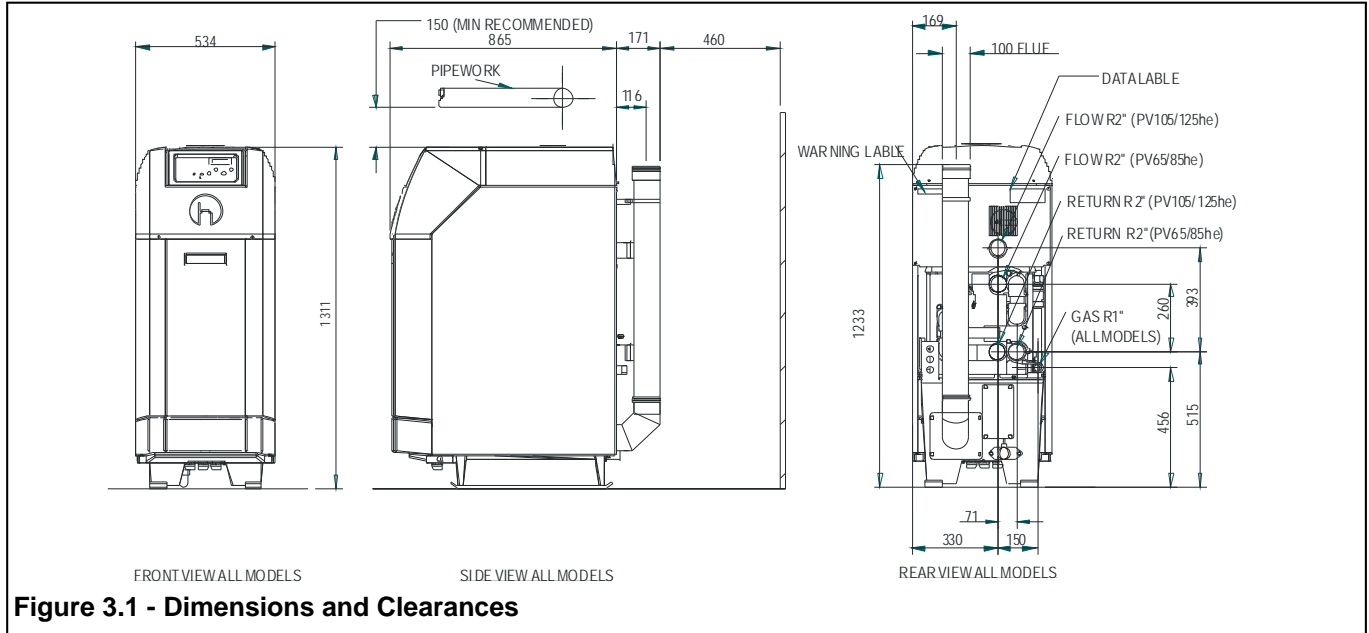
A minimum distance of 50mm must be maintained from easily flammable materials

Also important is allowance for sufficient access at front, sides and rear of boiler for flue and pipework connections.

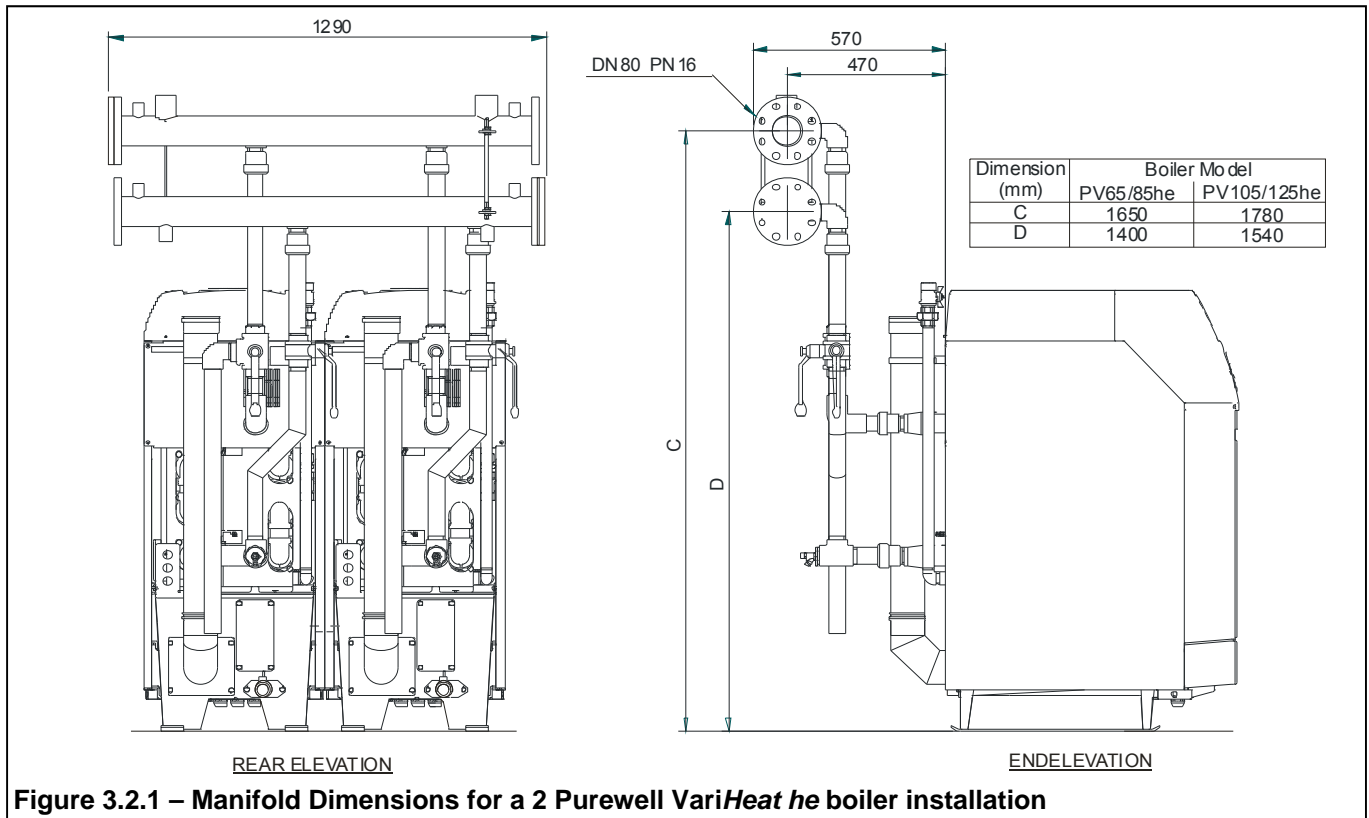
Ensure a minimum height of 150mm above the boiler for removal of the covers.

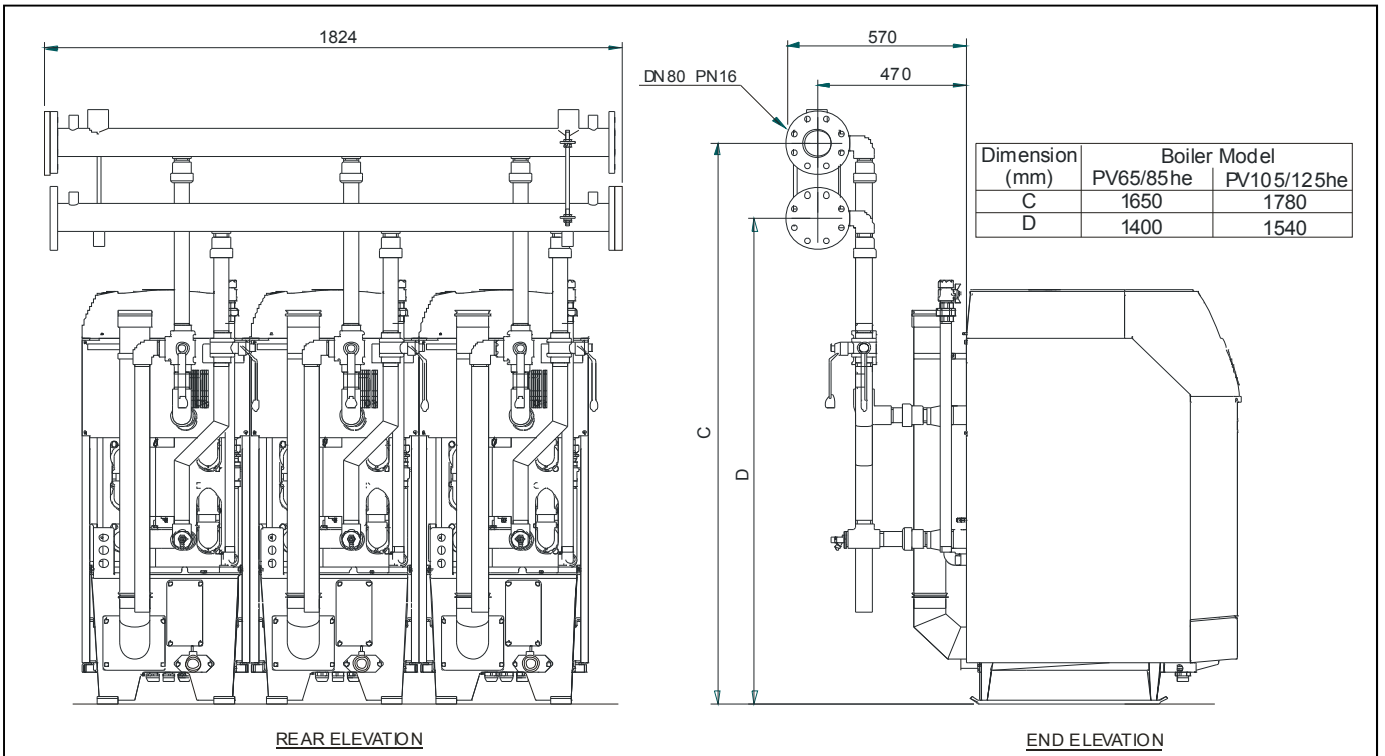
Do not run cabling through the top or display covers.

See Figure 3.1 below.

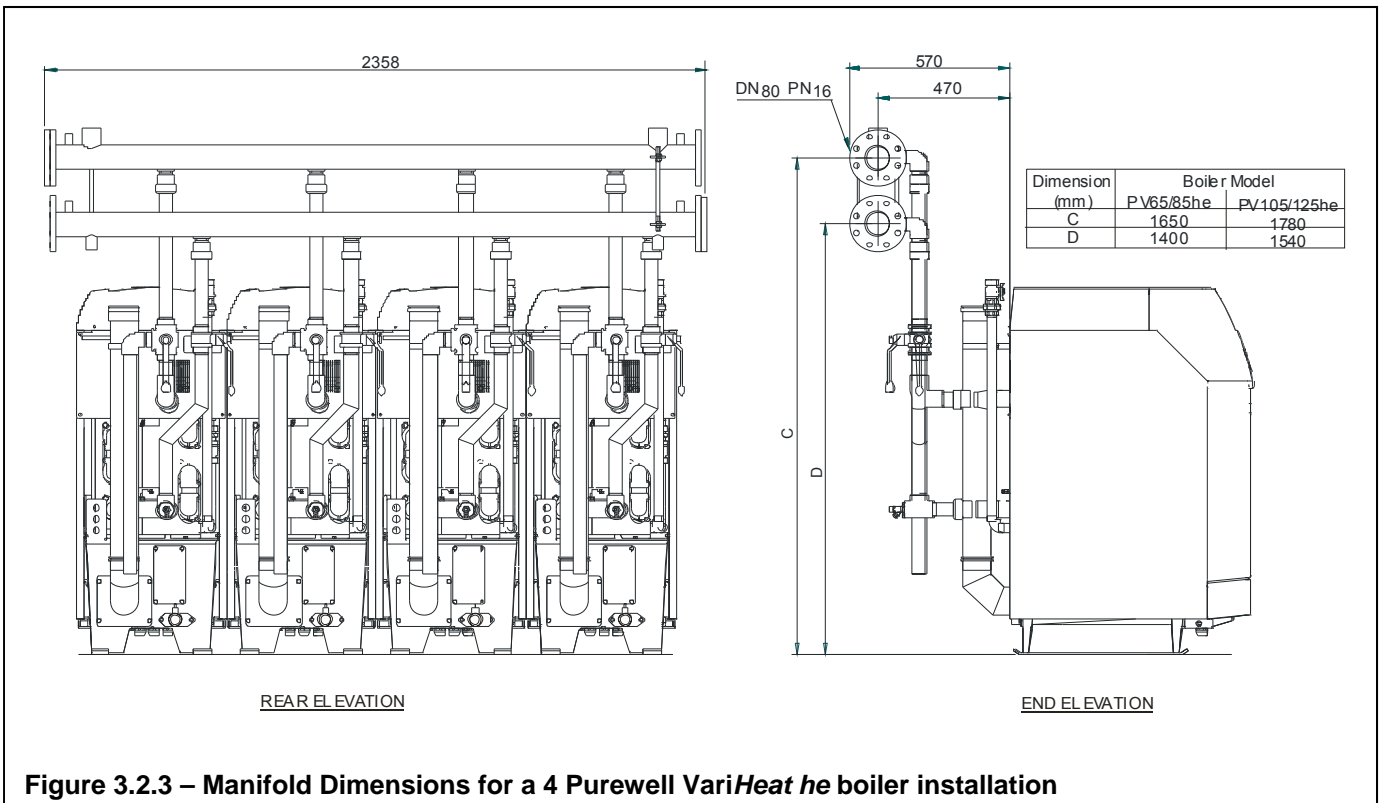


3.2 The Hamworthy Heating Ltd water manifold kit is designed to provide a compact solution for connecting the boilers to the gas supply and flow and return water connections. (Refer to the Manifold Kit Installer's Guide for specific details.)





**Figure 3.2.2 – Manifold Dimensions for a 3 Purewell VariHeat he boiler installation**



**Figure 3.2.3 – Manifold Dimensions for a 4 Purewell VariHeat he boiler installation**

Safety Valve: As each kit is provided with a 3 port isolating valve for use on the flow pipe, individual safety valves are not required on each module and a common valve can be fitted in the combined flow pipe. However, each boiler has a Rp1" connection (plugged) in the rear of the boiler heat exchanger assembly for use on applications where module isolating valves are not of the 3 port type..

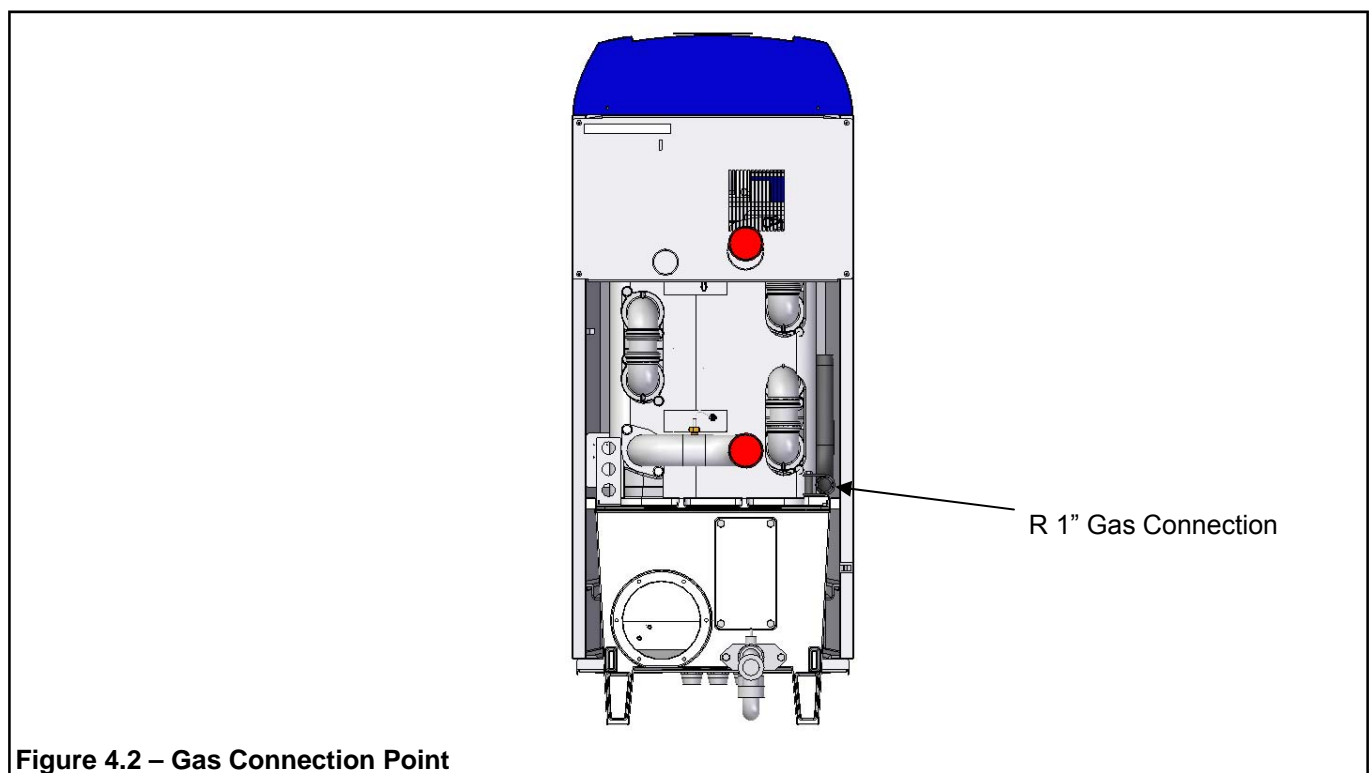
## **4.0 SITE LOCATION AND PREPARATION**

### **4.1 Site Location.**

- The floor or plinth for the boilers and water manifold kit must be both flat and level to ensure correct alignment of fittings and connections.
- The floor or plinth must be sufficiently strong to support the weight of both the boilers and manifold kit where used.
- The floor or plinth must be fireproof in accordance with BS 6644.
- The plantroom must have sufficient space for installation of boilers, manifold kits, pipework, pumps controls, flues ventilation, access and servicing and other items of plant.

### **4.2 Gas Supply.**

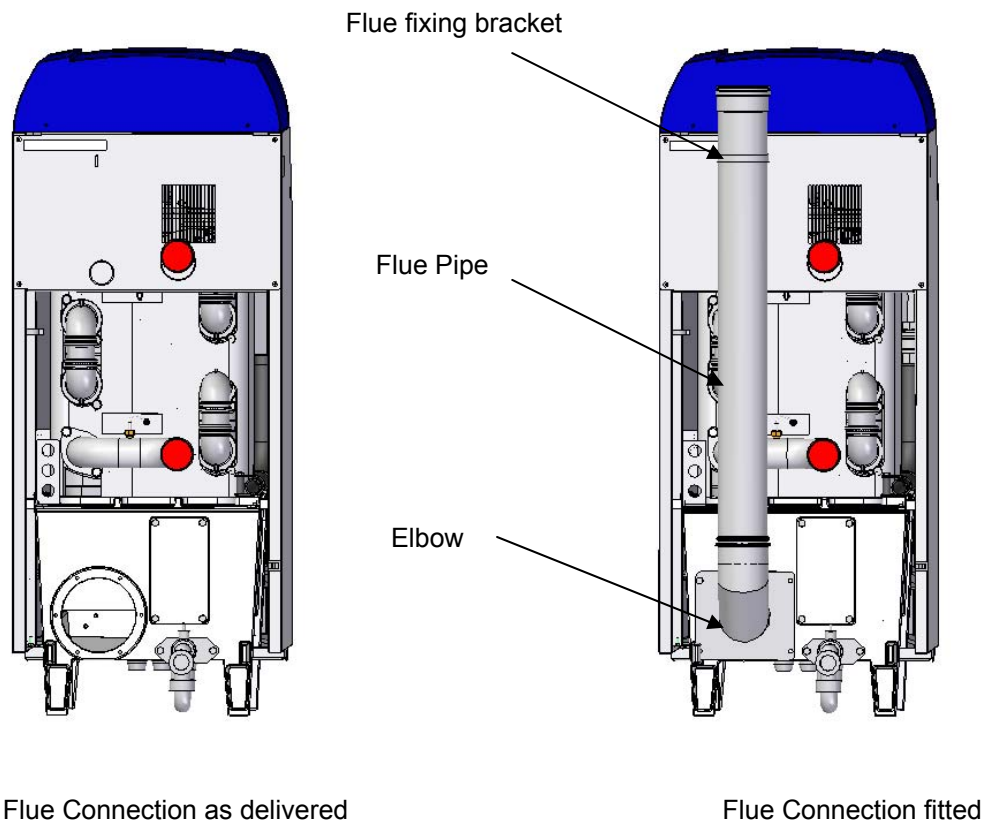
- Gas supply pipes must be in accordance with BS 6891 or IGE/UP/2
- Gas supply connection to the boiler must not be smaller than the connection on the boiler - R1”
- Gas installation must be soundness tested to BS 6891 or IGE/UP/1 & IGE/UP/1A.
- Gas installation must be purged to BS 6891 or IGE/UP/1 & IGE/UP/1A.
- Inlet gas pressure to boiler should be nominal 20mbar (minimum 17.5mbar) dynamic at the connection to the boiler.
- Boiler house gas isolation valve must be clearly identified and installed close to the entrance / exit.



### 4.3 Flues

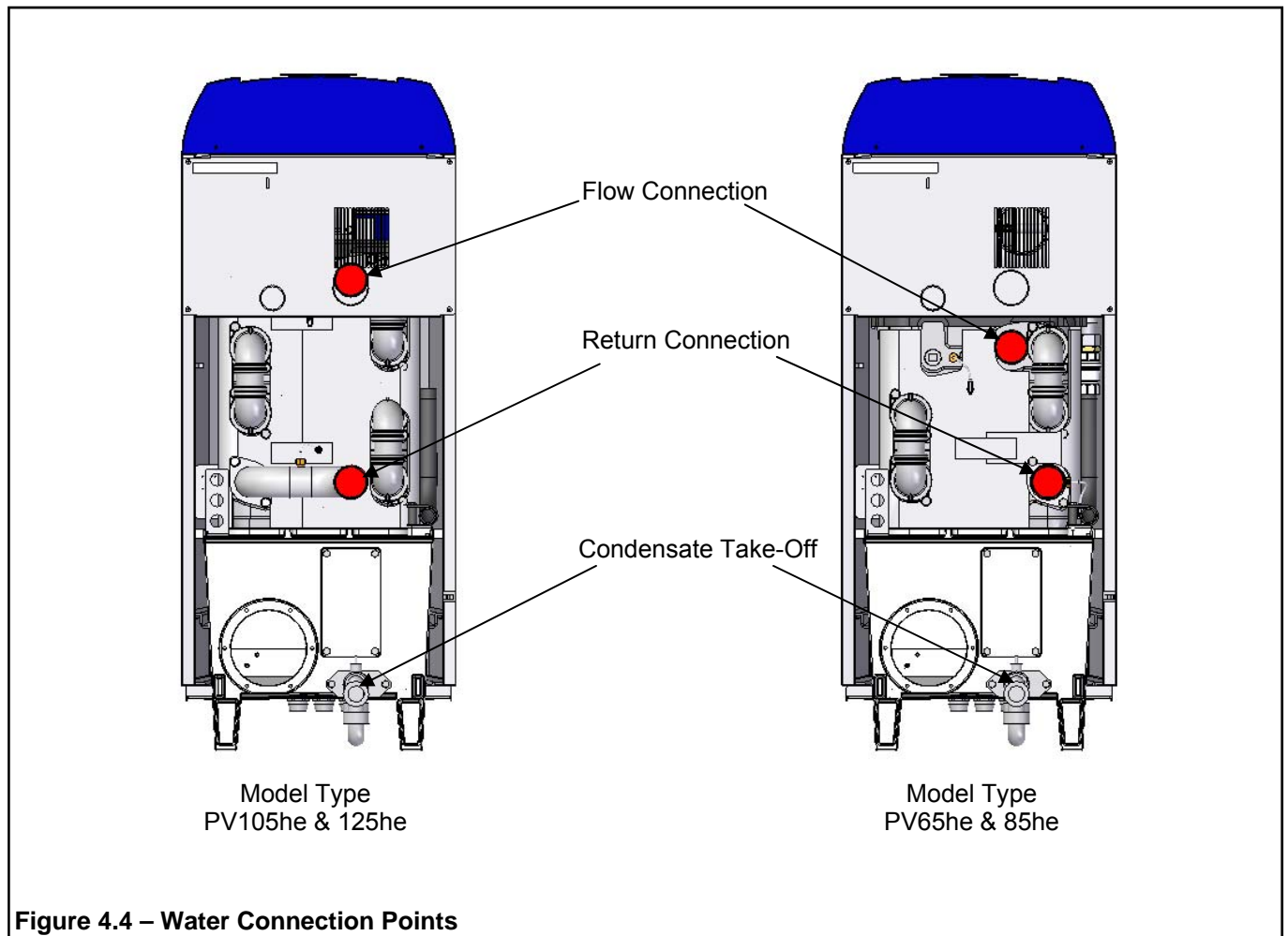
- Flue termination, routing and construction must comply with the requirements of the Clean Air Act 1993—Chimney Memorandum, BS 6644 BS 5440 and IGE/UP/10.
- Any flue must be self supporting and separable from the boiler for servicing requirements.
- The maximum number of modules firing into a common chimney is 9. For larger installations refer to HHL Technical.
- Due to the flue gas temperature, 60°C to 190°C , condensation will occur in the flue, flue materials must be non-corrosive and utilise fully sealing joints.
- Flue construction is recommended of a twin wall, insulated type to maintain buoyancy within the flue.
- Adequate facilities must be provided for draining the flue condensation.
- Horizontal flue runs must be kept as short as possible and be inclined at minimum 2° towards the termination.
- The flue system must be designed acknowledging that there may be a positive pressure generated by the boiler combustion fan. Refer to Appendix C.
- The flue system must be designed to limit the max. suction (cold) to 30Pa negative, measured at the connection to the boiler. If the suction is greater than 30Pa, refer to HHL Technical.
- This condition must then be checked hot and with all boilers firing, the max. pressure at the connection to the boiler is shown in the flue data table Appendix C. In the event that the flue system when hot does generate a suction, the max. suction is 100Pa.
- Any stabiliser fitted must be in or close to the vertical chimney.
- Fan dilution - the design must provide for the use of balancing and trim dampers, and their location and operation must be such that the constraints detailed above can be met. Care must be taken to ensure that the fan performance is matched to deliver the appropriate dilution, whilst ensuring that the excessive suction is not applied to the boilers. If in doubt, refer to HHL Technical.
- Fan assist - the use of fan assist must only be a last resort, as the boilers have sufficient fan performance to drive the system. If in doubt, refer to HHL Technical.
- Connecting flue systems may be smaller in internal diameter than the boiler connection and must be designed to deliver the necessary condition at the connection to the boiler. Refer to Hamworthy Heating Technical dept. for assistance.

Figure 4.3 – Flue Connection Point



#### 4.4 Water Supply

- Feed and Expansion tanks to comply with static height requirements of BS6880 & BS6644.
- Cold feed and open vent pipes to comply with requirements of BS 6644.
- Pressurised system to comply with BS 7074.
- It is recommended that the system pipework is flushed twice before water treatment.
- In hard water areas (>180mg CaCO<sub>3</sub>/litre) precautions such as water treatment are strongly recommended to prevent the build up of sludge and scale and also to control the system water pH to between 7.0 & 8.0..
- Leaks in the system pipework should be fixed to prevent dilution of water treatment.
- Maximum working water pressure is 7 bar.
- For minimum water pressure see Appendix 'E' - Water Data (Page 48)



## 4.5 Condensate Connections

- Provision must be made for removal of condensate from the boiler and flue system.
- Condense is mildly acidic, typically pH 3 - pH 5.
- Condense pipework must be non-corrosive and not copper. Hamworthy recommend 32mm dia. Plastic waste pipe.
- Condense may be discharged to a standard drain subject to National or Local regulations.

- Location of condensate pipework should prevent freezing within tundishes, traps and pipework.

- Do not allow blockage or damage to the condensate trap.

- The connection to the boiler condensate drain accepts a straight push-fit coupling for 32mm i.d. plastic waste pipe.

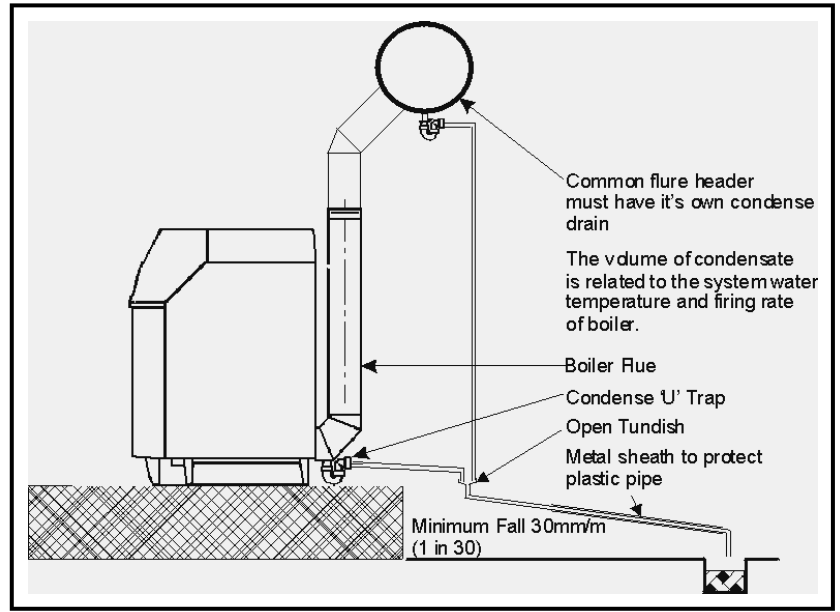


Figure 4.5.1 - Boiler Condensate Connection

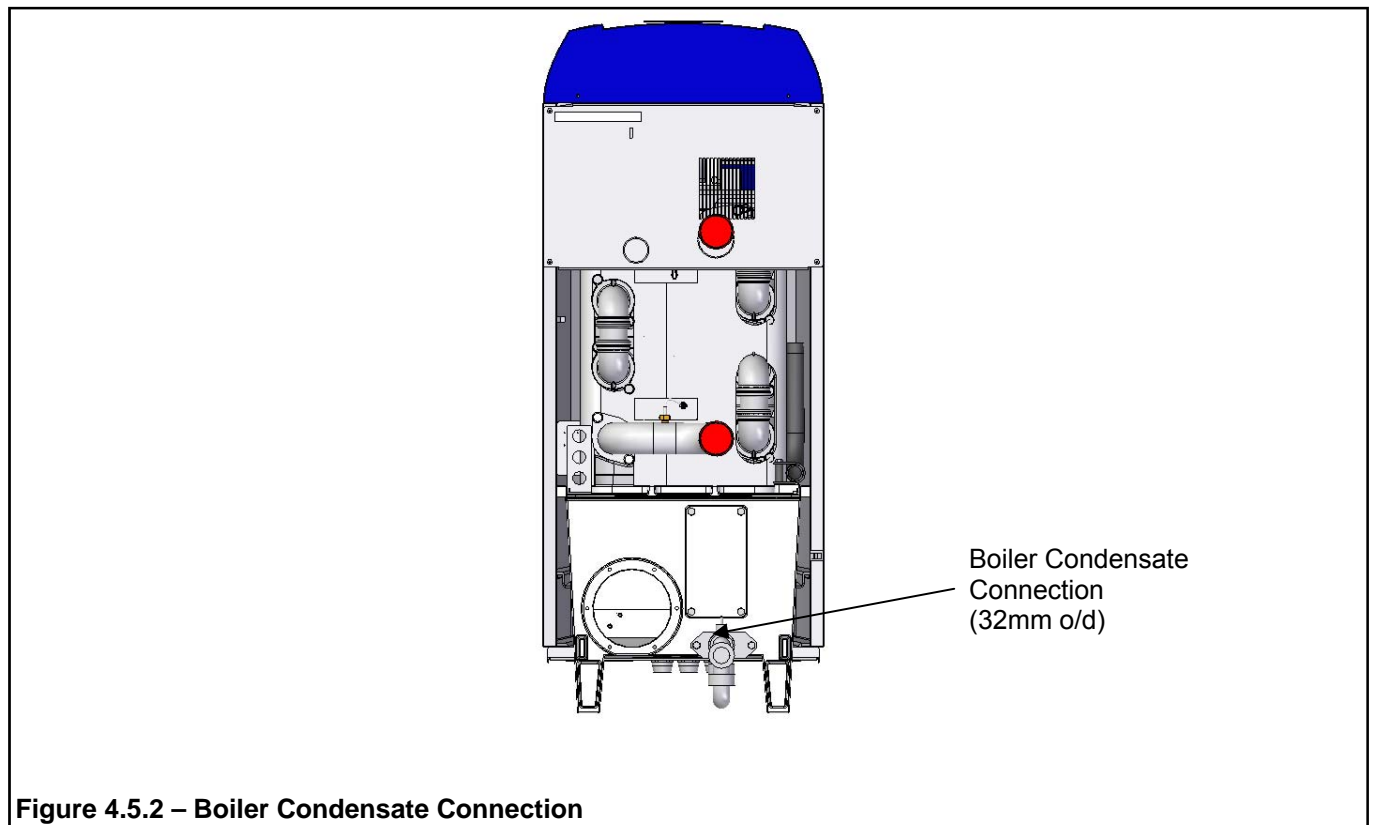


Figure 4.5.2 – Boiler Condensate Connection



#### 4.6 ELECTRICAL SUPPLY

**WARNING! THIS APPLIANCE MUST BE EARTHED IN ACCORDANCE WITH IEE REGULATIONS**

- Boiler electrical supplies must not be switched by a time clock.
- Boilers are suitable for 230Volt, 50Hz supply.
- External fuses should be rated for 10 amps
- Wiring must be completed in heat resistant cable size 1.0mm<sup>2</sup> csa.
- Each module should have individual means of isolation.
- Electrical isolators must facilitate complete electrical isolation.
- Electrical isolators must have contact separation of minimum 3mm in all poles.
- Electrical isolators must be installed in readily accessible locations.
- Electrical supplies to boiler modules should only serve the boiler.
- Where volt free contacts are used, these too must be individually isolatable.
- Time clock control should be via the boiler modules Remote On/Off circuit (30V DC). Any circuit connected to the Remote On/Off **MUST** be volt free

**ADDITIONAL INFORMATION REGARDING ELECTRICAL SUPPLIES IS GIVEN IN BS EN60335, Part 1.**

**NOTE: The appliance MUST be isolated from the electrical supply if electric arc welding is carried out on connecting pipework.**

**FOR DETAILED WIRING INSTRUCTIONS SEE SECTIONS 5.3, 9.0 & APPENDIX B**

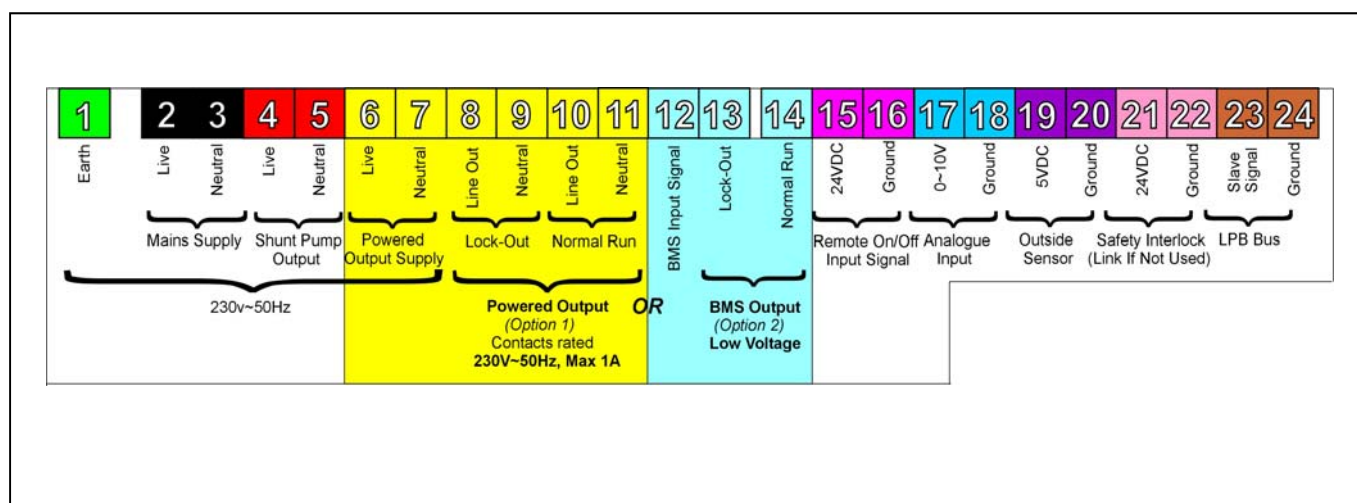


Figure 4.6 - Electrical Connections

## 5.0 BOILER ASSEMBLY

### General

Boilers are despatched to site as fully assembled units. The flue pipe, chimney, condensate drain connection and pipework manifold set (where applicable) are the only items that will need assembling on site.

During assembly it is important to take care to prevent damage to the boiler casing. **DO NOT STAND ON THE CASING PANELS.**

Boiler positioning must allow the minimum clearances detailed in Section 3.0 to facilitate access for flue and pipework connections as well as maintenance. Boilers can be positioned side by side, no clearance is necessary.

### 5.1 Flue Pipe

So as to avoid damage, the flue connecting pipe is supplied separately.

Fit the elbow to the base of the boiler and secure using the gasket and 4 - M8 nuts and washers. Moisten the lip seal and engage the flue pipe into the elbow. Secure the flue pipe to the boiler casing using the bracket supplied.

### 5.2 Water Connections:

Connecting pipework must be self-supporting to avoid stress on the boiler connections. Local unions are recommended in the pipework to facilitate future servicing requirements.

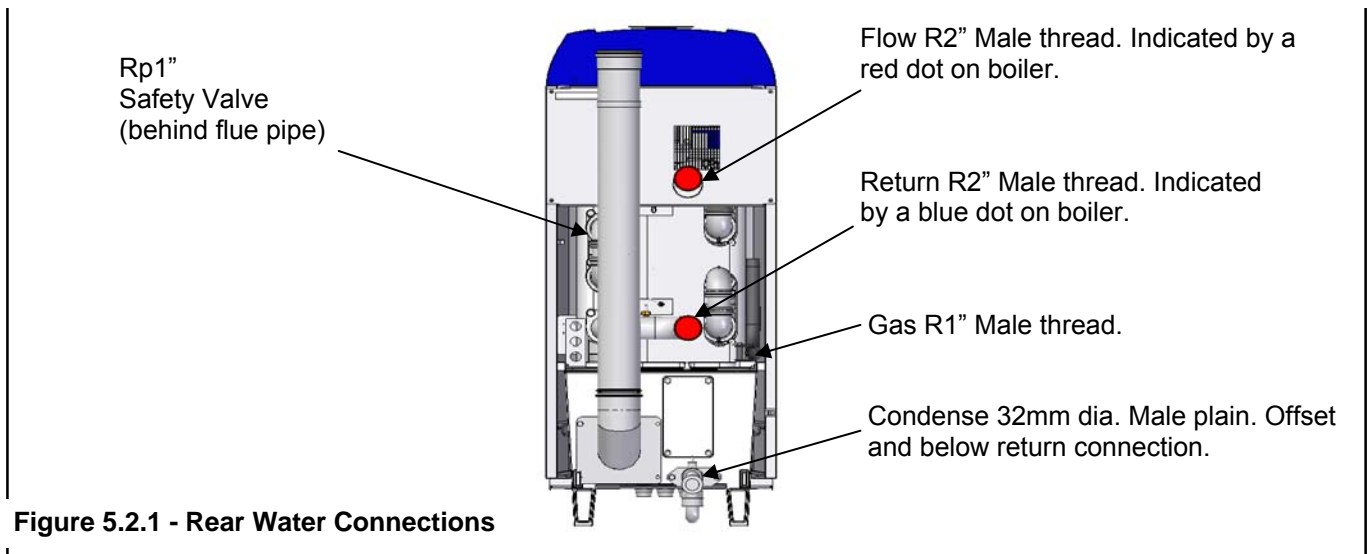


Figure 5.2.1 - Rear Water Connections

### Open Vented Systems

Boilers must not be capable of isolation from the vent pipe. Valves between boiler and vent pipe to be three way type such that when boiler is isolated from vent pipe it is open to atmosphere. Safety valves should either be mounted on the boiler by using the connection provided, or it should not be possible to isolate a safety valve common to more than one boiler from each boiler. BS6644 provides details.

### Sealed Systems

A boiler must not be capable of isolation from the individual or common safety valve. Valves between boiler and common safety valve to be three way type such that when boiler is isolated from safety valve it is open to atmosphere. The boiler is provided with a connection on the boiler for the safety valve .

Where using Hamworthy Heating Ltd pipework kits, assembly of these is detailed in the Instruction manual supplied with kit.

### 5.3 Electrical Connections:

The following electrical connections are provided on each module on a rail at the base of the front of the boiler.

- Supply: Live, Neutral and Earth. See Section 4.6 for details.
- Live and Neutral connections for Shunt pump or Primary Pump
- Boiler Overheat Fault Alarm Signal Output
- Common Fault Alarm Signal Output
- Boiler Normal Run Signal Output
- Remote On/Off
- 0-10v Analogue Control Signal Input
- External sensors
- Optional LPB Bus for use with Merley boiler sequence control

## **6.0 PRE-COMMISSIONING**

The following checks must be carried out before the boiler is commissioned.

### **6.1 Gas Supply.**

Ensure that gas installation pipework and meter have been soundness tested and purged to IGE/UP/1 or IGE/UP/1A as appropriate. Test and purge certificates should be available for viewing.

### **6.2 Ventilation**

Ensure that ventilation and air supply to plantroom is correct - refer to Appendix D (page 46). Air supply around the rear of appliance is unobstructed.

### **6.3 Pipework, Valves and Pump**

Ensure that;

- Pipework and valve arrangement is installed to Hamworthy Heating recommendations.
- Circulating system is full of water, vented and pressurised appropriately.
- Circulation pump is fitted, working and interlocked where required.
- Pipework connections to boiler are fitted correctly.
- All necessary isolation valves are open.
- Safety valve is correctly sized and located.
- Condense connections on boiler and flue are connected and piped to drain.
- Heat load is available.

### **6.4 Flue**

Ensure that;

- Flue system is correctly designed and installed to suit boilers.
- Flue passages to chimney are clear.
- Fill traps with water.

### **6.5 Electrical**

Ensure that;

- Electrical connections are correct and isolatable.
- External controls are operational.

**WARNING: IF THE FRONT COVER IS REMOVED WHILST THE BOILER IS OPERATIONAL, CARE MUST BE TAKEN WITH ELECTRICAL COMPONENTS AND ACCESS TO PRIMARY INSULATION.**

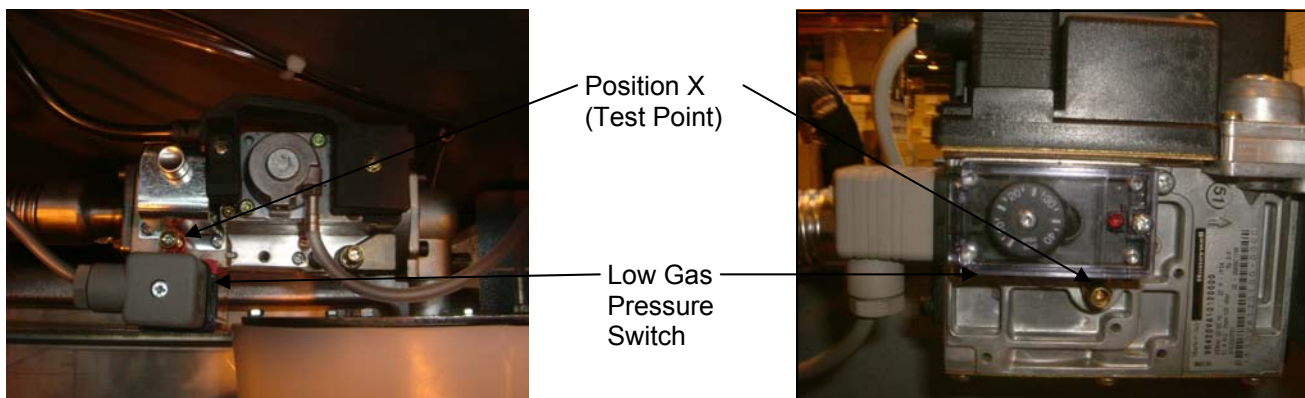
## 7.0 CHECKS PRIOR TO LIGHTING

**IMPORTANT: BEFORE PROCEEDING TO LIGHT THE BOILER, ENSURE THAT THE PRE-COMMISSIONING CHECKS HAVE BEEN CARRIED OUT AND THE RESULTS SATISFACTORY.**

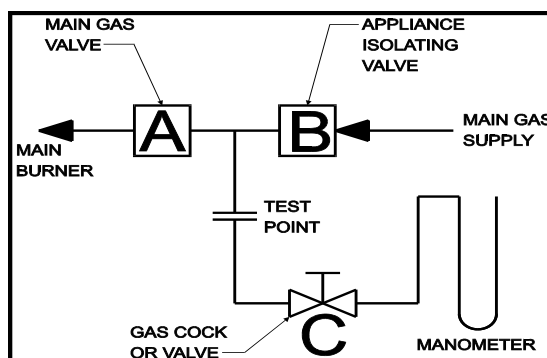
### 7.1 Boiler Gas System Leak Check

Ensure that the appliance manual gas service valve is in the OFF position. Although the boiler receives a gas leak check and gas train component integrity check prior to leaving the factory, transport and installation may have caused disturbance to unions.

A procedure guide is given below. Care must be taken not to allow leak detection fluid on or near any electrical parts or connections.



**Figure 7.1.1 - Test Point Locations On Gas Valves**



**Figure 7.1.2 - Gas System Leak Check Diagram**

**Note:** - Main gas supply pressure - G20 - 20mbar

#### To Check Valve B

- 1) Turn off the electrical power and gas to the appliance.
- 2) By unscrewing screw at Position X of Figure 7.1.1 remove the red gas pressure switch (L.H.S picture) or loosen the test point valve plug (R.H.S picture).
- 3) Connect the manometer to gas valve test point.
- 4) With A, B closed open C and monitor manometer over a 2 minute period, a rise indicates a leak on valve B.
- 5) Reinstall red gas pressure switch or shut valve plug in test point.

#### To Check Valve A

- 1) Repeat steps 1, 2, 3 & 5 above.
- 2) Open C.
- 3) Open B to produce the main gas supply pressure between A and B.
- 4) Close B
- 5) System may be considered sound if over a period of 2 minutes any drop in pressure is less than 0.5 mbar (0.2" wg.).

**NOTE:** Allow a manometer stabilisation period of approximately 1-minute before each 2 minute check period. Following soundness tests close valve B and remove manometer connections and tighten test points.

## 7.2 Checks Prior to lighting the boiler

**NOTE!** Refer to Appendix A for Natural Gas maximum gas inlet pressure for normal operation. **The following checks must be made prior to lighting the boiler.**

1) Ensure that the gas supply is connected but turned to the "off" position. Any unions or fittings are correctly tightened, test points are closed, and that the ignition and probe leads are connected correctly.

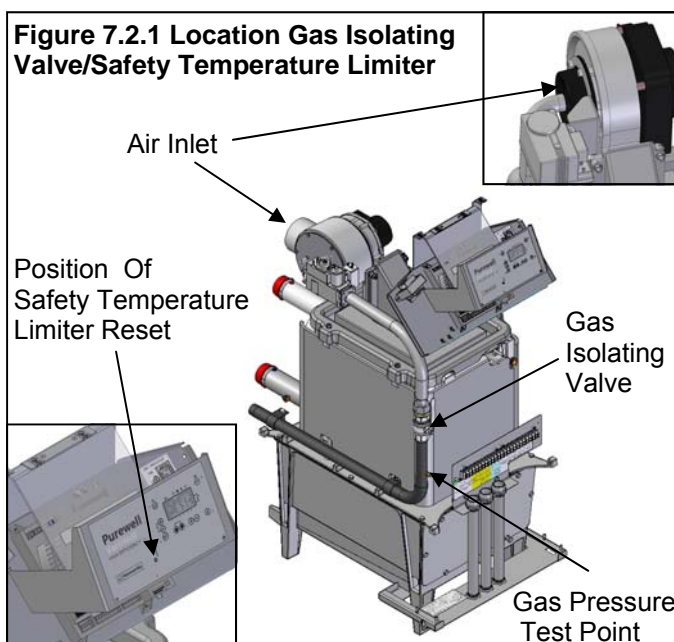
2) Ensure the electrical mains supply is correctly connected but the boiler isolator(s) are switched off. Remove the plastic covers by turning the fixing screws anti-clockwise a 1/4 of a turn. Check all wiring loom connections such as fan and gas valve, are correct and secure. Test the operation of the safety temperature limiter by removing the clip & bulb from the pocket in the front of the heat exchanger, and carefully apply a heat source to the bulb. The limit stat reset button should lift & protrude through the hole in the controls fascia. To reset, firmly press the button through the access hole in the controls fascia using a terminal screwdriver.

If satisfactory, refit the bulb in the pocket and secure with the clip. Ensure that all limiter bulbs /sensors are fully inserted into the pockets. The flow and return temperature sensors are located at the rear of the boiler in the flow and return pipes.

3) Check setting of both safety temperature limiter and control thermostat. The safety temperature limiter is set at 95°C. To remove the Safety Temperature limiter, found on the rear of the display fascia bracket. Remove the plastic display cover by turning the 1/4 turn screws anti-clockwise a 1/4 turn. by unscrewing it's fixing screws and unscrew the screws securing the thermostat from its mounting plate.

The control thermostat is factory set to a flow temperature of 85°C and must be re-set to suit the application, using button (2) on the fascia as detailed in **section 8.1.1- Controls Operation.**

5) Before ignition of the boiler it must be ensured that all parts of the appliance are clean and free from debris. Special attention should be paid to ensuring that the air inlet to the fan/venturi is clean and unobstructed.



6) Ensure the heating system circulation / shunt pump is operational and that the pipework is free of air.

7) To ensure correct ignition of the boiler it is recommended to check the resistance of the hot surface igniter. This should be checked cold, using a suitable ohmmeter, by disconnecting the igniter from the control panel cable and measuring the resistance across the pins of the 2 way connector. The reading should be approximately 70 to 110 ohms.

## 7.3 INITIAL LIGHTING

Only competent persons registered for working on non-domestic gas appliances should attempt the following operations. Before attempting to commission any boiler, ensure that personnel involved are aware of what action is about to be taken.

Record all readings for future reference on relevant commissioning sheet.

Allow system to warm up sufficiently to check operation of control thermostat.

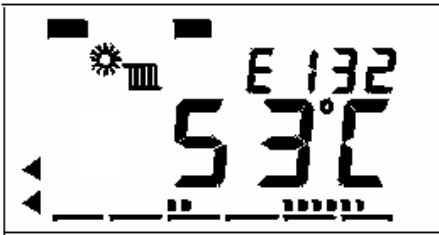
A combustion check must be taken when first commissioning the boiler. A sampling point is provided in the base of the boiler.

**NOTE!** Care should be exercised when the boiler is firing as the flue components can achieve temperatures, which could cause injury if touched.

### 7.3.1.1 Lighting the boiler

- 1) Refer to figure 8.1 for an overview of the control panel & what the push buttons do.
- 2) **Ensure that both gas & electrical supplies are isolated (off) from the boiler.**
- 3) **Disconnect the electrical plug to the gas valve.**

3) Turn on the gas valve (See fig 7.2.1) and boiler electrical supply. The boiler will display the screen of Fig 7.3.1.



**Note:** A gas supply pressure above 12.5 mbar will remove the Low Gas Pressure block on operation (indicated by the flashing 'E132') and in place of this code the present time is displayed.

The difference between a 'block' & 'lockout' is a block on operation occurs with a non safety critical fault condition. The boiler then automatically restarts on removal of the fault. A 'lockout' requires the boiler to be manually reset after a safety critical fault has been removed.

**Fig 7.3.1 - Boiler Display With Low Inlet Gas Pressure Error**

4) Check and adjust if necessary the low gas inlet pressure switch located on the side of the boiler gas valve.



5) To initiate the start-up sequence, press the 'Mode' button to start desired operation. The boiler will go through the start-up sequence provided the remote on/off contact is made and or the BMS system is in demand.

6) Check that the Hot Surface Ignitor begins to glow, by looking inside the boiler through the oval viewing window within the recess at the top right hand side of the boiler. (At this point, no gas is present in the boiler so no ignition occurs).

**Fig 7.3.2 - Low Gas Inlet Pressure Switch**



7) On failure to sense presence of a flame the boiler will display a flashing Error code of 133, before making a second ignition attempt. The boiler will then go to lockout. The boiler will display the screen of Fig 7.3.3.

8) Carefully reconnect the electrical plug to the gas valve and secure with the appropriate screw(s).

**Fig 7.3.3 - Boiler Display With Low Inlet Gas Pressure**

9) Turn on the gas and electrical supplies to the boiler & press the 'Reset' button to remove the 'lock-out' condition. The boiler will commence the ignition sequence. This time when the gas valve is energised, the gas will light.



- At the end of the 5 second ignition proving period, the hot surface igniter will be switched off and the fascia display will show a flame symbol to the left hand side of the temperature displayed. See Fig 7.3.4
- After a period of 15 seconds the fan will alter speed and the burner modulation will be set according to the heat load.
- If after the 10 second flame proving period the flame signal is below  $3\mu\text{A}$  the boiler will shut down and attempt one restart. If unsuccessful the boiler will display an error code of E128.

**Fig 7.3.4 - Display For Boiler Ignition**

10) Check the flame ionisation signal generated whilst the boiler is firing. This can be viewed directly from the display by accessing information level C1. The value is set to read dc  $\mu\text{A}$ . Refer to **section 8.2 - Controls Operation**.

## 7.3.2 Safety Checks


7.3.2.1 To check for correct operation of the controller, with the boiler running, carefully disconnect the flame probe lead from the flame probe.



The boiler will shutdown, attempt to relight once & then lock out causing **Error code E133** to appear on the display. Carefully reconnect the probe lead then press the reset (Enter) button to recommence the light-up sequence.

7.3.2.2 With the boiler firing, turn off the gas isolating valve and the boiler will shut down in 'Blocked' mode showing '**E132**' on the display. Wait at least 30 Seconds before opening the gas Isolating valve when the block will clear and the boiler will recommence the light-up sequence.

## 7.3.3 Flame Signal Assessment

The flame ionisation signal generated whilst the boiler is firing, can be viewed by using the following procedure.

7.3.3.1 Pressing the info button on the display screen : 

7.3.3.2 Press both up & down keys together for 5 seconds:   To bring you into the 'Extended Info Mode'

7.3.3.3 Using up & down arrow keys scroll through B, C or D modes & select 'Mode C'.


7.3.3.4 Using the   keys scroll through the options presented & select 'C1' to show the flame signal.

7.3.3.5 The value of the flame signal visible is set to read dc  $\mu$ A.

7.3.3.6 To return to the default fascia display press the mode button again.

## 7.3.4 - Adjusting the settings of the boiler

The desired Flow temperature setpoint can be set as follows:

7.3.4.1 Press the  button.

7.3.4.2 With the boiler showing one of the Status Screens, press the Up / Down key for the screen showing the actual flow temperature set point (factory set to a maximum flow temperature of 80°C).

7.3.4.3 By pressing the plus (+) & minus (-) keys will increase or decrease the setpoint in 1°C increments.

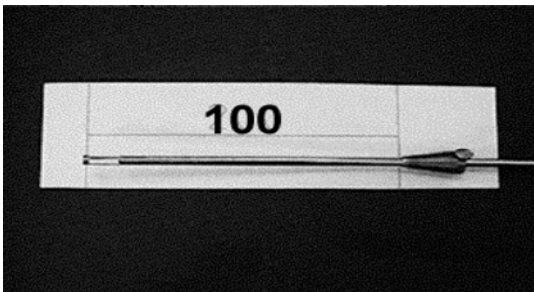
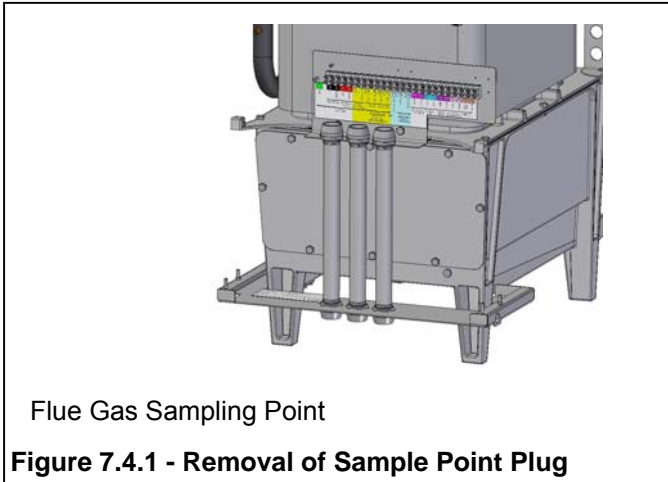
7.3.4.4 After changing the set-point to the desired value the 'Mode' key must be pressed to store this value and return to the boiler's default display.

**Should a set point higher than 80°C be required, please contact Hamworthy Heating, as programming for a higher maximum outlet temperature is restricted by a factory set access code.**

## 7.4 Combustion Checks

The boiler is factory preset, however, where checks need be undertaken during servicing to confirm correct performance within the installation.

- 1) Put boiler into service mode (**Section 8.2.8.1** Page 29) to enable the High & Low CO<sub>2</sub> figures to be measured.
- 2) Remove the sample point plug from the front of the base of the boiler.



- 3) Ensure that an insertion distance of 100mm is set on the combustion analyser probe.

**NOTE: THIS DISTANCE MUST BE SET TO ENSURE ACCURATE ANALYSIS OF THE FLUE GASES.**

- 4) Insert the probe into the base up to the set stop position .

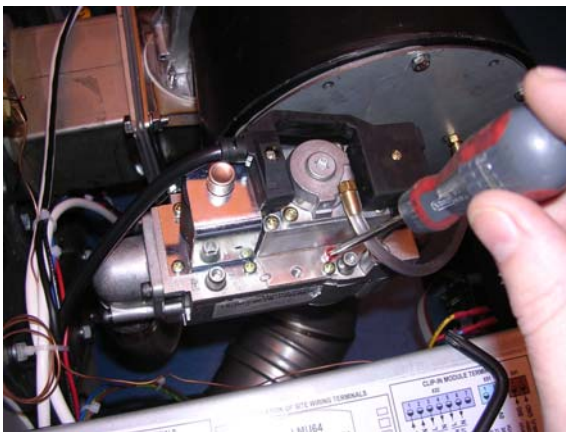
- 5) For Low Fire & High Fire Target CO<sub>2</sub> figures see information below.

- 6) CO = 0-50ppm: however figure should not exceed 200ppm under normal operating conditions.

- 7) If the combustion readings fall within the required range, the boiler is set and operating correctly.

- 8) Remove the combustion analyser probe & replace the sample point plug in the front of the base of the boiler.

- 9) If the combustion is outside of the ranges defined below, the factory sealed valves may be adjusted using the following procedure :



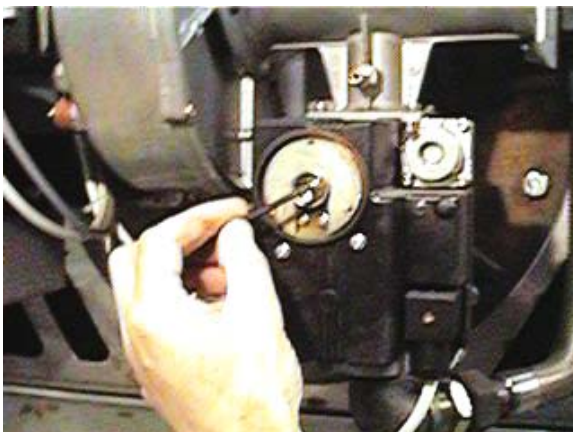
### 65he/85he

- High Fire Target - 65he **Nat Gas - 8.5% ±0.25% CO<sub>2</sub>**  
 85he **Nat Gas - 9.5% ±0.25% CO<sub>2</sub>**

If combustion level is outside of this range use the Cross Head Throttle Screw to adjust the mixture.

**THIS SETTING MUST BE CORRECT BEFORE CONTINUING**  
**To increase the CO<sub>2</sub> level, turn the adjustment anti-clockwise.**

### Figure 7.4.3.1 - Adjusting gas valve throttle



### 105he/125he

- High Fire Target - **Nat Gas 9.0% ±0.25% CO<sub>2</sub>**

If combustion level is outside of this range use the Cross Head Throttle Screw to adjust the mixture.

**THIS SETTING MUST BE CORRECT BEFORE CONTINUING**  
**To increase the CO<sub>2</sub> level, turn the adjustment anti-clockwise.**

### Figure 7.4.3.1 - Adjusting gas valve throttle





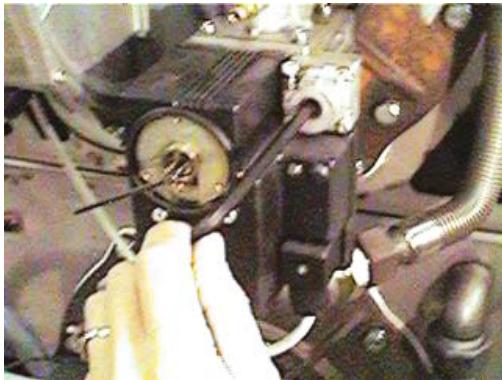
### 65he/85he

Low Fire Target - 65he **Nat Gas 8.5% ±0.25% CO<sub>2</sub>**  
 85he **Nat Gas 9.0% ±0.25% CO<sub>2</sub>**

If combustion readings are outside target range use Torx Bit to make adjustments

**To increase the CO<sub>2</sub> level, turn the adjustment clockwise.**

**Figure 7.4.4.1—Adjusting gas valve offset**



### 105he/125he

Low Fire Target - 105he **Nat Gas 8.5% ±0.25% CO<sub>2</sub>**  
 125he **Nat Gas 9.0% ±0.25% CO<sub>2</sub>**

If combustion readings are outside target range use Torx Bit to make adjustments

**To increase the CO<sub>2</sub> level, turn the adjustment clockwise.**

**Figure 7.4.4.1—Adjusting gas valve offset**

**7.5** Refer to **section 8.0 - Controls Operation**, to set the relevant boiler parameters and timings specific to the installation.

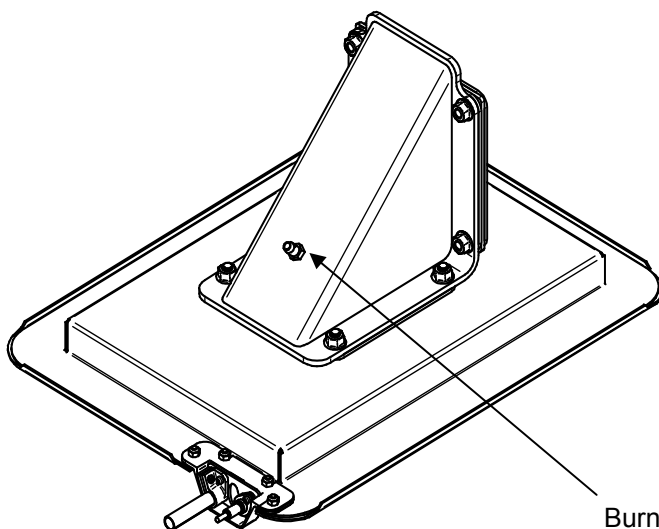
### 7.6 User's Instructions

The boiler owner or their representative should be made aware of the lighting and operating instructions. A practical demonstration should be given describing each functional step. This Installer's Guide and User's Instructions should then be handed over & kept in a safe place for easy reference.

### 7.7 Burner Resistance Check

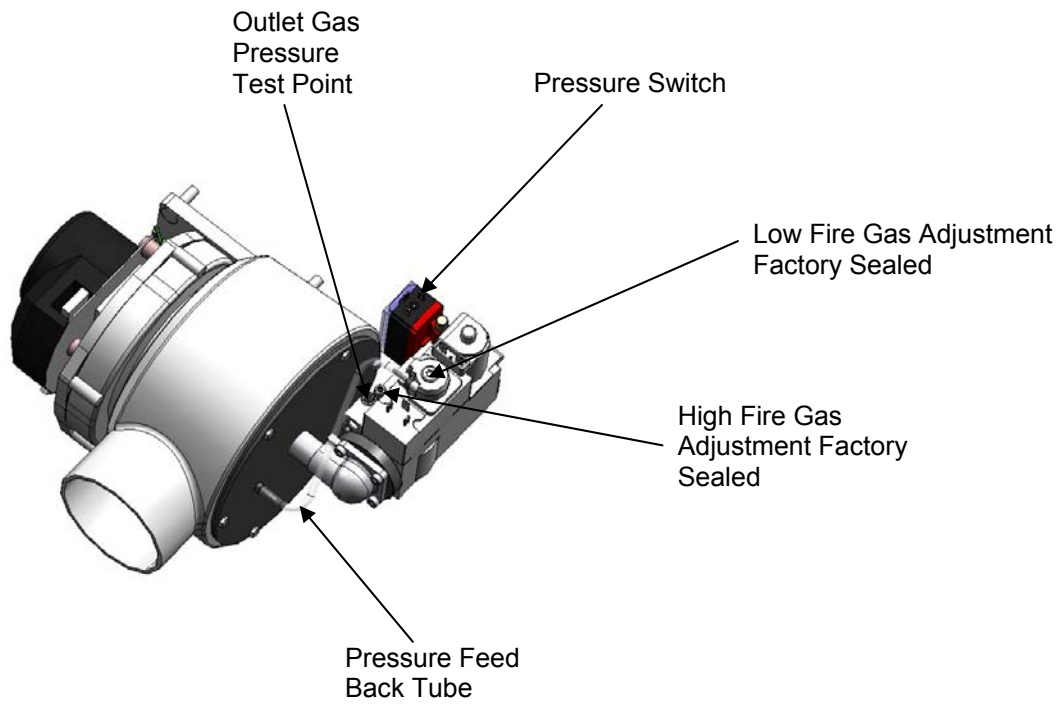
The burner pressure can be measured via a test point located on the gas inlet manifold as shown in figure 7.4.5.

Typical burner pressures measured for a new, clean burner are listed in the table below.

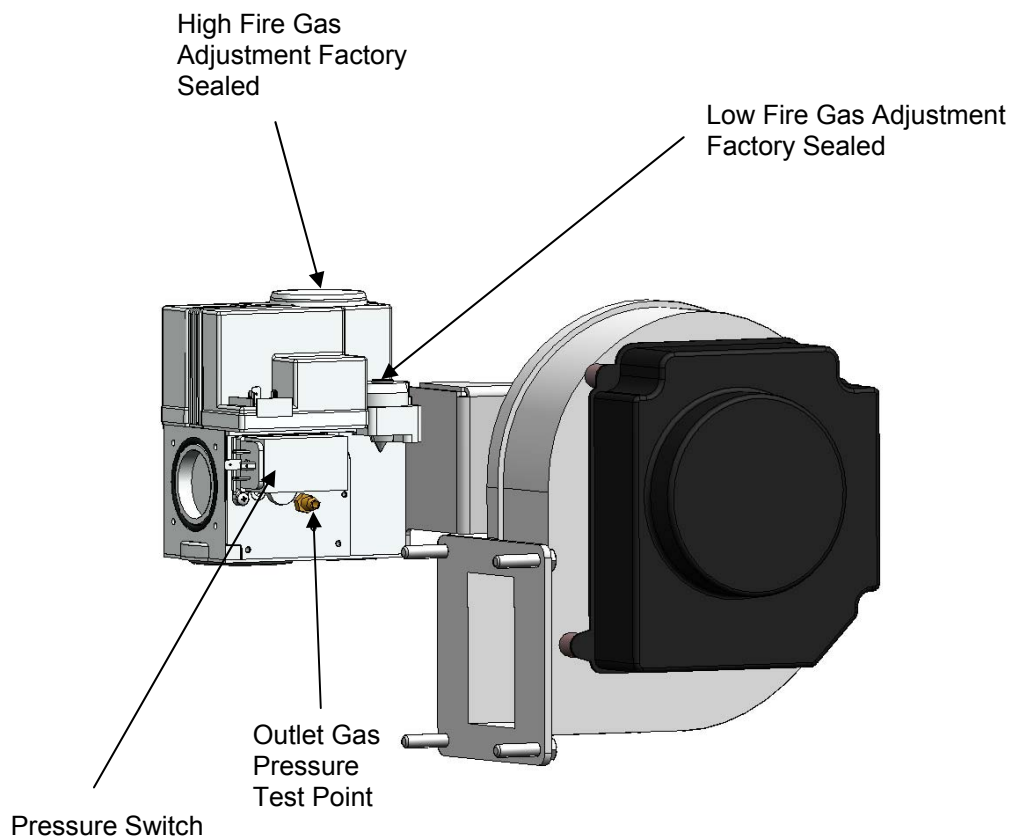


Model	Typical Burner Pressure - Clean burner
65he	1.7 - 2.2 mbar
85he	2.0 - 3.0 mbar
105he	4.0 - 4.5 mbar
125he	6.0 - 7.0 mbar

Figure 7.4.5 - Burner Pressure Test Point



**Figure 7.4.3 - Fan Assembly PV65he & PV85he**



**Figure 7.4.4 - Fan Assembly PV105he & PV125he**

## 8.0 BOILER CONTROLS

### 8.1 CONTROLS OVERVIEW

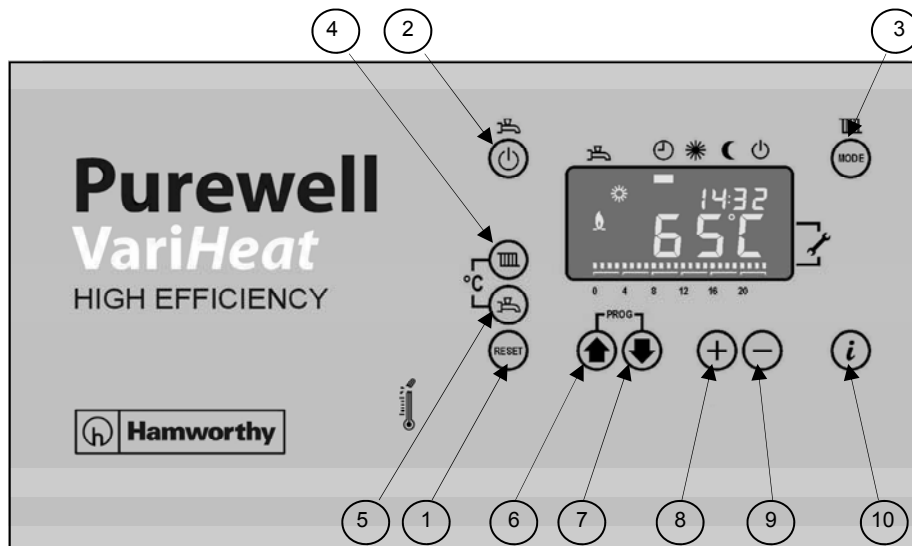
The Purewell VariHeat control system is a self contained, microprocessor based package (Siemens LMU64), controlling and monitoring all safety and functional aspects of the boiler performance and it's integration with external system controls.

Access to boiler performance information is via the HMI Facia display screen consisting of 2x16 character backlit LCD unit and 10 buttons for operation and setting of the boiler.

The system is compatible with BMS (or other) external controls via an enable or 0~10V DC input signal. The optional outside and mixed flow sensors are supplied by Hamworthy Heating Ltd to ensure safe and reliable operation.

The system provides as standard, 2 volt free contacts for external fault indication - Normal Run & General Fault. The Siemens LMU64 control system allows the connection of multiple boilers to an Merley cascade controller to enable control of up to 12 multiple boilers.

**Note:** To ensure safe and reliable operation, all wiring between sensors & boilers must be separated from mains voltage wiring.



Button	Function
1	Reset Lockouts
2	Not Used
3	Selection of Operating Mode
	Automatic (time control)
	Continuous ' Normal' temperature
	Continuous ' Reduced ' setback temperature
	Standby - boiler off.
4	Adjustment of boiler or room temperature
5	Not used
6, 7	Selection of operating parameter
8, 9	Adjustment of parameter value
10	Select Information display screens

**Figure 8.1 - General Overview of Panel Fascia**

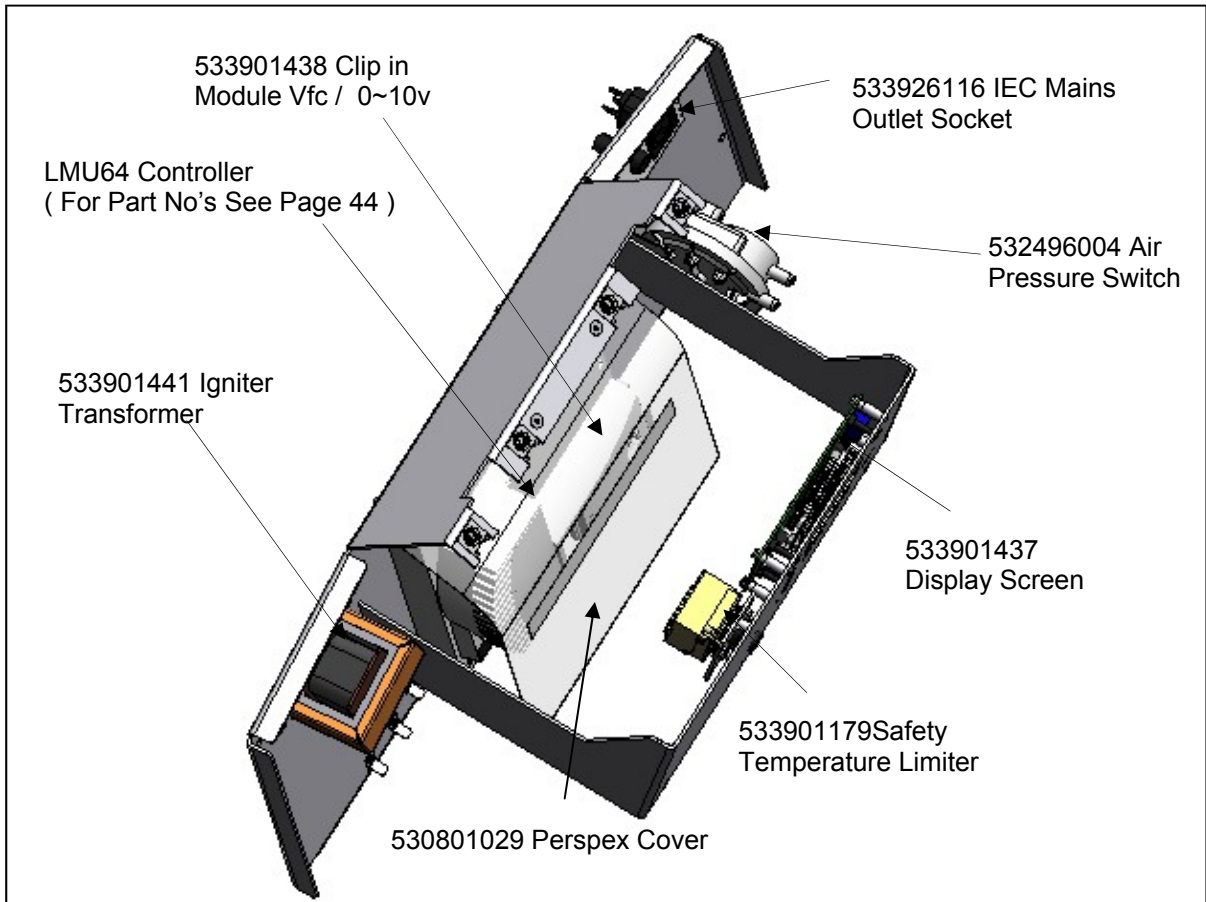


Figure 8.1.2 - General Overview of Controls

8.2 CONTROLS OPERATION

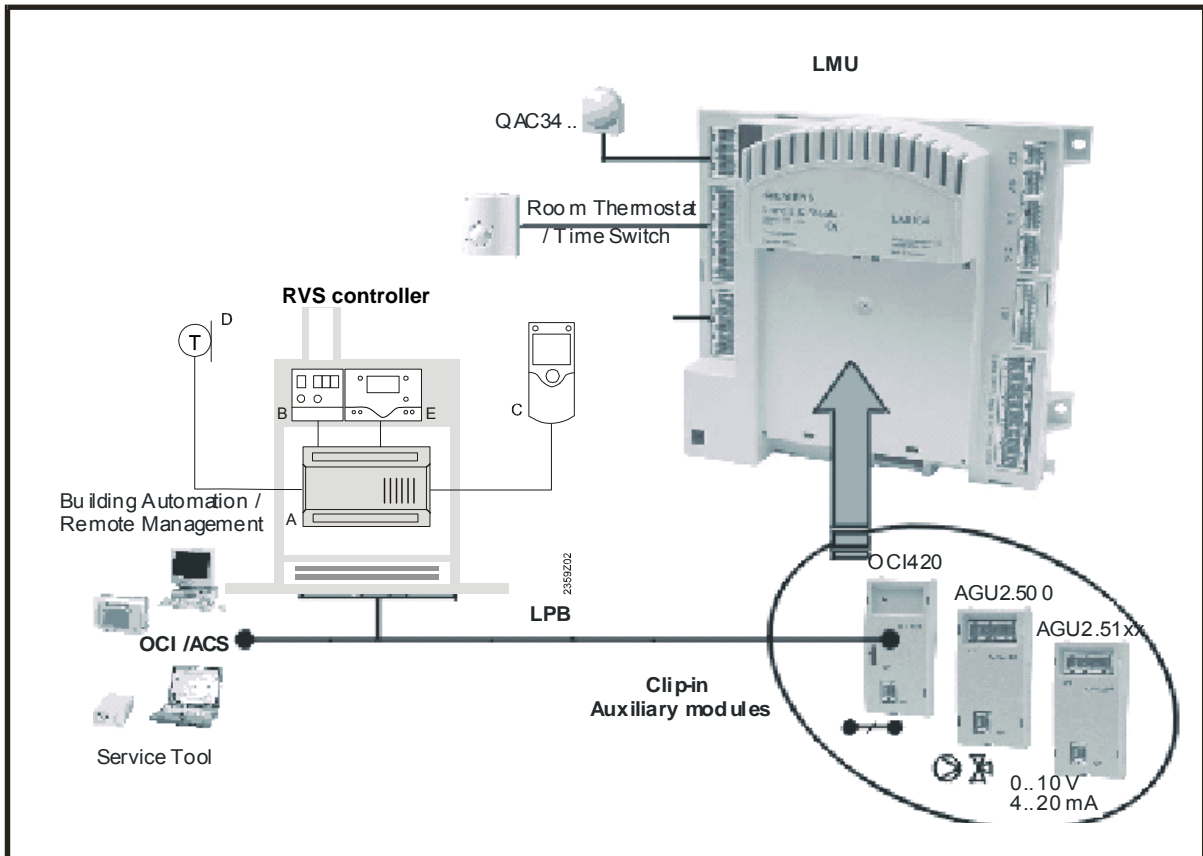









Figure 8.2 - System configuration of boiler control (LMU) & system peripherals

### 8.2.1 - Info button - refer to figure 8.1










A change on the information level can be made at any time by pressing the Info button.

















Additional pushes of the Info button will deliver the following data sequence provided by the information level.

	dhw temperature - <b>not used</b>
	Water Pressure
X.	Operating phase - refer to section 8.2.15
	Outside temperature
	Error code - refer to section 8.2.14
	Boiler temperature
 	Press one of these buttons to return to the default display

**Extended Info mode** - when on the information level, extended info mode levels b, c & d can be displayed.

Refer to Figure 8.2.2












 	Press both line selection buttons simultaneously for at least 3 seconds
 	Press one of these buttons to select the required display level
 	Press one of these buttons to select the required display value of the level
	Press the Info button to switch to the info display
 	Press one of these buttons to return to the default display

<i>Button</i>	<i>Operation</i>	<i>Function</i>
	Lockout reset	Resetting the LMU
	Enable dhw mode	dhw on/off - <b>not used</b>
	Enable heating circuit mode	selection of operating mode:
		Automatic operation
		Continuous 'Normal' Operation
		Continuous 'Reduced' Operation
		Standby
	Heating circuit temperature setpoint	Adjustment of boiler or room temperature setpoint.
	dhw temperature setpoint	Adjustment of dhw temperature setpoint - <b>not used</b>
 	Line selection (down / up)	Selection of operating parameter
 	Adjustment of settings	Adjustment of parameter settings
	Information	Select information display screens
 	Enable Maintenance mode	Press buttons simultaneously to select

**Figure 8.2.1.2 - Info display parameters**

The parameters of groups **b,C** and **d** can only be displayed

Display level	Name of LMU... variable	Description		
<b>General information (Enduser level)</b>				
<b>Temperatures (Service level) <sup>1)</sup></b>				
b 0	DiagnoseCode	LMU...-internal software diagnostic code		
b 1	TkRuec	Boiler return temperature		
b 2	Tbwlst2	DHW temperature sensor 2		<b>Not used</b>
b 3	Tabgas	Flue gas temperature		<b>Not used</b>
b 4	TiAussen	Outside temperature		
b 5	TaGem	Composite outside temperature		
b 6	TaGed	Attenuated outside temperature		
b 7	Tvlst	Flow temperature AGU2.500...		
b 8/ b9	Reserved			
<b>Process values (Service level) <sup>2)</sup></b>				
C 0	Reserved			
C 1	IonStrom	Ionization current		
C 2	Geb1_Drehz	Fan speed		
C 3	Geb1_PWM_AusAkt	Current fan control (PWM)		
C 4	RelModLevel	Relative output		
C 5	Pumpe_PWM	Pump setpoint (PWM)		<b>Not used</b>
C 6	ek0	Control differential		
C 7/ C8/ C9	Reserved			
<b>Setpoints (Service level) <sup>3)</sup></b>				
d 0	Reserved			
d 1	Tsoll	Setpoint of 2-position or modulating controller (PID)		
d 2	TkSoll	Current boiler temperature setpoint		
d 3	TsRaum	Room temperature setpoint		
d 4	TbwSoll	DHW temperature setpoint		<b>Not used</b>
d 5	PhzMax	Maximum degree of modulation in heating mode		
d 6	NhzMax	Maximum speed at maximum output in heating mode		
d 7/ d8/ d9	Reserved			

- Note <sup>1)</sup>
- 1 Press Info button 
  - 2 Press buttons for at least 3 seconds 
  - 3 Choose the relevant parameter with buttons 
- Note <sup>2)</sup>
- 1 Press Info button 
  - 2 Press buttons for at least 3 seconds 
  - 3 Press button 
  - 4 Choose the relevant parameter with buttons 
- Note <sup>3)</sup>
- 1 Press Info button 
  - 2 Press buttons for at least 3 seconds 
  - 3 Press button twice 
  - 4 Choose the relevant parameter with buttons 

Note after about 8 minutes, the display will automatically change to the default display.

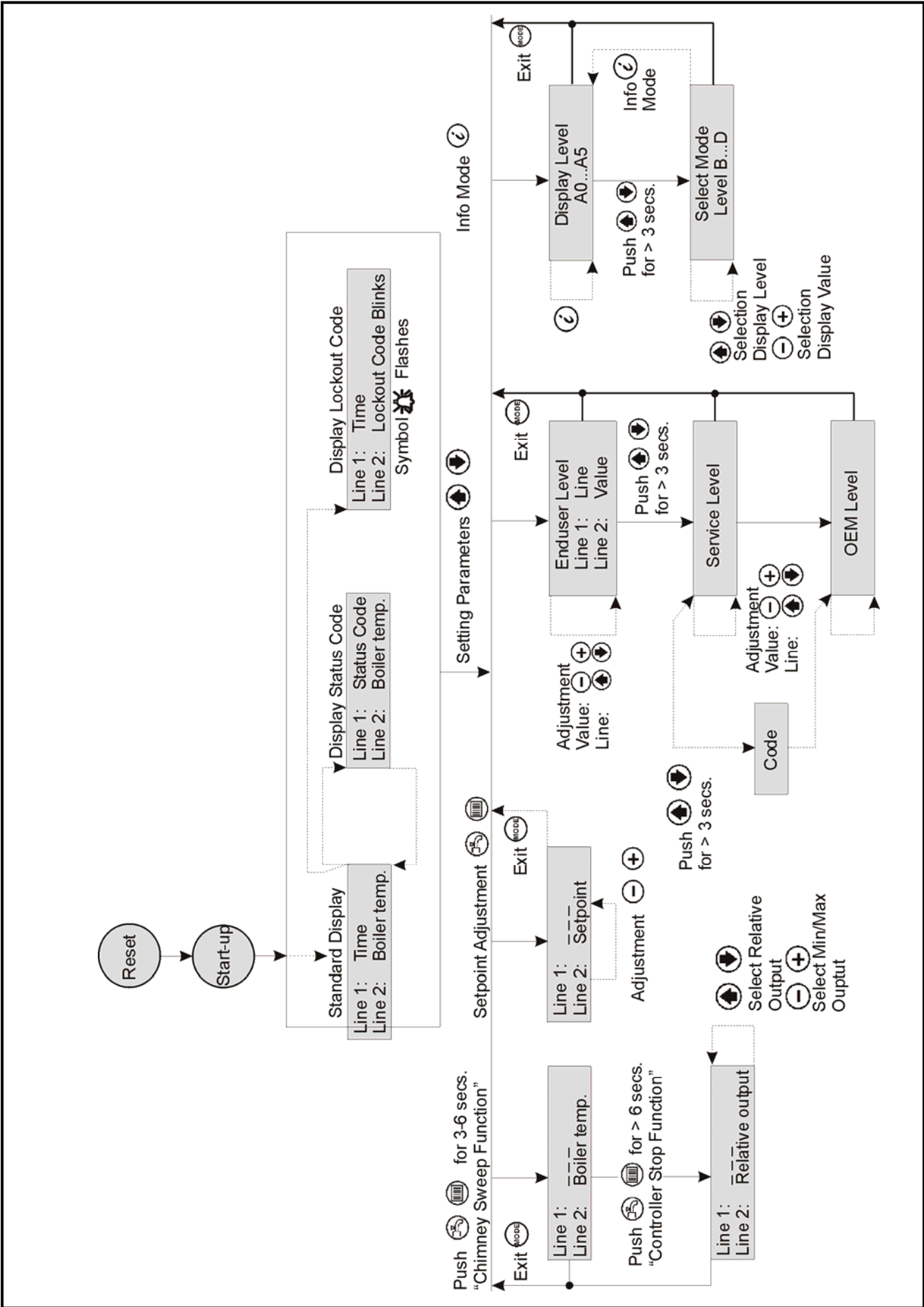


Figure 8.2.1.3 - Operation and display philosophy

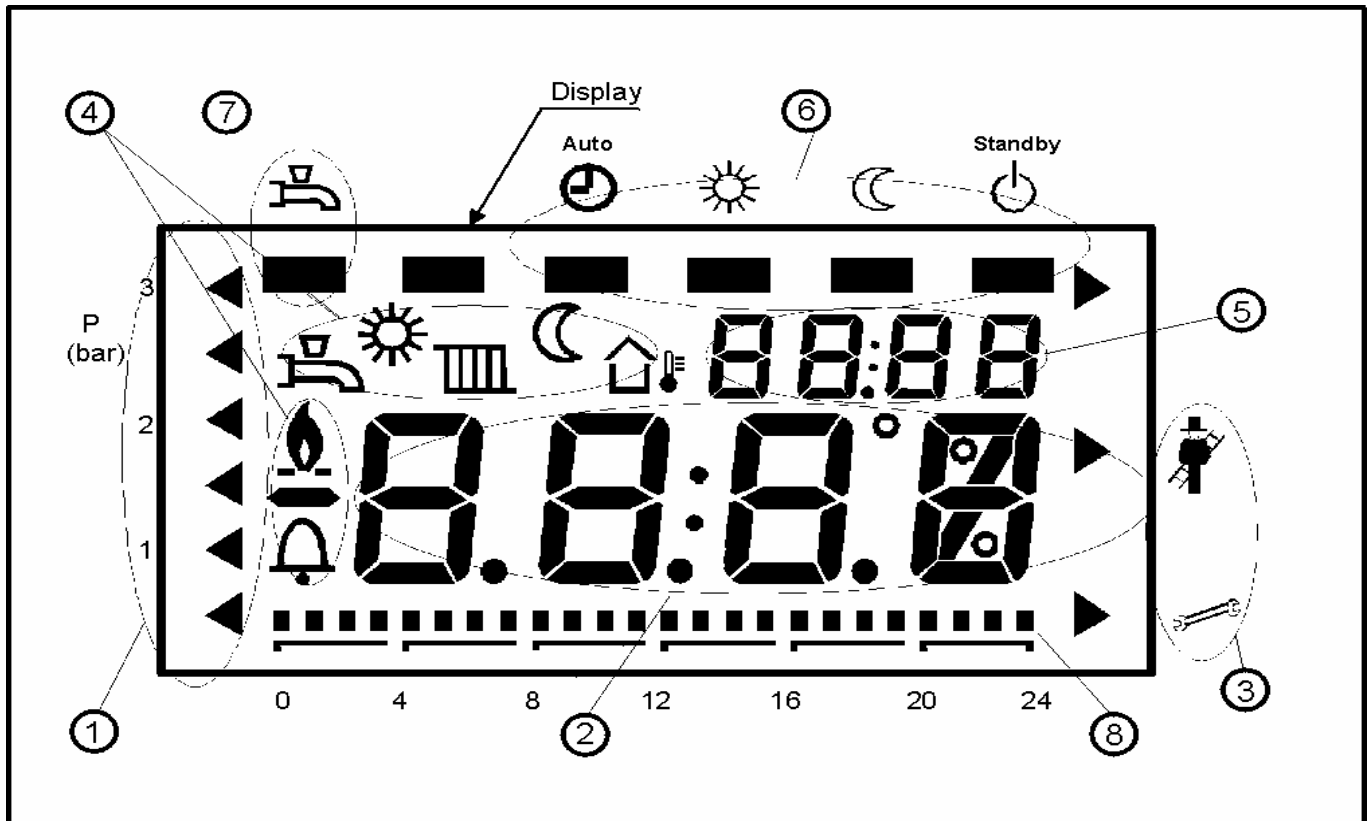













Figure 8.2.2 - Screen Legend

Character	Display	Function
①	Water pressure sensor signal	Display of water pressure (6 pointers) in increments of upto 10bar
②	Display (2) 4 x 7 large segments	Display of current value
③	Maintenance indicator flashing	Upper arrow - Chimney Sweep active Lower arrow - Controller Stop active
④	Display symbols	Meaning of symbols:  Display of dhw temperature or dhw heating active – <b>not used</b>  Display of boiler or room temp. set-point, or space heating active.  Display of outside temperature.  Operational level 'Normal'  Operational level 'Reduced'  Display of flame  Display of fault
⑤	Display (1) 4 x 7 small segments	Display of time of day, parameter settings or error code.
⑥	Operating mode of heating circuit	Operating mode is, or changes to:  Automatic  Continuous 'Normal' operation  Continuous 'Reduced' operation  Standby
⑦	Operating mode of dhw.	On or Off - <b>not used</b>
⑧	Time bar	Display of time program of heating circuit



### 8.2.3 - Default Display

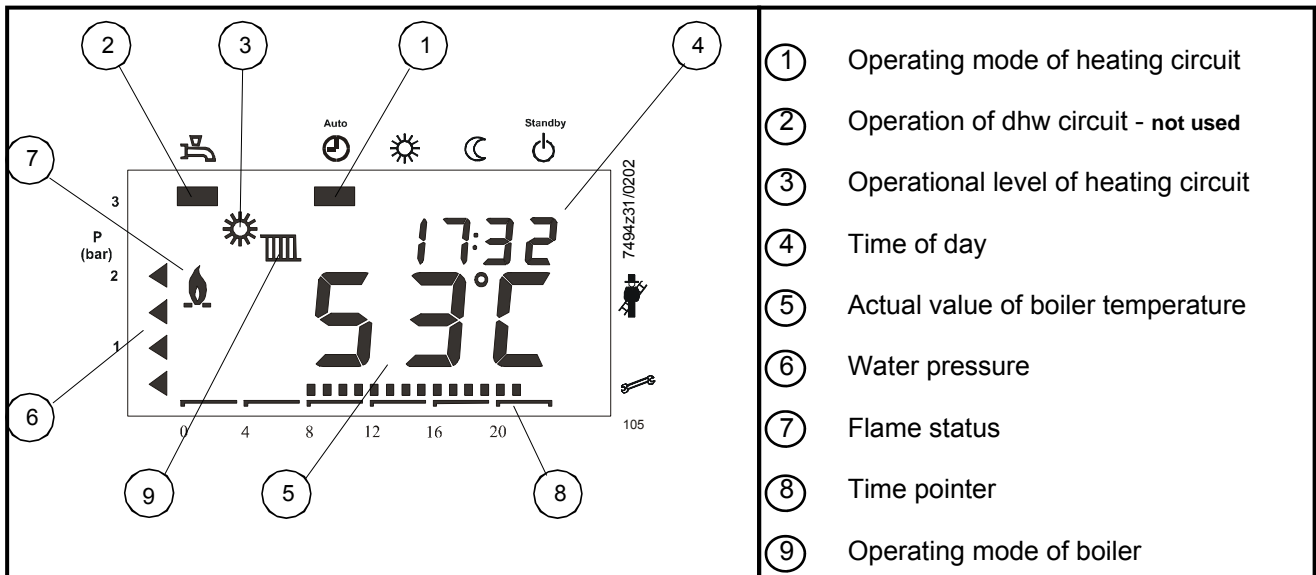


Figure 8.2.3.1 - Default display

If no button is pressed for about 8 minutes, the screen will automatically return to the default display.

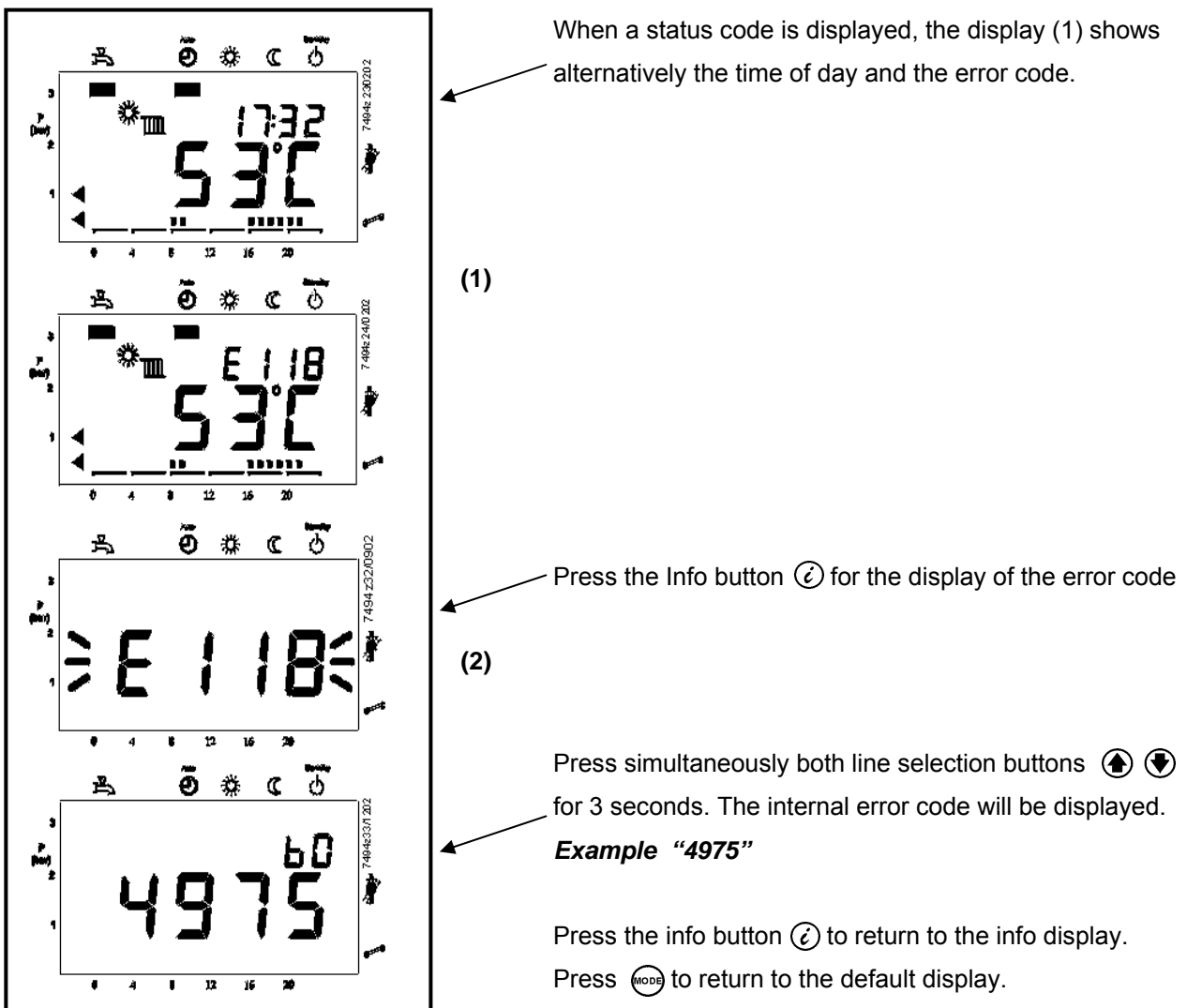


Figure 8.2.3.2 - Display of Status Code

## 8.2.4 - Lockout Display

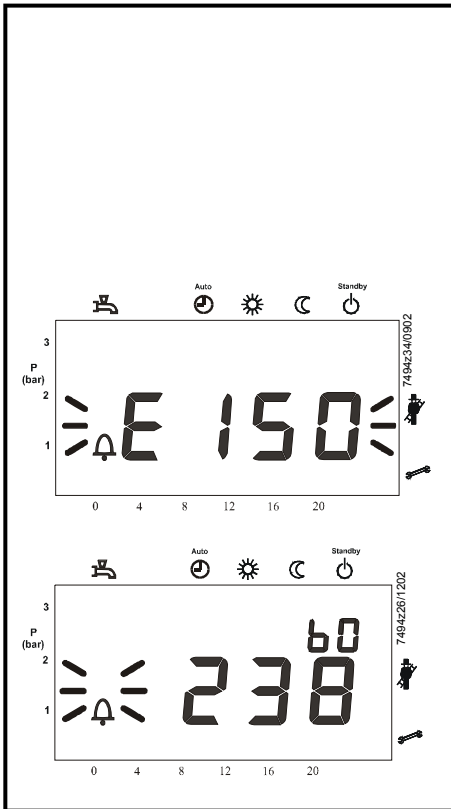


Figure 8.2.4 - Display of lockout code

In the case of a lockout code, the error code display flashes together with an 'Alarm symbol';

- (1) The LMU will go to lockout

**Example: "E150"**

- (2) Press the Info button (i) to switch to the error code

Press both line selection buttons (↑) (↓) simultaneously for 3 seconds. The internal error code will be displayed

**Example "238"**

Press the Info button (i) to switch to the Info display

Press (MODE) to return to the default display

**Note:** After rectification of the fault, press the reset button (RESET) (>0.6 seconds) to reset the LMU.

## 8.2.5 - Adjusting the heating circuit setpoint temperature

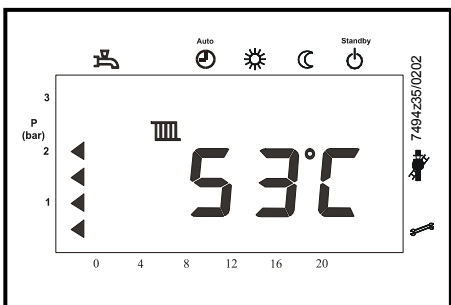


Figure 8.2.5 - Heating circuit setpoint temperature

Press the flow temperature button (🌡️) to adjust the heating circuit setpoint

- (1) Press (−) (+) to adjust the required setpoint

Press (MODE) to return to the default value









Changes will be stored.

The room temperature setpoint or boiler temperature setpoint will be changed depending on the plant's configuration ( with or without outside sensor).

If no button is pressed for about 8 minutes, the screen will automatically return to the default display. Changes will be stored.

## 8.2.6 - Parameter settings for the Enduser

The boiler is supplied with default settings. These must be modified to suit individual Enduser needs.

 	Press one of the line selection buttons. This will take you to programming level <<Enduser>>
 	Press the line selection button to choose the relevant line. The display shows <<Pxxx>>
 	Adjust the required value with one of these buttons. The adjustment is stored as soon as you change to some other line (to alter individual items, a change of parameter is required). The Enduser Parameter list details all possible settings.
	Press button to leave the programming level. Changes will not be stored
	Press the Info button to leave the programming level. Changes will be stored

**Note:** If no button is pressed for about 8 minutes, the screen will automatically return to the default display. Changes will not be stored. When switching to another level, changes will be stored.

**Figure 8.2.6 - Overview of Enduser parameters**

Line	Function	Range	Unit	Resolution	Default value
<i>Time of day</i>					
1	Time of day	0...23:59	h / min	1 min	---
<i>Setpoints</i>					
5	Reduced room temperature setpoint «TrSollRed» or (reduced boiler temperature setpoint «TvSollRed») (When using an additional room unit, line 5 will be hidden)	TRF...TRN	°C	0.5	16.0
<i>Time program HK1 (heating circuit 1)</i>					
11	Time program HC1 switch-on time 1 <sup>st</sup> period	00:00...24:00	hh:mm	10 min	06:00
12	Time program HC1 switch-off time 1 <sup>st</sup> period	00:00...24:00	hh:mm	10 min	22:00
13	Time program HC1 switch-on time 2 <sup>nd</sup> period	00:00...24:00	hh:mm	10 min	24:00
14	Time program HC1 switch-off time 2 <sup>nd</sup> period	00:00...24:00	hh:mm	10 min	24:00
15	Time program HC1 switch-on time 3 <sup>rd</sup> period	00:00...24:00	hh:mm	10 min	24:00
16	Time program HC1 switch-off time 3 <sup>rd</sup> period	00:00...24:00	hh:mm	10 min	24:00

## 8.2.7 - Start-up / Initialisation

On startup after power-On, or after a lockout reset, the setpoints will be initialized.

These setpoints apply until a first adjustment is made (e.g. via the screen display or PC parameterization):

After a readjustment, these values will be overwritten with the new value and permanently stored in the LMU.

When a new startup is made, or after power-On, the previous settings will be stored in the LMU.

Also, the software version number of the operator module and that of the connected type of LMU... will be delivered.

## 8.2.8 - FUNCTIONS

### 8.2.8.1 - Chimney Sweep function


The chimney sweep function enables the boiler to be started up in heating mode by pressing both buttons





simultaneously for more than 3 seconds but for no more than 6 seconds.

**On the display, the upper arrow of the maintenance function flashes** and the currently selected temperature appears. This function serves for making measurements on the boiler. When the chimney sweep function is activated, the boiler will deliver maximum output until the limit thermostat cuts out.

To ensure maximum supply of heat, the chimney sweep function generates the forced signal for heat supply. During the time that the Chimney Sweep is activated, an appropriate status code is delivered.

To close the function, press button .

### 8.2.8.2 - Controller Stop function


The controller stop function enables the boiler's heat output to be adjusted manually in heating mode by pressing both buttons   simultaneously for more than 6 seconds.

**On the display, the lower arrow of the maintenance function flashes** and the currently selected temperature appears and the display shows the adjusted relative boiler output.

The function serves for making measurements on the boiler and allows the boiler output to be increased / decreased by pressing buttons



Minimum and maximum output   can be selected by pressing the line selection buttons  

**Note:** - If the controller stop function is triggered via PC tool ACS420, the current setpoint of burner output will appear on the display, but the settings are locked.

To close the function, press button .

### 8.2.8.3 - Time of day function

To ensure that this function operates, the time of day and time settings must be correctly set. Refer to section, Parameter settings for Enduser, to setup the program.

**Note:-** each time button   is pressed during the time setting, the seconds are set to 0 and the clock continues to run while making the setting.

## 8.2.9 - Fault Error code display (LMU6.. version 2.08)

In the event of a nonvolatile LMU... lockout position, fault is continually displayed. In addition, the diagnostic code on the display flashes (refer to figure 8.2.4).

To cancel the lockout position, press lockout reset button  for at least 2 seconds.

### 8.2.9 - Heating circuit operating modes





The control provides 4 different heating circuit operating modes for LMU... heating circuit 1. They can be directly selected depending on the requirements - figure 8.2.9

The operating modes are selected by pressing button .

On the LCD, a pointer below the respective symbol  points to the selected heating circuit operating mode.

**Figure 8.2.9 LMU Error Codes**

<b>Error code</b>	<b>Internal Error-Code</b>	<b>Potential cause</b>	<b>Actions</b>
0		No entry in code	
10		Fault outside sensor	
20	142	Short Circuit Boiler Flow Sensor	Check temp sensor in water flow pipe & replace if necessary
	143	Open Circuit Boiler Flow Sensor	Check connections to temp sensor in water flow pipe Check temp sensor in water flow connection & replace if necessary
28		Fault flue gas sensor	
32		Fault flow temperature sensor 2	
40	144	Short Circuit Boiler Rtn Sensor	Check temp sensor in water rtn pipe & replace if necessary
		Open Circuit Boiler Rtn Sensor	Check connections to temp sensor in water rtn pipe Check temp sensor in water rtn connection & replace if necessary
50		Fault DHW temperature sensor 1	
52		Fault DHW temperature sensor 2	
61		Fault room unit 1	
62		Wrong room unit 1 or wrong radio clock connected	
77		Fault air pressure sensor	
78		Fault water pressure sensor	
81	518	LPB Short Circuit or no power supply	Check connections to clip in (switch off and isolate boiler before working on mains wiring)
82		Address collision on LPB...	
91		Data overflow in EEPROM	
92		Hardware fault in electronics	
95		Invalid time of day	
100		2 clock time masters	
105		Maintenance message	
110/111		Limit thermostat has cut out	Allow the boiler to cool and reset thermostat Investigate cause of overheating (see section 9.3)
113		Flue gas supervision equipment has cut out	
117		Water pressure too high	
118		Water pressure too low	
119		Water pressure switch has cut out	
128		Loss of flame during operation	Check connections to flame probe Investigate flame probe condition Check combustion when boiler is firing
130		Flue gas limit temperature exceeded	
132		Safety shutdown	Check gas pressure Check flue & condensate trap for blockages Check safety switches
133		No flame on completion of safety time	Check operation of gas valve
134		Loss of flame during operation	
140		Inadmissible LPB segment number/device N°	
148		Incompatibility LPB... interface / basic unit	
151	552	Relay clip in faulty	Check connections to clip in Check and replace clip in module (switch off and isolate boiler before working on mains wiring)
152		Fault in connection with LMU settings	
153		LMU has locked out	Press reset button (code appears if reset button is pressed when there are no faults)
154		Flow Problems	Check water flow through the boiler & Check the pumps
160		Fan speed threshold not reached	Check obstructions in fan, burner & flue. Check non-return valve operates Check heat exchanger for debris
161		Maximum fan speed exceeded	
162		Fault air pressure switch (does not close)	
164		Fault heating circuit flow switch / pressure switch	
166		Fault air pressure switch (does not open)	
180		Chimney sweep function active	
181		Controller stop function active	
183		LMU... in parameter setting mode	

Operating mode	Designation	Effect of selection
	Automatic operation	Heating circuit 1 (HC1) according to time switch program 1
	Standby	Heating circuit 1 switched off Frost protection functions active
	Continuous 'Normal' operation	Heating circuit 1 continuously on according to the adjusted nominal room temperature setpoint or heating circuit setpoint
	Continuous 'Reduced' operation	Reduced room temperature set point or heating circuit frost protection setpoint

**Figure 8.2.10 Operating Mode Symbols**

### 8.2.11 - Display of operating phases (display level A4)

The operating phases according to the LMU...’s sequence diagram can be displayed (display level A4 press Info button 3 times).

Assignment of the display code and the LMU...’s phase designation is as follows:

Display	Meaning	Internal operating phases of the LMU...
00	Standby (no demand for heat)	PH_STANDBY
01	Prevention of startup	PH_STARTVER
02	Fan runup	PH_THL1_1 PH_THL1_2
03	Prepurging	PH_TV
04	Waiting time	PH_TBRE PH_TW1 PH_TW2
05	Preignition time	PH_TVZ
06	Safety time, constant	PH_TSA1_1 PH_TSA2_1
07	Safety time, variable	PH_TSA1_2 PH_TSA2_2
10	Heating operation	PH_TI PH_MODULATION Heating mode
11	DHW operation	PH_TI PH_MODULATION DHW mode
12	Parallel operation of space heating and DHW heating	PH_TI PH_MODULATION Heating and DHW mode
20	Postpurging with the last control of operation	PH_THL2_1 PH_TN_1
21	Postpurging with control of prepurging	PH_THL2_2 PH_TN_2
22	Home run	PH_TNB PH_TLO PH_TNN
99	Lockout position (display of the current error code)	PH_STOER

**Note:** -If operating phases are passed very quickly or skipped, the relevant display code will not appear.

## 8.3 - Functions

### 8.3.1 Frost Protection

Note: - to access this function, the circulating pump must be wired to the LMU through a suitable contactor.

There are two levels of frost protection available dependent on the sensor options used.

1st stage - When the boiler water temperature is below 5°C, the burner and the heating pump are switched on. When the temperature increases and exceeds 15°C, the burner stops and the pump continues for the duration of the pump overrun.

2nd stage - This additional function uses the outside air temperature (if a sensor has not been fitted, the function is blocked) and provides three levels of activation.

- If the outside temperature is less than or equal to -5°C, the pump operates continuously
- If the outside temperature is between -4 & 1.5°C, the pump operates for 10 minutes every 6 hours.
- If the outside temperature is greater than 1.5°C, the pump is switched off.

Note:- any demand for dhw is given priority.

Should protection be required for the building fabric, then a QAA73 programmable room sensor must be used to maintain the internal building temperature.

### 8.3.2 Anti Legionella

To prevent the development of pathogenic bacteria in the domestic hot water tank during prolonged shut downs or low storage temperatures, the dhw must be heated once a week to a temperature greater than 60°C.

The anti legionella function heats the dhw once a week on Monday, after the first load, to 65°C.

### 8.3.3 Pump overrun

When the heating mode ends, the heating circuit pump remains on for a period (depending on the settings used - QAA73: 544).

In dhw systems, when the dhw heating period ends, the heating pump remains on until the return temperature drops below 70°C. During this period, the dhw selector valve (if fitted) is in the open position.

### 8.3.4 Pump or selector valve kick

If either the heating circuit pump or dhw selector valve have not been activated for more than 24hours, then during an off period the pump or valve is activated for 5 seconds.

### 8.3.5 Boiler overheat protection

The boiler flow sensor in combination with the return sensor, provide overheat protection as follows:

- If the first level temperature is exceeded, a fault code is displayed.
- If the second level temperature is exceeded, an alarm code is displayed and the boiler will switch off. The boiler must be reset to restart.

To restart the boiler, the temperature must fall, accordingly the fan and pump will continue to operate until the boiler heat exchanger temperature drops.

Additionally, should the  $\Delta T$  across the boiler heat exchanger exceed 25°C, the burner will reduce output to minimum rate. Should the  $\Delta T$  exceed 30°C, the burner will shutdown.

### 8.3.6 Anti-cycling

Dependent on the installation and the minimum firing rate of the boiler, the control monitors the heating temperature curve and will hold off a boiler from firing and thus reduce the number of operations.

### 8.3.7 Automatic summer / winter switching

Note: - This function is only available when an outside sensor is fitted.

The automatic summer/ winter switching function enables the summer mode to be switched to winter mode (vice versa) throughout the year, without the need for manual intervention.

The heating is shut down when the average outside temperature measured over the preceding 24hours is greater than 1°C above the set point (20°C).

The heating is automatically started up again when the average outside temperature measured over the preceding 24hours is less than 1°C below the lower limit of the hysteresis threshold of the set point (18°C).

Note: - The switch over setting is set to 19°C and can only be changed using the QAA73 room sensor.

The automatic mode must obviously be activated on the boiler as well as on the QAA73, for the function to operate. The function is automatically activated by a default setting in the QAA73.

### 8.3.8 - Start-up / initialisation

On startup after power-On, or after a lockout reset, the setpoints will be initialized.

These setpoints apply until a first adjustment is made (e.g. via the display or PC parameterization):

After a readjustment, these values will be overwritten with the new value and permanently stored in the LMU.

When a new startup is made, or after power-On, the previous settings will be stored in the LMU.

Also, the software version number of the operator module and that of the connected type of LMU... will be delivered to the display.

### 8.3.9 - BMS 0~10v DC control of LMU

**Before programming changes are made, ensure the boiler is set to standby mode.**

The following parameters need to be changed on the boiler LMU when a BMS 0-10 V signal is being used to control the boiler modules directly. All parameters can be changed using the keypad on the boiler display panel or via the computer link using the Siemens software.

Press and hold both up and down arrow keys for at least five seconds to enter advanced parameter list H90 displayed top right of HMI screen.

Use either up or down arrow key to scroll through the parameter list and stop at H618 - Default value is 0

Two options for control are available :

Option 1 (preferred option for multiple boilers on a modulating 0-10V signal controlling the load)

To enable 0-10v control over the boiler power range, change the setting by using the + or – key and set value to 5. Press mode button to store change and return to home screen.

Option 2 (if the 0-10V signal is only being used to enable the boilers and is not modulating)

To enable 0-10v control over the boiler temperature set point, change the setting by using the + or – key and set value to 4. Press mode button to store change and return to home screen

Press and hold both up and down arrow keys for at least five seconds to enter advanced parameter list H90 displayed top right of HMI screen.

Use either up or down arrow key to scroll through the parameter list and stop at H622 - Default value is 80

Change this value to match the required flow temperature set point at maximum (10v) e.g. 80 = 80°C max set point. Press mode button to store change and return to home screen

0-10v signal wiring can now be connected to connections 15 and 16 of the terminal rail to control the boiler.

<u>Boiler</u>	<u>PC</u>	<u>Req'd setting</u>	<u>Function</u>
618	526	4	0–10 V - temperature
618	526	5	0–10 V - load (preferred option for modulating load)
622	528	As req'd (80°C)	Max temp = 10 V
623	529	As req'd (20%)	Min % load = 20 %

It may be necessary, depending on the operating temperature required, to raise the maximum operating temperature possible from the individual boiler modules. As standard the boiler modules leave the factory with a maximum operating temperature of 85°C. Where a higher operating temperature is required the following parameter change must be made.

505 181 As req'd (90°C) Max operating temp.

### 8.4 - Access to LMU Fault Log

The LMU control retains historical fault information of the last 6 faults, as read only via the Engineer level access. The current fault relates to the actual lockout at the time of the visit. Once reset, the current fault becomes the 1st fault and the remaining history is shifted back to the 5th fault, losing the previous 5th fault history.

The Albatros code is the 'E' display code supported by the internal code. See figure 8.2.9

#### **Note :**

When connecting to a QAA73 unit refer to Hamworthy OEM manual 500001140

When connecting to a Merley control unit refer to Hamworthy OEM manual 500001210



Figure 8.3.11 - Operating phases

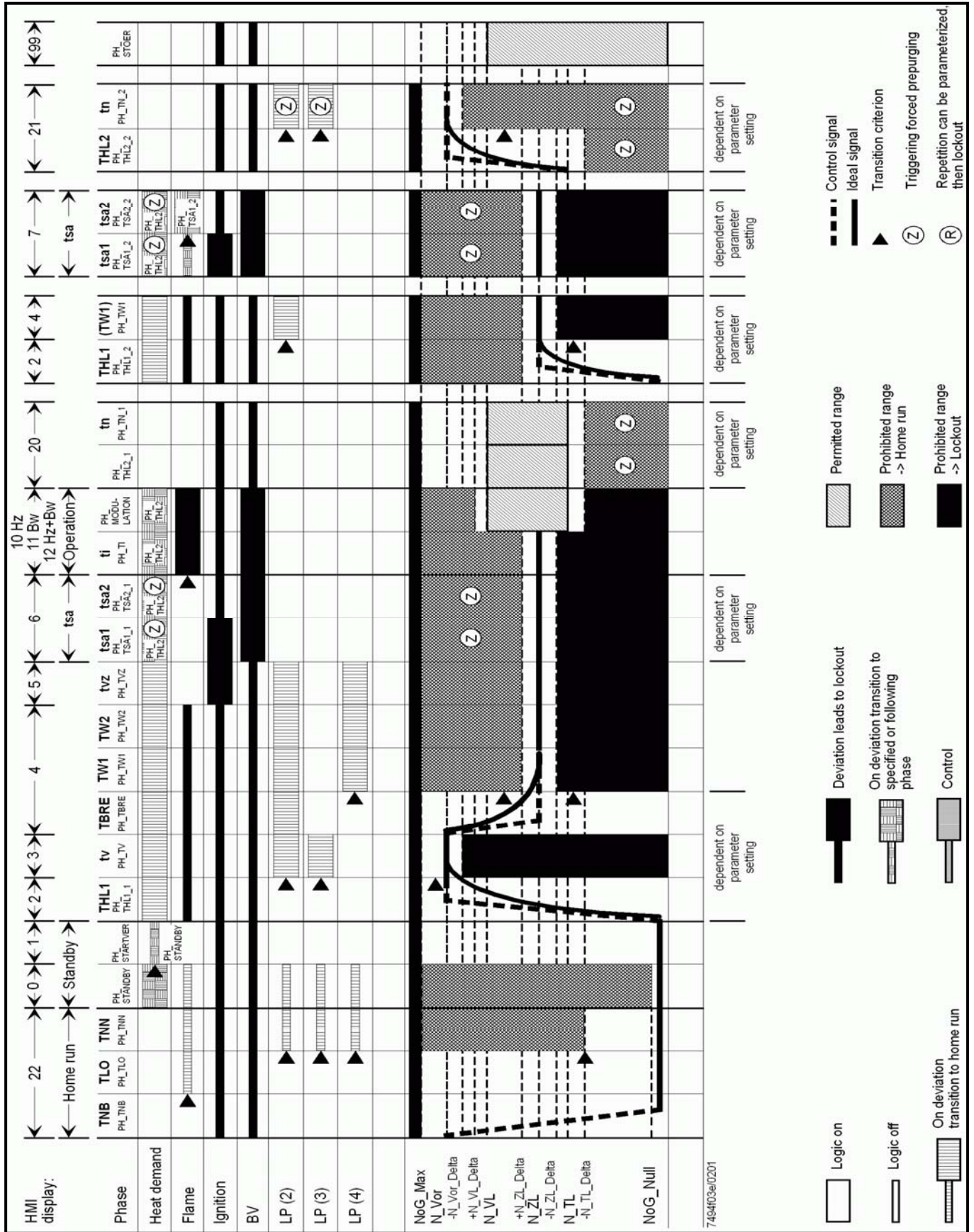
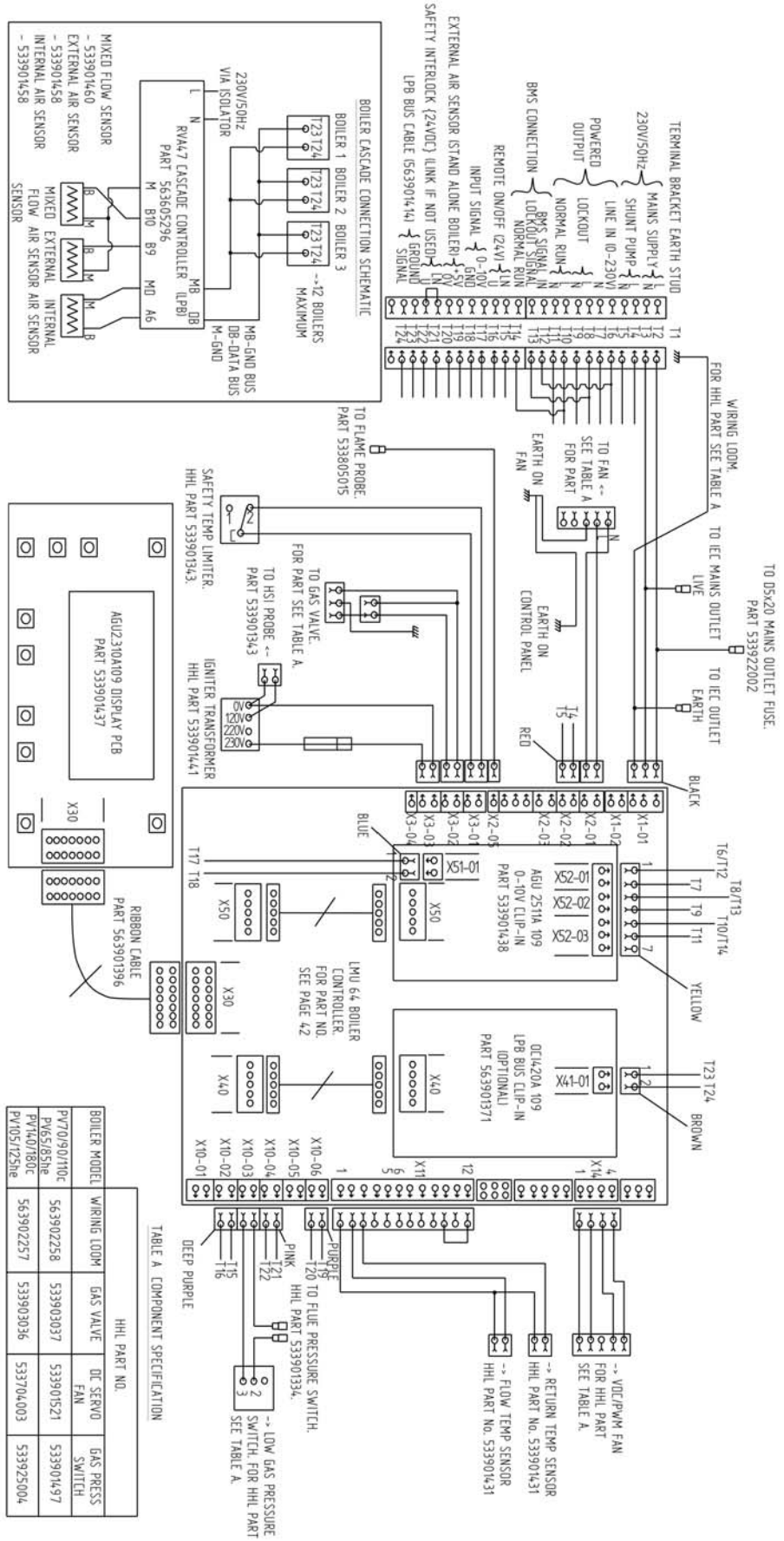


Figure 9.0 Boiler Wiring Schematic



## **9.0 FAULT FINDING**

The Purewell VariHeat boiler is equipped with full self diagnostic fault indication, which is displayed on the screen - refer to **section 8.2.1 - Controls Operation**.

**Should a fault occur which cannot be reset, or a fault repeatedly occurs, contact Hamworthy Heating for assistance. Do not continue to operate or use the boiler as this may cause damage to the boiler or controls.**

### **9.1 Safety Features Summary**

#### **9.1.1 Safety Temperature Limiter**

1 The electronic control thermostat has several safety levels built in such that a controlled shutdown should occur before the limit thermostat is activated. Should these safety levels be overridden (say external pump overrun failure after shutdown) the temperature limit thermostat will trip initiating a boiler shutdown, preventing the boiler from firing.

Should the control thermostat fail, causing an overheat condition, the safety temperature limiter will trip thus creating an immediate shutdown regardless of firing mode. An overheat message on the **controls fascia** will indicate that this condition has occurred. The limiter thermostat is reset by depressing the reset pin protruding through the hole in the centre of the controls fascia. If, after pushing the pin in, the display screen does not reset and the boiler does not light up, it could be that the boiler is still too hot, i.e. the control thermostat has not re-set. An investigation should be carried out to ascertain the reason for the overheating. An obvious reason would be too low a water flow rate through the boiler.

#### **9.1.2 Flame Probe**

The flame is under constant supervision by the burner logic controller through use of a flame probe. This is accomplished by measuring the flame's ability to rectify an AC current. If the flame diminishes for whatever reason and the rectified current drops below the controllers minimum (0.8µA DC), the controller will induce a non-volatile lockout which will require a manual re-set ('on/off button situated on the controls fascia) to re-start the control sequence. .

### **9.2 Fault Finding Procedures**

General error messages are detailed in section 8 to assist with fault finding. If the boiler still cannot be operated satisfactorily after following the instructions, consult your Hamworthy Heating for assistance.

### **9.3 Possible Causes of Boiler Lockout**

- 1) Ignition failure due to faulty igniter.
- 2) Ignition failure due to faulty gas valve.
- 3) Ignition failure due to No or low gas supply pressure.
- 4) No ignition due to faulty controller.
- 5) Ignition failure due to faulty flame probe or sensing circuit.
- 6) High temperature
- 7) Unnecessary pressing of reset when boiler is running

**Should a fault code appear which cannot be reset, or a fault code repeatedly occurs, contact Hamworthy Heating for assistance. Do not continue to operate or use the boiler as this may cause damage to the controls.**

## **10.0 SERVICING**

**A competent person registered for working on non domestic gas appliances should check and ensure that the flue, its support and terminal, the ventilation to the boiler house, safety valve, condensate trap, drain, water filter if fitted, pressure gauge etc., are in a serviceable and working condition, and still comply with the relevant standards and codes of practice - see Section 4 & Appendices**

**10.1 Regular servicing is recommended**, preferably by a Hamworthy appointed person, and at least annually, to ensure trouble free operation.

For the Purewell VariHeat, Hamworthy would recommend an additional 6 monthly examination following commissioning, acknowledging site conditions and running hours.

Although cleaning of flueways may not be necessary on a yearly basis inspection of the flueways must be undertaken annually and it is important that all controls and safety features are checked for correct operation.

**NOTE!** Measuring flue gas CO<sub>2</sub> and gas temperatures will give an indication of the state of the boiler flueways and waterways. Results should be compared with previously measured values to establish possible loss of efficiency.

**Should remedial work be carried out on a boiler within a bank of boilers, then the non-firing module must be**

**electrically isolated so as to prevent accidental operation., in the event that the installation is required for ongoing heating requirements.**

**10.2** The procedure detailed relates to a single boiler and must be carried out on all boilers within a bank. Before servicing the boiler, the following procedure must be carried out: -

**WARNING: Isolate the electrical supply and turn off the gas isolating valve to the boiler being serviced.**

1) To remove the front casing door, remove the four 1/4 turn screws securing the fascia moulding. Pivot the fascia moulding about its bottom edge to 45 degrees and lift off. Store in a safe place to avoid damage. Remove the two 1/4 turn screws securing the front casing door and lift off from the front brace. Remove the two 1/4 turn screws fixing the top panel and slide the panel in the direction of the rear of the boiler to disengage from the securing pins on the back panel.

2) Turn off gas service cock.

3) Disconnect the gas valve plug assembly from the gas valve & the low gas pressure switch plug. Disconnect the gas valve inlet flange from the gas valve. Disconnect the 3 & 5 way electrical plugs from the fan body.

4) Disconnect igniter and probe leads. Disconnect the fan/gas valve assembly from the burner body by removing the 4 M8 nuts securing the transition duct to the burner. Carefully place the fan/gas valve to one side.

5) Loosen the 4 - M8 nuts securing the burner clamping flange to the tie rods and carefully remove the clamp. The burner assembly can be removed by withdrawing upwards (**care is required when removing the burner as the Hot Surface Igniter element is fragile**). Check condition of igniter assembly and probe for damage. Clean as required. Check burner surface and clean using a soft brush if required (if possible use compressed air to blow out the dust inside the burner. A damaged burner must be replaced.

6) Examine the non return valve located in the fan/burner duct for free operation and integrity of the foam seal. Replace if necessary.

7) The procedure to disconnect the fan from the boiler so the fan impellor can be inspected & cleaned using a soft brush & compressed air is as follows.

I) For models PV70c/95c/110c (Refer to Figures 11.2.& 11.3 for parts assembled between the gas valve & fan )

A) Disconnect the silicon tube attached to the gas valve.

B) Disconnect the gas valve from the air box lid by removing the screws in the square flange of the lid.

C) Remove the screws securing the air-box from its lid.

D) Unscrew the screws fixing the venturi to the metal plate moulded in the airbox.

E) Remove the screws behind the venturi fixing the airbox to the fan.

II) For Models PV140c/180c (Refer To Figure 11.4 For Fan/Gas Valve Assembly) remove the screws attaching the metal bracket & plastic venturi to the fan.

A) Remove the screws securing the gas valve to the corrugated gas supply pipe.

B) The subassembly of gas valve, metal bracket & plastic venturi can be carefully removed for access to the fan.

**10.3** The boiler flueways can now be cleaned as follows:-

**1) Remove the inspection panel secured to the front base of the boiler must be removed.**

2) Using a suitable brush, clean the vertical fins on the castings below the burner.

3) Using a torch, inspect the fin matrix of the secondary heat exchanger situated below the cast iron sections and clean using compressed air or a water hose. Any debris dislodged can be removed from the sump through the inspection panel.

4) Re-assemble the boiler in the reverse order to that shown above. Ensure a new seal is fitted to the top casting / burner joint to maintain a gas tight seal, (see spares list). Ensure that a new seal is fitted to the inspection panel. The boiler's operation may be affected if these seals are do not form a gas tight joint.

5) Re-assemble the burner and clamp plate to the top casting and secure using the M8 nuts and tie rods, ensuring that the joint is sound. Assemble the gas valve, fan, transition duct using new gaskets. Refit the gas inlet flange to the gas valve using a new 'O' ring. Check all gas connections are tightened securely before opening the gas service cock. Re-connect electrical connections. Switch on the electricity supply and re-light the boiler following the procedure detailed in section 7.3.

6) Take exhaust gas readings and compare with section 7.4. Ensure no gas leaks are evident from the gas connections, refer to section 7.1 for procedure. Check thermostat settings and adjust if required.

7) Re-fit casing panels and tidy floor around boiler as necessary.

## **11.0 REPLACEMENT OF FAILED COMPONENTS**

There are a number of components listed below which can be replaced simply and quickly by following the given procedure. In each case carry out the appropriate part of the commissioning procedure & check the operation of each component replaced. See **Section 7.3:Commissioning and Testing**

**NOTE: Isolate electrical supply to the boiler and turn off the gas supply after removing controls cover and before commencing any servicing or component exchange procedure.**

### **11.1 Igniter and Flame Probe Assembly**

**Both Ignitor and flame probe are secured in the same manner.** Reference to Figure 11.1 shows position of igniter assembly. To remove assembly disconnect the plug/socket on the supply lead and remove the screw securing the igniter to the burner front panel. Figure 11.1 shows diagram of igniter assembly and relevant components. Generally remove any loose sooty deposits and clean as required. Before renewing the Hot Surface Igniter ensure the protective sleeve is removed from the new Igniter (**care is required as the Igniter element is Fragile**). Ensure positions of components are as recommended in Figure 11.1.

### **11.2 Safety Temperature Limiter (Limit Stat)**

With the boiler front cover removed, the Limit Stat is situated on the rear of the control panel fascia bracket to the left hand side of the main PCB. Remove the 'push on' spade connections from the temperature limiter body noting position of coloured cables. Remove plastic cover (if fitted) and unscrew holding nut to detach temperature limiter from housing. Gently feed the capillary back through the controls bulkhead. Re-set temperature limiter to 95°C. Check the operation of the device by carefully applying a heat source to the bulb. Re-assemble temperature limiter into controls housing ensuring correct cable notation. Refer to Figure 9.0.

### **11.3 Main Gas Valve.**

**NOTE!** Hamworthy Heating strongly recommend that a new gas valve assembly is fitted to ensure safe, reliable operation of the boiler. **The gas valve is supplied as a factory set component & must not be tampered with.**

1) Disconnect the gas valve electrical plug.

Remove the four socket head screws securing the gas valve inlet flange. Take the weight of the gas valve and remove the four socket head screws securing the gas valve to the discharge pipe assembly. Withdraw the gas valve.

2) Always fit new 'O' rings to both inlet and outlet when replacing the gas valve.

Always test for gas soundness after replacement parts have been fitted.

Refer to **Section 7.1**, if necessary for valve integrity check procedure.

3) Re-light the boiler using instructions on the inside of the door. Check for correct operation. If necessary, refer to **Section 7.4 Commissioning the Boiler**, for correct procedures.

### **11.4 Combustion Fan**

**NOTE!** To remove the fan, it is necessary to remove the gas valve & airbox (PV70c/90c/110c), or remove the metal bracket fixing the venturi to the fan (PV140/PV180c).

Replacement on Models PV70c/PV95c/PV110c

1) Disconnect the gas valve plug assembly from the gas valve. Disconnect the gas valve inlet flange from the gas valve. Disconnect the 3 & 5 way electrical plugs from the fan body.

2) Disconnect the fan/gas valve assembly from the burner body by removing the 4 M8 nuts securing the transition duct to the burner.

3) Remove the screws securing the airbox lid to the airbox and carefully store the lid & gas valve assembly.

4) **Note correct orientation of the venturi with baffle** & remove the screws of the venturi. Remove the screws securing the airbox to the fan. Carefully store all of the air inlet box components.

5) Remove the screws securing the fan outlet to the burner transition duct. Beware there is a non return valve fitted between these components.

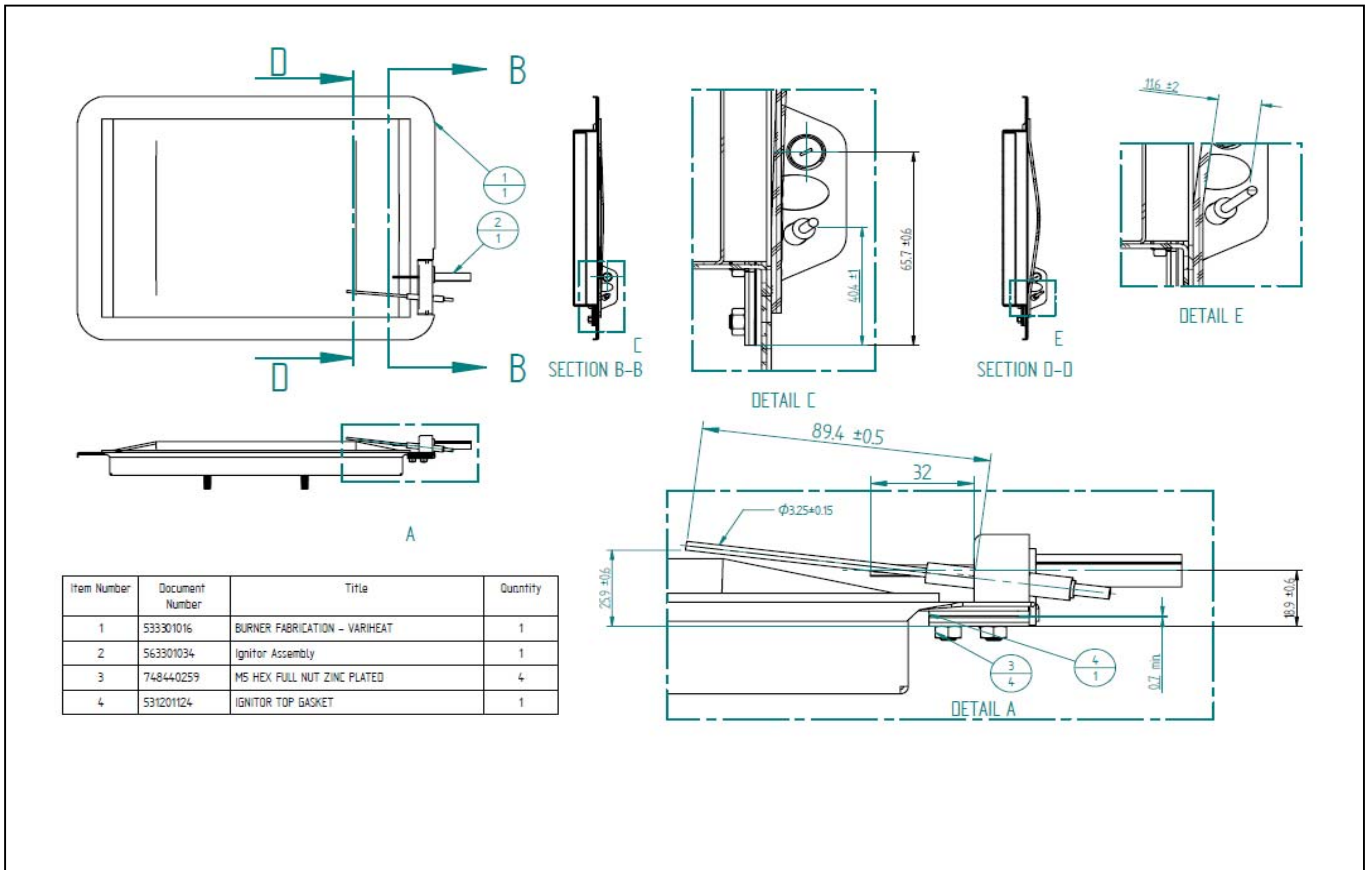
6) Re-assemble in reverse order using new gaskets where appropriate. After assembly and prior to re-fitting the assembly to the burner, check for correct and free operation of the non return valve in the burner transition duct.

Replacement on Models PV140c - PV180c

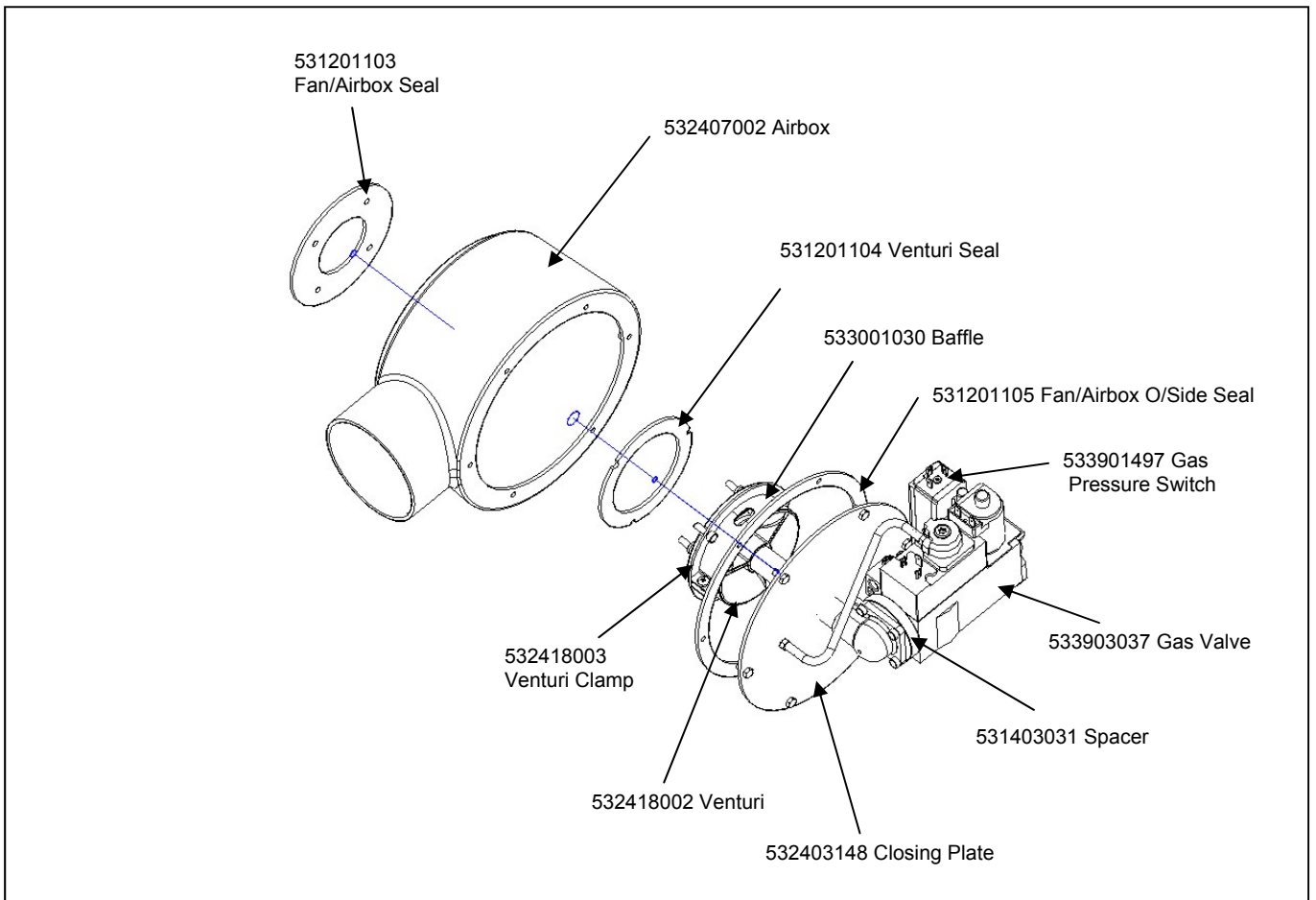
1) Repeat Steps 1 & 2 above.

2) Unscrew the metal bracket from the gas valve & fan. See Figure 11.4.

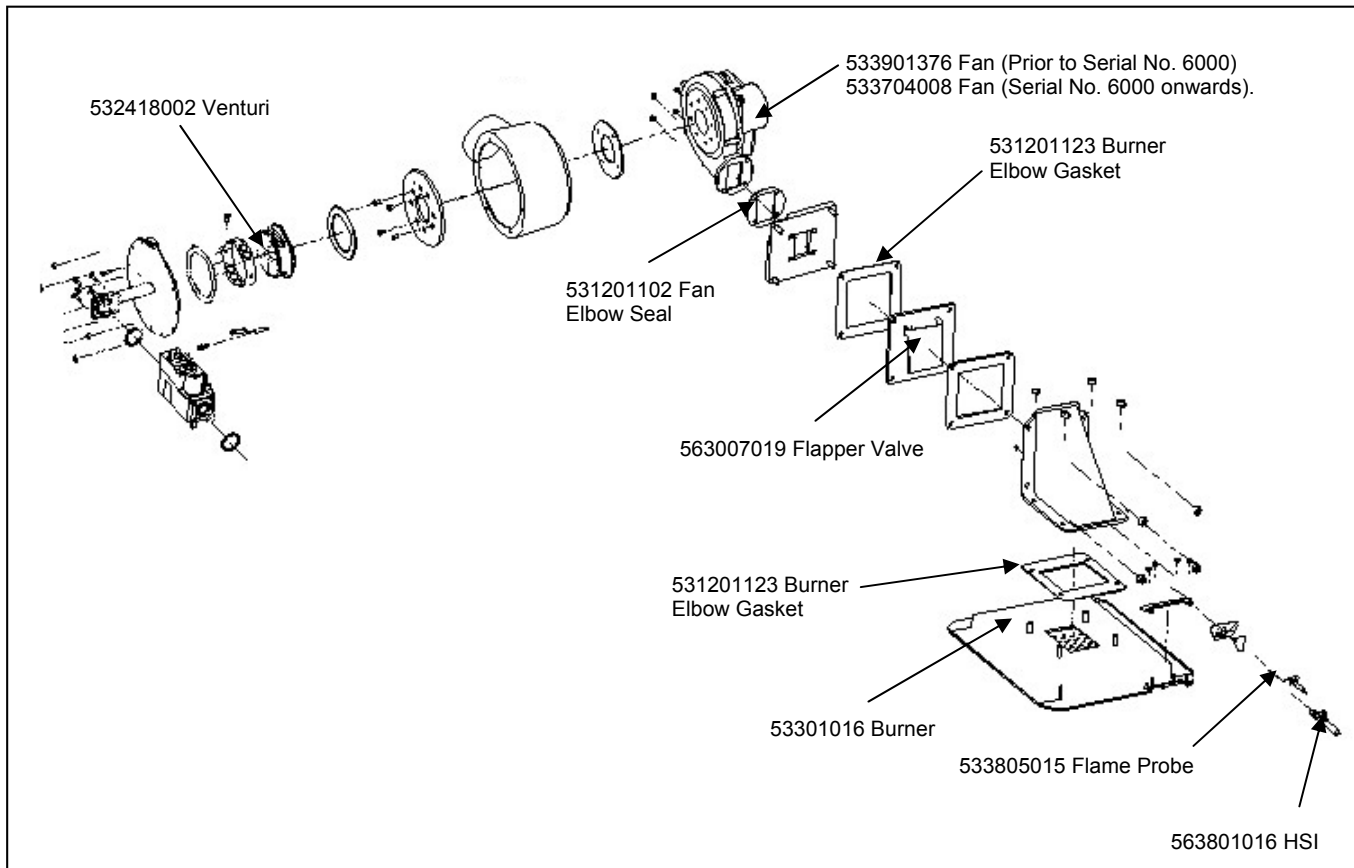
3) Repeat Step 6 above.



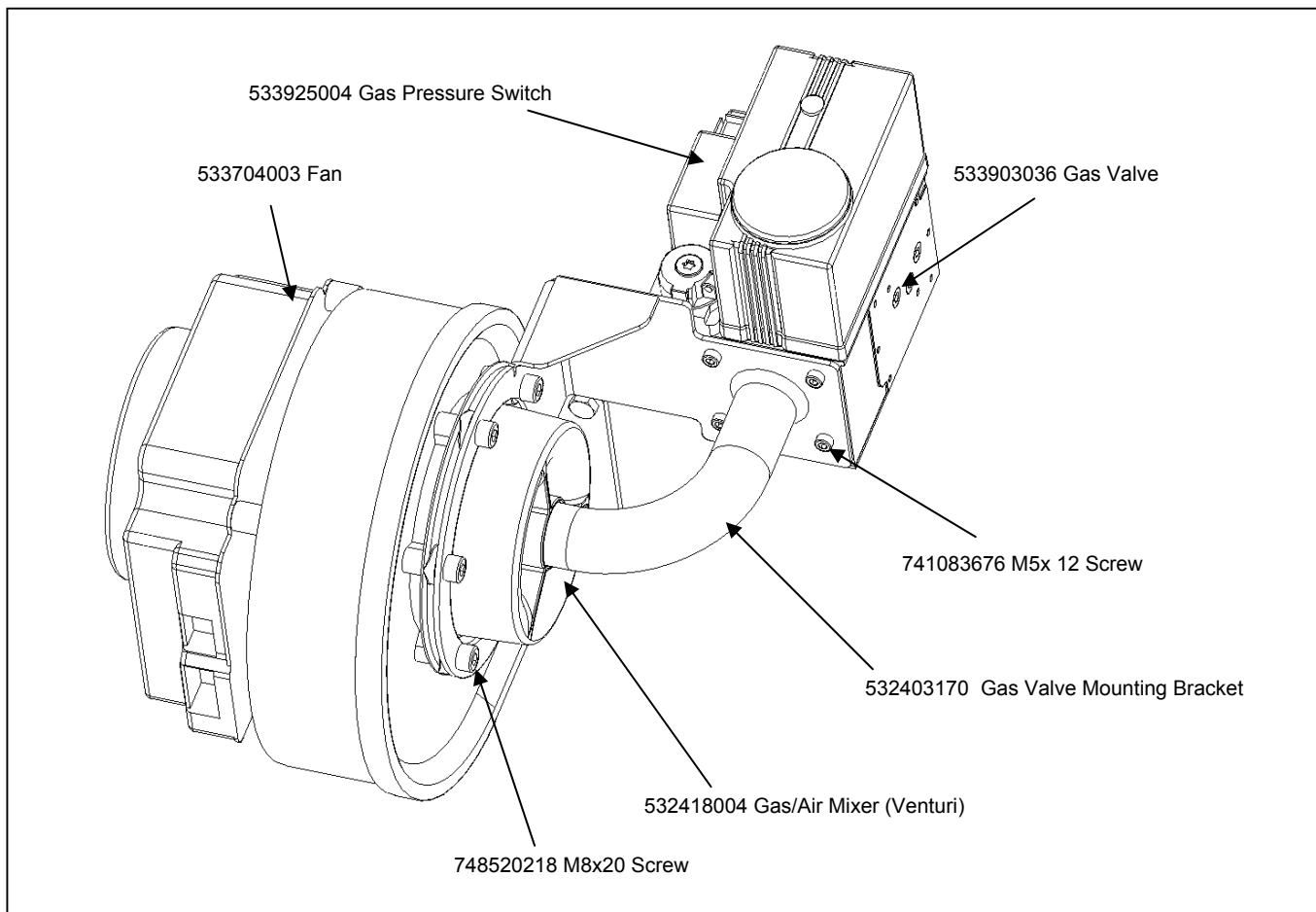
**Figure 11.1 - Hot Surface Igniter and Flame Sensing Probe Positions**



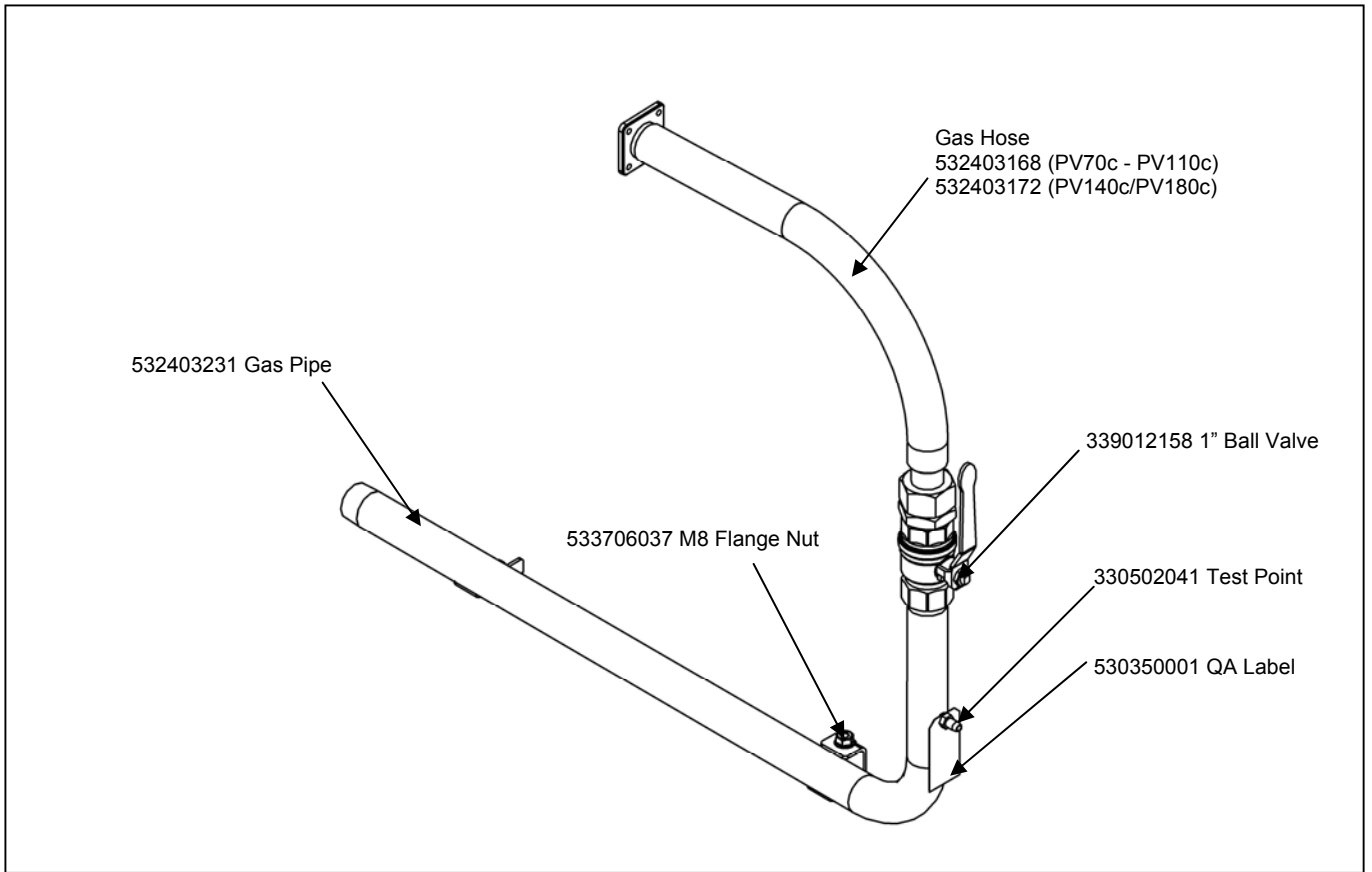
**Figure 11.2 - Gas Valve Assembly ( model 65he - 85he shown for illustration)**



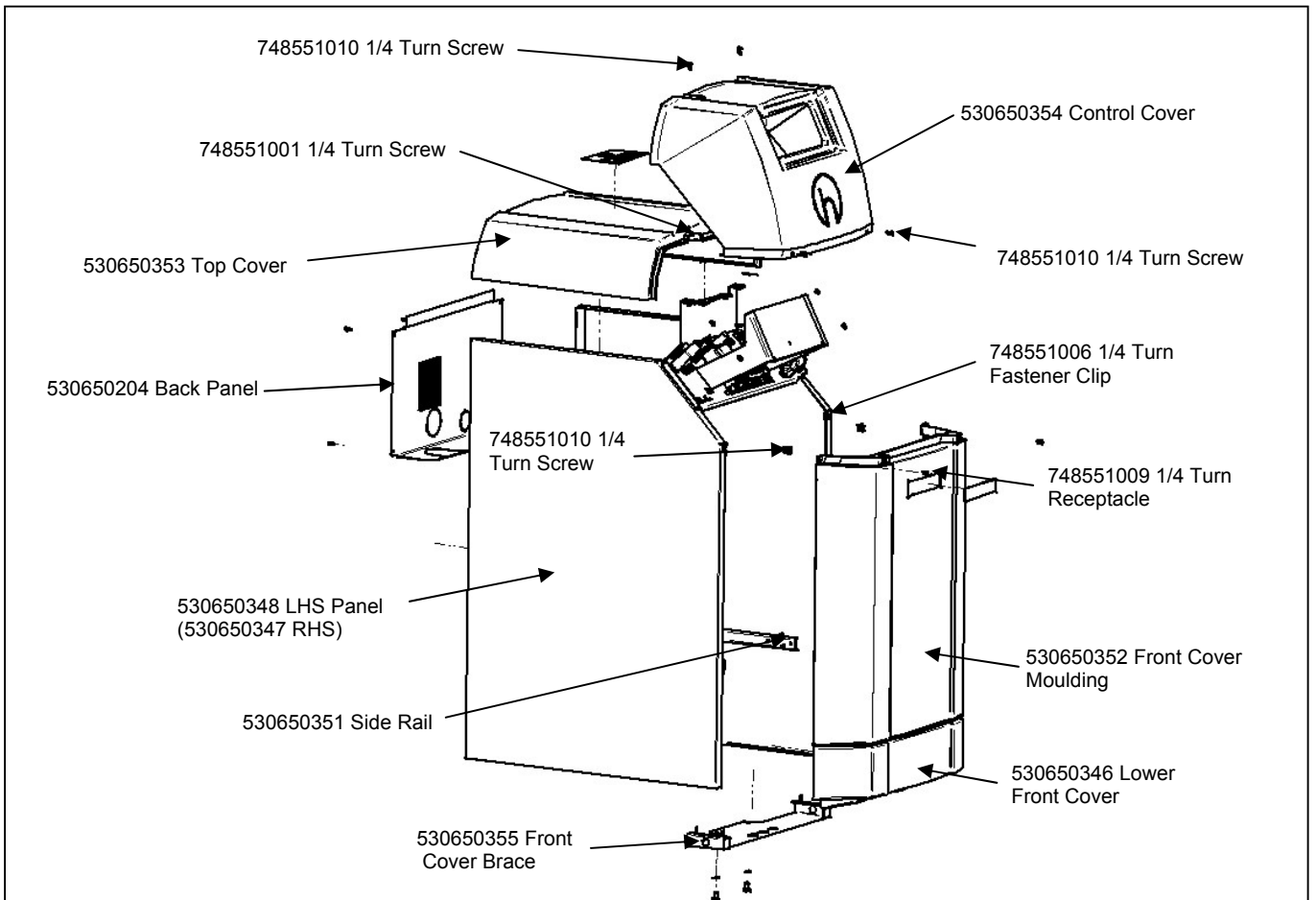
**Figure 11.3 - Combustion System Assembly ( model 65he - 85he shown for illustration)**



**Figure 11.4 - Combustion System Assembly Models PV105he/PV125he**

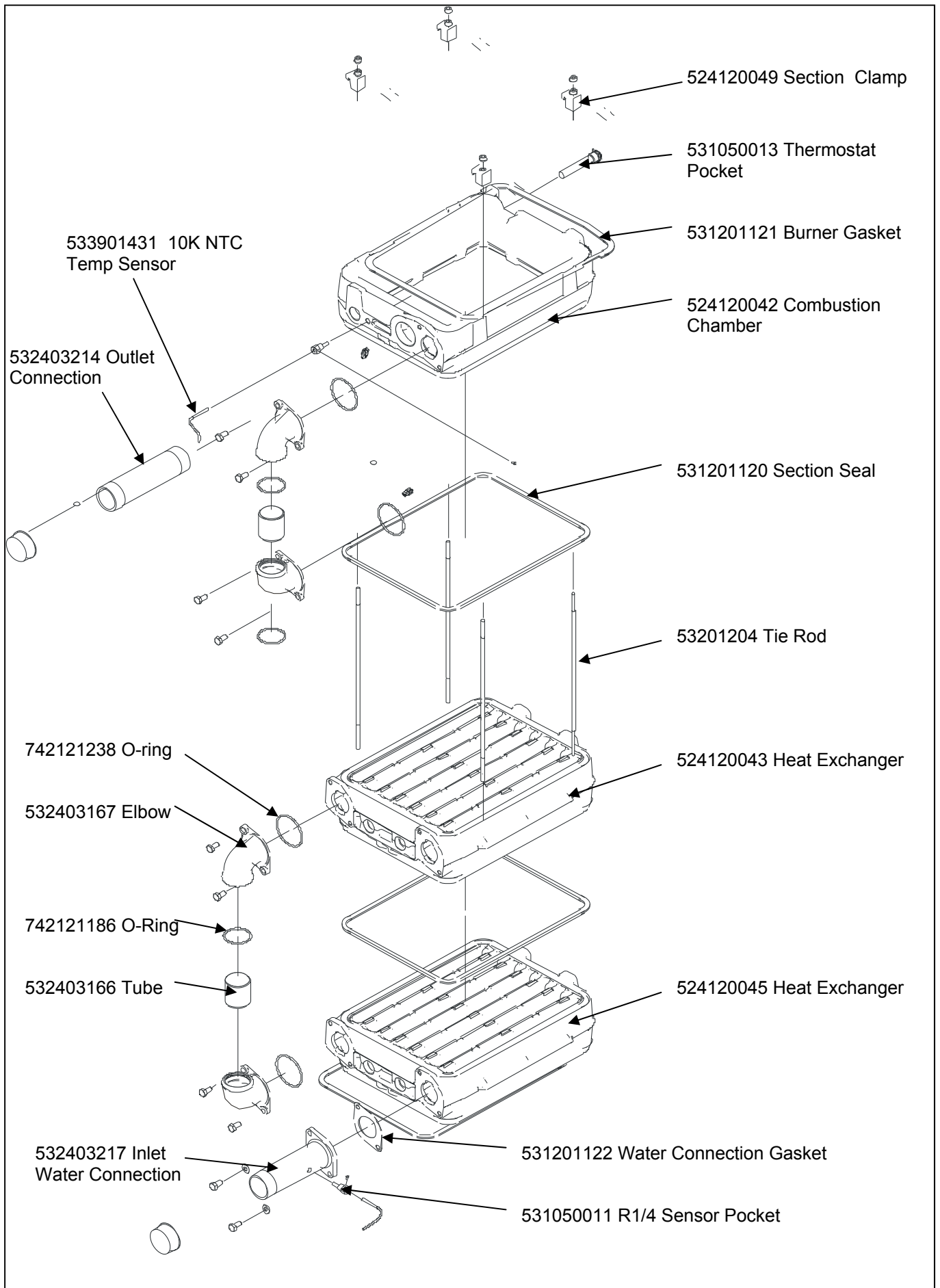


**Figure 11.5 - Gas Train Assembly**

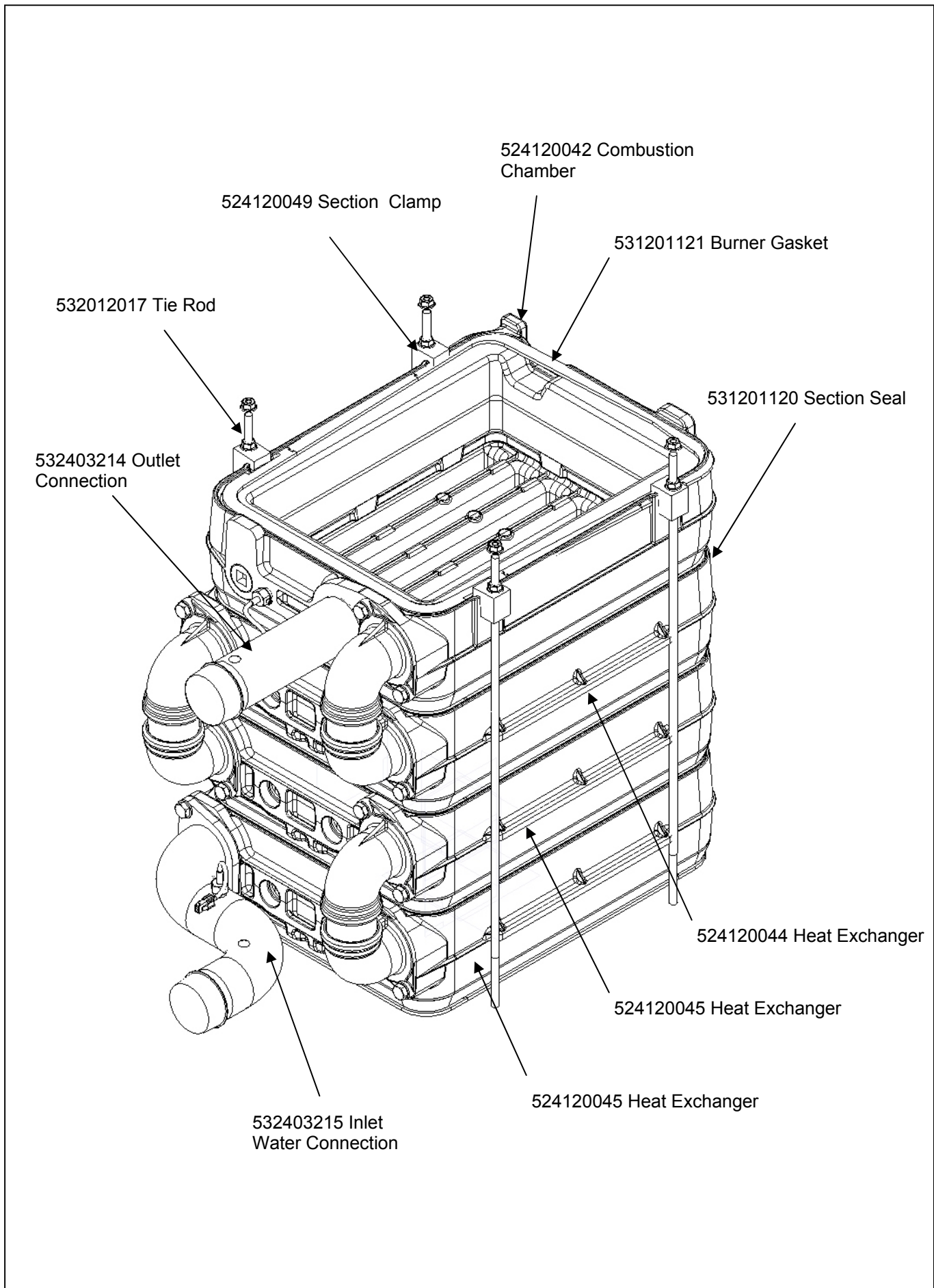


**Figure 11.6 - Casing Assembly**





**Figure 11.7 - Heat Exchanger Assembly ( model 65he - 85he shown for illustration)**



**Figure 11.8 - Heat Exchanger Assembly ( model 105he - 125he shown for illustration)**

## **12.0 RECOMMENDED SPARES**

**Please Note:-** To ensure the correct spare parts are despatched by our spares department, it is imperative that the complete Boiler/Module/Control Panel Serial Numbers are given. The Boiler and Module Serial Numbers are located on the Data Plates affixed to the front of the heat exchanger base casting The Electrical Serial Number is located inside the Control panel on the maximum power rating label. These numbers **MUST** be quoted when ordering spare parts.

### **SPARES ITEM**

### **PART No.**

#### **ELECTRICAL ITEMS**

LMU 64 Boiler Controller - 65he .....	533901517
LMU 64 Boiler Controller - 85he .....	533901518
LMU 64 Boiler Controller - 105he.....	533901519
LMU 64 Boiler Controller - 125he.....	533901520
AGU2.310A109 Display PCB.....	533901437
Flow / Return Sensor.....	533901431
Temperature Limiter.....	533901179
Hot Surface Igniter (HSI) Replacement Kit.....	563605626
Flame Sensing Probe.....	533805015
T2A 5x20 Fuse .....	533922002
T1A 5x20 Fuse .....	533922013

#### **MECHANICAL ITEMS**

Burner.....	533301016
Gas Valve (65 he - 85 he).....	533903037
Gas Valve 'O' Ring (65 he - 85 he) .....	531299018
Gas Valve (105 he - 125 he).....	533903036
Gas Valve 'O' Ring (105 he - 125 he).....	531299032
Combustion Fan (65 he - 85 he) .....	533904008
Combustion Fan (105 he - 125 he).....	533704003
Air Pressure Switch.....	532496004
Low Gas Pressure Switch (65 he - 85 he).....	533901497
Low Gas Pressure Switch (105 he- 125 he) .....	533925004
Set of Gaskets (Routine Service - combustion system).....	563605342
Set of Gaskets (Major Service - combustion system plus heat exchanger) .....	563605343

For service or spares please contact :-

**Hamworthy Heating Limited**  
**Fleets Corner**  
**Poole**  
**Dorset BH17 0HH**

<b>Phone Number.....</b>	<b>01202 662500</b>
<b>Fax Number.....</b>	<b>01202 665111</b>
<b>Service .....</b>	<b>01202 662555</b>
<b>Spares .....</b>	<b>01202 662525</b>
<b>Technical .....</b>	<b>01202 662566</b>

**APPENDIX A - GAS DATA**

**Natural Gas**

<b>GENERAL DATA</b> <b>Purewell VariHeat he</b>		<b>BOILER MODEL</b>			
		<b>65 he</b>	<b>85 he</b>	<b>105 he</b>	<b>125 he</b>
Model					
Boiler Input (maximum)	- kW (Gross)	80.1	107.5	128.0	154.3
Boiler Input (maximum)	- kW (Nett)	72.1	96.8	115.3	138.9
Boiler Output (maximum) 80/60°C	- kW	65	85	105	125
Boiler Output (minimum)	- kW	21.5	30.1	33.6	39.8

<b>GAS DATA</b>					
Gas Inlet Connection Pipe Thread Size		R1"			
Nominal Gas Inlet Pressure		20			
Maximum Gas Inlet Pressure		25			
Gas Flow Rate (maximum)	- m <sup>3</sup> /h	7.63	10.24	12.49	14.79
Target CO <sub>2</sub> % at High / Low fire ±0.25%		8.5/8.5	9.5/9.0	9.0 /8.5	9.0/9.0

**Figure A1 - Gas Data**

## APPENDIX B - ELECTRICAL CONNECTIONS AND CONTROLS

ELECTRICAL DATA					
Model		65 he	85 he	105 he	125 he
Normal Supply Voltage		230V ~ 50Hz			
Power Consumption (maximum)*	- W	554		667	
Start and Run Current (per boiler)	- A	0.54		0.6	

Figure B1.1 - Electrical Supply

\*Where The max allowable power output from the IEC Outlet is 460 W (fitted with A T2A fuse).

**IMPORTANT: Individual boiler modules must be earthed.**

**The boiler must be isolated from the mains electricity supply in the event of electric arc welding being carried out on any connecting pipework.**

1.1 Wiring external to the boiler must be installed in accordance with the IEE Regulations and any local regulations which apply. Wiring must be completed in heat resistant 3-core cable of 1.0mm<sup>2</sup> cross sectional area. Boilers are normally supplied for connection to a 230 volts, 50Hz mains supply. The BIC 930 control is supplied with a replaceable fuse (T1.25A). External fuses should be 10A for all boiler modules.

1.2 3-Phase Electrical Supplies. Banks of VariHeat boilers and boilers installed in close proximity to each other **MUST NOT** be supplied from different phases of a 3 phase supply. The method of connection to the mains electricity supply must facilitate complete electrical isolation of the single boiler with a separation of at least 3mm in all poles.

1.3 A mains isolator must be provided adjacent to each boiler in a readily accessible position. The supply should only serve the boiler.

1.4 Volt free contact electrical supplies must be isolatable where fitted.

1.5 Further details regarding connection to the electricity supply are given in BS EN 60335, Part 1.

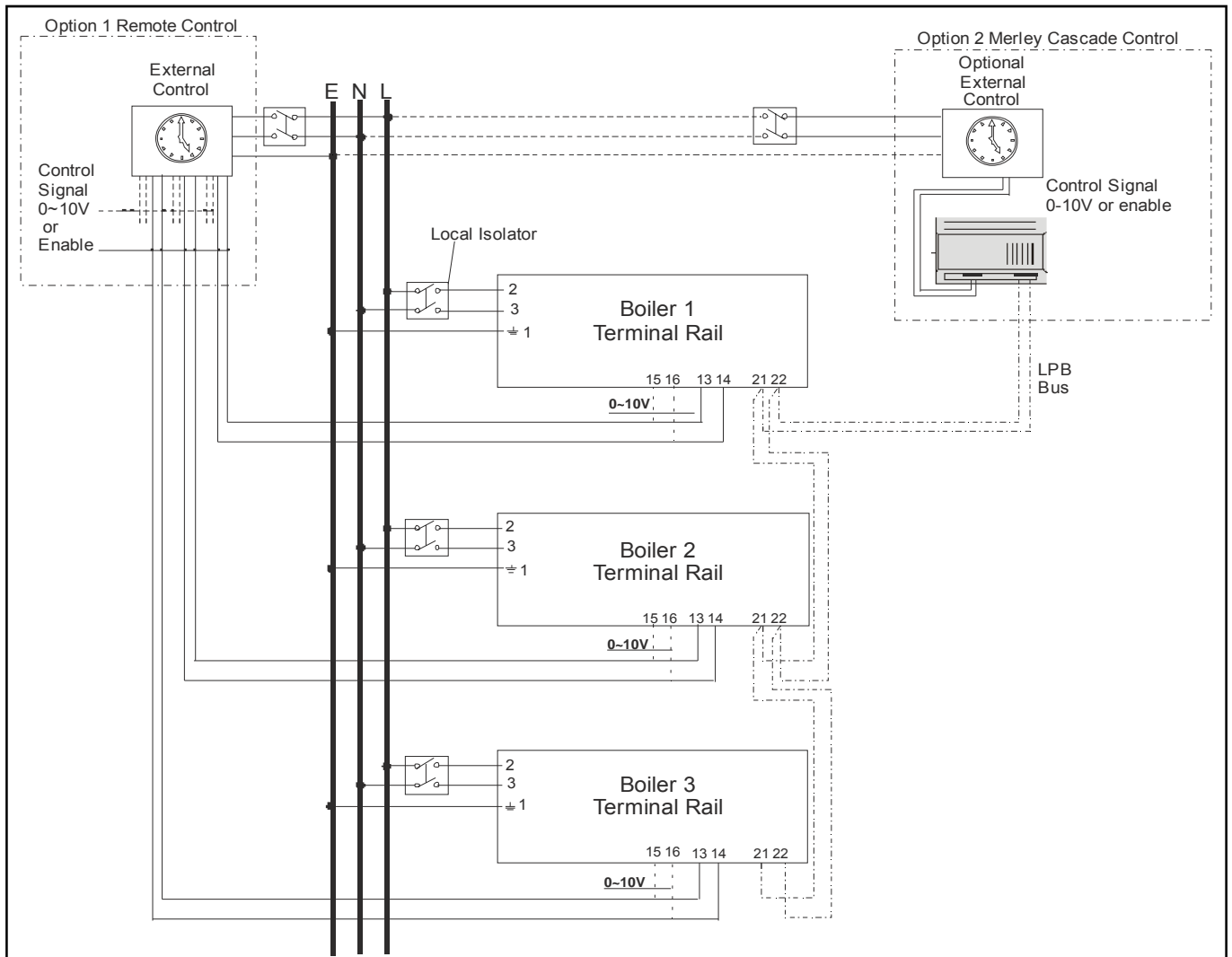
**WARNING: THE MAINS POWER SUPPLY MUST NOT BE SWITCHED BY A TIME-CLOCK CONTROL.**

**CAUTION: DO NOT FEED MAINS VOLTAGE ONTO THE TIMER TERMINALS**

1.6 The mains power supply must be maintained at all times. Each Purewell VariHeat boiler incorporates a remote stop/start loop, which can be used to operate the boiler(s) under a timed regime. The boiler controls provide a 30V DC signal that can be fed through a volt free contact for operation. Refer to BS 6644 for further information on installing the electrical supply.

**NOTE:  
FOR ELECTRICAL CONNECTIONS TO BOILER SEE FIGURE 4.6  
FOR BOILER WIRING SCHEMATIC SEE FIGURE 9.0  
FOR MULTIPLE BOILER WIRING SEE FIGURE B1.2 & B1.3  
FOR CONTROL WIRING SEE FIGURE E1.3.1 TO E1.3.4**

**Figure B1.2 - External Control Wiring for Multiple Boiler Installation**



**Note:-** each module requires independent isolation of electrical supply and control signals.  
Signal cables must not be run in the same conduit as mains voltage cables

- Option 1 - reference should be made to Building Regulations and CIBSE Guide 'Energy Efficiency in Buildings' for controls requirements.
- All modules must be sequenced.
- Enable - will give On/Off control of the modules
- 0-10V - will give modulation control of each module
- Option 2 provides modulation control of up to 16 modules.

## 2.0 - Ignition transformer in-line fuse

From February 2013 (serial no. ending 8094N onwards) an in-line fuse has been introduced on the power supply between the ignition transformer and the main LMU. The fuse is rated at T1A (slow blow) and can be located on the control panel as in fig. B2.0 below.

The condition of the fuse should be checked when investigating a possible LMU malfunction.

HHL part number for spare T1A 5x20 fuse.....533922013

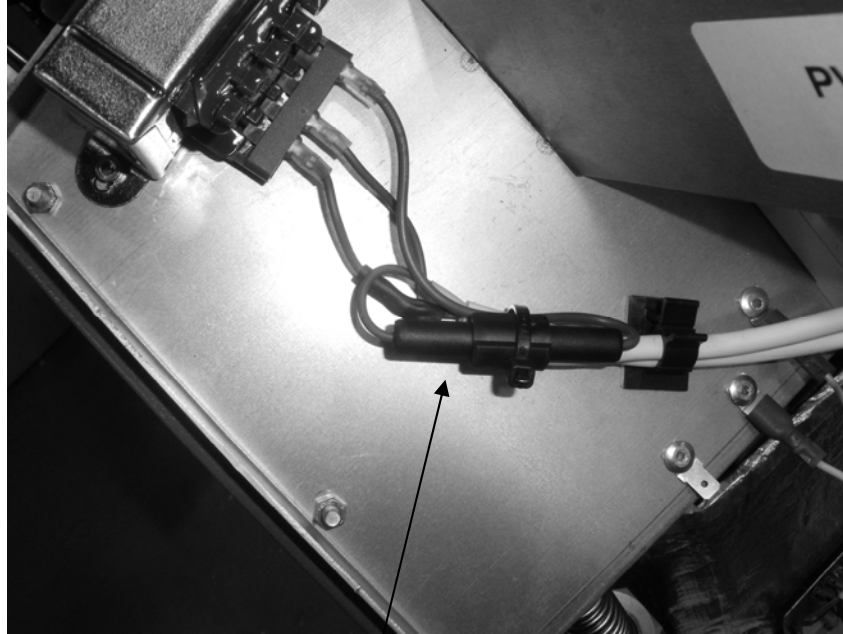


Figure B2.0

In-line Fuse

## APPENDIX C - FLUE DATA

### Natural Gas

FLUE DATA					
Model		65he	85he	105he	125he
Nominal Flue Diameter	- mm	100			
Max back pressure allowable at flue outlet	- mbar	0.9	1.5	1.9	2.5
Approx. Flue Gas Temperature 82/71°C	- °C (Gross)	158	190	146	175
Approx. Flue Gas Volume @ 9.5 % CO <sub>2</sub>	- m <sup>3</sup> /h*	103.00	123.50	156.00	188.00

#### Figure C1—Flue Data

\* **Note:-** Flue gas volumes are corrected to a flue gas temperature of 15°C and barometric pressure of 1013.25mbar.

### C1.0 FLUE SYSTEM

1. Detailed recommendations for flue systems are given in BS 6644, and IGE/UP/10. All flue discharges for plant exceeding 135kW net input must comply with the third edition of the 1956 Clean Air Act Chimney Memorandum.

**WARNING: THE FLUE DISCHARGE FROM A VARIHEAT BOILER WILL GENERATE A PLUME AT THE TERMINAL EXIT. THIS MUST BE CONSIDERED WITH REGARD TO TERMINAL LOCATION AND ADJACENT BUILDING FABRIC.**

#### C1.1 General Requirements

For single boiler installations only the Purewell VariHeat c series of boilers are designed to be used with a forced draught flue system. Flue systems should be designed in accordance with regulations and with reference to BS 6644 and IGE/UP/10.

##### Open (Natural draught ) Flue.

Type B23: Intake from ventilated plant room and discharge via vertical flue. – Fig C1.2

The connection to the boiler is suitable for 150mm flue duct, for connection to an open flue (chimney) system . The resistance and maximum length of the flue system components is detailed in Figure C1.1

The following points should be noted:

a. Due to the high thermal efficiency of the boiler condensation in the flue will occur. It is strongly recommended that twin wall or insulated flue pipe is used on all external flue installations.

b. Care should be taken to ensure that the flue is installed such that any condensation is continuously drained. All flues should have a maximum slope of 2° upwards in the direction of the exhaust gas flow (no horizontal sections). All joints should be such that any condensation is directed back down the slope to an open drain connection in the flue. The drain pipe must be manufactured from a corrosion resistant material and be at least 15mm diameter. It must also have a fall of at least 2-3° (approx. 30-50mm per meter) and connect to a drain via a waste trap.

c. Boiler flue outlet sizes - A flue system designed with the same diameter as the boiler flue outlet may not provide satisfactory performance in all applications. Consideration must be given to the correct calculation of the required flue size. If in any doubt consult Hamworthy Heating Ltd who can supply a full flue design and installation service.

#### C1.2 Waste Gas Volume and Temperature.

It is recommended that the volume and temperature of the waste gases used for design of the flue system are as given in Table C1 above.



### **C1.3 Materials.**

Materials used for the flue system must be mechanically robust, resistant to internal and external corrosion, non-combustible and durable under the conditions to which they are likely to be subjected. Consideration must be given to avoid possible freezing of condense water traps and pipework

### **C1.4 Suction**

The flue system must be designed acknowledging that there is a positive pressure of generated by the boiler combustion fan available to the flue system. It is recommended that a draught stabiliser is fitted to the flue system where the draught is likely to become –ve at the boiler connection.

### **C1.5 Disconnection**

Provisions should be made for disconnection of the flue pipe for servicing. It is advisable that bends are fitted with removable covers for inspection and cleaning as appropriate.

**WARNING: THE FLUE SYSTEM MUST BE SELF SUPPORTING AND NOT PRESENT A RISK TO PEOPLE IN OR AROUND THE BUILDING.**

### **C1.6 Flue Discharge**

The flue system must ensure safe and efficient operation of the boiler to which it is attached, protect the combustion process from wind effects and disperse the products of combustion to the external air. The flue must terminate in a freely exposed position and be so situated as to prevent the products of combustion entering any opening in a building. Where the flue diameter is less than 204mm (8") diameter a terminal must be fitted. Where the flue is of a larger size, consideration should be given to the fitting of a flue discharge terminal or grille to stop ingress of birds etc.

### **C1.7 Surface Temperatures**

Combustible materials in the vicinity of the boiler and flue shall not exceed 65°C during boiler operation. The flue shall not be closer than 50mm to any combustible material, except where it passes through such material with a non-combustible sleeve when the air gap may not be less than 25mm.

### **C1.8 Location**

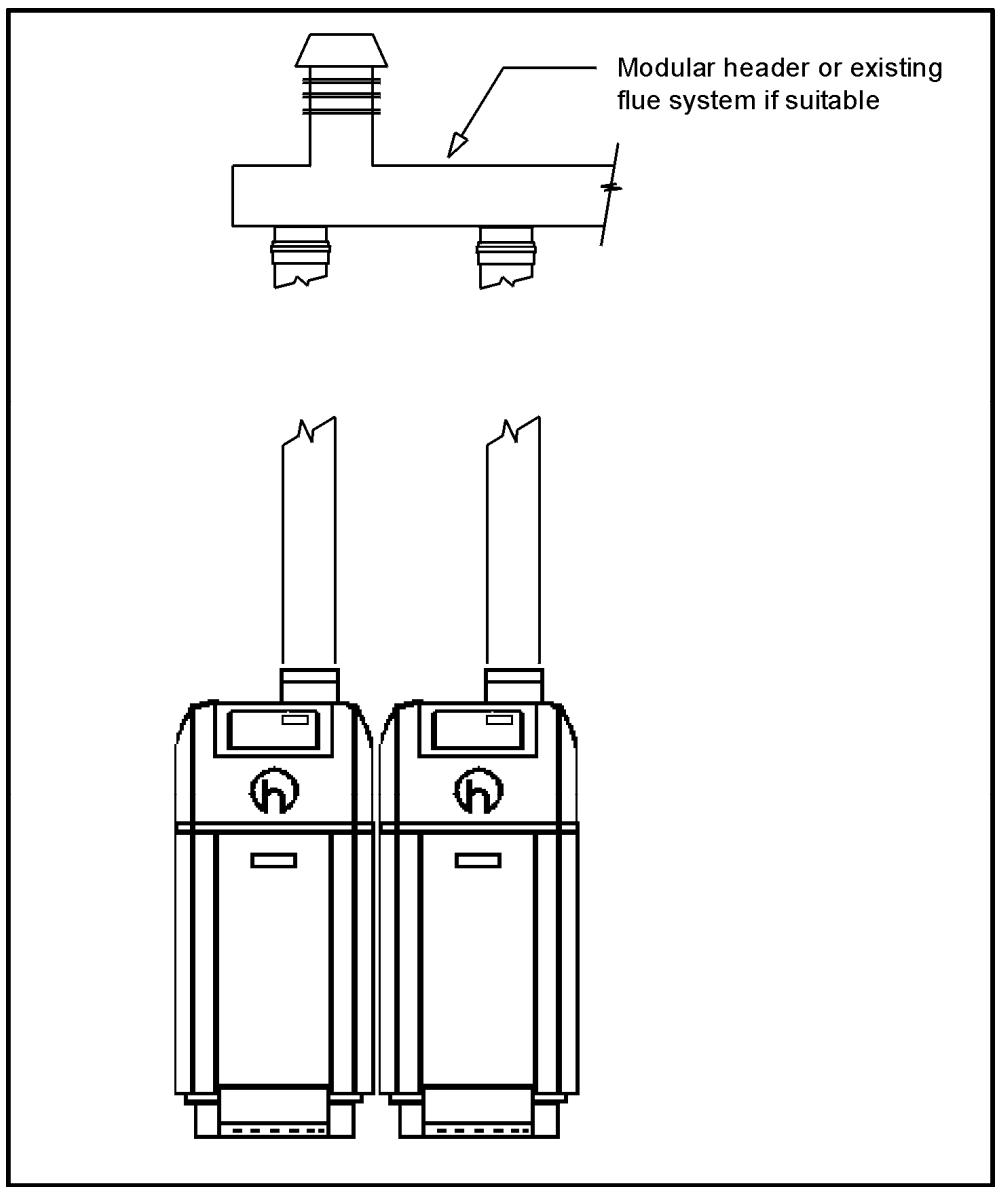
The flue system must not be placed or fitted where there is undue risk of accidental damage to the flue pipe or undue danger to persons in the vicinity. Check that the flue and chimney are clear from any obstruction. Purewell VariHeat he boilers are suitable for installation in a balanced compartment in accordance with the requirements of BS 6644. Consult Hamworthy Heating Technical Department for help or assistance if in doubt.

### **C1.9. Condensate Discharge**

Consideration should be given to possible freezing of condense water traps and pipework. This must be avoided at all times by routing pipework within the building, where possible. It is strongly recommended that on modular installations, the common header and chimney system must have separate drains for condensate disposal - **refer to section 4.5.**

Model				
Component	65 he	85 he	105 he	125 he
Straight tube $\varnothing$ 150mm maximum length (m)	149	88	69	47
45° bend $\varnothing$ 150mm Equivalent tube length (m)	2	2	2	2
90° bend $\varnothing$ 150mm Equivalent tube length (m)	2.2	2.2	2.3	2.3
Straight tube $\varnothing$ 100mm maximum length (m)	19	12	8	5
45° bend $\varnothing$ 100mm Equivalent tube length (m)	1.3	1.3	1.3	1.3
90° bend $\varnothing$ 100mm Equivalent tube length (m)	1.5	1.5	1.5	1.5

**Figure C1.1 - Flue Resistance**



**Figure C1.2 - Open (Natural Draught) B23 Flue System**

## **APPENDIX D - VENTILATION**

### **D1.1 Air Supply**

Detailed recommendations for air supply are given in BS 6644. The following notes are intended to give general guidance. In all cases there must be provision for an adequate supply of air for both combustion and general ventilation, in addition to that required for any other appliance.

Combustion air for the boiler is drawn through the rear of the boiler casing. The area **must** be kept open and free from blockage at all times.

### **D1.2 Air Supply by Natural Ventilation**

The boiler room must have, or be provided with, permanent air vents directly to the outside air, at high level and at low level. For an exposed boiler house, air vents should be fitted, preferably on all four sides, but at the least on two sides. Air vents should have negligible resistance and must not be sited in any position where they are likely to be easily blocked or flooded or in any position adjacent to an extraction system which is carrying flammable vapour. Grilles or louvres must be so designed that high velocity air streams do not occur within the space housing the boiler.

The air supplied for boiler house ventilation shall be such that the maximum temperatures within the boiler house shall be as follows;

- 1) At floor level (or 100mm above floor level) = 25°C
- 2) At mid-level (1.5m above floor level) = 32°C
- 3) At ceiling level (or 100mm below ceiling level) = 40°C.

Where both low and high level openings are used, the grilles shall have a total minimum free area of:

- Low level (inlet) - 4.0 cm<sup>2</sup> per kilowatt of total rated net heat input.
- High level (output) - 2.0 cm<sup>2</sup> per kilowatt of total rated net heat input.

If the boilers are to operate during the summer months for 75% of the time a further 1 cm<sup>2</sup> or for 100% of the time a further 2 cm<sup>2</sup> should be added per kW to both high & low openings.

### **D1.3 Air Supply by Mechanical Ventilation**

Air supplied to the boiler room by Mechanical means should be as follows:

- 1) Mechanical ventilation must be interlocked with the boilers to prevent operation in the event of ventilation fan failure
- 2) Mechanical inlet and mechanical extract can be utilised providing the design extraction rate does not exceed one third of the design inlet rate.
- 3) Mechanical extract ventilation with natural inlet ventilation **MUST NOT** be used.

For Mechanical ventilation systems an automatic control should be provided to cut off the gas supply to the boiler, in the event of failure of air flow in either inlet or extract fans.

**Figure D1 Mechanical Ventilation Flow Rates**

Boilers Without Draught Diverters	Flow rate per kW total rated heat input (net)	
	Inlet air (Combustion ventilation)	Difference between inlet and extract air (Inlet minus extract ventilation)
	m <sup>3</sup> /h	m <sup>3</sup> /h
	2.6	1.35 +/- 0.18

## APPENDIX E - WATER DATA

WATER DATA						
Model			65he	85he	105he	125he
Water Connections (Flow & Return)			R2" male			
Maximum Water Pressure	-	bar g	7			
Water Content (not including headers)	-	litres	6	6	9	9
System Design Flow Rate @ 11°C ΔT Rise	-	litre/s	1.4	1.9	2.3	2.7
Minimum Flow Rate @ 15°C ΔT Rise	-	litre/s	1.0	1.4	1.7	2.0
Waterside Pressure Loss @ 11°C ΔT Rise	-	mbar	50	80	192	270
Waterside Pressure Loss @ 15°C ΔT Rise	-	mbar	28	47	98	149

**Figure E1 - Water Data**

### E1.1 Water Circulation System

The Purewell VariHeat boiler has a low water content and the requirements of minimum water flow are given in the above table. Recommendations for the water circulation system are given in BS 6644.

The following details are of particular importance for the correct installation of the water circulation system:

- 1) In a combined central heating and hot water system the hot water storage vessel must be of the indirect cylinder or calorifier type. The hot water storage vessel should be insulated, preferably with not less than 75mm (3") thick mineral fibre, or its thermal equivalent.
- 2) Circulating pipework not forming part of the useful heating surface should be insulated to help prevent heat loss and possible freezing, particularly where pipes are run through roof spaces and ventilated cavities. Cisterns situated in areas which may be exposed to freezing conditions should also be insulated. Furthermore, insulation exposed to the weather should be rendered waterproof.
- 3) Drain valves must be located in accessible positions which permit the draining of the whole system, including the boiler and hot water storage vessel.
- 4) Each boiler module has R2" male flow (indicated with a red spot) and return (indicated with a blue spot) connections. Boilers should be connected by flow and return headers. Headers should be connected to the system in a 'reverse / return' arrangement (the water flow in each header is in the same direction) to ensure equal flow in each module, or with a 'single pipe header system'. Figure E1.2 on the following page show typical layouts.
- 5) Ideally, individual valves should be fitted to each module to enable isolation from the system, however, the arrangement must comply with the requirements of BS 6644.

### E1.2 Minimum System Water Pressure

To comply with guidance note **PM5 (Health and Safety Executive)**, the minimum pressure requirements at the boiler are given below as examples:-

- 1) Single installed boiler running at 82°C flow temperature. Minimum head required is not less than 2.0 metres or 0.2 bar.
- 2) Single installed boiler running at 90°C flow temperature. Minimum head required = 3.0 metres or 0.30 bar.
- 3) Modular boiler installation running at 82°C flow temperature and 11°C rise across system. Minimum head required = 4.4 metres or 0.43 bar.
- 4) Modular boiler installation running at 82°C flow temperature and 15°C rise across system. Minimum head required = 6.5 metres or 0.64 bar.

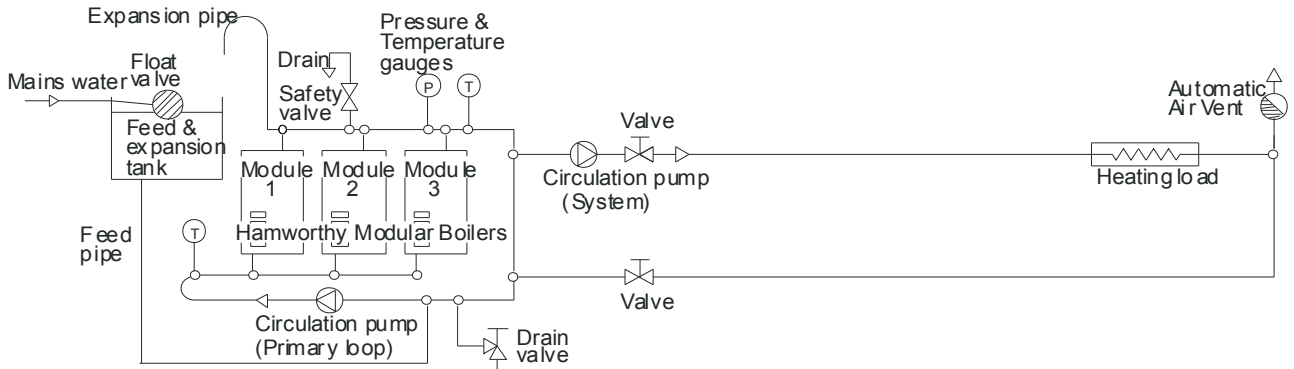
### E1.3 Pressure Relief Valve (Safety Valve)

The most important single safety device fitted to a boiler is its safety valve. Each boiler module is provided with a capped R1" stub pipe for the fitting of a safety valve (not supplied). BS 6644 provides comprehensive information for the selection and location of safety valves and attention is drawn to the higher capacity requirements of safety valves for pressurised hot water systems.

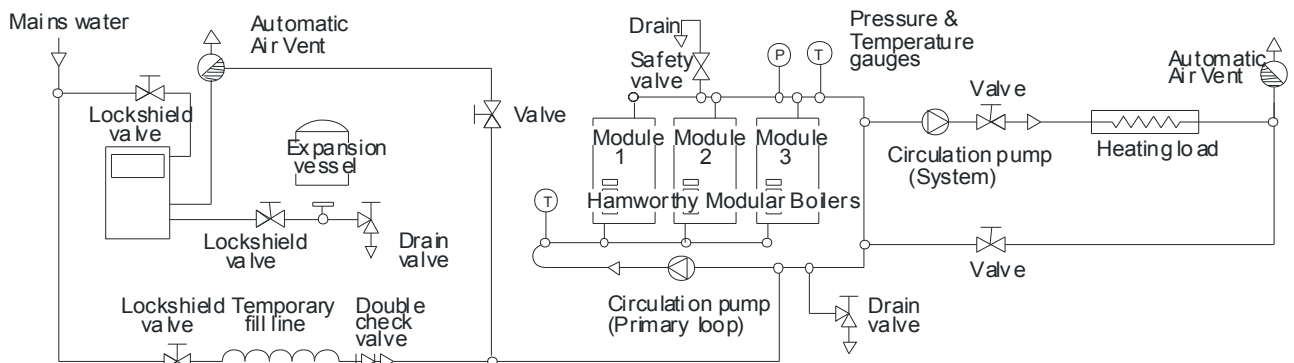
Boiler Output	Feed mm	Vent mm
60 - 150kW	25	32
150 - 300 kW	32	38
300 - 600 kW	38	50

**Figure E1.1 Cold Feed and Vent Pipe Sizes**

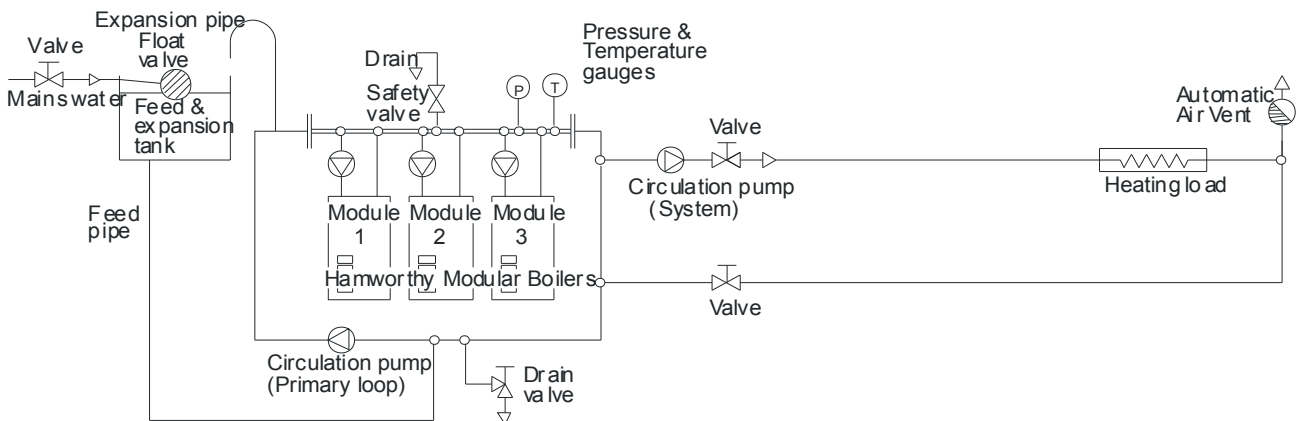
**Figure E1.2 - Typical Piping Layouts**



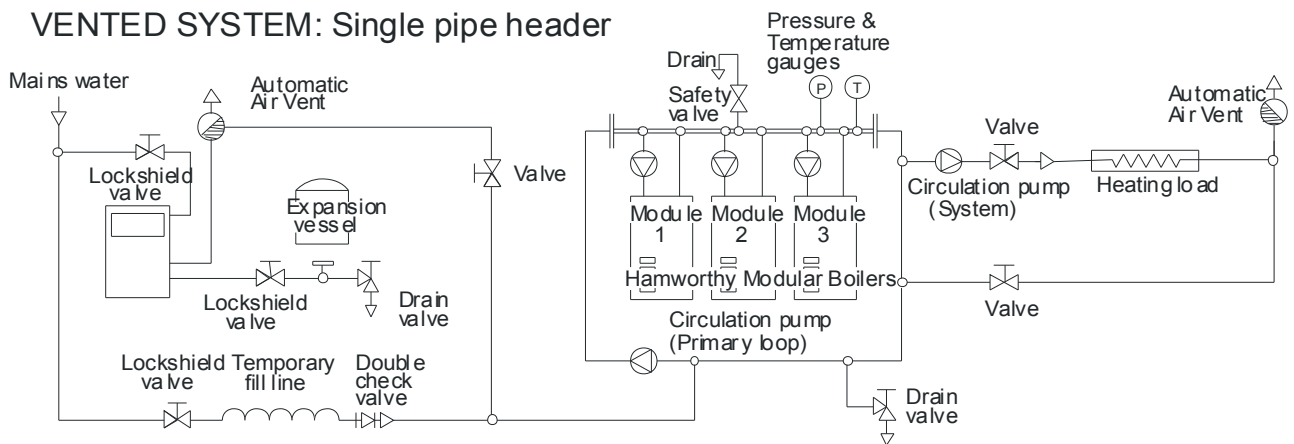
**VENTED SYSTEM: Primary loop, Hamworthy recommended system.**



**UNVENTED SYSTEM: Primary loop, Hamworthy recommended system.**



**VENTED SYSTEM: Single pipe header**



**UNVENTED SYSTEM: Single pipe header**

#### **E1.4 Open Vent and Cold Feed Pipe.**

Every boiler or group of boilers should have an open vent pipe and cold feed pipe installed between the boiler and the first water isolating valve. The minimum bore (mm) of these pipes per installation is shown in the table. The vent pipe must rise continually, any valve fitted between a boiler and the open vent pipe for maintenance purposes shall be of the 3 way type such that when closed to the vent pipe the boiler will be open to atmosphere. The vent pipe shall be protected against freezing where this might occur. See BS 6644 for detailed information on Open Vent and Cold Feed Pipes.

#### **E1.5 Altitude Gauge (Water Pressure Gauge)**

Every boiler or group of boilers should be provided with an altitude gauge complete with isolating valve. See Figure E1.2 for typical position.

#### **E1.6 Thermometer**

A thermometer complete with pocket should be fitted in the pipework to indicate water flow temperature. See Figure E1.2 for typical position.

#### **E1.7 Drain Valves**

Each boiler is fitted with a 15mm NB drain valve in the boiler return to drain the boiler only. The heating system in total should have drain valves as recommended by BS 6644. See Figure E1.2 for typical position.

#### **E1.8 Circulating Pump**

One or more circulating pumps will be required to circulate water around the boilers and heating system. The pump should be sited to facilitate servicing. It is important that when Purewell VariHeat boilers are used to replace boilers on an existing system, the pumps should be checked for performance against the new boiler waterside pressure loss to ensure that the minimum flow rate can be obtained. It is also important that the existing system be flushed through twice to remove any loose matter which may have accumulated. If in any doubt regarding the cleanliness of the system, a coarse filter should be fitted in the return pipework to the boilers.

If boiler / system pump(s) are not controlled by the boiler, a pump overrun (not Hamworthy Heating Ltd supply) should be fitted which must run for a minimum of 5 minutes on shutdown of the last boiler.

#### **E1.9 Minimum Water Flow Rates**

Minimum water flow rates are shown in table at beginning of Appendix E. These flow rates should be maintained through the boiler at all times whilst the boiler is firing. If the water flow rate is allowed to fall below the minimum the boiler heat exchanger could fail due to the resultant scale formation. Particular attention should be paid to the restriction of external flow circuits during periods of low heat demand.

#### **E1.10 Waterside Pressure Drop**

The waterside hydraulic resistance (Pressure drop) is given in table E1 at beginning of Appendix E.

#### **E1.11 Water Flow Controls**

Any external mixing valve / shunt pump or similar controls MUST always ensure that the minimum water flow rate as given in table at beginning of Appendix E is maintained. If there is any doubt relating to site flow conditions it is suggested that a flow switch is fitted. The flow switch should be connected such that the boiler will shut down if insufficient flow occurs.

#### **E1.12 Frost Protection**

Consideration should be given to fitting a frost thermostat set at approximately 4°C

#### **E1.13 Unvented Systems**

Refer to Figure E1.2 for typical layout of an unvented (Pressurised) Hot Water System. For system design refer to BS 7074 Part 2. In order to correctly size a pressurisation unit for any heating system the following parameters

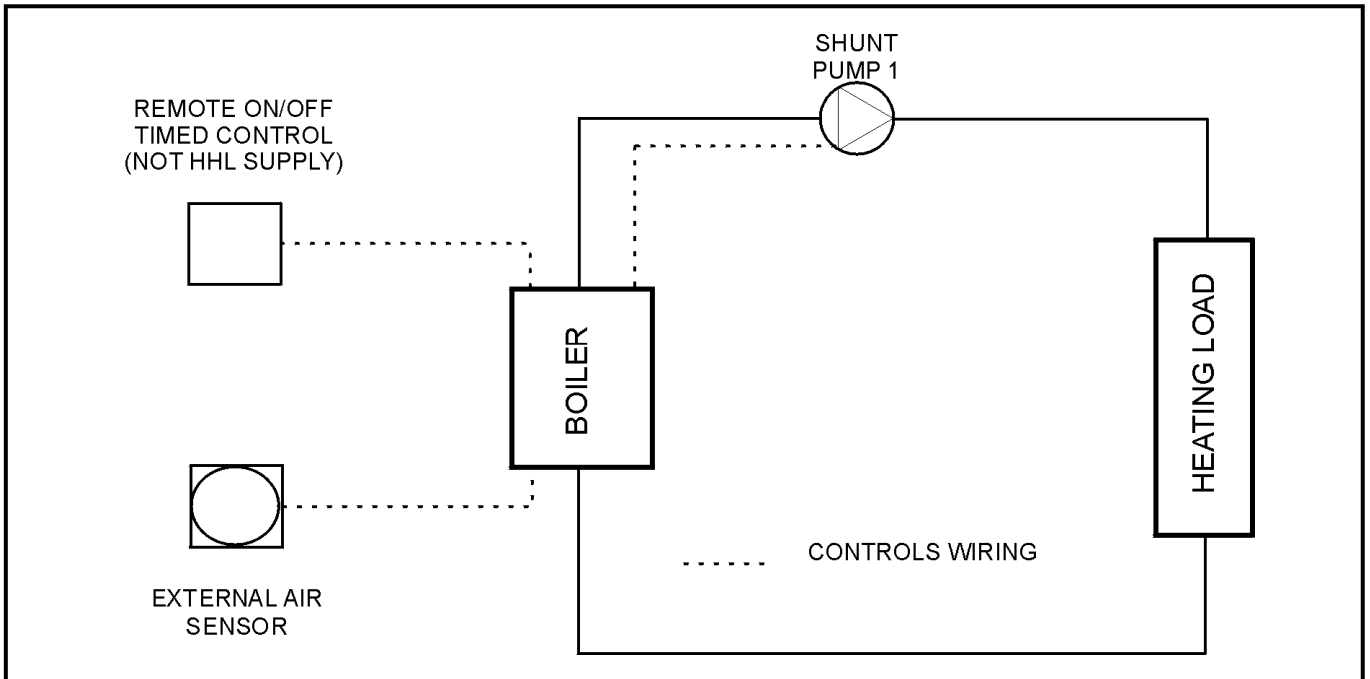
are required.

- 1) Static height of highest component in system (metres)
- 2) System volume. If this is not known, a general rule of thumb of 10litres/kW of installed boiler power can be used.
- 3) Maximum flow temperature (°C)
- 4) Maximum system hot working pressure, generally given in bar gauge.

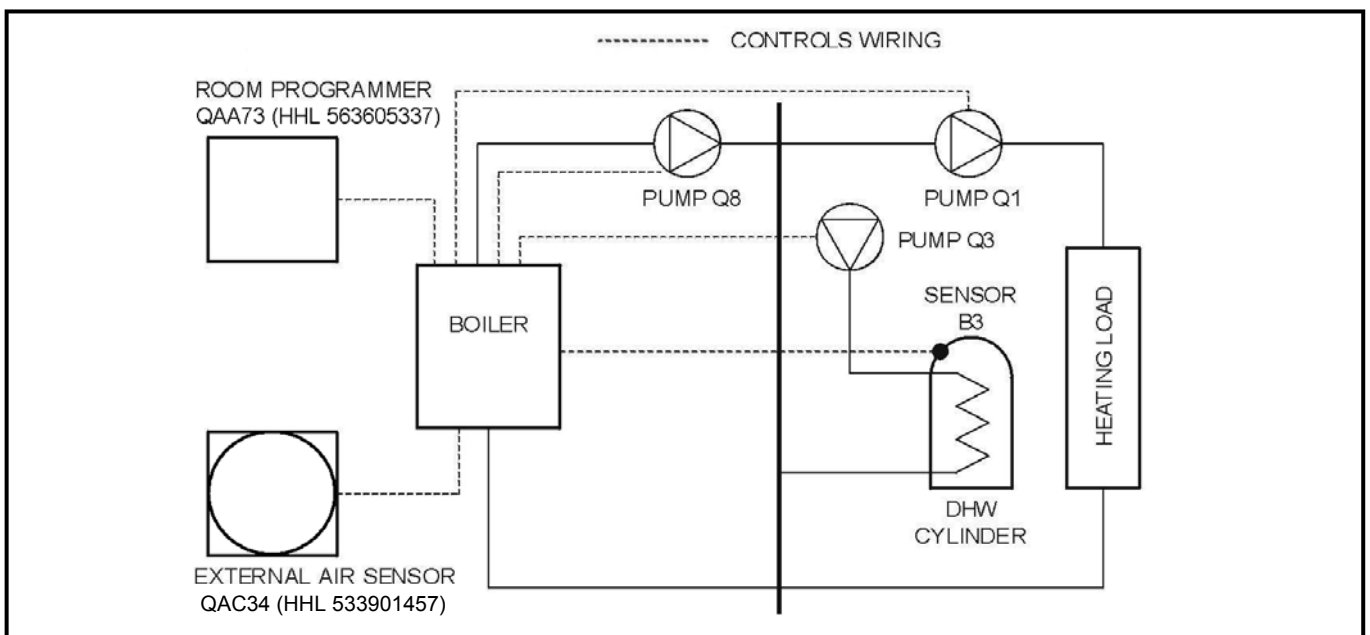
From the parameters given, Hamworthy Heating can size the pressurisation unit and also the expansion vessel required.

Care must be taken in sizing expansion vessels to ensure maximum acceptance factors are not exceeded. Normally manufacturers of vessels impose a limit of 0.5. This value must not be exceeded at any time during the operation of the boiler, this includes the over pressure condition should a safety valve lift.

Consideration should also be given to sizing of the safety valve(s) in the system. Refer to BS 6644: Part 1 for further information and to BS 6880: Part 1 for design considerations.



**Figure E 1.3.1 - Schematic for Single Boiler System**



**Figure E 1.3.2 - Schematic for Single Boiler, Primary Circuit System**

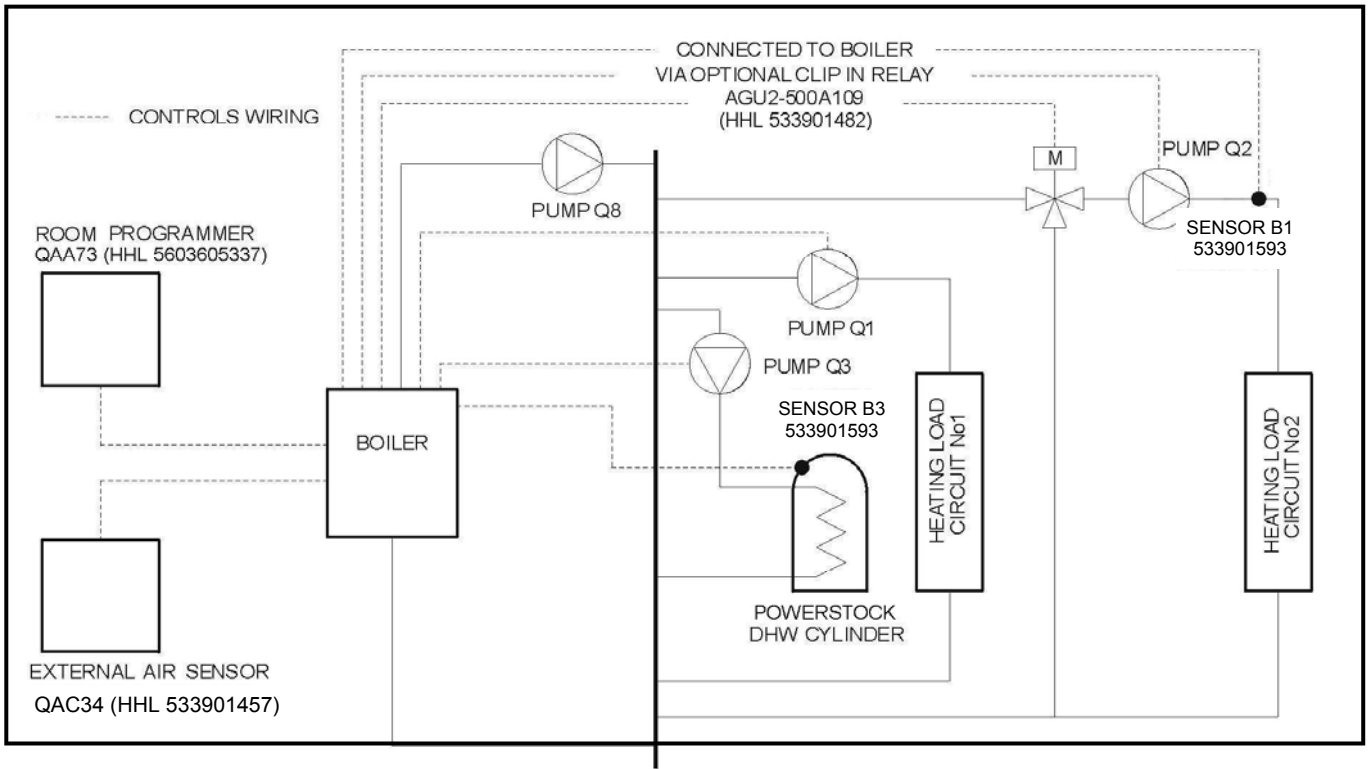


Figure E 1.3.3 - Schematic for Single Boiler (External 0-10V), Multi Circuit System

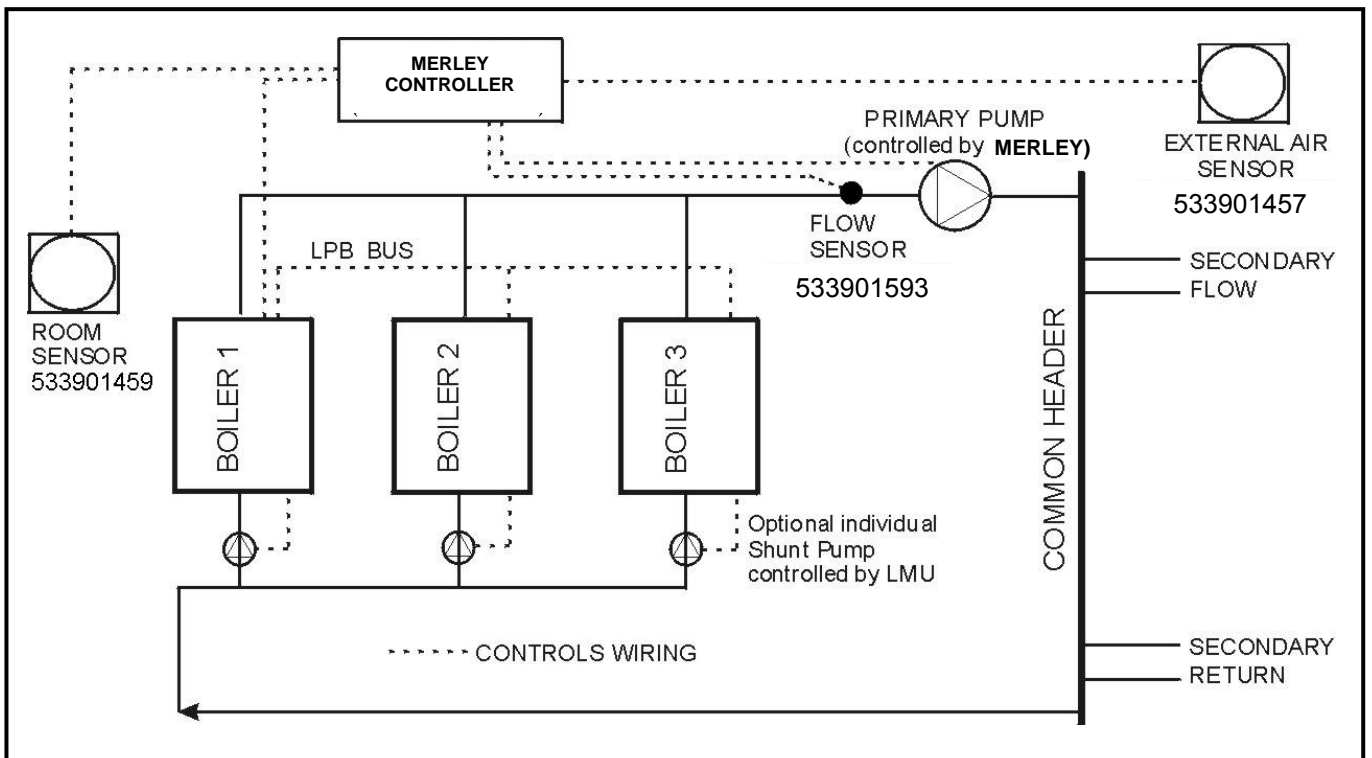


Figure E 1.3.4 - Schematic for Multiple Boiler (Cascade), Primary Circuit System



**USEFUL USER INFORMATION**

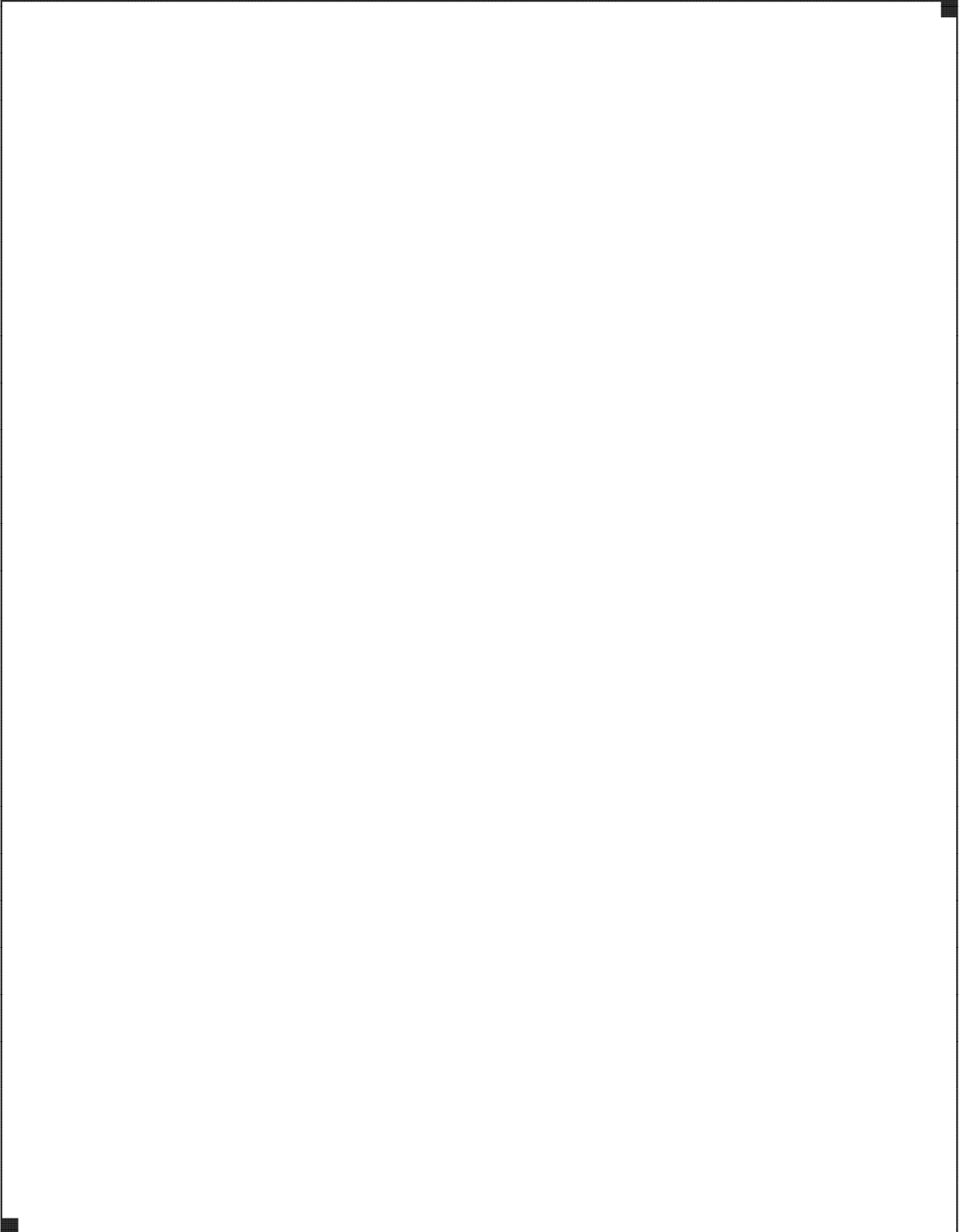
<b>INSTALLER</b>	<b>SITE ADDRESS</b>

<b>BOILER TYPE</b>	<b>BOILER SIZE(S)</b>	<b>UNIT NO(S).</b>	<b>SERIAL NO(S).</b>	<b>FLUE</b>

**NOTES**

NOTES:

# Notes



# Hamworthy Heating Accredited Agents

## **North West England (Sales & Service)**

Gillies Modular Services  
210-218 New Chester Road, Birkenhead, Merseyside L41 9BG  
tel: **0151 666 1030** fax: **0151 647 8101**

## **Southern Ireland (Sales & Service)**

HEVAC Limited  
Naas Road, Dublin 12, Ireland  
tel: **00 353 141 91919** fax: **00 353 145 84806**

## **Northern Ireland (Sales & Service)**

HVAC Supplies Limited  
Unit A6, Dargan Court, Dargan Crescent, Belfast BT3 9JP  
tel: **02890 747737** fax: **02890 741233**

## **Scotland (Sales & Service)**

McDowall Modular Services  
2 Penston Road, Glasgow, Scotland G33 4AG  
tel: **0141 336 8795** fax: **0141 771 9635**

## **North East England (Service)**

Allison Heating Products  
12 Sunnyside Lane, Cleadon Village, Sunderland SR6 7XB  
tel: **0191 536 8833** fax: **0191 536 9933**

# Hamworthy Heating Customer Service Centre

## **Sales**

tel: **0845 450 2865**

## **Technical Enquiries**

tel: **0845 450 2865**

## **Servicing**

tel: **01202 662555**

## **Spares**

tel: **0845 450 2866**



## **Customer Service Centre**

Hamworthy Heating Limited,  
Fleets Corner, Poole,  
Dorset BH17 0HH

Telephone: **0845 450 2866**

Fax: **01202 662522**

Email: **[aftersales@hamworthy-heating.com](mailto:aftersales@hamworthy-heating.com)**

Website: **[www.hamworthy-heating.com](http://www.hamworthy-heating.com)**