



Hamworthy Trigon

ST1 Solar Pump Station

**Installation, Commissioning,
Operation & Service Instructions**

IMPORTANT NOTE

**THESE INSTRUCTIONS MUST BE READ
AND UNDERSTOOD BEFORE INSTALLING,
COMMISSIONING, OPERATING OR
SERVICING EQUIPMENT**



Heating *at work.*

Customer After Sales Services

Telephone: **01202 662555** E-mail: **service@hamworthy-heating.com** Fax: **01202 662522**

Technical Enquiries

To supplement the detailed technical brochures, technical advice on the application and use of products in the Hamworthy Heating range is available from our technical team in Poole and our accredited agents.

Site Assembly

Hamworthy offer a service of site assembly for many of our products where plant room access is restricted. Using our trained staff we offer a higher quality of build and assurance of a boiler built and tested by the manufacturer.

Commissioning

Commissioning of equipment by our own engineers, accredited agents or specialist sub-contractors will ensure the equipment is operating safely and efficiently.

Service Contracts

Regular routine servicing of equipment by Hamworthy service engineers inspects the safety and integrity of the plant, reducing the risk of failure and improving performance and efficiency. Service contracts enable you to plan and budget more efficiently.

Breakdown service, repair, replacement

Hamworthy provide a rapid response breakdown, repair or replacement service through head office at Poole and accredited agents throughout the UK.

Spare Parts

We offer a comprehensive range of spare parts, providing replacement parts for both current and discontinued products. Delivery options are available to suit you. Please refer to our website for more details.

Hamworthy Trigon
ST1 Solar Pump Station
**Installation, Commissioning,
Operation & Service Instructions**

**NOTE: THESE INSTRUCTIONS MUST BE READ AND UNDERSTOOD BEFORE
INSTALLING, COMMISSIONING, OPERATING OR SERVICING THIS EQUIPMENT.**

THE TRIGON ST1 SOLAR PUMP STATION COMPLIES WITH ALL RELEVANT EUROPEAN DIRECTIVES.

**PUBLICATION NO. 500001281
ISSUE 'A'
JUNE 2013**

HAMWORTHY TRIGON INSTALLATION AND OPERATION MANUAL

SOLAR PUMP STATION ST1

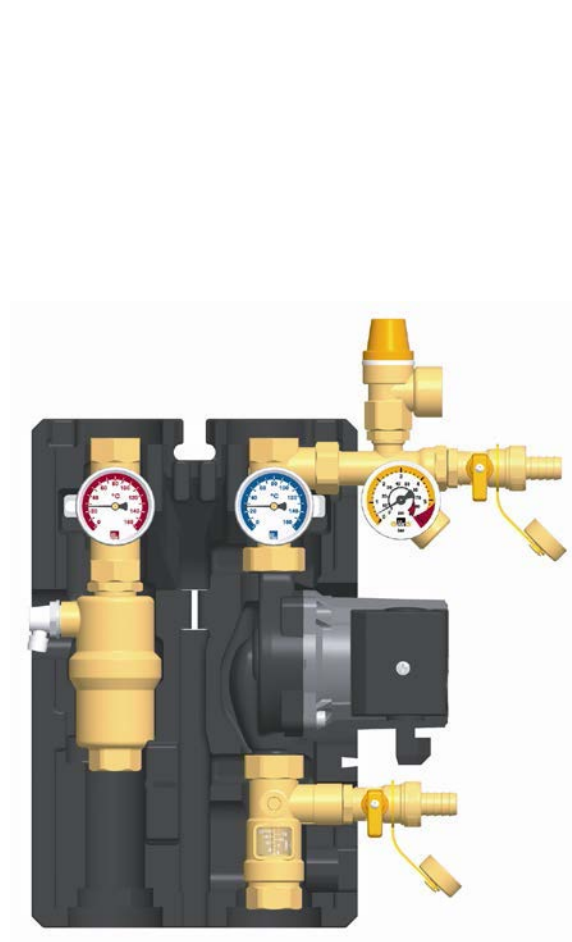

Customer Service Centre
Hamworthy Heating Limited
Fleets Corner, Poole,
Dorset BH17 0HH I

Item no. 0DNO0201

Translation of the original instructions

We reserve the right to make technical changes without notice!

Printed in Germany – Copyright by Hamworthy

Contents

1	General information	4
1.1	About these instructions	4
1.2	About this product	4
1.3	Designated use	5
2	Safety instructions	6
3	Assembly and installation [installer]	8
4	Commissioning [installer]	11
4.1	Flushing and filling the solar circuit.....	12
4.2	Preparations before flushing.....	14
4.3	Flushing and filling	14
4.4	Setting the solar installation (only for standard solar pumps).....	17
5	Maintenance [installer]	18
5.1	Draining the solar installation	18
5.2	Disassembly.....	18
6	Spare parts [installer]	19
6.1	ST1 Solar Pump Station.....	19
	Controller extension	20
7	Technical data	20
7.1	Pressure drop characteristics ST1 Solar Pump Station	21
8	Function check valves [installer]	22
9	Commissioning report.....	24

1 General information



Carefully read these instructions before installation and commissioning. Save these instructions in the vicinity of the installation for future reference.

1.1 About these instructions

These instructions describe the installation, commissioning, function and operation of the TRIGON ST1 Solar Pump Station. The chapters called [installer] are intended for installers only. For other components of the solar thermal system such as collectors, tanks, expansion vessels and controllers, please refer to the instructions for that component.

1.2 About this product

The station is a premounted fitting group checked for leakage used to circulate the solar fluid in the solar circuit. It is mounted on a wall bracket and fixed with clips. The solar station is optionally equipped with a controller. It contains important fittings and safety devices for the operation of the installation:

- Ball valves in the flow line (1.1) and return line (5.1)
- Check valves in the flow (1.1) and return ball valves (5.1)
- Thermometers in the flow (5.2) and return line (1.2)
- Pressure gauge to display the installation pressure (1.6)
- Flowmeter to display the flow rate (3.3)
- Ball valve to reduce the flow rate (3.1)
- Solar pressure relief valve (1.3)
- De-aerator to easily vent the solar circuit (4.2)
- Drain (3.2) and fill valves (1.4) with hose connectors

1.3 Designated use

The solar station may only be used as a pump station in the solar circuit taking into consideration the technical limit values indicated in these instructions. Due to its design the station must be mounted and operated as described in these instructions!

Improper usage excludes any liability claims.

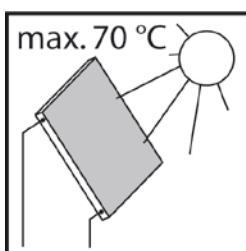
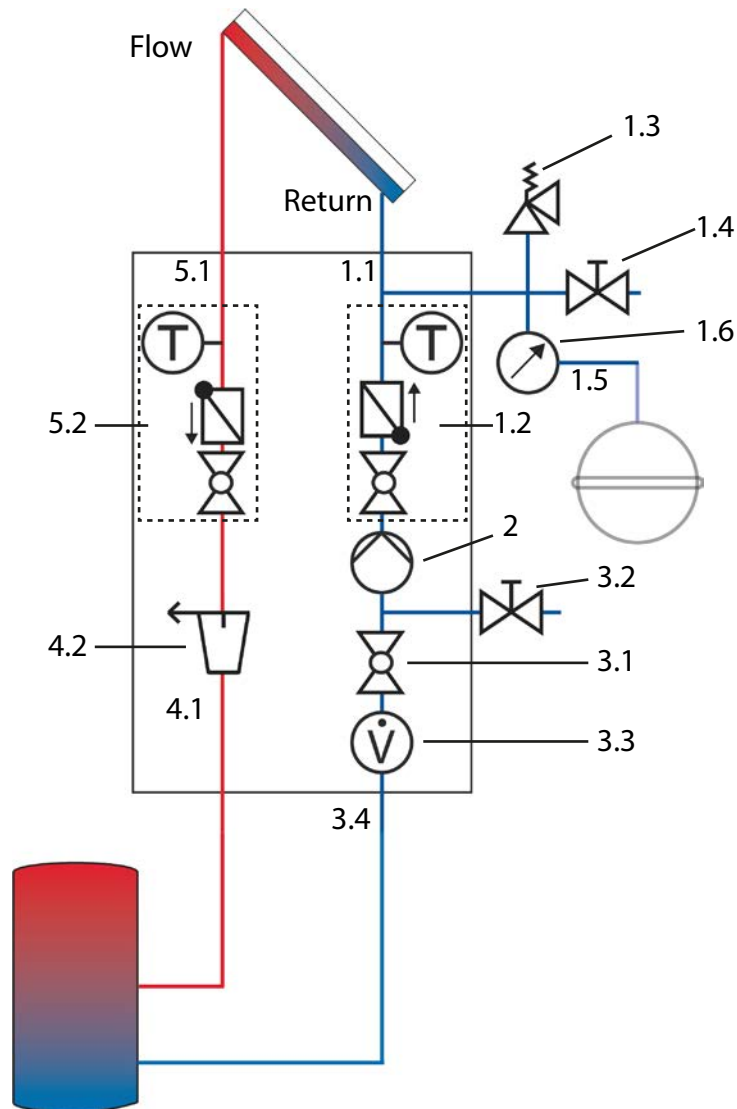



When the sun shines, the collector can become very hot. The solar fluid in the circuit can heat up to more than 100 °C.



Only flush and fill the solar circuit when the collector temperatures are below 70 °C.

2 Safety instructions

The installation and commissioning as well as the connection of electrical components require technical knowledge commensurate with a recognised vocational qualification as a fitter for plumbing, heating and air conditioning technology, or a profession requiring a comparable level of knowledge [installer]. The following must be observed during installation and commissioning:

- relevant local and national regulations
- accident prevention regulations of the professional association
- instructions and safety instructions mentioned in this manual
- use appropriate personal and protective equipment eg safety glasses, gloves, etc...

	 WARNING
	<p>Danger of scalding due to vapour escape!</p> <p>With pressure relief valves there is risk of scalding due to vapour escape. During installation, check the local conditions and if a discharge line must be connected to the safety group.</p> <ul style="list-style-type: none">➤ Observe the instructions regarding the pressure relief valve.➤ The pressures calculated by the installation planner for the expansion vessel and the operating pressure of the installation must be set.

	 CAUTION
	<p>Risk of burns!</p> <p>The valves, fittings and the pump may heat up to more than 100 °C during operation.</p> <ul style="list-style-type: none">➤ The shell must remain closed during operation.

 A schematic diagram of a pressure relief valve assembly. It shows a tank with a pressure relief valve on top. Two ball valves are located in the primary circuit leading to the valve. A warning symbol (a triangle with an exclamation mark) is overlaid on the diagram.	<p>CAUTION</p> <p>Personal injury and damage to property due to overpressure!</p> <p>By closing the two ball valves in the primary circuit you isolate the pressure relief valve from the heat exchanger. A rise in temperature in the storage tank will cause high pressures and could result in personal injury or damage to property!</p> <ul style="list-style-type: none">➤ Only close the ball valves for service and maintenance.
---	--

NOTICE

Material damage due to mineral oils!

Mineral oil products cause lasting damage to seals made of EPDM, whereby the sealant properties are lost. We do not assume liability nor provide warranty for damage to property resulting from sealants damaged in this way.

- It is imperative to avoid that EPDM gets in contact with substances containing mineral oils.
- Use a lubricant based on silicone or polyalkylene and free of mineral oils such as Unisilikon L250L and Syntheso Glep 1 of the Klüber company or a silicone spray.

3 Assembly and installation [installer]

NOTICE

Material damage due to high temperatures!

Install the pump station at a sufficient distance from the collector field, since the solar fluid may be very hot near the collector. It may be necessary to install an intermediate tank in order to protect the expansion vessel.



1. Remove the station from the packaging.
2. Remove the insulating front shell.



3. Copy the mounting holes of the solar station besides the thermometers to the mounting surface.
4. Drill the holes and mount the solar station to the wall with the enclosed wall plugs and screws.

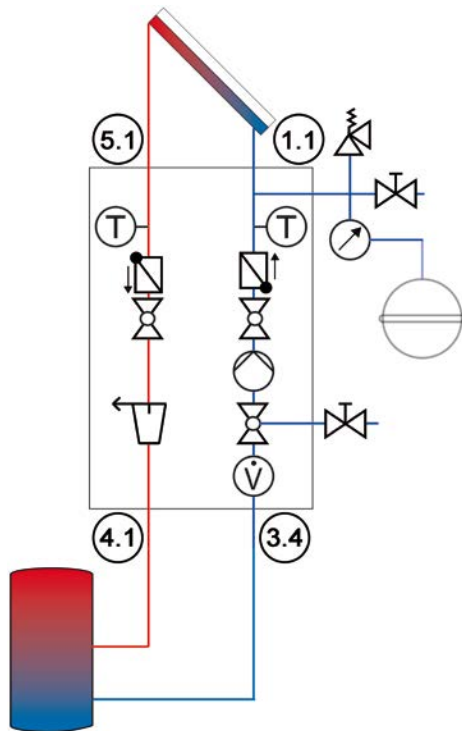

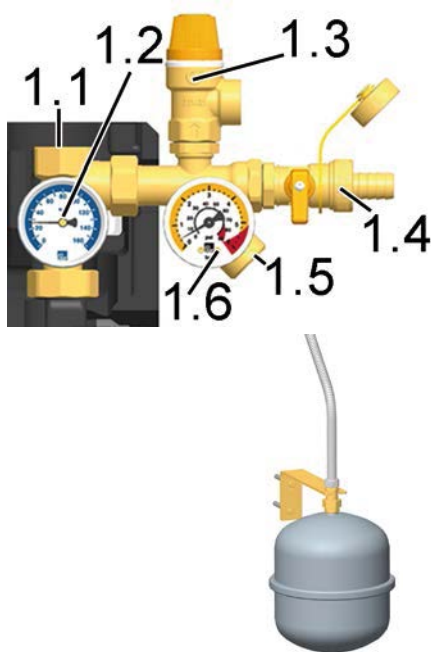

5. Connect the solar station to the installation:
 - 5.1 flow from the collector field
 - 1.1 return to the collector field
 - 4.1 flow to the storage tank
 - 3.4 return from the storage tank



Optionally available!

6. Connect the pipe for the expansion vessel below the pressure gauge [1.5] and fix the bracket for the expansion vessel.
7. Pressurise the expansion vessel as specified by the manufacturer and connect the expansion vessel. Observe the separate instructions regarding the expansion vessel!
8. Check all screw connections and tighten them if necessary.

	 WARNING
	<p>Risk to life and limb due to electric shock!</p> <ul style="list-style-type: none">➤ Prior to commencing electrical work on the controller, disconnect the mains plug from the mains➤ Only after completing all installation work, flushing and filling, plug the mains plug of the controller into a socket! This avoids an unintentional start of the motors.

9. Connect the pump and the sensors to the controller.

The assembly of the solar station is completed and you can put the station into operation.

4 Commissioning [installer]

Observe the following safety instructions regarding the commissioning of the station:

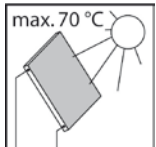
! WARNING	
	<p>Risk of burning and scalding!</p> <p>The fittings can heat up to more than 100 °C. Therefore, do not clean or fill the system with the collectors heated (intense sunshine). Please note that hot solar fluid can leak from the pressure relief valves in case of too high system pressure!</p>
	<p>During venting the solar fluid may escape as vapour and cause scalding!</p> <ul style="list-style-type: none"> ➤ Only flush and fill the installation when the collector temperatures are below 70 °C when wearing appropriate personal and protective equipment.

NOTICE

Risk of frost!

It often happens that the solar thermal system cannot be completely drained after flushing. Thus, there is risk of frost damage when flushing with water. Therefore, do only use the solar fluid used later to flush and fill the solar installation.

- Use a water and propylene glycol mixture with max. 40% of propylene glycol as a solar fluid.

NOTICE

Note regarding the commissioning sequence

When putting the system into operation, first fill the heating circuit and then the solar circuit. This guarantees that heat that may possibly be absorbed by the collectors during commissioning can be dissipated.

NOTICE

Note regarding the expansion vessel

To prevent that the dirt particles in the solar thermal system are flushed into the expansion vessel, some manufacturers recommend to disconnect the expansion vessel from the solar circuit before flushing and filling. Please observe the instructions of the manufacturer.

4.1 Flushing and filling the solar circuit

The fill and drain valves required to flush and fill are integrated in the solar station.

To flush the dirt particles out of the installation, only use flush and fill stations with fine filters.

Ball valve with integrated flow check valve (1.2 and 5.2)

(normal flow direction in the figure below: downwards)

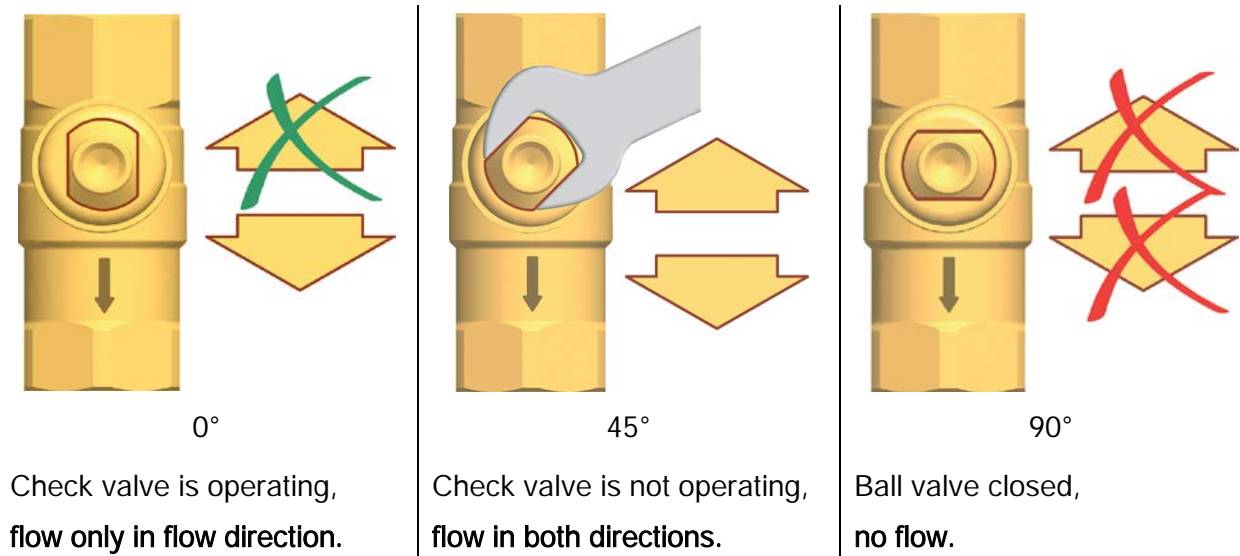

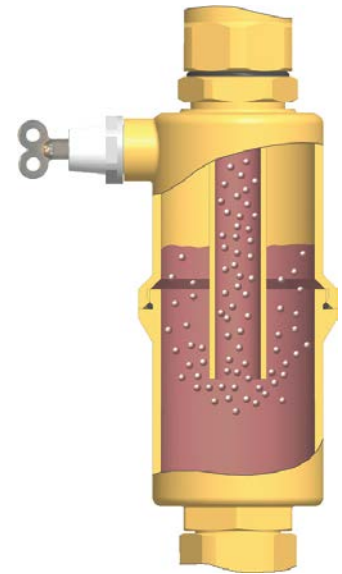

De-aerator

The de-aerator with manual vent valve is used to vent the solar installation. To ensure perfect deaeration of the solar circuit, the flow velocity must be at least 0.3 m/s in the flow line.



Pipe diameter [mm]		Flow rate at 0.3 m/s	
Ø outside	Ø inside	l/h	l/min
15	13	~ 143	~ 2.4
18	16	~ 217	~ 3.6
22	20	~ 339	~ 5.7

The air liberated from the solar fluid is collected in the upper part of the de-aerator and can be released at the vent plug [4.2].

	 WARNING
	<p>Danger of scalding due to vapour escape!</p> <p>The escaping fluid can have a temperature of more than 100 °C and cause scalding.</p> <ul style="list-style-type: none"> ➤ Carefully open the vent plug and close it again, as soon as medium escapes.

Venting the solar installation after commissioning

At the beginning, vent the solar installation daily and then weekly or monthly, depending on the vented air quantity. Thus, an optimum operation of the solar installation is ensured. Check the system pressure after venting and increase it to the specified operating pressure, if necessary.

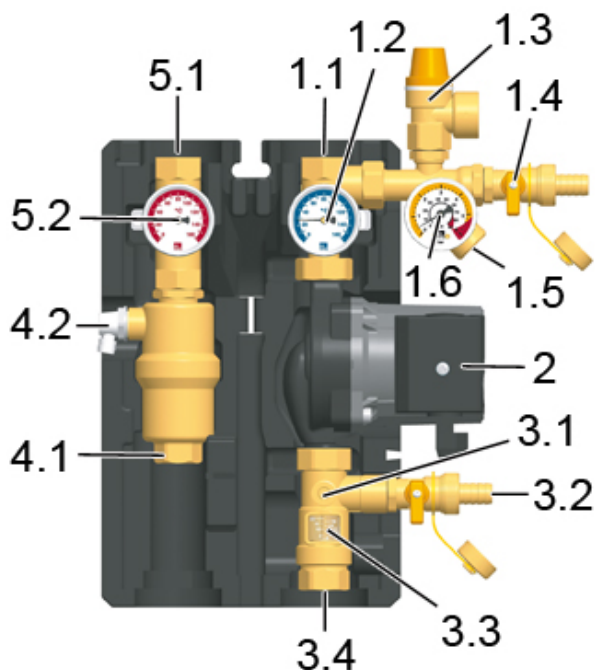

4.2 Preparations before flushing

The solar circuit is flushed in the direction of flow.

1. Disconnect the expansion vessel from the solar installation. Please observe the instructions of the manufacturer.
2. Turn the check valve in the flow ball valve [5.2] to operating position (0°, see page 12).
3. Close the return ball valve [1.2] (90°, see page 12).
4. The ball valve [3.1] must be open.
5. Connect the filling pump to the solar station:
 - Pressure hose to the fill valve [1.4]
 - Flush hose to the drain valve [3.2]

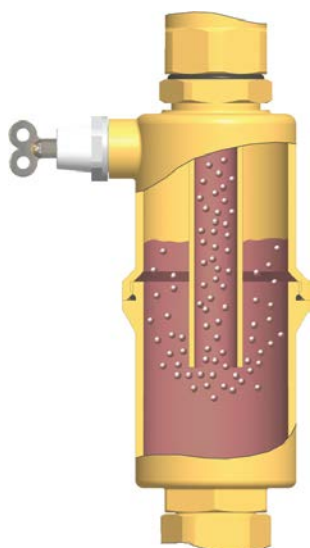

4.3 Flushing and filling

1. Open the fill and drain valves [1.4|3.2].
2. Put the flush and fill station into operation and flush the installation until clear solar fluid exits.

Vent the solar installation several times at the vent plug of the de-aerator [4.2] until the solar fluid exits without bubbles (see page 13).

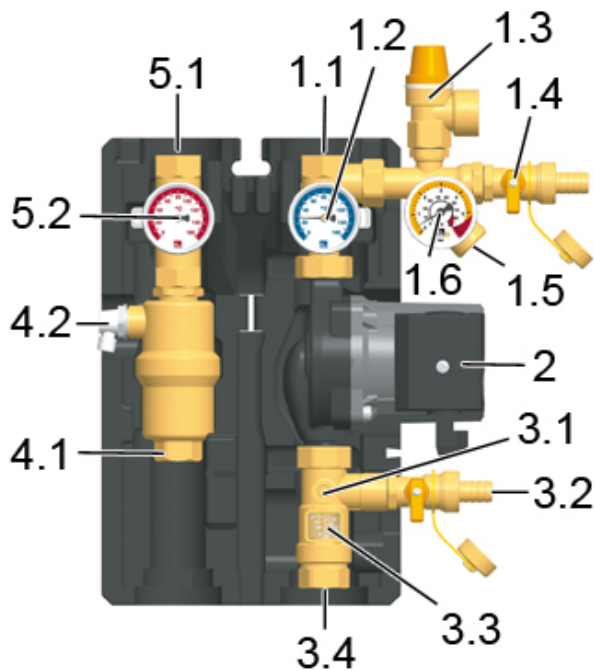



3. To vent the pump stroke, slowly open the return ball valve [1.2] (0°, see page 12).
4. Close the drain valve [3.2] with the filling pump running and increase the system pressure to max. 5 bars. The system pressure can be read on the pressure gauge. Close the fill valve [1.4] and switch off the pump of the flush and fill station.



Consider the pressure relief valve (6 bars)!

5. Check the pressure gauge to see whether the system pressure reduces and eliminate leaks where necessary.
6. Reduce the pressure at the drain valve [3.2] to the operating pressure.
7. Connect the expansion vessel to the solar circuit and set the operating pressure of the solar system by means of the flush and fill station (for the required operating pressure, see instructions of the expansion vessel).
8. Close the fill and drain valves [1.4][3.2].
9. Turn the check valve in the return ball valve [1.2] to operating position (0°, see page 12).

	 WARNING
<p>Risk to life and limb due to electric shock!</p> <ul style="list-style-type: none"> ➤ Check if the sensors and the pumps are properly connected to the controller and if the controller housing is closed. Only then should the mains plug of the controller be plugged into a socket. 	

10. Connect the optional controller to the mains and set the solar circuit pump in the manual mode to Max. according to the controller instructions. Let the solar circuit pump run at maximum rotation speed for at least 15 minutes.

Meanwhile vent the solar installation several times at the vent plug of the de-aerator until the solar fluid exits without bubbles (see page 12).

If necessary, increase the system pressure to the

11. Remove the hoses of the flush and fill station and screw the sealing caps onto the fill and drain valves.

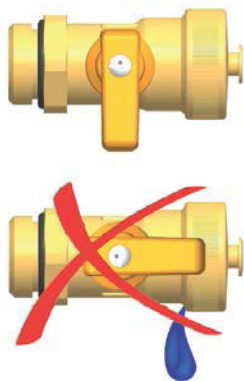

The sealing caps only serve to protect the valves against dirt. They are not designed to take up high system pressures. The ball valves must be closed.

12. Only for standard solar pumps:

Continue at point "4.4 Setting the solar installation" only for PWM pumps:

Mount the insulating front shell. Switch the controller to automatic mode (see controller instructions).

4.4 Setting the solar installation (only for standard solar pumps)

Observe the specifications of the collector manufacturer for the correct adjustment of the flow rate.

Reading edge =
Round edge of the float
Example:
 about 4 l/min

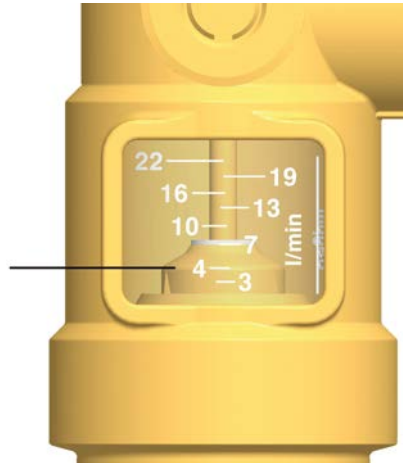

Scale DN 20:

3 – 22 l/min

Three speed solar pump

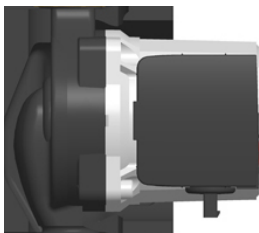

Optional controllers:

DeltaSol BS/2 (Standard controller)

DelatSol M (Advanced controller)

1. Set the pump P1 to Max. in the manual mode of the controller to set the maximum flow rate. The controller sets the corresponding rotation speed. If necessary, the flow rate can be adjusted at the ball valve [3.1].
2. Mount the insulating front shell to the station.
3. Switch the controller to automatic mode (see controller instructions).

The commissioning of the solar installation is now complete. Please fill in completely the commissioning report on page 25.

5 Maintenance [installer]

5.1 Draining the solar installation

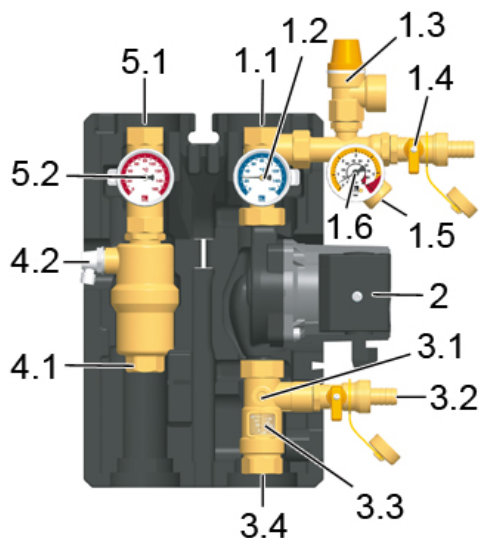

1. Switch off the controller and make sure that a restart is not possible.
2. Open the check valves in the flow and return ball valve [5.2|1.2], by turning them to a 45° position (45°, see page 12).
3. Connect a heat-resistant hose to the lowest drain valve of the solar installation (or to drain valve [3.2]). Make sure that the solar fluid is collected in a heat-resistant container.

 WARNING	<p>Danger of scalding due to hot solar fluid!</p> <p>The escaping fluid may be very hot.</p> <ul style="list-style-type: none"> ➤ Place and fix the heat-resistant collecting container so that people standing nearby are not endangered when the solar installation is being emptied.
---	---



4. Open the drain valve at the lowest point of the solar thermal system.
5. To accelerate draining of the solar circuit, you can open the bleeding device, if present, at the highest point of the solar thermal system.
6. Dispose of the solar fluid observing the local regulations.

5.2 Disassembly



1. Drain the solar thermal installation as described above.
2. Disconnect the pipe joints with the solar thermal system.
3. To remove the solar station from the mounting plate, pull the clips to the side using a screwdriver.
4. Pull out the station towards the front.

6 Spare parts [installer]

In case of a complaint, please send us the completely filled commissioning report on page 25.

6.1 ST1 Solar Pump Station

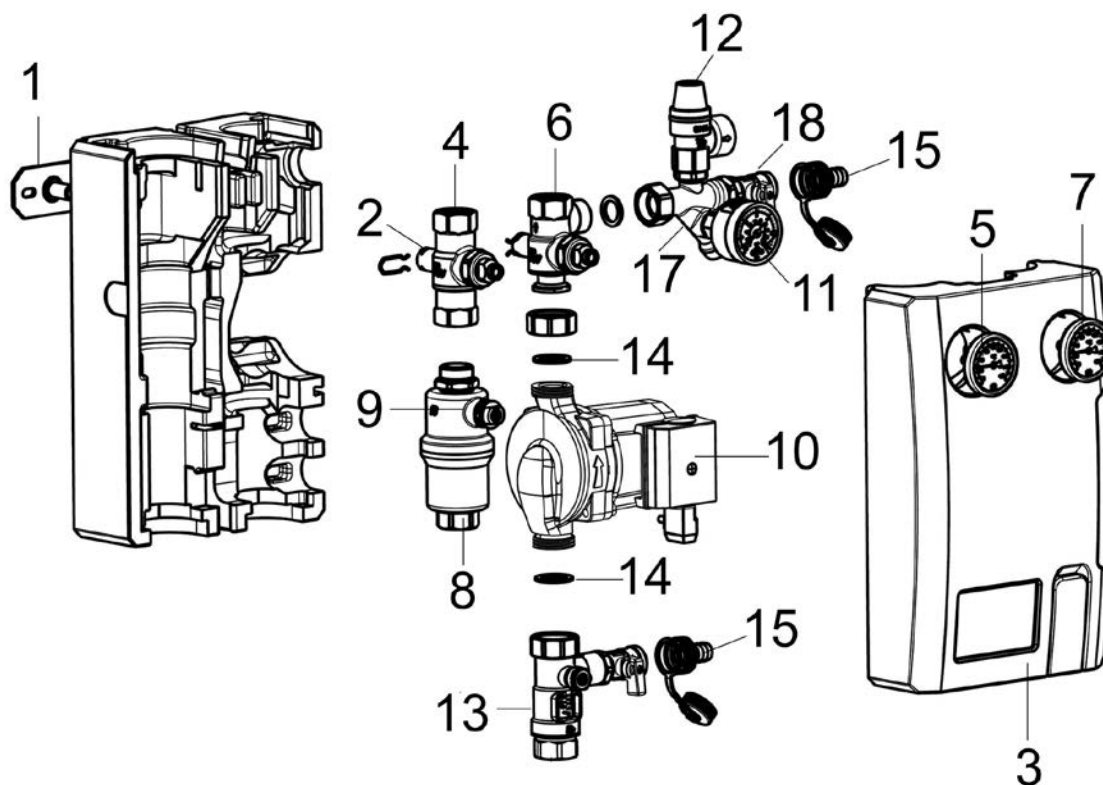

Spare parts: ST1 Solar Pump Station		
Position	Designation	HHL Part No.
1	Wall bracket	073336
2	Fixation clip (x 5)	073071
3	Front and back insulating shell made of EPP	073786
4	Ball valve with check valve, return from collector	073085
5	Thermometer, return from collector (red)	073787
6	Ball valve with check valve, flow towards collector	073072
7	Thermometer, flow towards collector (blue)	073788
8	De-aerator	073344
9	Vent plug	073789
10	Pump Wilo Star-ST 15/7 ECO-3	073068
11	Pressure gauge 0-6 bars	073790
12	Solar pressure relief valve 6 bars F 1/2"	073404
13	Flowmeter 3-22 l/min ST1	073792
14	Sealing set ST1	073347
15	Drain connection	073346
16	Cable for pump	073348
17	Counter cross	n.c.
18	Fill and drain valve	n.c.

7 Technical data

Dimensions		ST1 Solar Pump Station
Height (with controller extension)		560 mm
Height (without controller extension)		383 mm
Width (with insulation)		334 mm
Depth (with insulation)		150 mm
Centre distance flow/return		100 mm
Pipe connections		¾" internal thread
Connection for expansion vessel		¾" external thread, flat sealing
Outlet pressure relief valve		¾" internal thread
Operating data		
Max. admissible pressure		PN 10
Max. operating temperature		120 °C
Max. short-time temperature		160 °C, < 15 minutes
Max. propylene glycol content		40 %
Equipment		
Pressure relief valve		6 bars
Pressure gauge		0 – 6 bars
Check valves		2 x 200 mm wc, can be opened
Flowmeter		3-22 l/min
Material		
Valves and fittings		Brass
Gaskets		EPDM
Check valves		Brass
Insulation		EPP, $\lambda = 0.041 \text{ W/(m K)}$

7.1 Pressure drop characteristics ST1 Solar Pump Station

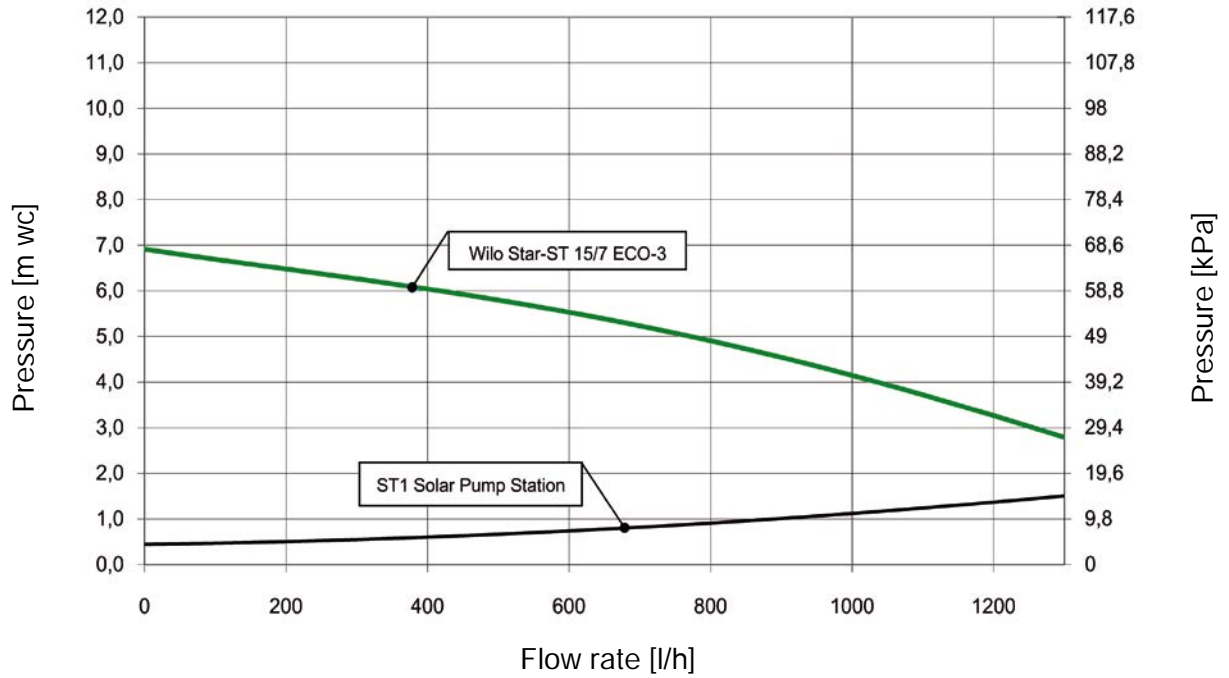

8 Function check valves [installer]

Within their application range, the check valves in this station prevent unwanted gravity circulation. The efficiency of the check valves depends on:

- the installation height
- the temperature difference between the storage tank and the collector
- the type of heat transfer medium

In the diagram below you can see whether the check valves integrated in the station are sufficient. If the check valves are not sufficient, you need to install additional components to prevent gravity circulation. You can mount components such as syphons ("heat traps"), 2-way valves (zone valves) or additional check valves.

Example:

- The station comprises two check valves (2 x 200 mm wc = **400 mm wc**).
- You use a mixture of water and 40% of propylene glycol as a **solar fluid**.
- The installation height between the collector and the storage tank is **10 m**.

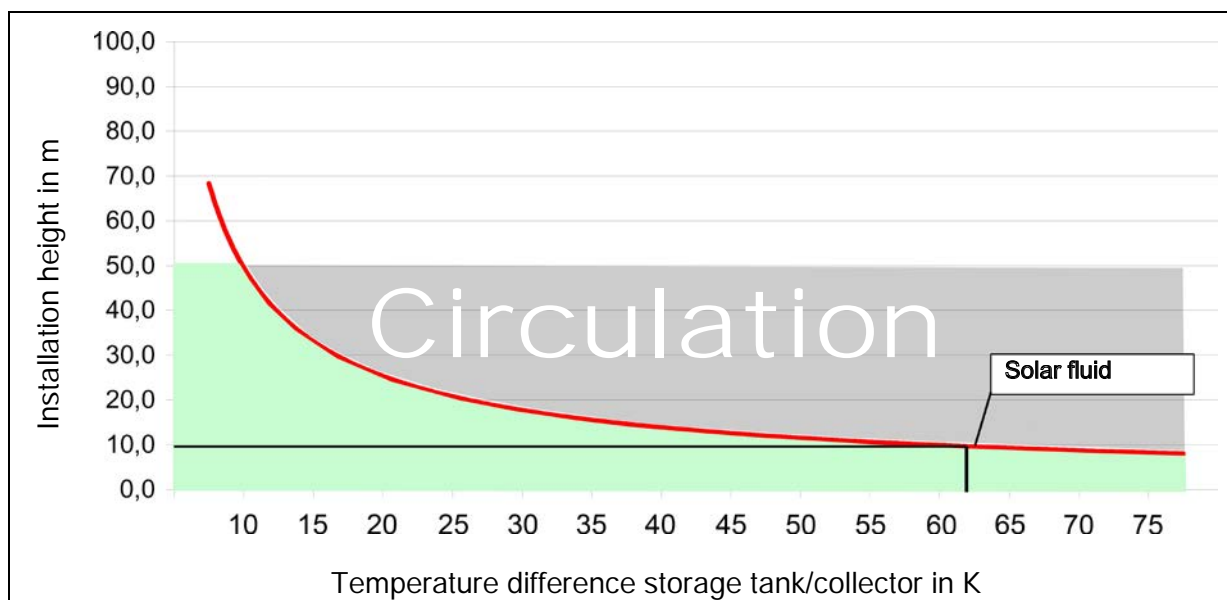

Result:

The check valves prevent gravity circulation up to a temperature difference of **about 62 K**. If the temperature difference between the collector and the tank is larger, the difference in density of the solar fluid will be so large, that the check valves are pushed open.



Do you need to know it exactly?

The density of the solar fluid decreases with rising temperature. In high installations with large temperature differences, the difference in density will cause gravity circulation. This circulation can cool down the storage tank.

Calculation example: $\Delta p \equiv \Delta \rho * g * h$

Collector temperature: 5 °C → Density solar fluid $\rho_1 = 1042 \text{ kg/m}^3$

Storage tank temperature: 67 °C → Density solar fluid $\rho_2 = 1002.5 \text{ kg/m}^3$

$$\Delta \rho = \rho_1 - \rho_2 = 39.5 \text{ kg/m}^3$$

$$g = 9.81 \text{ m/s}^2$$

Installation height $h = 10 \text{ m}$

$$\Delta p = 3875 \text{ Pa} = 395 \text{ mm wc}$$

The two check valves in the station (2 x 200 mm wc) are sufficient for an installation height of 10 m and a temperature difference between the collector and the tank of up to 62 K.

9 Commissioning report

Installation operator _____

Location of installation _____

Collectors (number / type) _____

 Collector surface _____ m²

Installation height _____ m (Difference in height between station and collector field)

 Pipes $\varnothing =$ _____ mm $l =$ _____ m

 Venting (collector field)
 Manual vent valve
 Automatic deaerator
 No
 Vented

 De-aerator (station) Vented

Solar fluid (type) _____ % glycol

Antifreeze tested up to: _____ °C

Flow rate _____ l/m

Pump (type) _____

Pump speed level (I, II, III) _____

System pressure _____ mbars

Expansion vessel (type) _____

Initial pressure _____ mbars

 Pressure relief valve Checked

 Check valves Checked

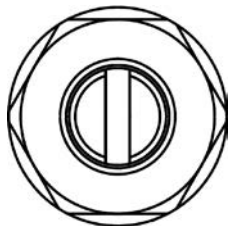
Serial numbers	
Station	
Controller	
Software version	
Restrictor position:	

Plumbing company

Date, signature

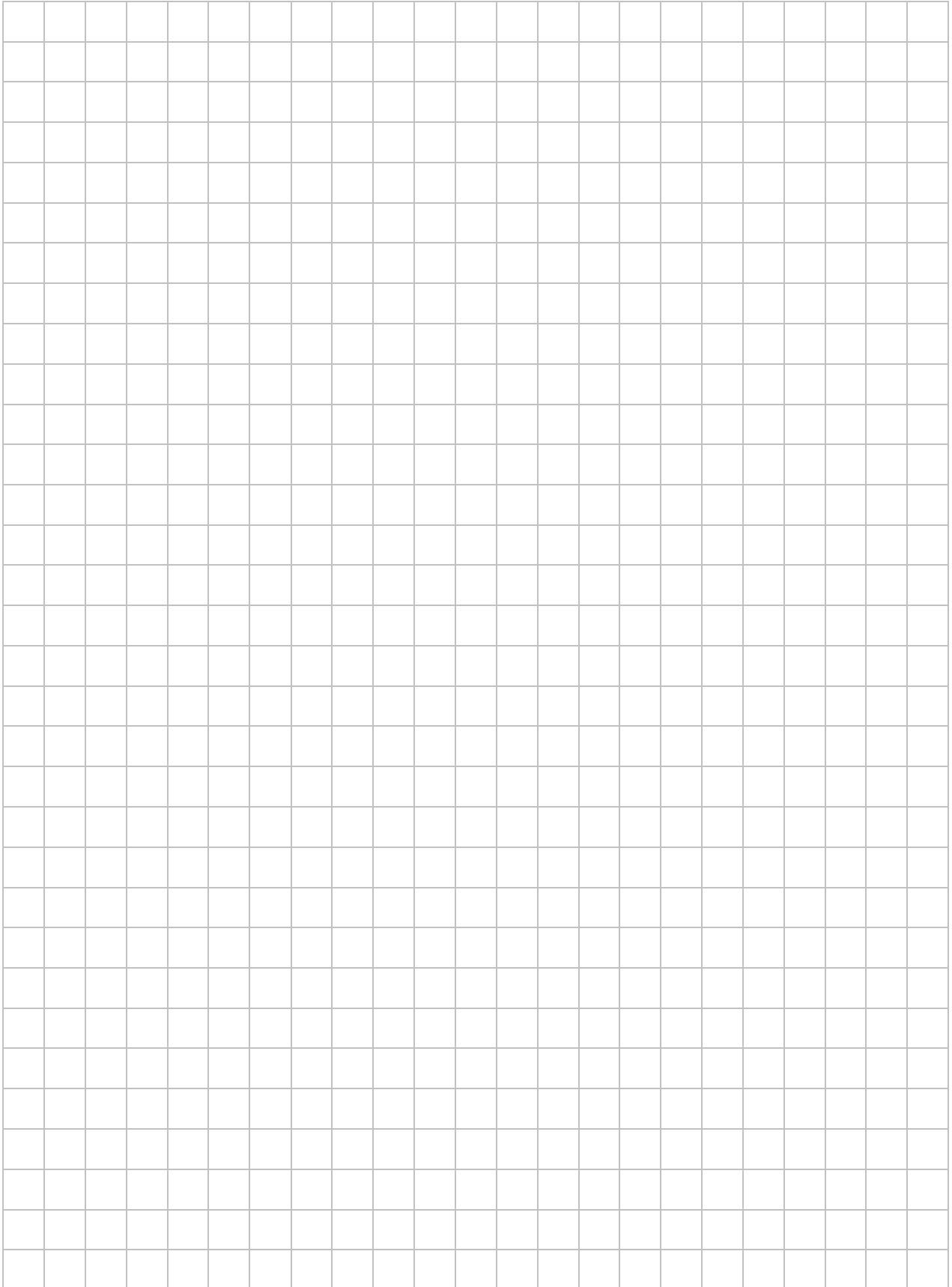

Notes

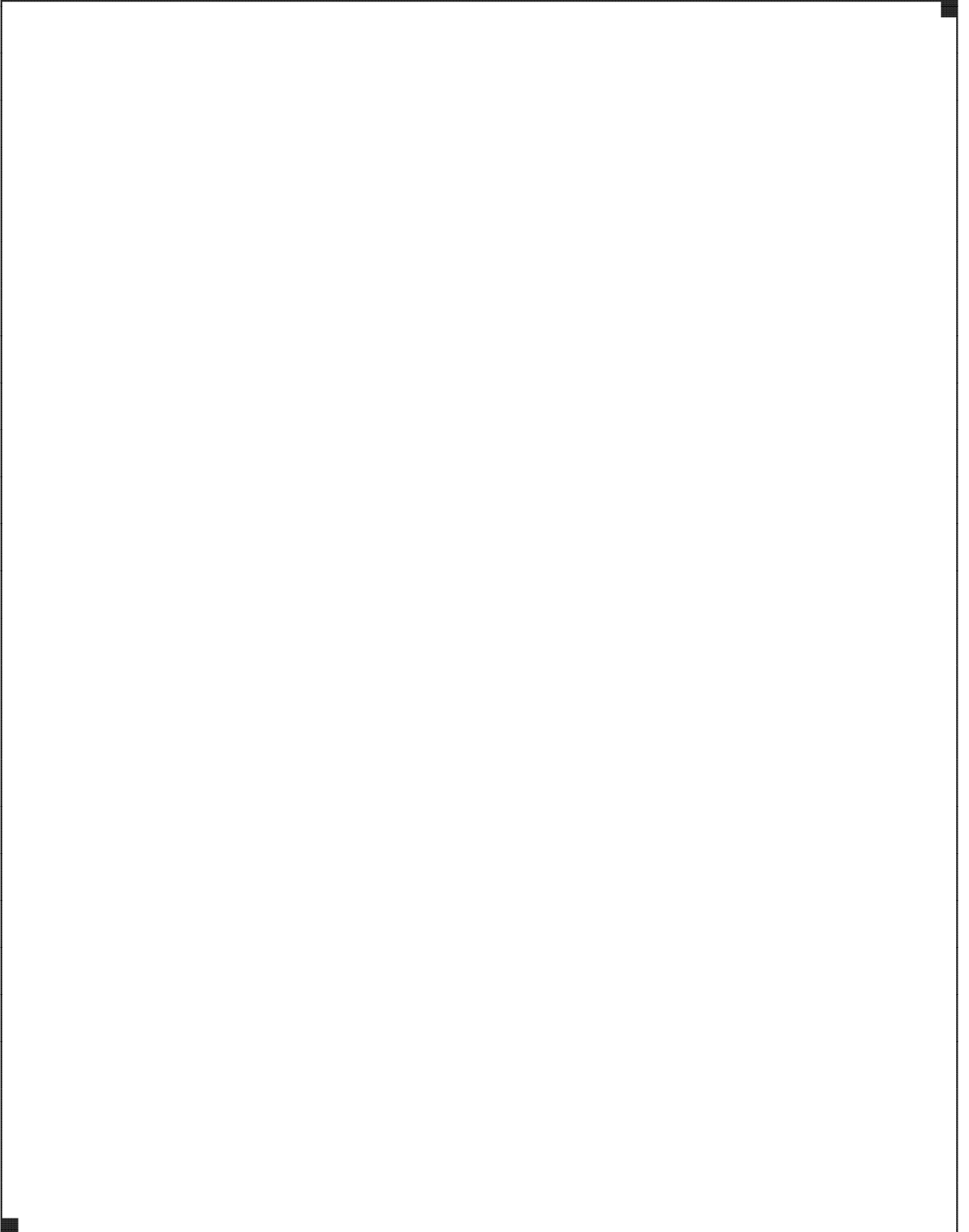

Hamworthy Heating Accredited Agents

Southern Ireland (Sales & Service)

HEVAC Limited
Naas Road, Dublin 12, Ireland
tel: **00 353 141 91919** fax: **00 353 145 84806**
email: **info@hevac.ie**

Scotland (Sales & Service)

McDowall Modular Services
2 Penson Road, Queenslie Industrial Estate, Glasgow, G33 4AG
tel: **0141 336 8795** fax: **0141 336 8954**
email:
MMS.McDowallModularServices@hamworthy-heating.com

Northern Ireland (Sales & Service)

HVAC Supplies Limited
Unit A6, Dargan Court, Dargan Crescent, Belfast BT3 9JP
tel: **028 9077 7737**
email: **hvacsupplies@btconnect.com**

North East England (Service)

Allison Heating Products
12 Sunnyside Lane, Cleadon Village, Sunderland SR6 7XB
tel: **0191 536 8833** fax: **0191 536 9933**
email: **allison.heating@gmail.com**

Hamworthy Heating Customer Service Centre

Sales

tel: **01202 662552**
email: **sales@hamworthy-heating.com**

Technical Enquiries

tel: **01202 662505**
email: **technical@hamworthy-heating.com**

Servicing

tel: **01202 662555**
email: **service@hamworthy-heating.com**

Spares

tel: **01202 662525**
email: **spares@hamworthy-heating.com**

British engineering excellence from Hamworthy Heating;
the commercial heating and hot water specialists.



Customer Service Centre

Hamworthy Heating Limited,
Wessex House,
New Fields Business Park,
Stinsford Road,
Poole,
Dorset,
BH17 0NF

Telephone: **01202 662500**
Fax: **01202 662522**
Email: **service@hamworthy-heating.com**
Website: **www.hamworthy-heating.com**