

Thermor 

NOVA PLUS

Premium design compact water heater
to fit any spaces



SAFETY

- New generation PRCD system for enhanced protection against current leakage



DURABILITY

- Magnesium anode for increased tank protection and a longer lifetime of the water heater
- New generation diamond-quality enamel



USER FRIENDLINESS

- Heating and shower ready light indicator
- Digital display of temperature
- Ergonomic front knob



ENERGY SAVINGS

- Eco position and reinforced high-density insulation for greater energy savings
- High-efficiency water inlet

www.thermor.com

THERMOSTAT

Digital display

Eco position



Heating and shower ready indicator

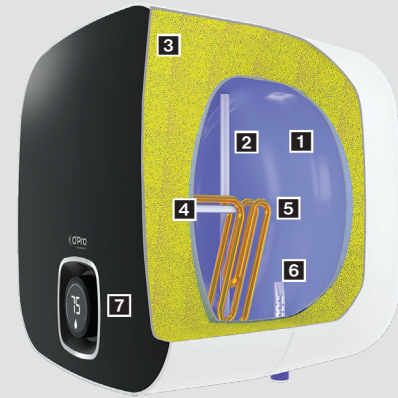

- 1 Diamond-quality glass lining for long life and reliability
- 2 Optimised stainless steel outlet pipe
- 3 High-density, 0% CFC polyurethane foam
- 4 Magnesium anode for protection against corrosion
- 5 Copper heating element
- 6 Optimised inlet diffuser
- 7 Electronic regulation for temperature control accuracy

O'Pro
TECHNOLOGY

EXCLUSIVE ANTI-CORROSIVE SYSTEM

O'Pro technology uses an ohmic resistor. It balances out the electric potentials of both the tank and the heating element. Thus, the magnesium anode life is considerably increased and protection against corrosion is reinforced.

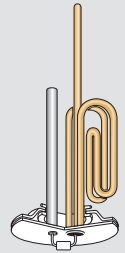

TECHNICAL DATA

Model	Installation type	Output (W)	Voltage (V)	Heat-up time ($\Delta t=45^{\circ}\text{C}$) (min)	Heat-up time ($\Delta T=35^{\circ}\text{C}$) (min)
15	Above sink	350	220-240	135	105
30	Above sink	500	220-240	189	147

INSTALLATION DIMENSIONS

Model	Inlet/outlet connections	Dimensions (mm)						Flange opening (\varnothing) mm	Net weight (kg)
		A	B	C	D	E	F		
15	1/2"	387	360	321	100	100	62	78	8
30	1/2"	467	440	389	111	100	62	78	11.8

IP 24

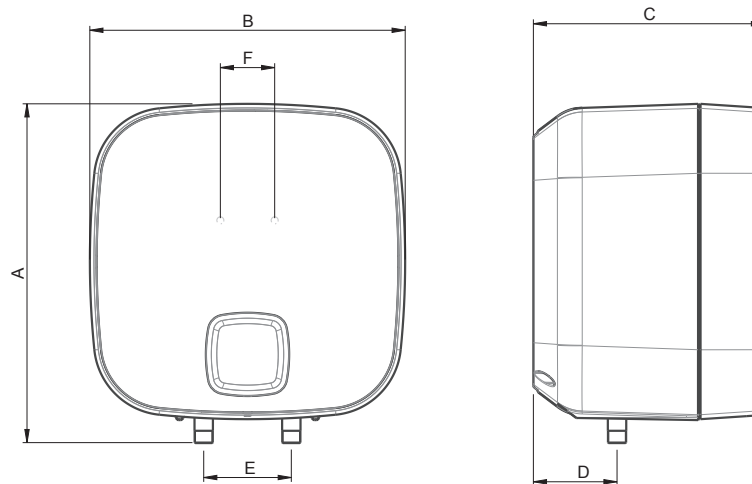

Atlantic international a simplified joint-stock company with €2 000 007 - 44 Boulevard des Etats-Unis 85000 LA ROCHE-SUR-YON. FRANCE - RCS La Roche-sur-Yon : 390 284 693 - L2R.fr - No contractual pictures - English - March 2022

Thermor