

Hydraulic scheme 1

Scheme 1: Sealed system with low loss header

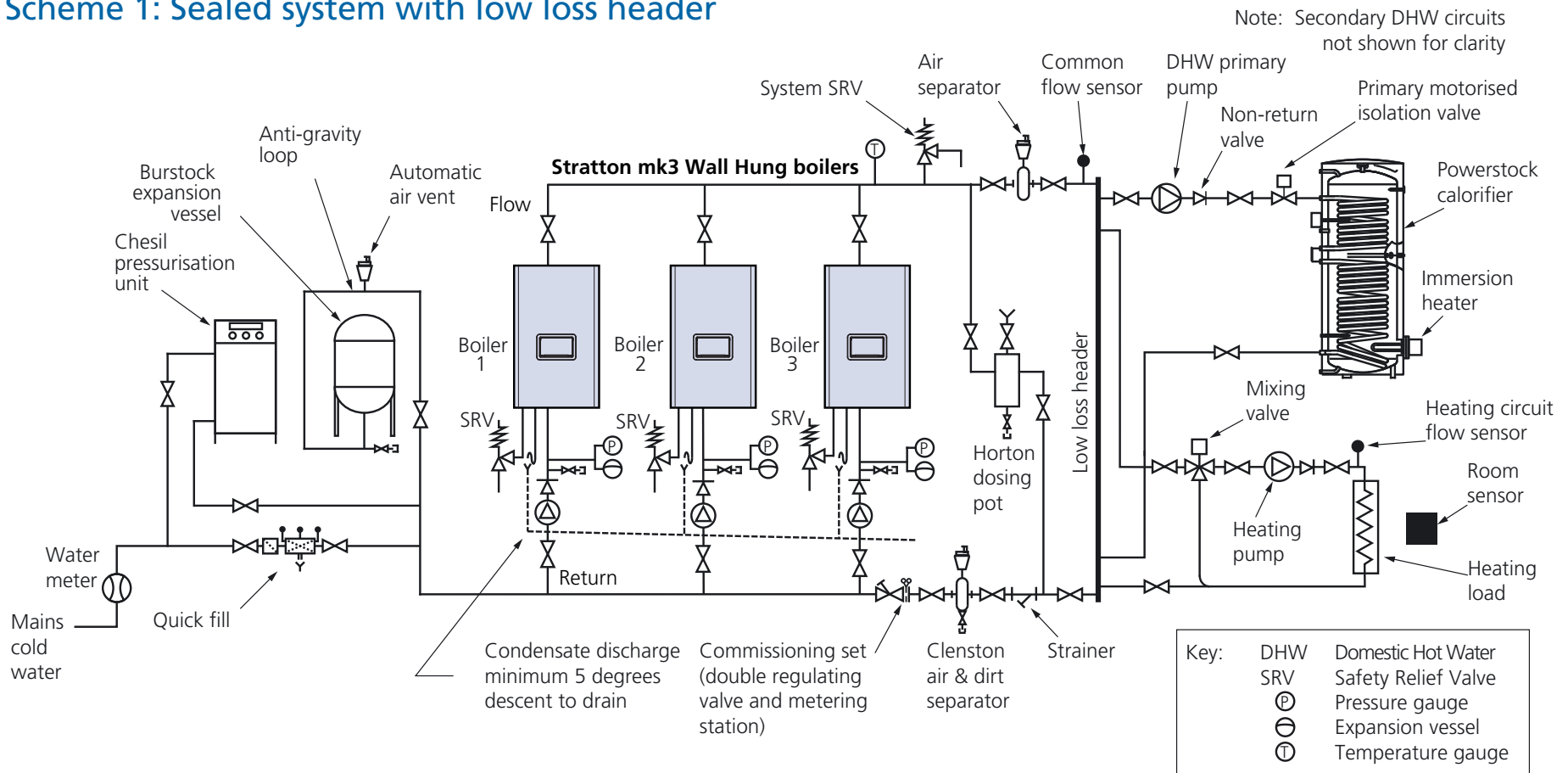

Note: These schematics have been provided for reference only.

Hydraulic circuits should never impede circulation through the boilers. The use of a low loss header is strongly recommended, or use of a plate heat exchanger for hydraulic separation to ensure adequate boiler flow.

Hydraulic scheme 2

Scheme 2: Sealed primary and open-vented secondary system with plate heat exchanger separation and without a low loss header

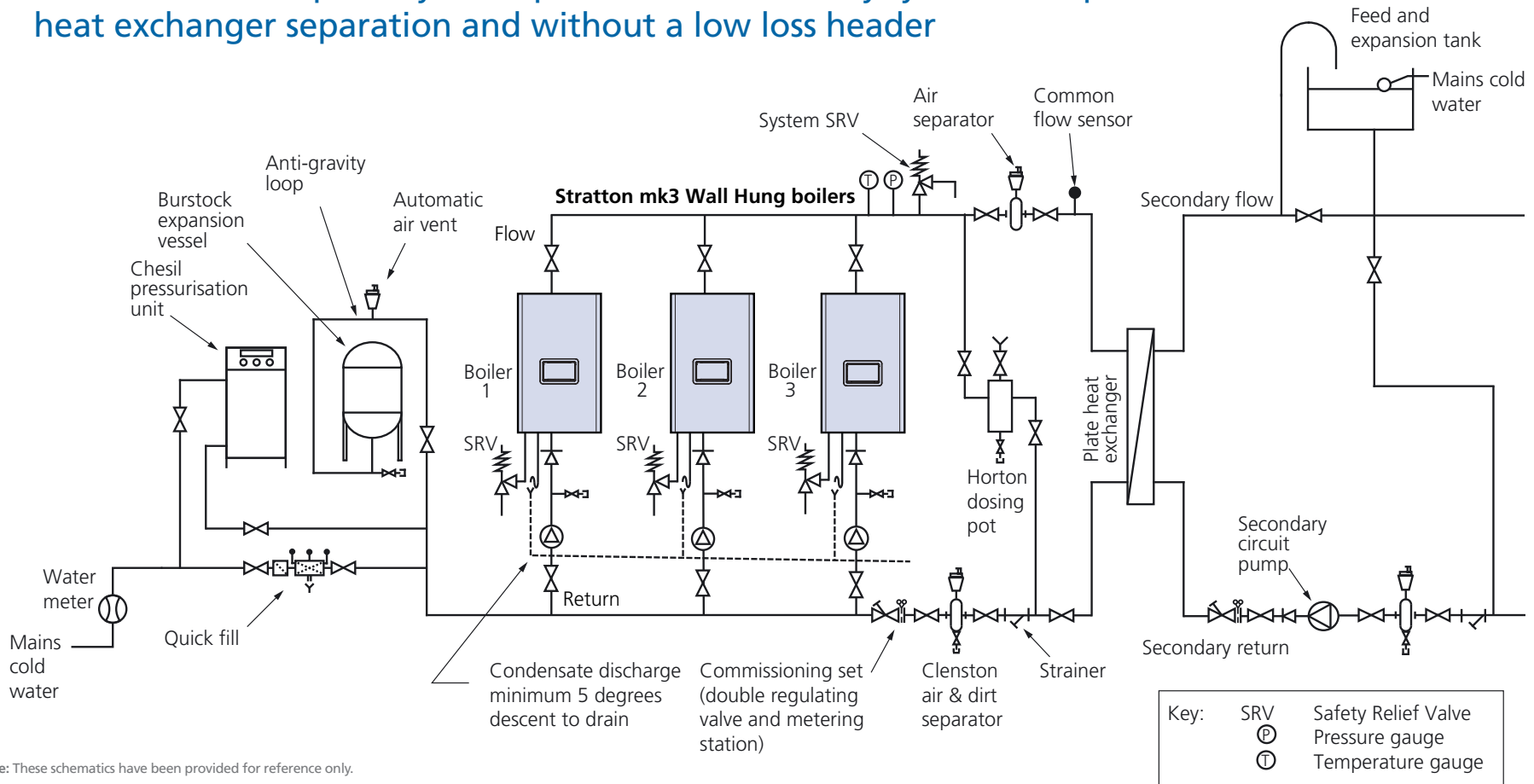

Note: These schematics have been provided for reference only.

Hydraulic circuits should never impede circulation through the boilers. The use of a low loss header is strongly recommended, or use of a plate heat exchanger for hydraulic separation to ensure adequate boiler flow.