

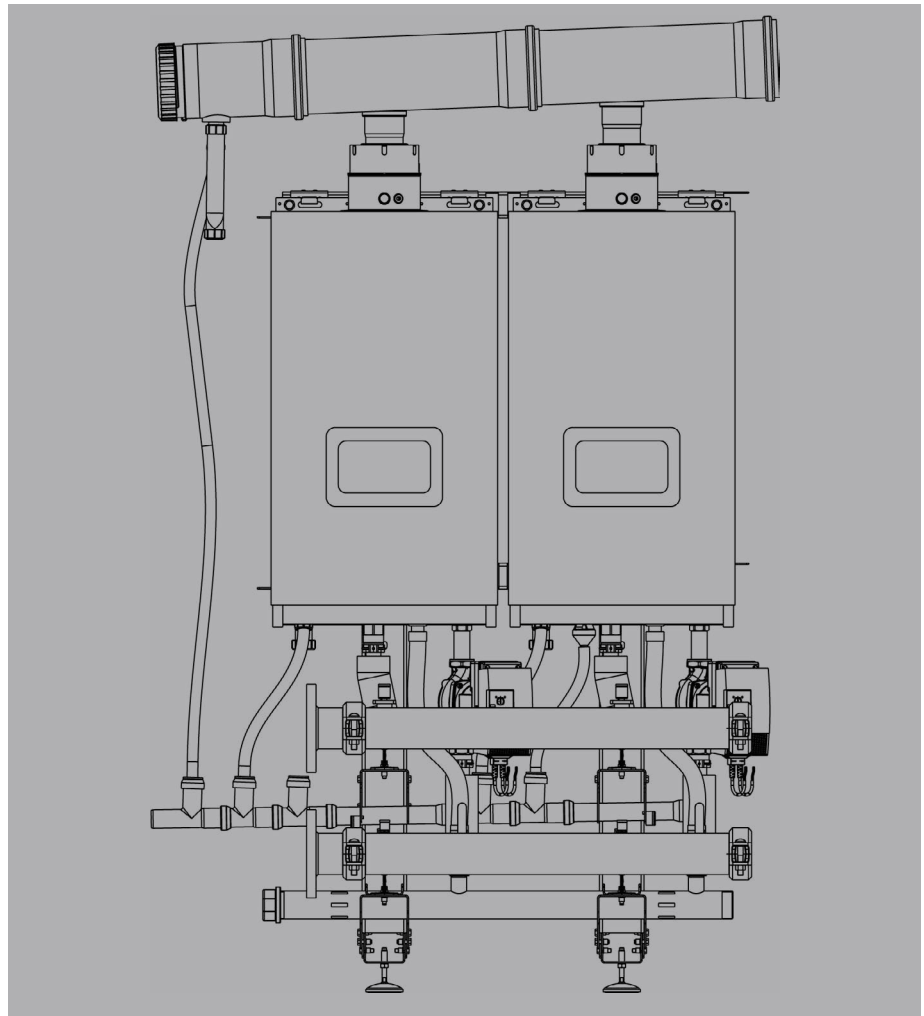

NOTICE D' INSTALLATION, INSTALLATION INSTRUCTIONS
MANUAL DE INSTALACIÓN, HANDLEIDING: INSTALLATIE

VARFREE EVO

Pack idraulico e
kit di collegamento dei
fumi per cascate caldaie
su telaio autoportante



00U07422680-A



INDICE

1. DESCRIZIONE.....	4
1.1. Introduzione	4
1.2. Caratteristiche dimensionali	4
1.3. Caratteristiche tecniche.....	7
1.4. Avvertenza	7
1.5. Altezze manometriche disponibili	8
2. COMPOSIZIONE DEI COLLI	9
3. TELAIO.....	13
3.1. Elenco dei componenti.....	13
3.2. Assemblaggio.....	14
4. VALVOLA DI SICUREZZA.....	22
4.1. Elenco dei componenti.....	22
5. CALDAIE SU TELAIO.....	23
6. TUBI SCARICO CONDENSA.....	24
6.1. Elenco dei componenti.....	24
6.2. Assemblaggio.....	25
7. COLLETTORE GAS	29
7.1. Elenco dei componenti.....	29
7.2. Assemblaggio.....	30
8. COLLETTORE IDRAULICO	33
8.1. Elenco dei componenti.....	33
8.2. Assemblaggio cascata Duo.....	34
8.3. Assemblaggio cascata Trio	37
8.4. Assemblaggio cascata Quatro	39
9. COLLEGAMENTO IDRAULICO CALDAIA.....	43
9.1. Elenco dei componenti.....	43
9.2. Assemblaggio.....	44
10. COLLEGAMENTO CONDENSA, VALVOLA E GAS.....	50
10.1. Elenco dei componenti.....	50
10.2. Assemblaggio.....	51
11. COLLEGAMENTO KIT SICUREZZE INAIL.....	54
11.1. Elenco dei componenti	54
11.2. Assemblaggio	54
12. COLLEGAMENTO FILTRO E REGOLATORE GAS	57
12.1. Elenco dei componenti	57
12.2. Assemblaggio.....	57
13. COLLEGAMENTO DEI FUMI	58
13.1. Elenco dei componenti.....	58
13.2. Assemblaggio.....	59

1. DESCRIZIONE

1.1. Introduzione

I kit descritti nel presente manuale sono stati pensati per facilitare la realizzazione di una cascata di 2, 3 o 4 caldaie chiamate rispettivamente cascata Duo, Trio o Quattro. Per maggiori informazioni sulla caldaia, fare riferimento al manuale della caldaia.

Trattandosi di una centrale termica, il locale caldaia dovrà avere caratteristiche dimensionali e prescrizioni conformi alle norme locali vigenti.

Anche, l'installazione e la manutenzione della cascata devono essere effettuate da un professionista qualificato, conformemente ai testi regolamentari e alle regole dell'arte in vigore nel Paese d'installazione delle caldaie.

1.2. Caratteristiche dimensionali

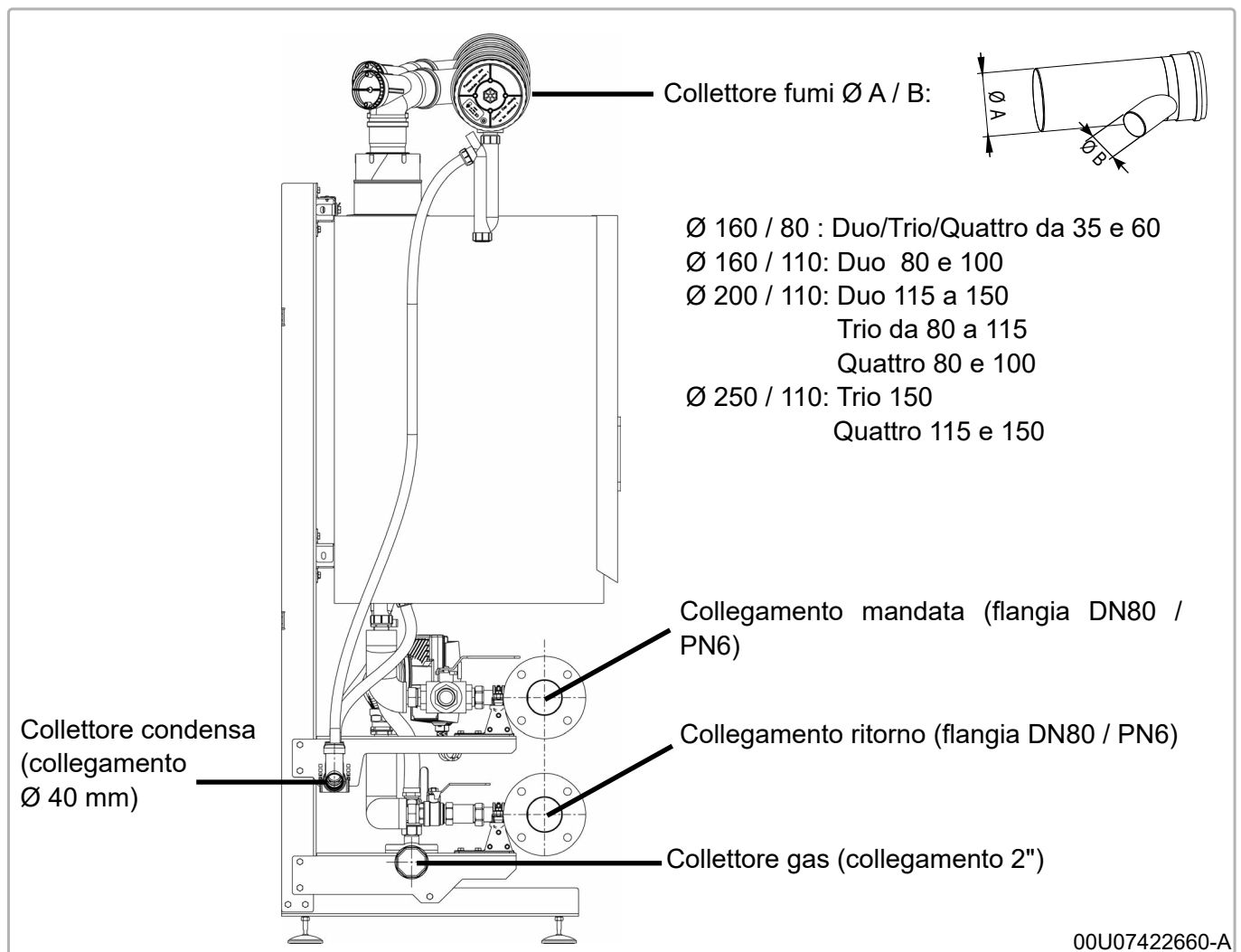
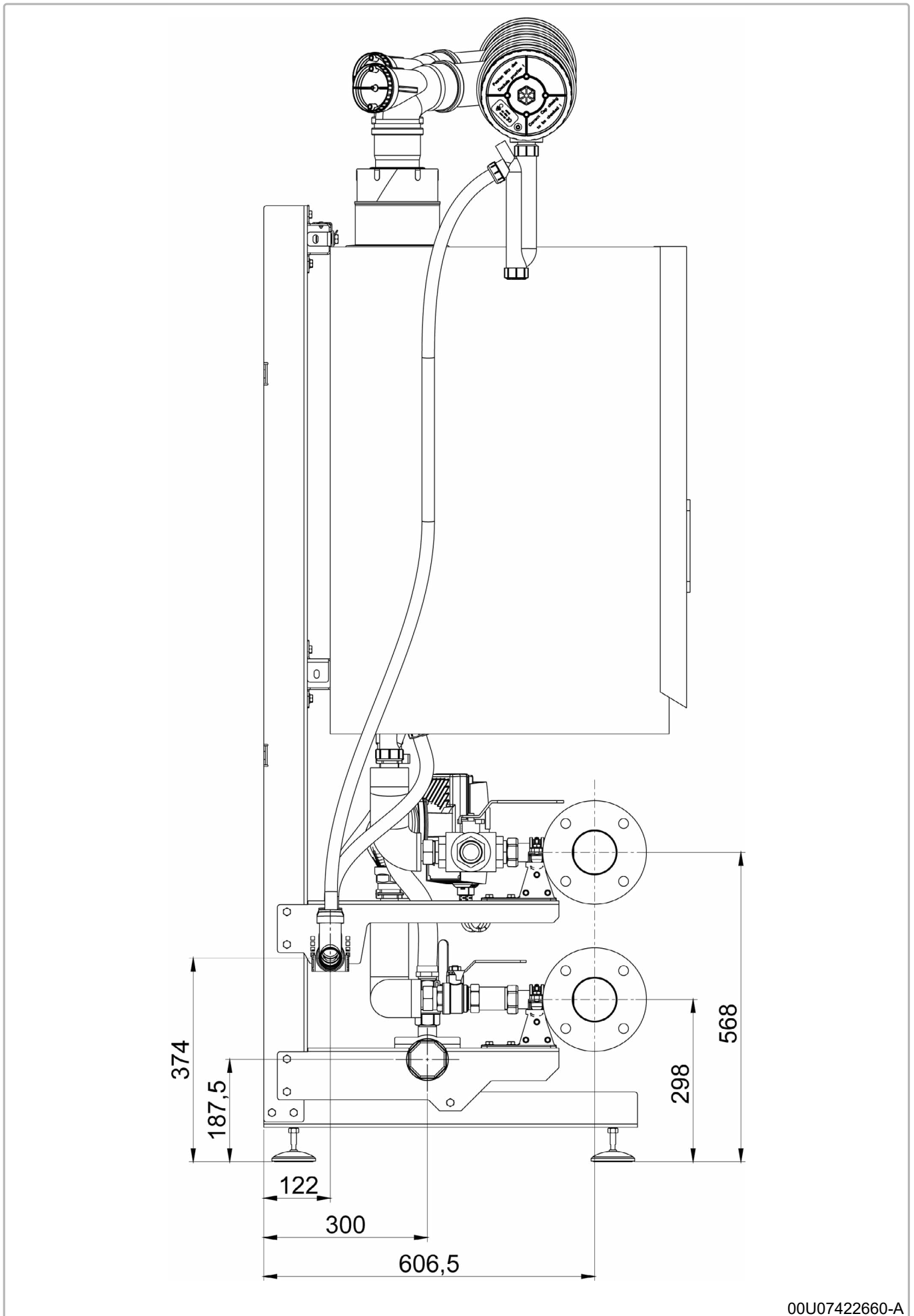

figure 1 - Componenti da collegare



00U07422660-A

figure 2 - Posizione dei collegamenti

00U07422680-A

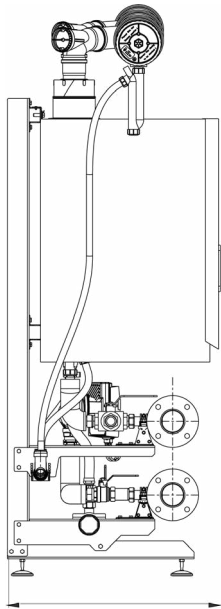

80-150 = 781,5
40-60 = 694,5

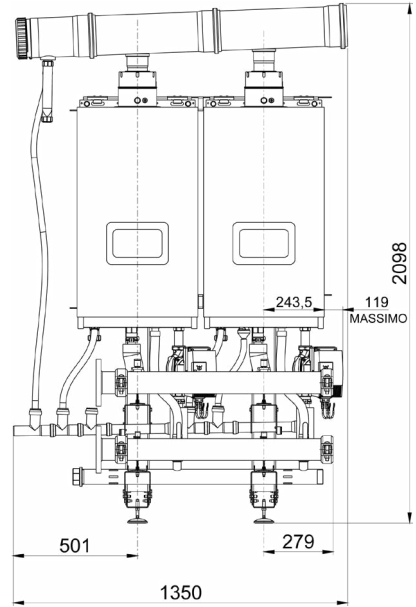

00U07422680-A

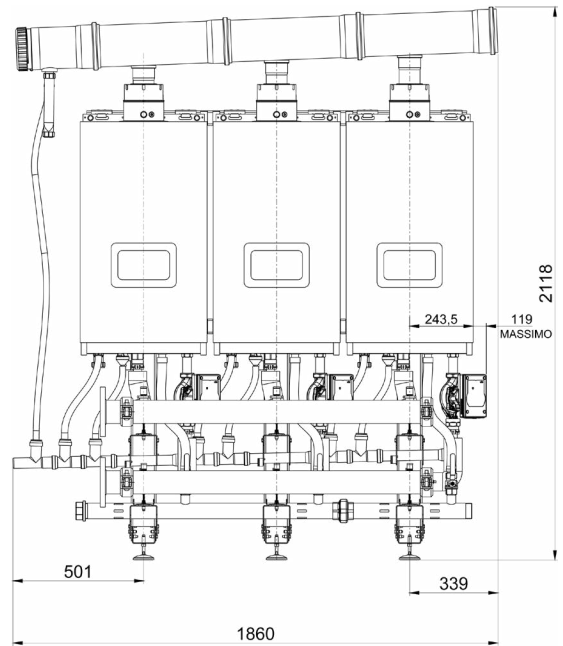

00U07422690-A

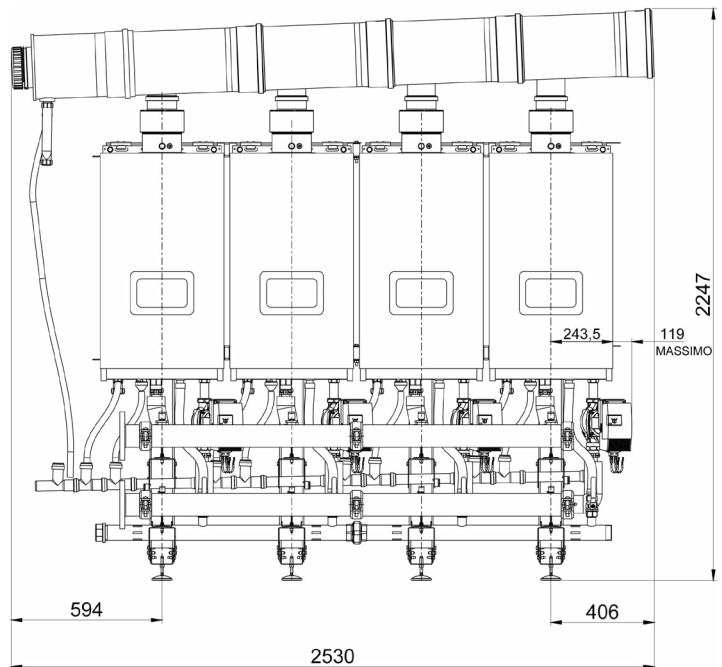

00U07422720-A

1.3. Caratteristiche tecniche

Fare riferimento al manuale di installazione, d'uso e di manutenzione fornito con le caldaie per le informazioni relative alle specifiche relative a gas, combustione e uso (da riportare nella tabella qui sotto per indicare le caratteristiche della cascata).

	Caldaia della cascata				Totale cascata	
	A	B	C	D		
Potenza nominale (80/60 °C) Pn					A + B + C + D	kW
Potenza nominale (50/60 °C)					A + B + C + D	kW
Portata termica nominale Qn					A + B + C + D	kW
Portata termica min. Qmin					Mini delle Qmin	kW
Portata gas a Pn*					A + B + C + D	m ³ /h
Portata fumi a Qn					A + B + C + D	g/s
Portata d'aria comburente a Qn*					A + B + C + D	m ³ /h
Portata nominale di irrigazione					A + B + C + D	m ³ /h
Capacità acqua					A + B + C + D + E **	l

* a 15°C, 1013 mbar

** con E = 12 litri se cascata Duo, E = 16,5 litri se cascata Trio, e E = 23 litri se cascata Quattro

1.4. Avvertenza

Il presente manuale descrive il montaggio del kit cascata con l'alimentazione a gas e lo scarico dei fumi a destra del kit, e il boiler di disaccoppiamento e lo scarico della condensa a sinistra del kit.

È possibile modificare il lato di ciascun elemento. Per conoscere le specifiche di montaggio, fare riferimento ai relativi capitoli.

1.5. Altezze manometriche disponibili

La prevalenza utile disponibile tra il collettore di ritorno e il collettore di mandata è data dalla tabella sottostante (al netto delle perdite di carico delle caldaie e dei relativi kit di collegamento)

Modello caldaia	MODELLI					
	35	60	80	100	115	150
Portata unitaria distribuita in ogni caldaia a Pnom/20 (m ³ /h)	1.5	2.4	3.4	4.1	5.2	6.2
Portata unitaria distribuita in ogni caldaia a Pnom/20 (l/min)	25.1	39.4	57.3	68.8	86.0	103.9
PWM standard (%)	67	78	62	77	74	79
Altezza manometrica disponibile per ottenere la portata Pnom/20 aumentando il PWM (mce)	2.62	1.00	2.60	2.50	2.20	2.36
Altezza manometrica disponibile per ottenere la portata Pnom/20 aumentando il PWM (mbar)	259	99	257	247	218	233

A seconda dell'installazione, è possibile regolare il flusso in base alle proprie esigenze. Per questo :

- Verificare che l'impianto sia pieno d'acqua, spurgato con una pressione dell'acqua > 1 bar a freddo e con i circolatori fermi
 - Verificare che tutte le valvole di intercettazione manuale siano correttamente aperte
 - Accendere tutte le caldaie
 - Avviare tutte le pompe tramite il display: Selezionare il parametro 7713 dal menu "Test ingressi/uscite", quindi impostare una velocità in percentuale (impostare al minimo il valore della curva grigia corrispondente al proprio modello di pompa. caldaia) .
- Impostare prima lo stesso valore su ogni caldaia - Verificare la portata di ogni caldaia tramite il parametro 8366 del menu "Diagnostica generatore" (valore in l/min)
- Modificare il parametro velocità pompa 7713 per ottenere più o meno portata (avvicinarsi il più possibile alla portata nominale di Pnom/20 su ogni caldaia, Pnom in th/h).

ATTENZIONE: L'aumento della portata su una caldaia può influenzare la portata delle altre caldaie. Procedere per iterazioni successive. Ogni caldaia della stessa potenza deve avere la stessa portata.

Il valore minimo di portata a Pnom per ogni caldaia è Pnom/30 (Pnomen th/h).

- Una volta impostata la velocità e dopo aver verificato il corretto bilanciamento tra le diverse caldaie, inserire il valore di impostazione nei seguenti parametri:

2321 – Velocità iniziale











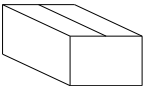

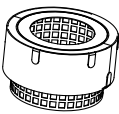
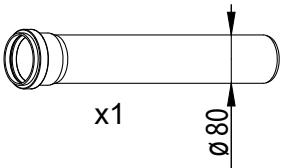

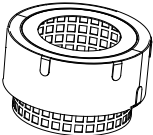
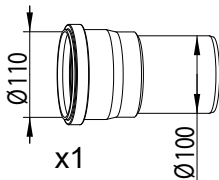

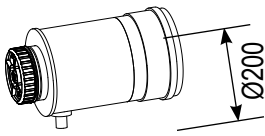

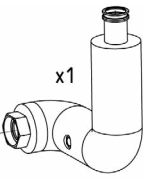

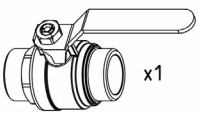
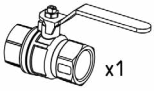
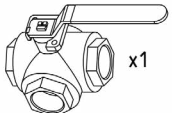
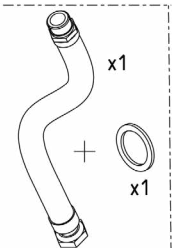



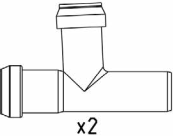
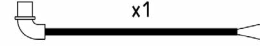
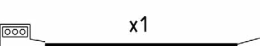



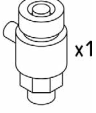

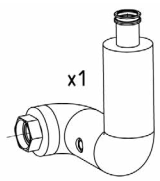
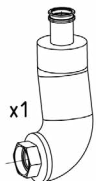
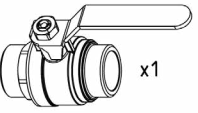
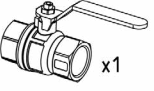
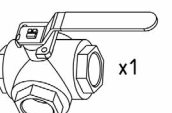
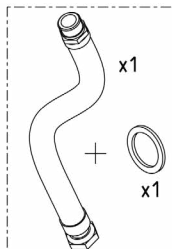
2323 – velocità massima

2322 – velocità minima

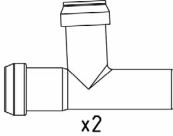
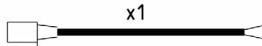
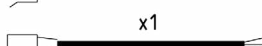
- Dopo aver modificato i parametri ripristinare il valore del parametro 7713 a - - -

Mettere in funzione tutte le caldaie, verificarne il corretto funzionamento a caldo.

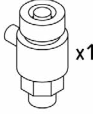
2. COMPOSIZIONE DEI COLLI

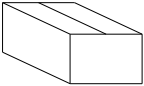
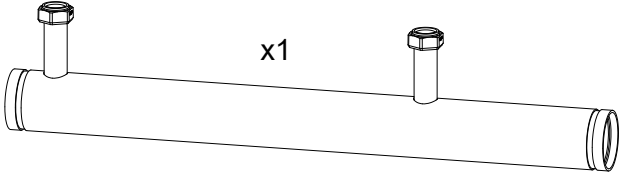
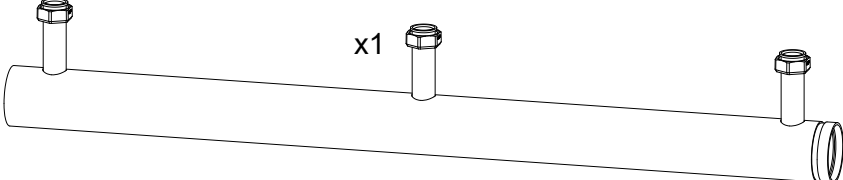
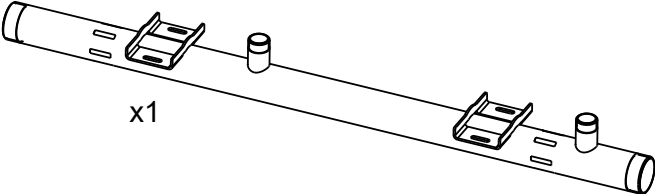
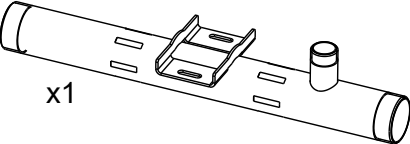
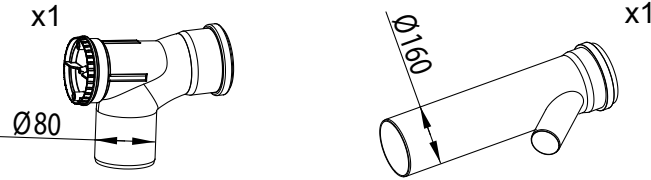
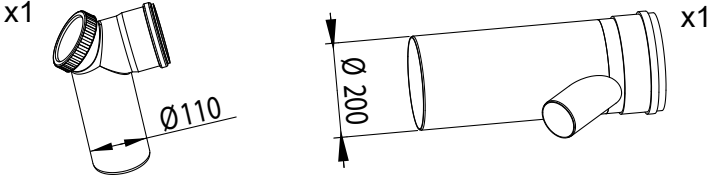
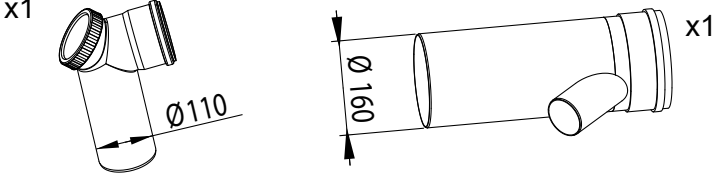
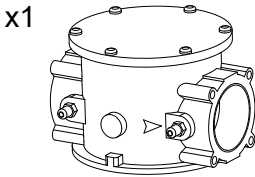

					
040945	 x1	 x1	 x1 Ø80	 GRAISSE GREASE x1	
041052	 x1	 x1 Ø110 Ø100	 GRAISSE GREASE x1		
041054	 x1	 x1 Ø200	 x1		
082667	 x1  x1	 x1  x1  x1	 x1 Ø200	 x2  x1  x1  x2  x1  x1	 x2  x2  x7  x1  x2
082668	 x1  x1	 x1  x1  x1	 x1 Ø200	 x2  x1  x1  x2  x1  x1	 x2  x2  x7  x1  x2

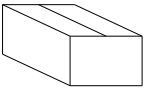
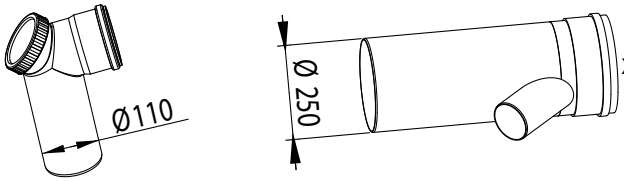
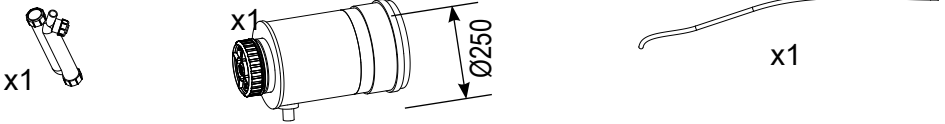
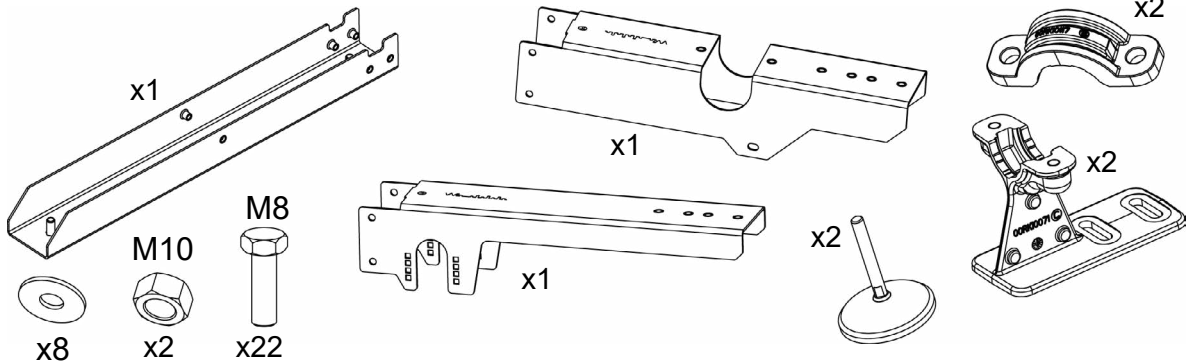
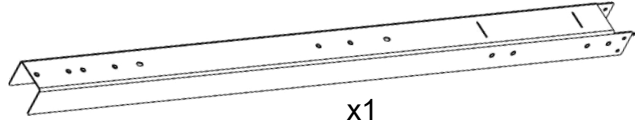
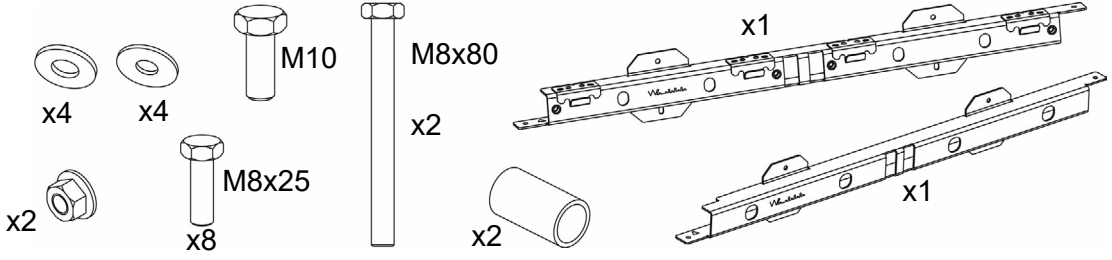
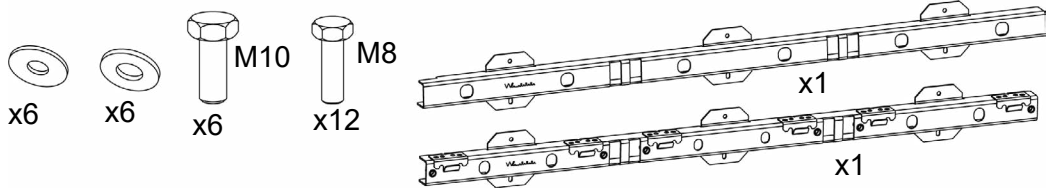
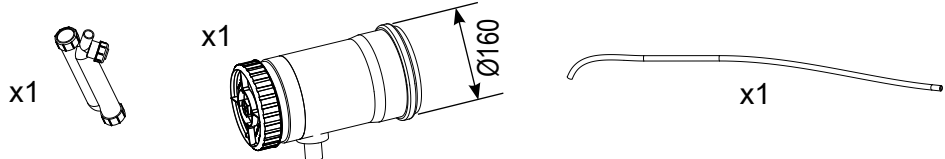
	
082710	
082711	
082712	
082713	
083848	
083849	
083850	
082321	

	
083851	 <p>x1</p>
082336	 <p>x1</p>
083377	 <p>x1</p> <p>M8</p> <p>M10</p> <p>x8</p> <p>x2</p> <p>x22</p> <p>x1</p> <p>x1</p> <p>x2</p> <p>x2</p>
082660	 <p>x1</p>
082661	 <p>x4</p> <p>x4</p> <p>M10</p> <p>M8x25</p> <p>x2</p> <p>x8</p> <p>M8x80</p> <p>x2</p> <p>x2</p> <p>x1</p> <p>x1</p>
082662	 <p>x6</p> <p>x6</p> <p>M10</p> <p>M8</p> <p>x6</p> <p>x12</p> <p>x1</p> <p>x1</p>
700391	 <p>x1</p> <p>x1</p> <p>Ø110</p> <p>Ø160</p> <p>x1</p>

3. TELAIO

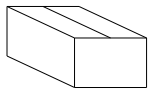
3.1. Elenco dei componenti

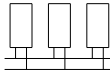
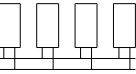
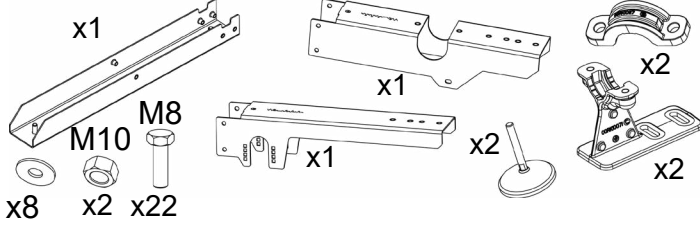
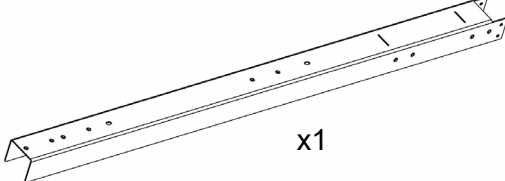
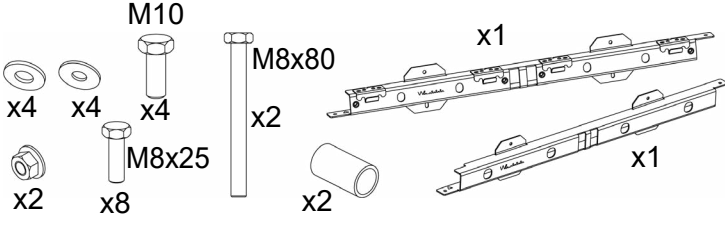
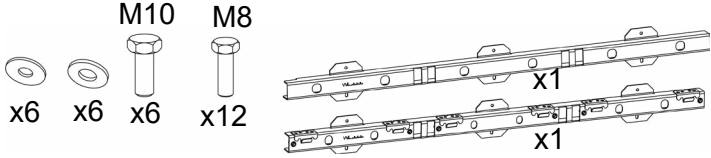
				
083377	 <p>x1 x1 x2 x8 M10 x2 M8 x22 x1 x2 x2</p>	x2	x3	x4
082660	 <p>x1</p>	x1		x2
082661	 <p>M10 x4 x4 x4 M8x80 x2 M8x25 x8 x2 x1 x1</p>		x1	
082662	 <p>M10 M8 x6 x6 x6 x12 x1 x1</p>	x2	x3	x4

3.2. Assemblaggio

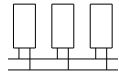
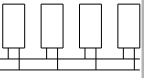
		
x2	x3	x4

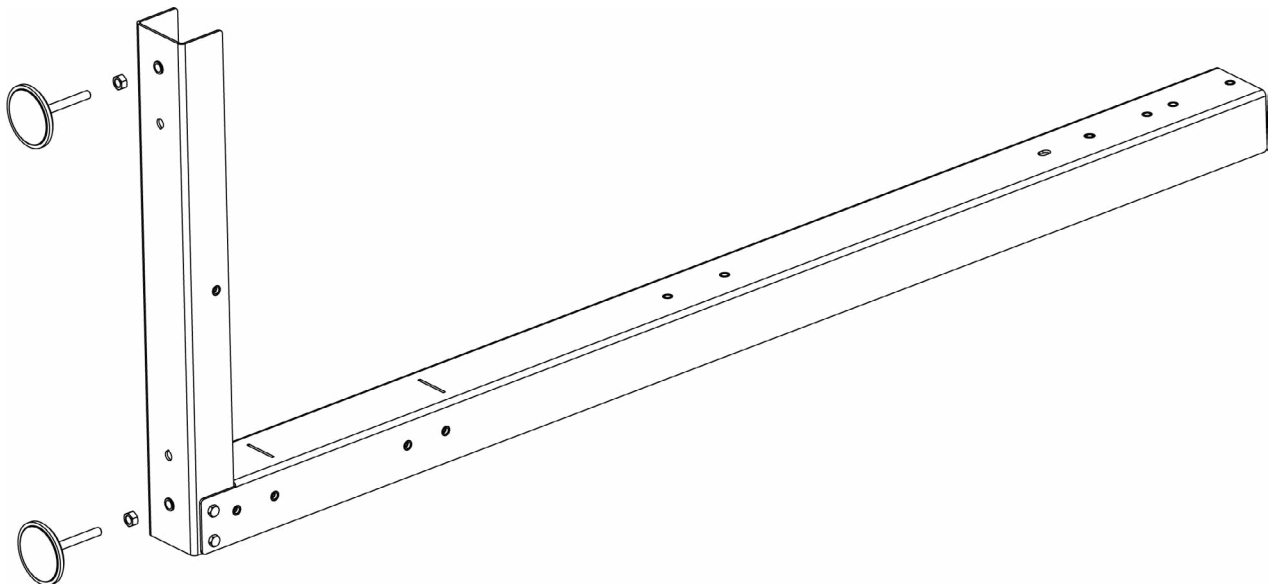
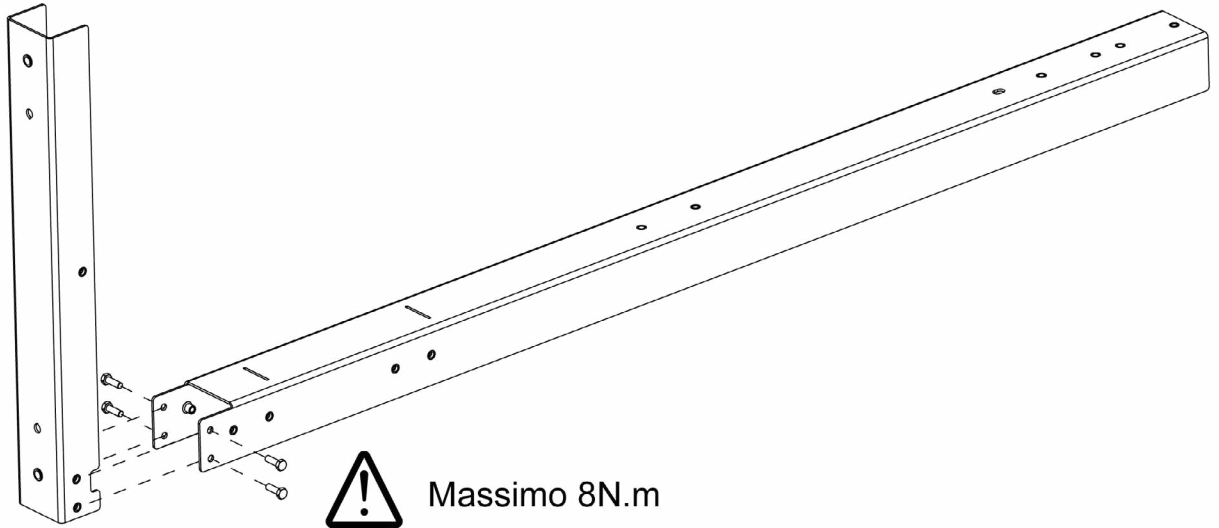

00U07399770-A

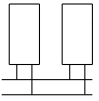

! Massimo 8 Nm

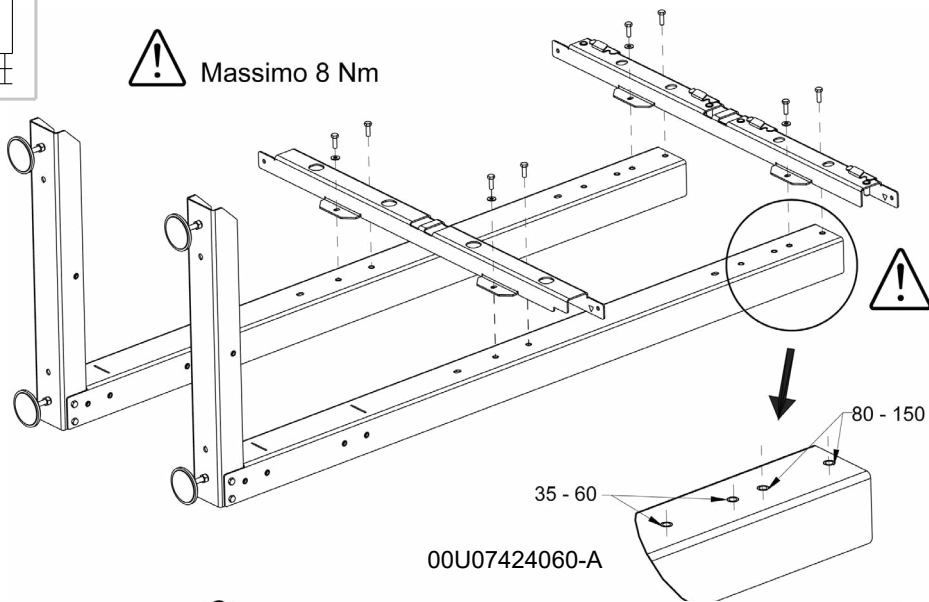

00U07424060-A

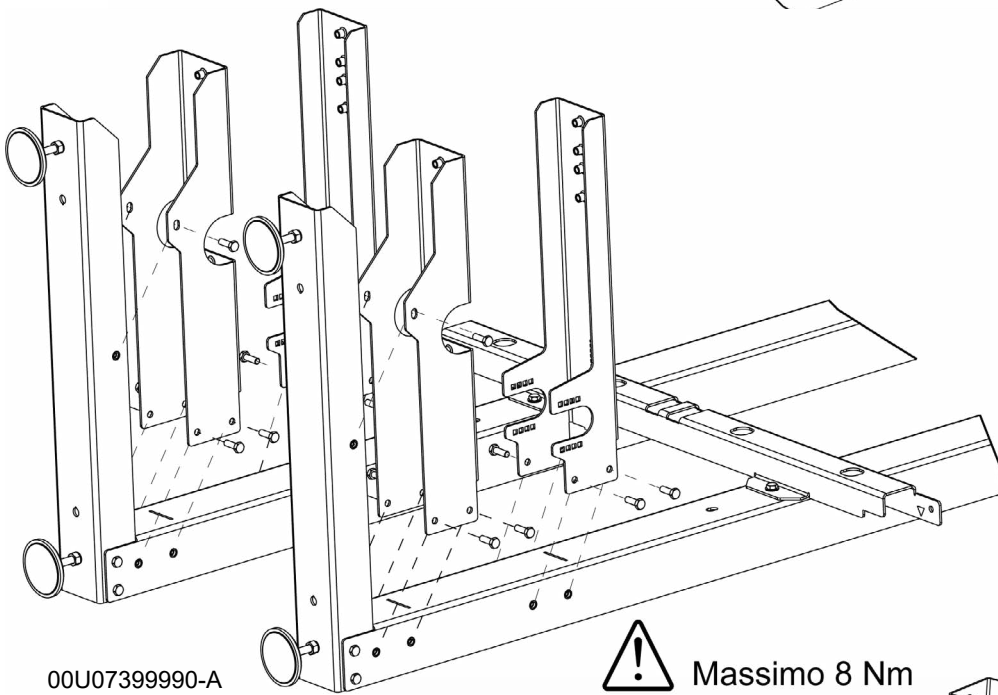

00U07399990-A

! Massimo 8 Nm

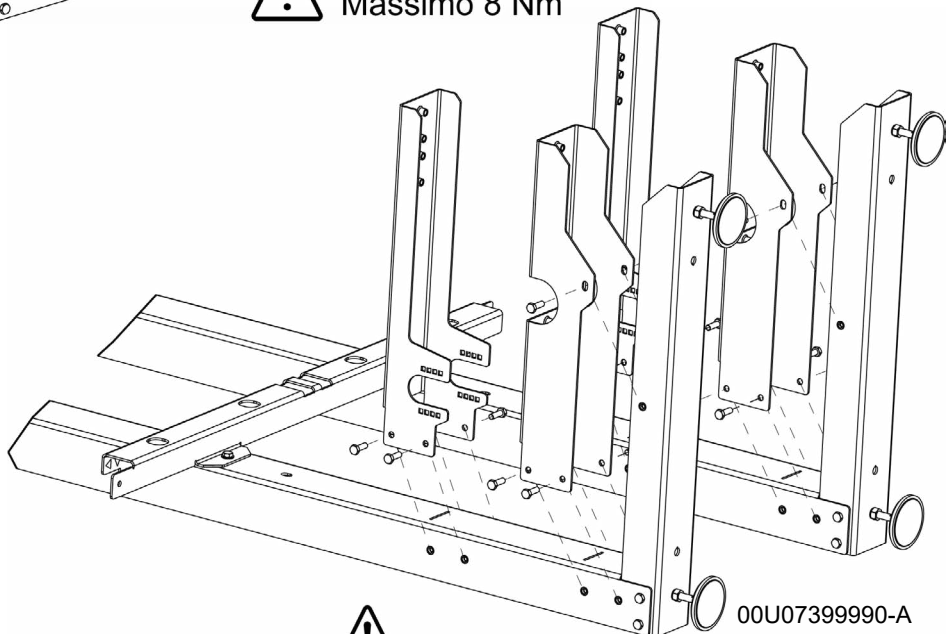

00U07399990-A

! Massimo 8 Nm

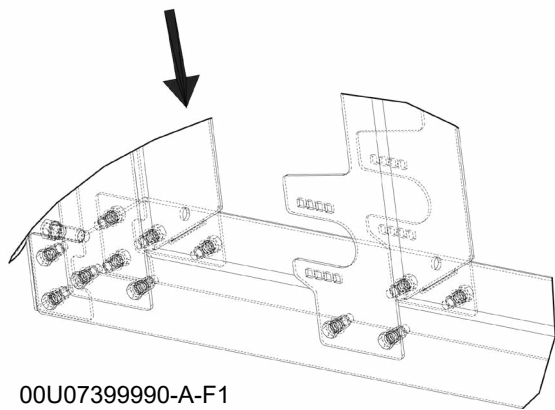
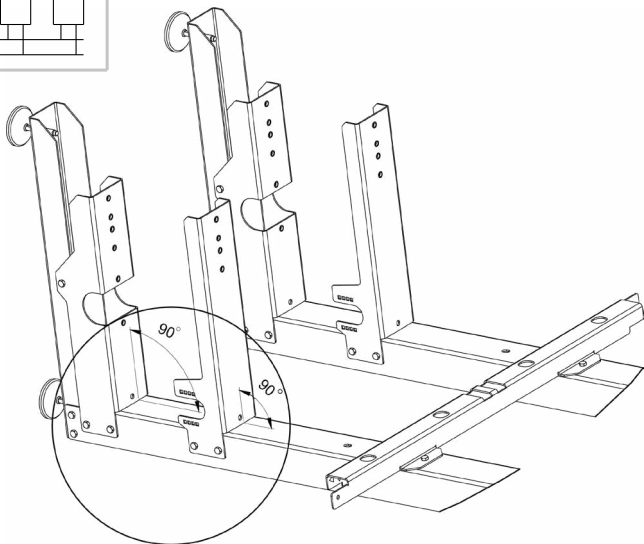
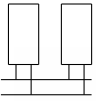

00U07399990-A-F1

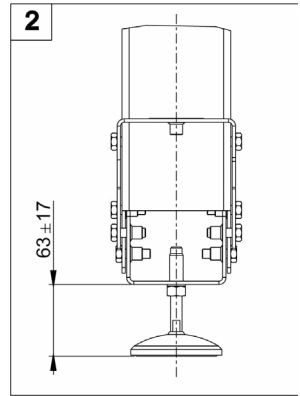
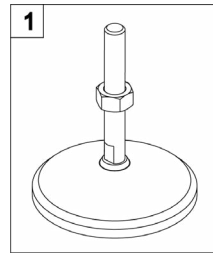

00U07404150-A

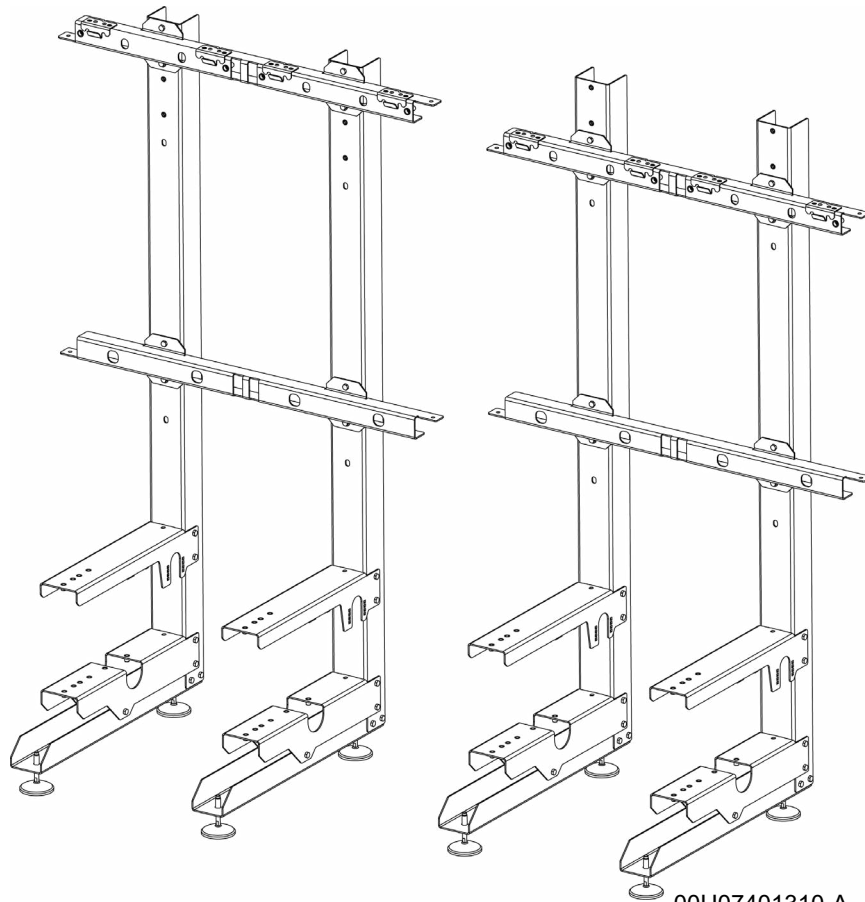

00U07401310-A

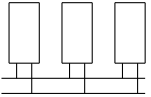

 Massimo 8 Nm

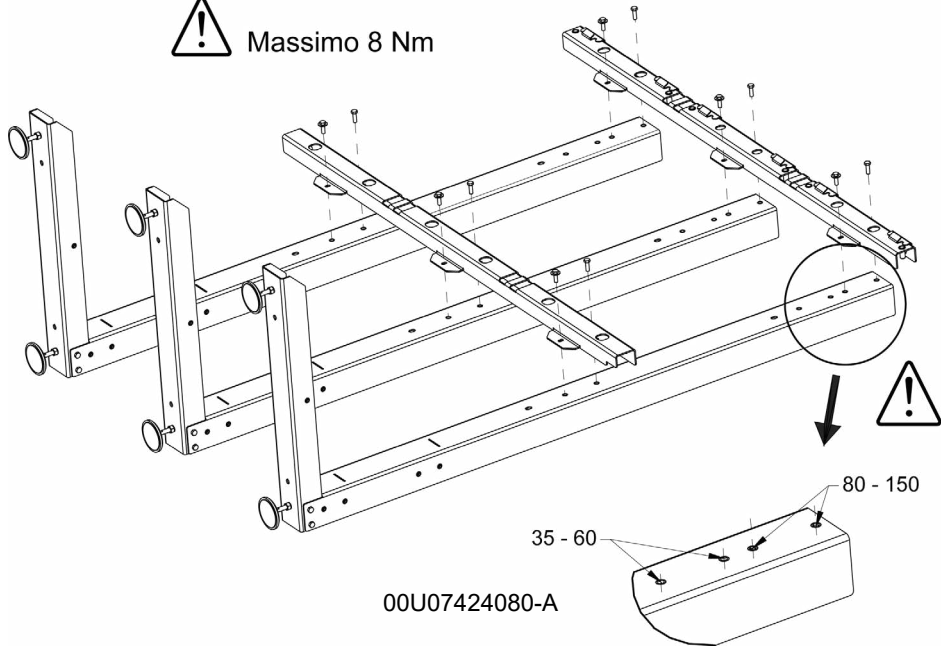

00U07424080-A

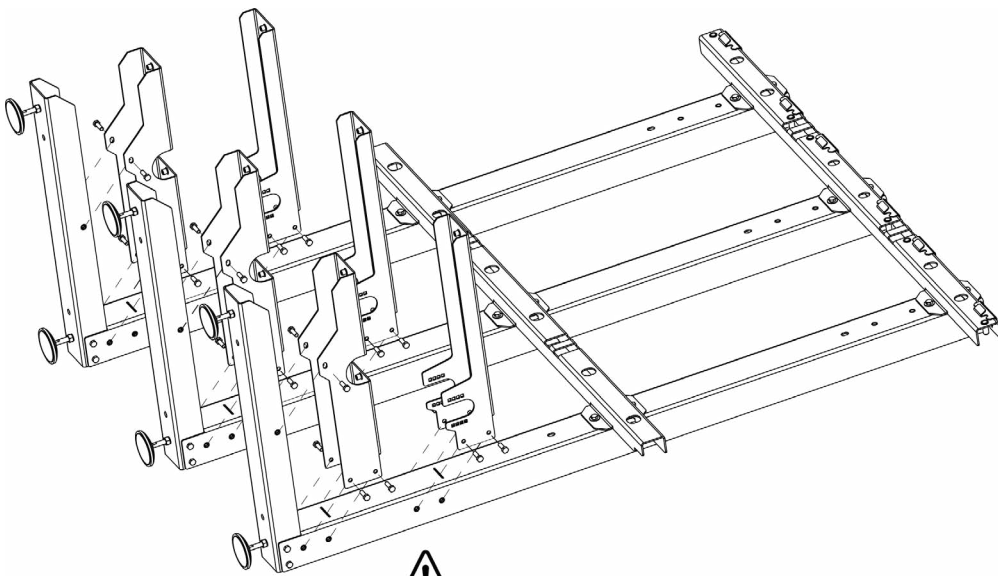

 Massimo 8 Nm

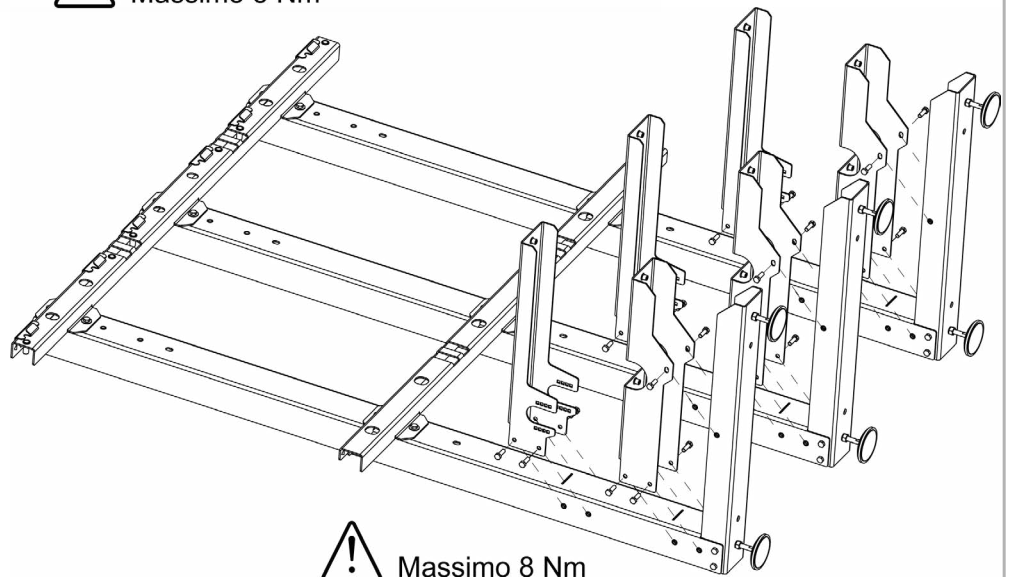

 Massimo 8 Nm

00U07403070-A

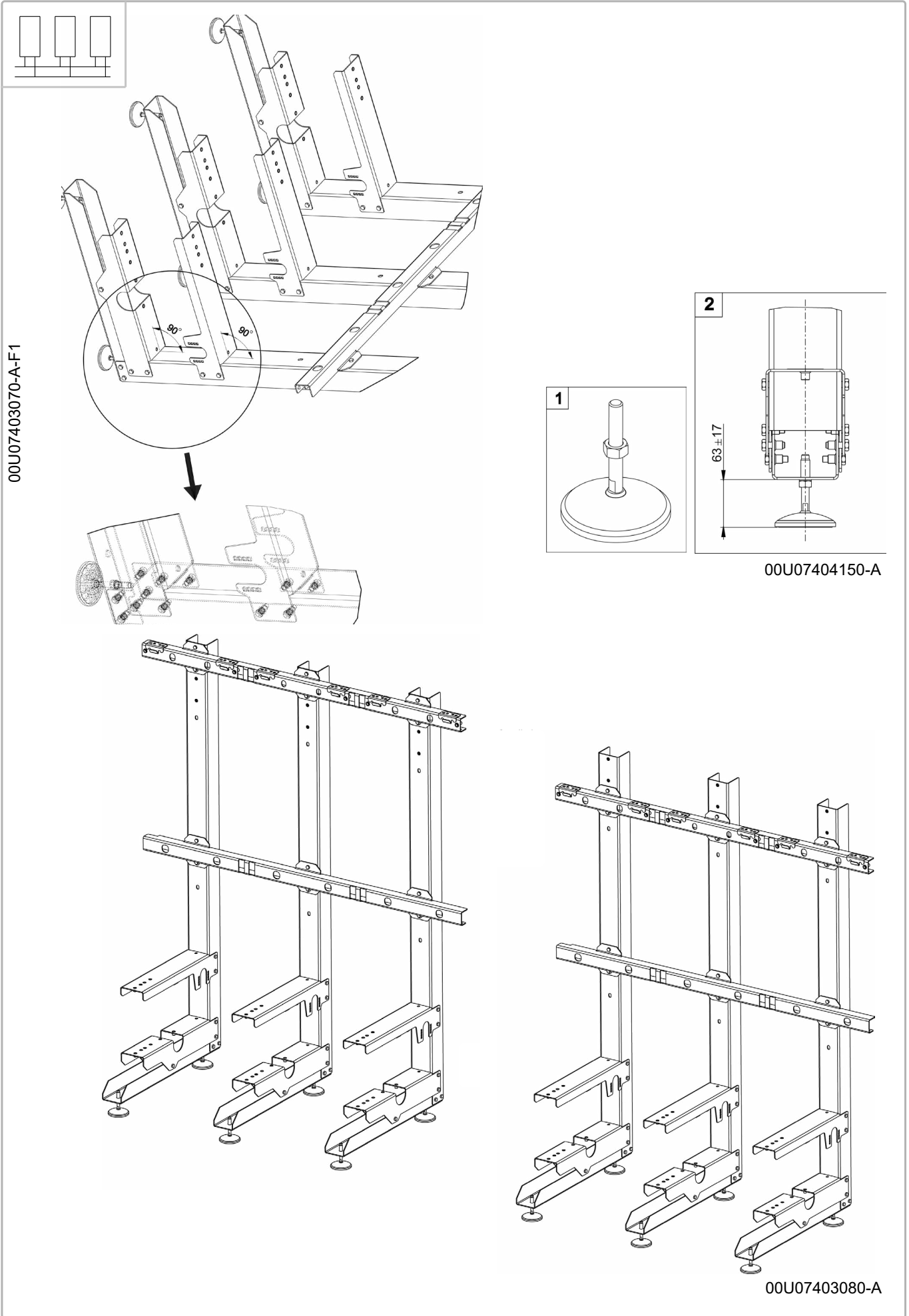

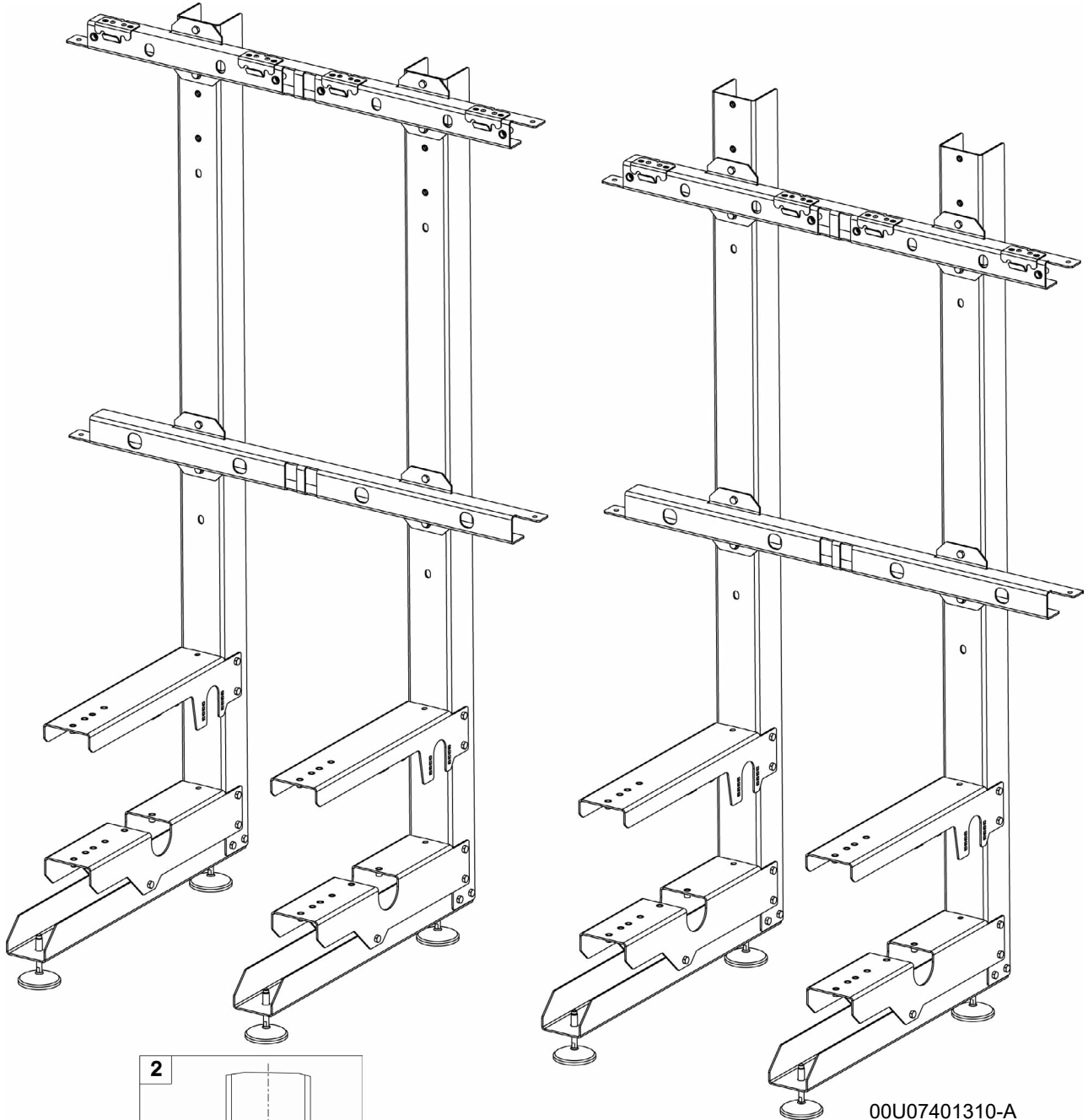
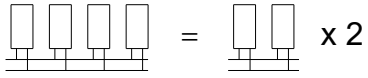
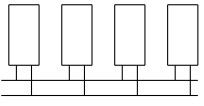

00U07401310-A

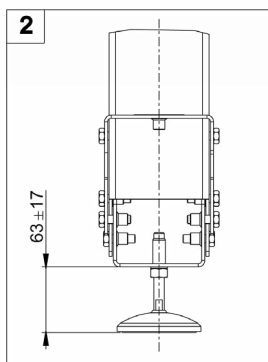
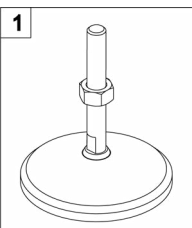

00U07404150-A

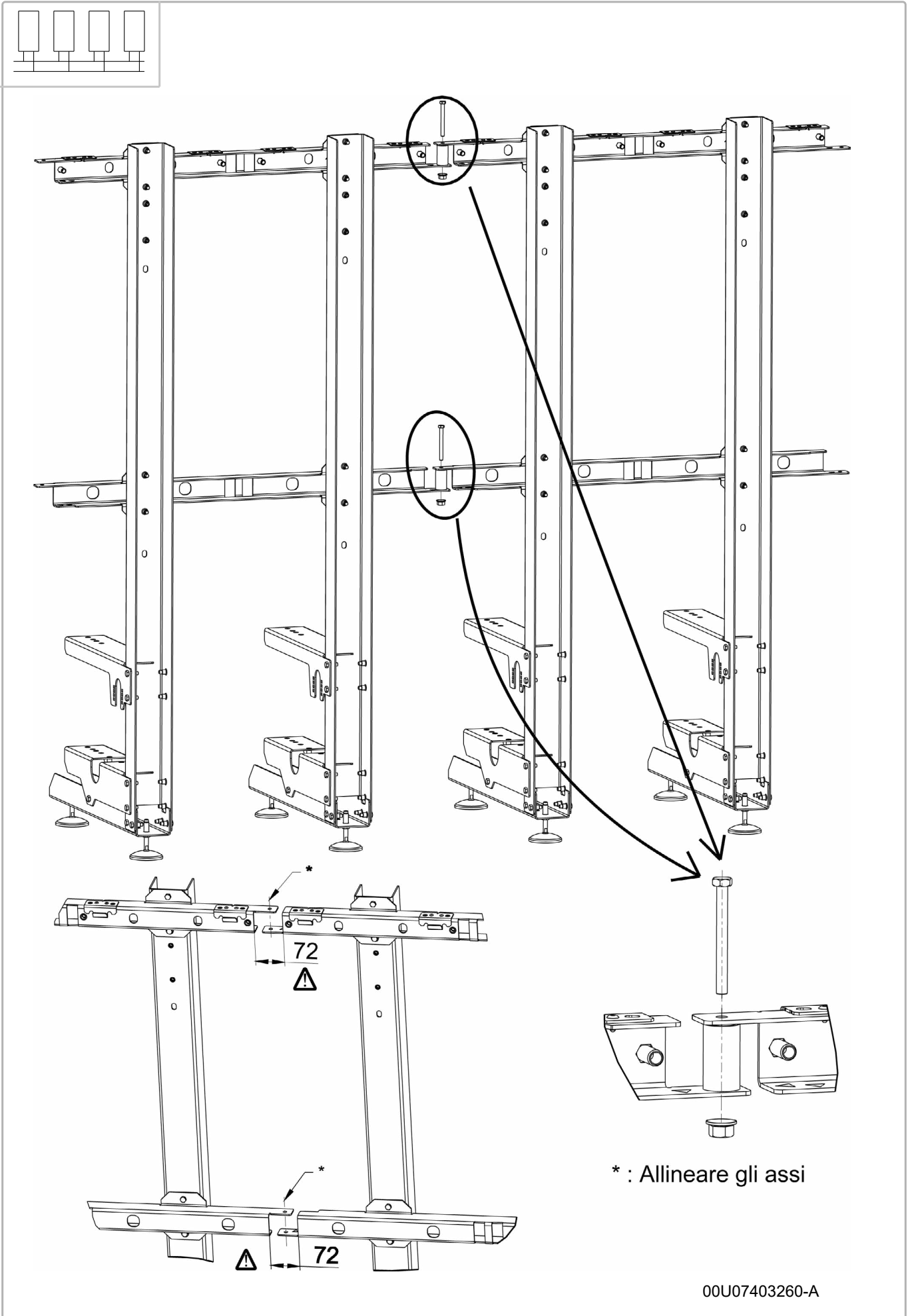

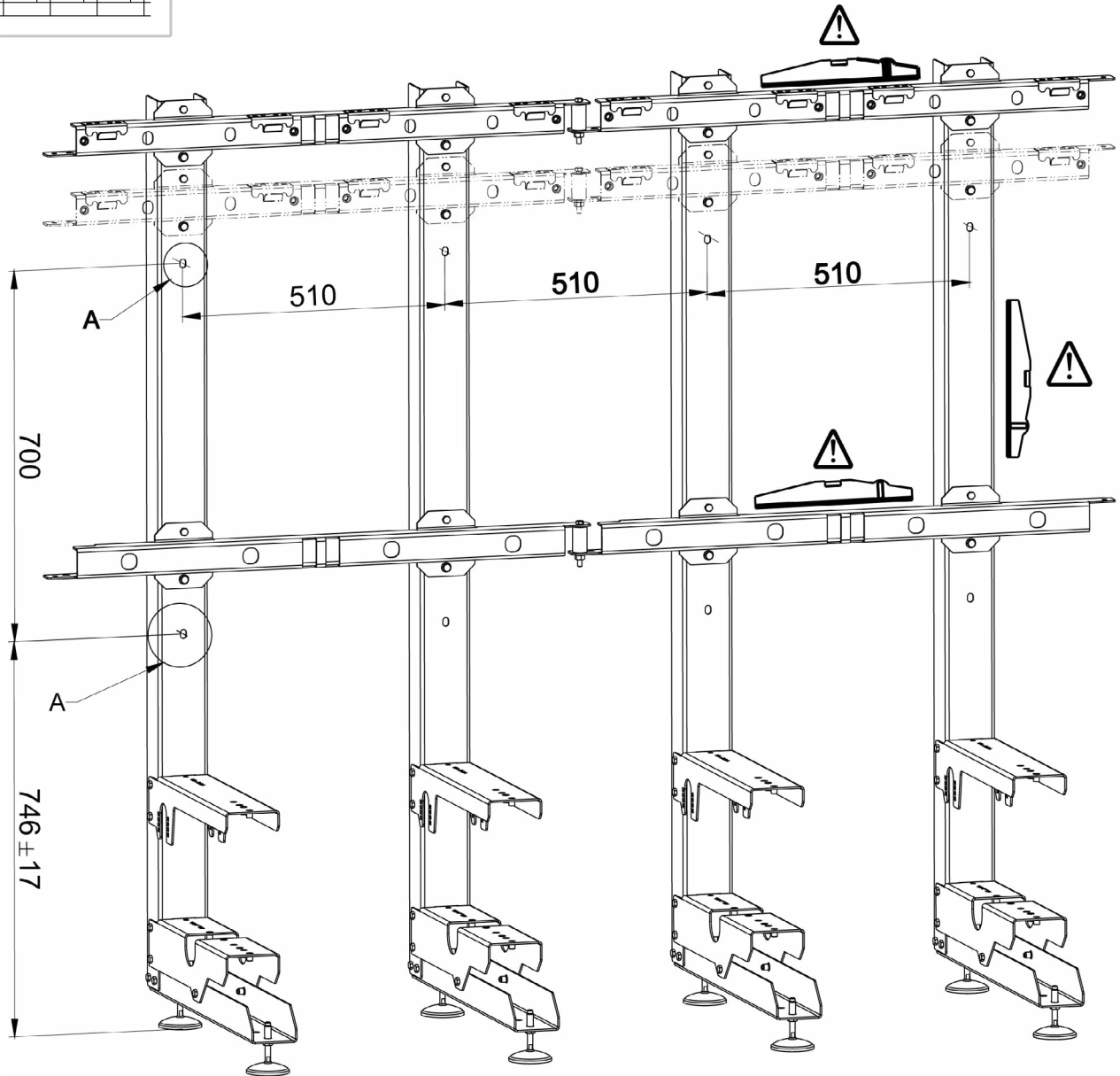
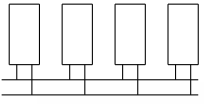

FISSAGGIO
A PARETE

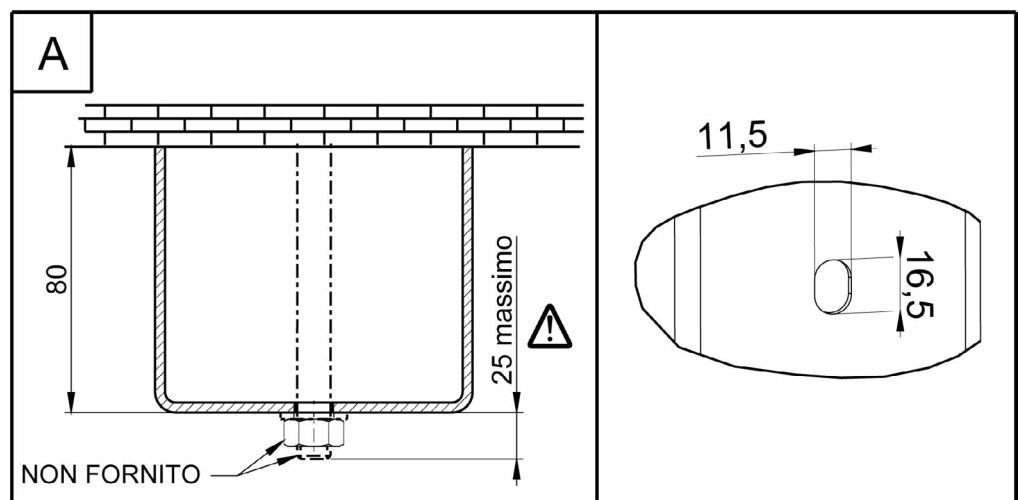

00U07404150-A-F1

4. VALVOLA DI SICUREZZA

4.1. Assemblaggio

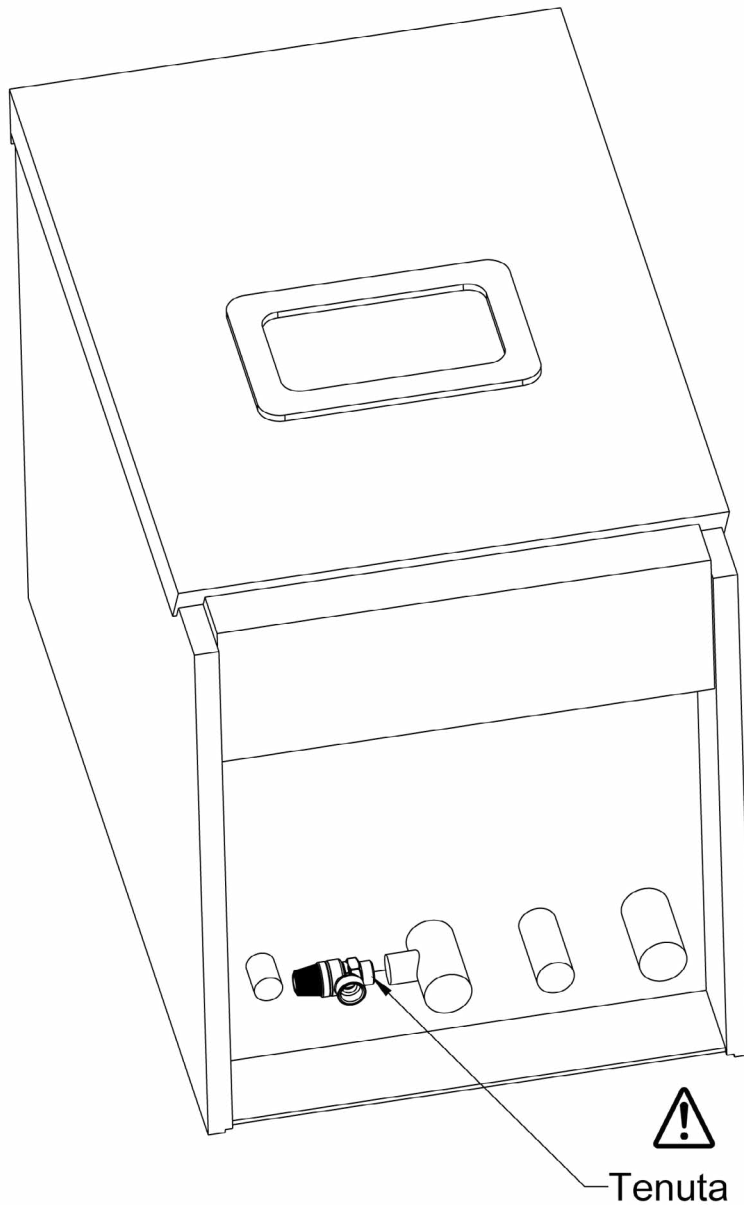
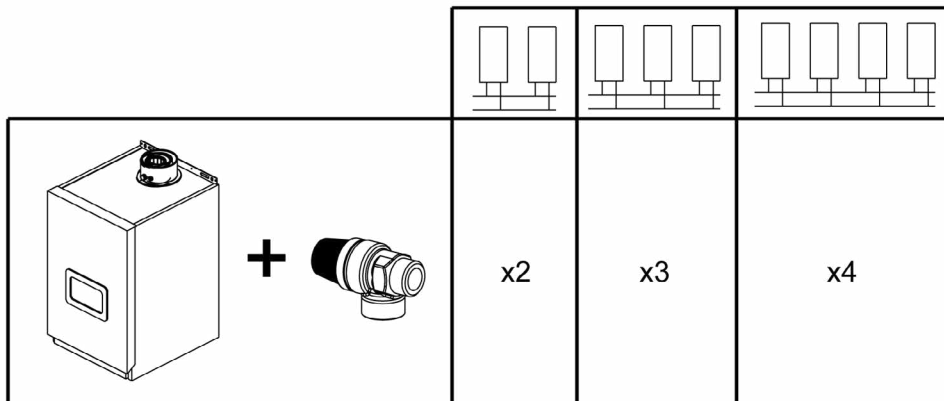

00U07416670-A

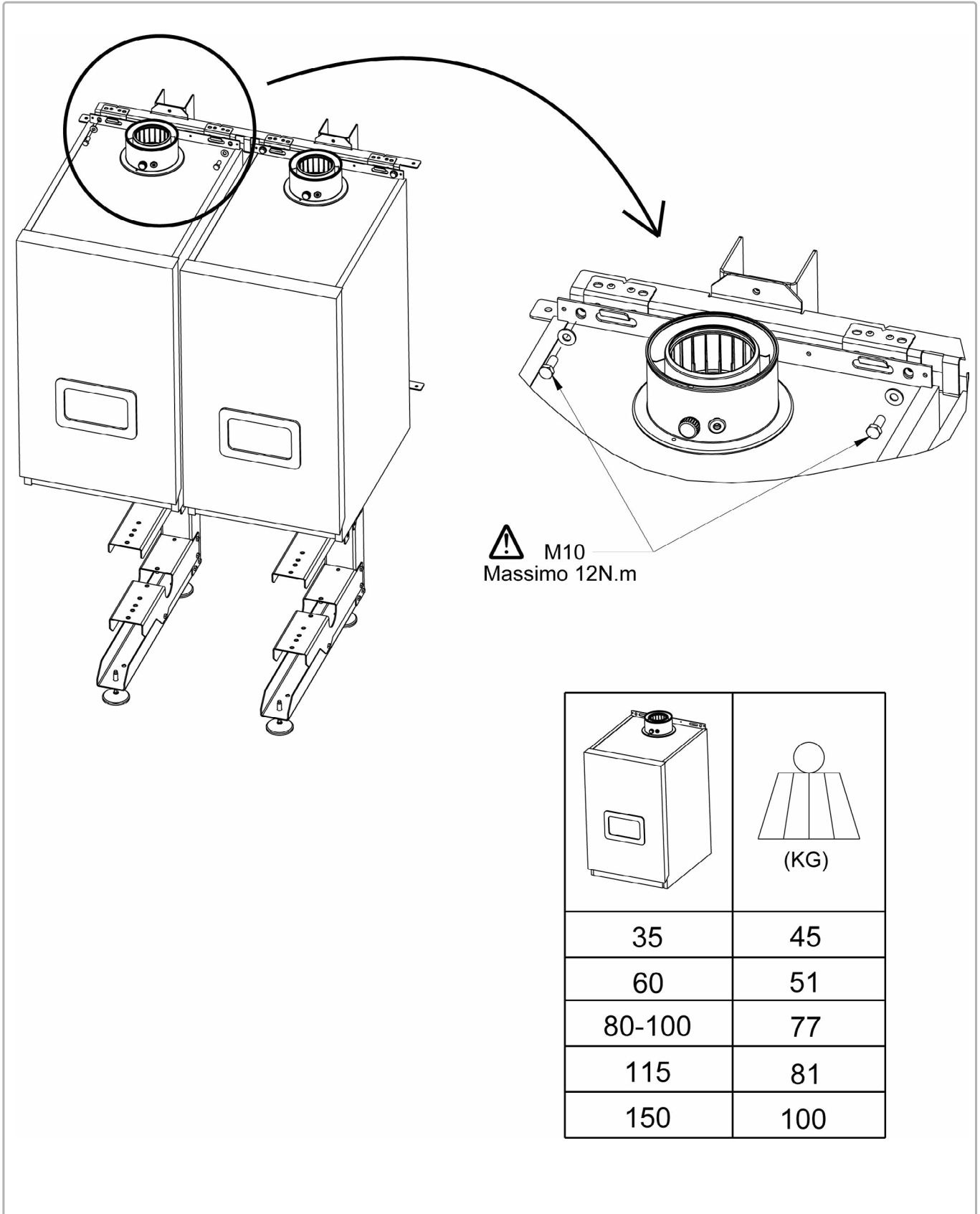

5. CALDAIE SU TELAIO



00U07409740-A

6. TUBI SCARICO CONDENSA

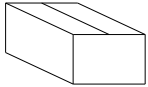
6.1. Elenco dei componenti

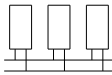
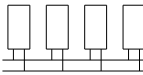
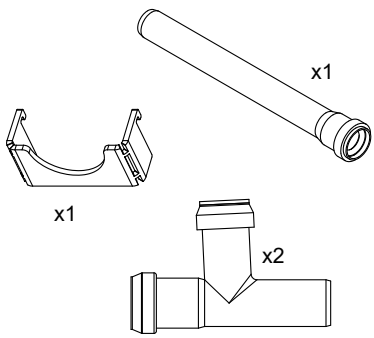
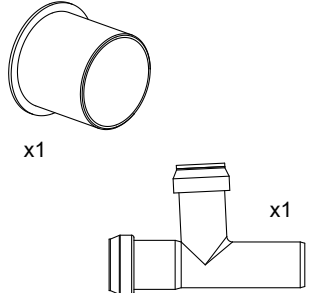
					
082667 082668 082669 082670	 <p>x1</p> <p>x1</p> <p>x2</p>	x2	x3	x4	082667: 35 082668: 60 - 100 082669: 115 082670 : 150
082681	 <p>x1</p> <p>x1</p>	x1			35 a 150
082682			x1		
082683				x1	

6.2. Assemblaggio

Se il raccordo alla fognatura si trova a destra del kit, l'orientamento e la pendenza del collettore vanno invertiti in confronto alle immagini di fianco.

Se il raccordo alla fognatura e lo scarico dei fumi si trovano dallo stesso lato del kit, nelle raffigurazioni seguenti è necessario montare il raccordo a T più a sinistra, opposto al collettore (subito prima del tappo).

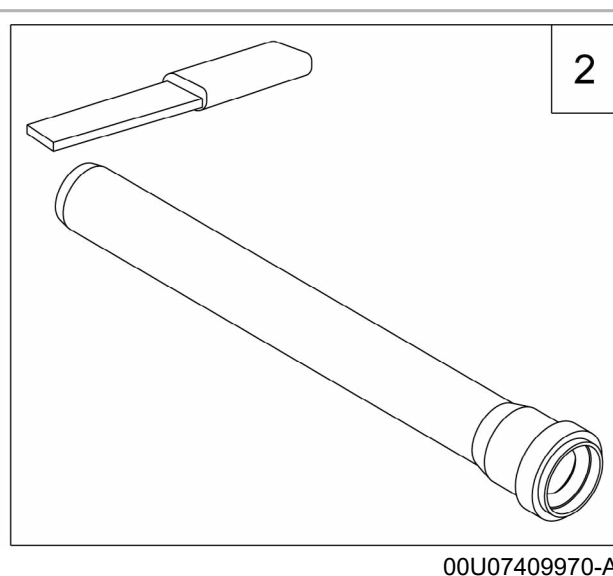
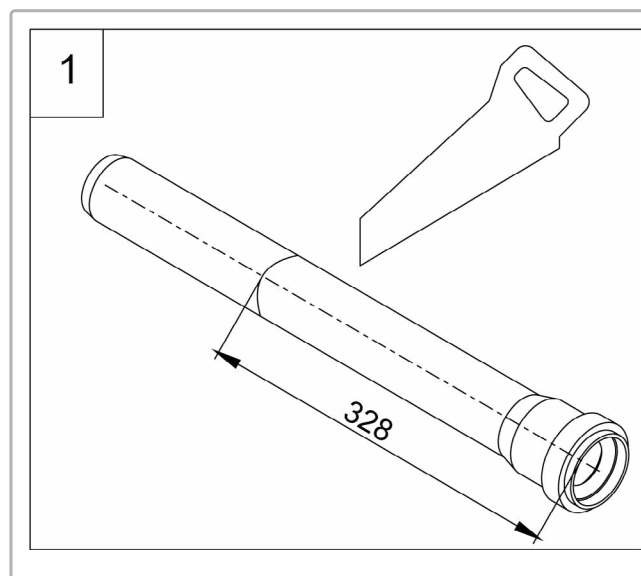
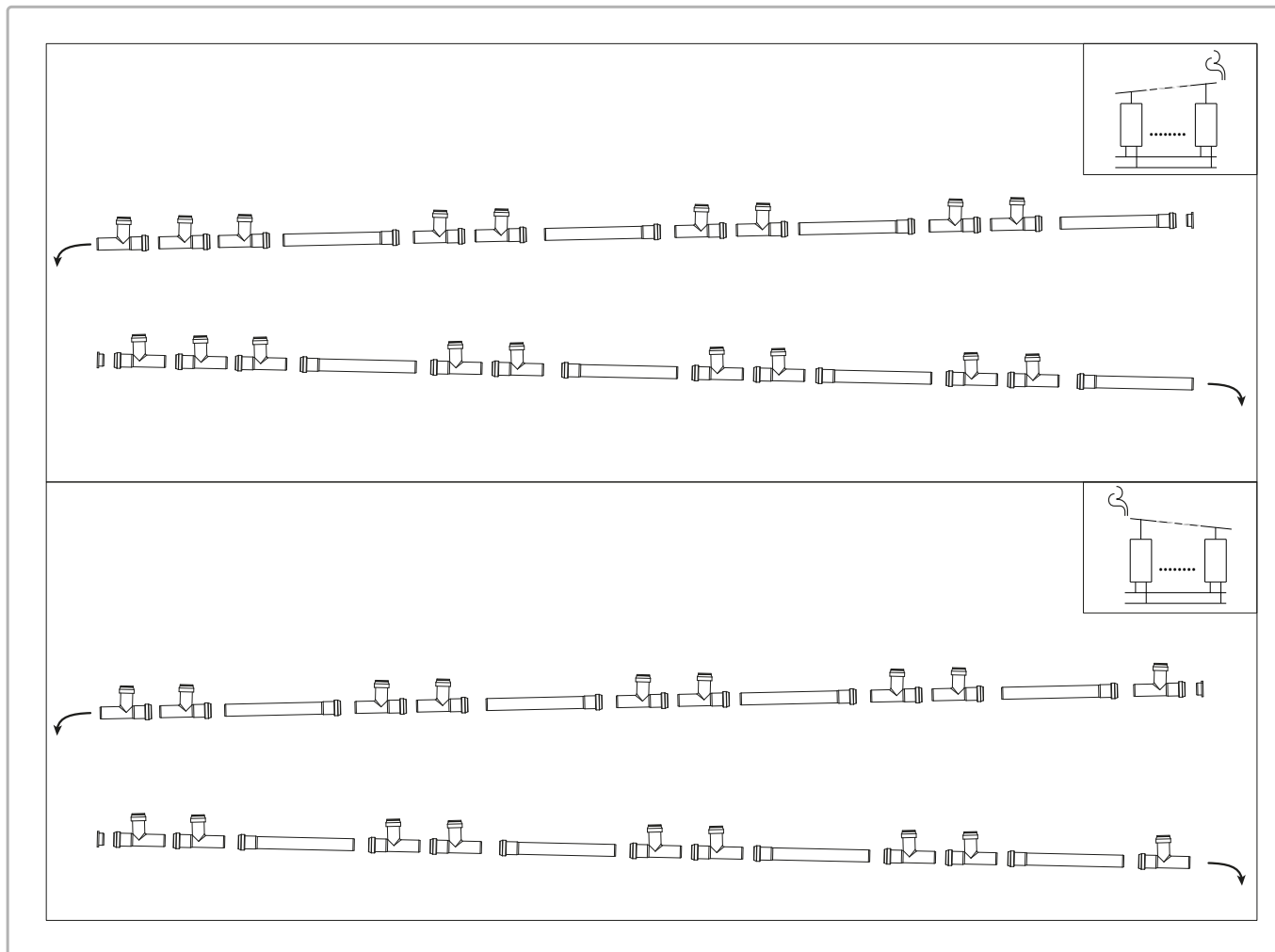

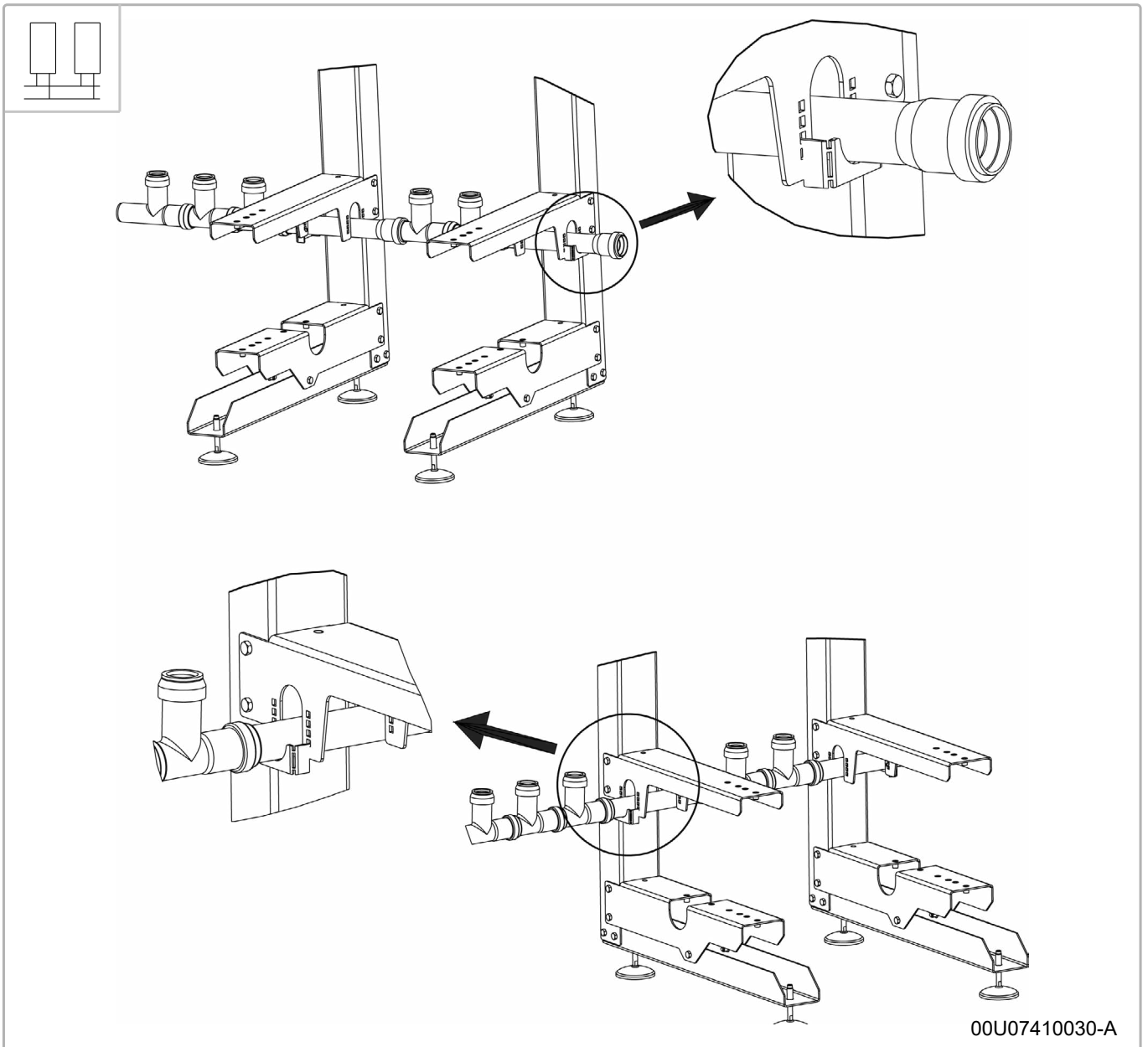
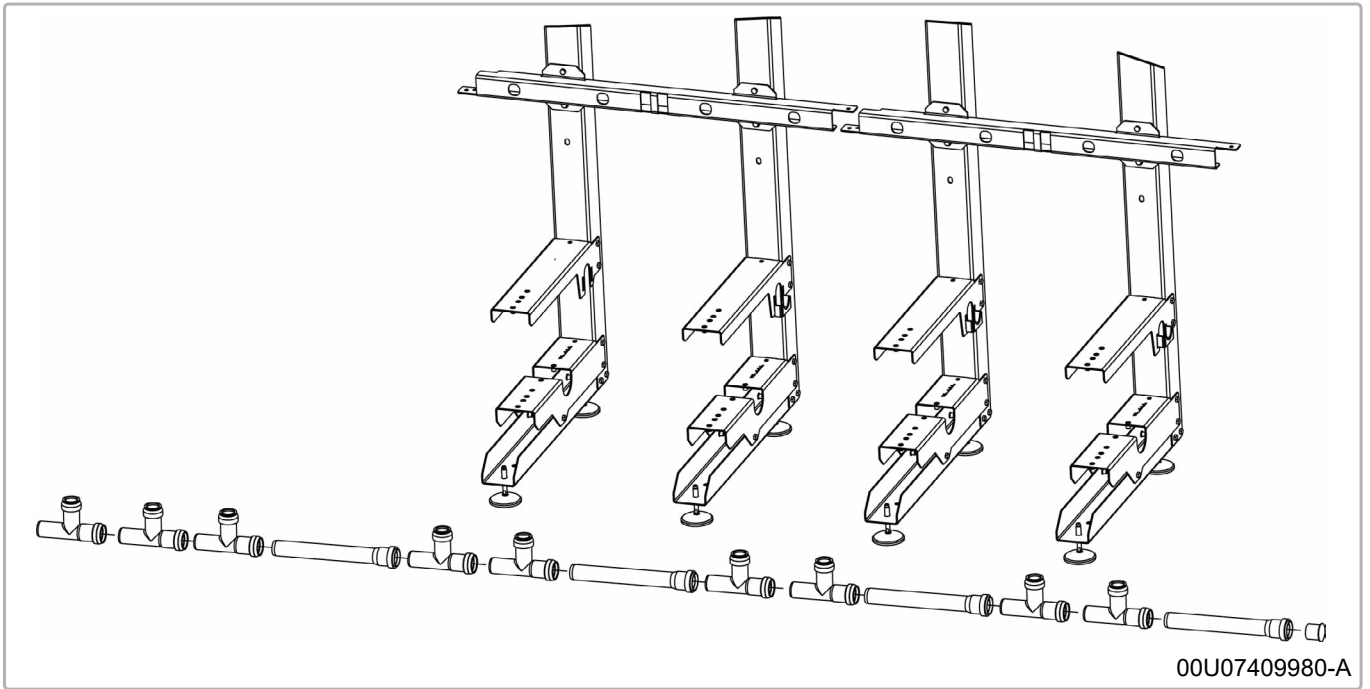

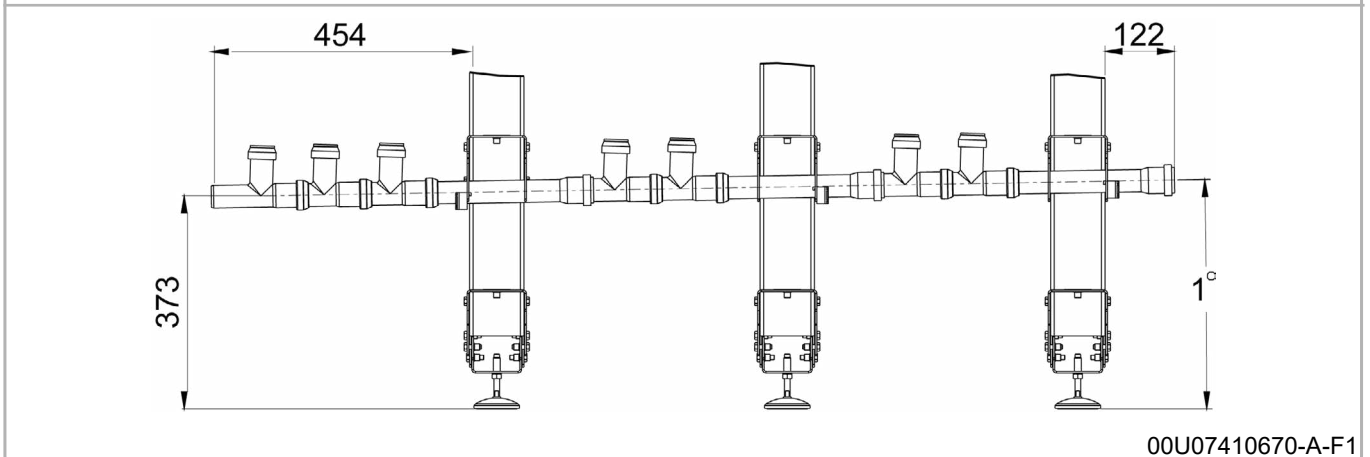
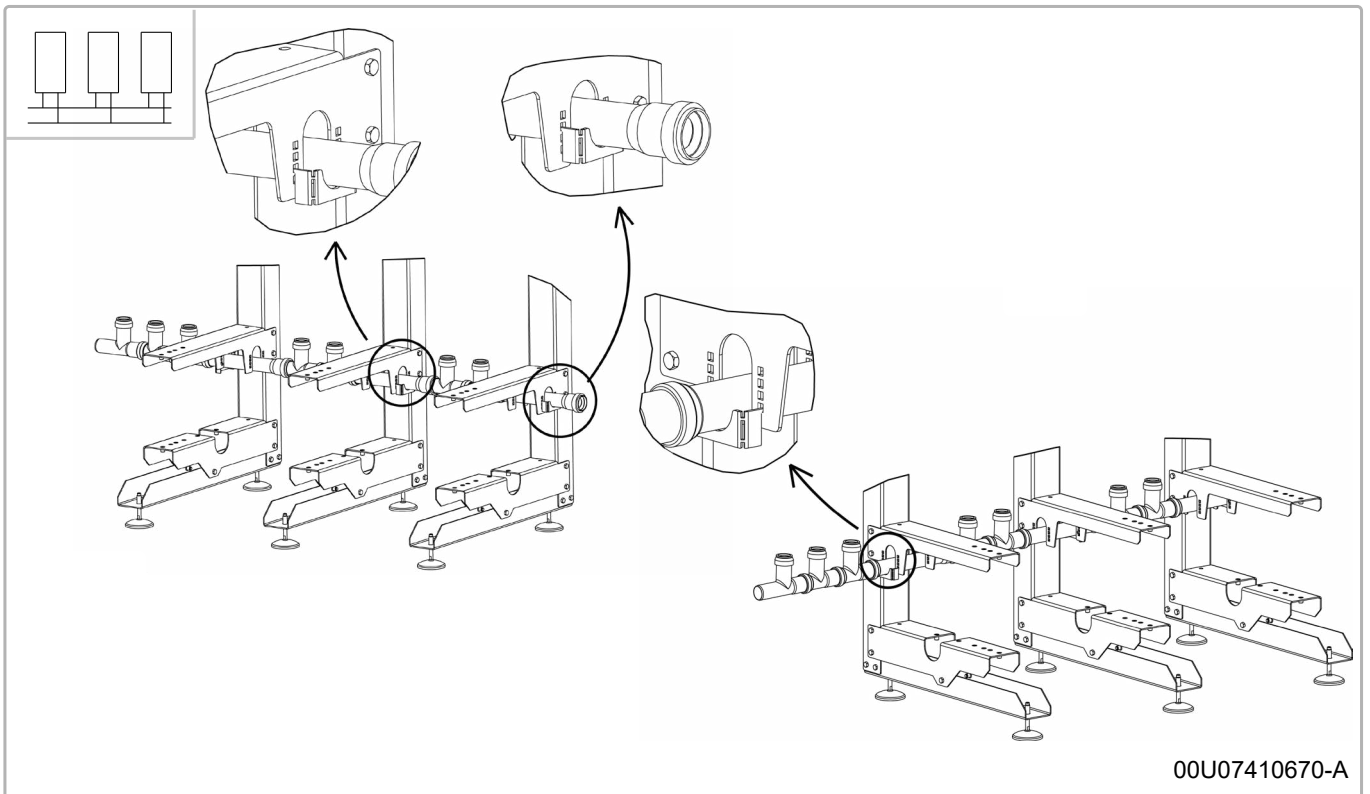
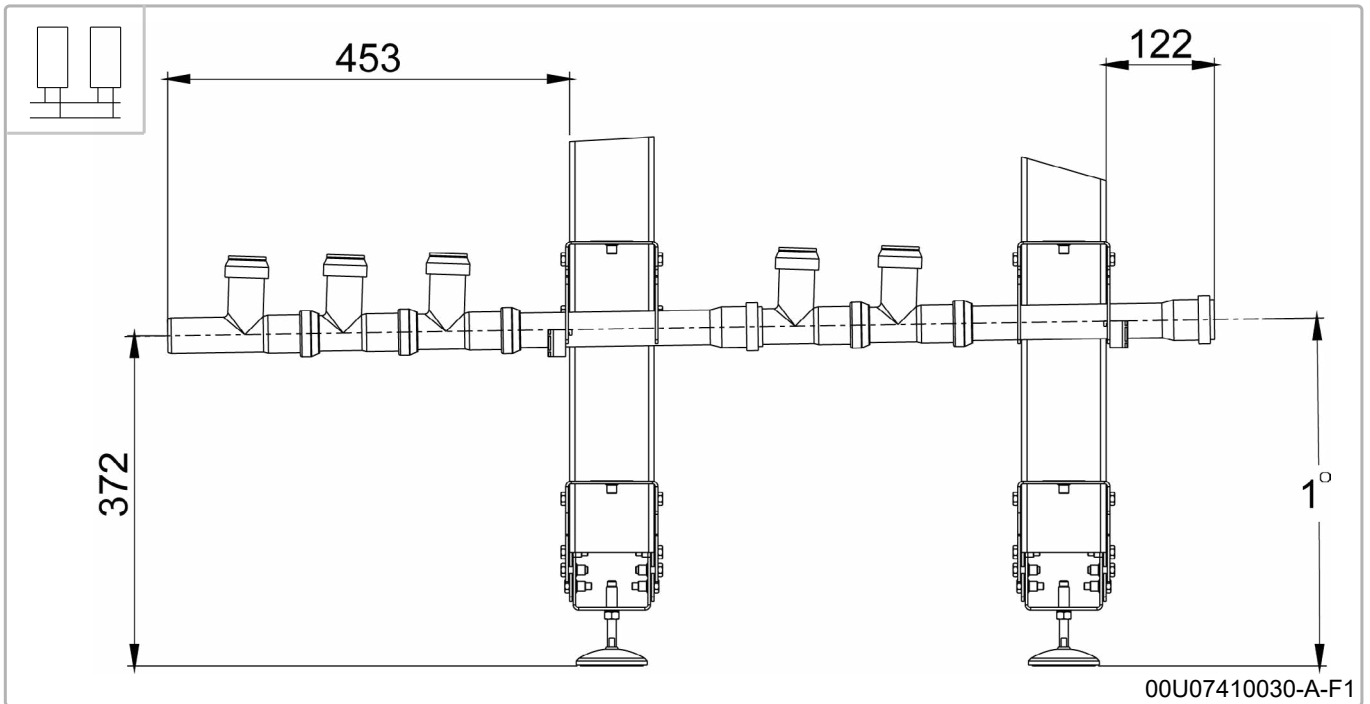

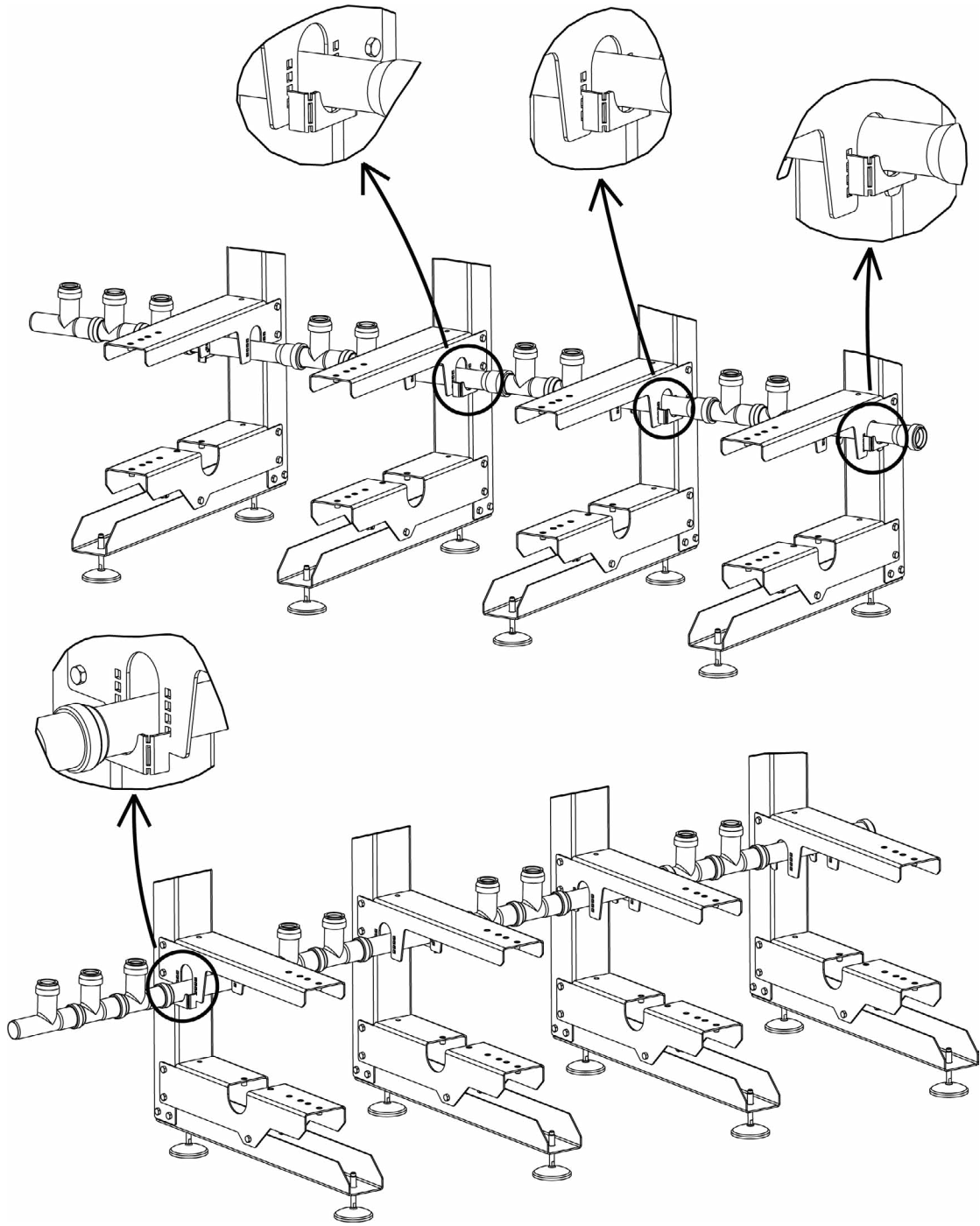



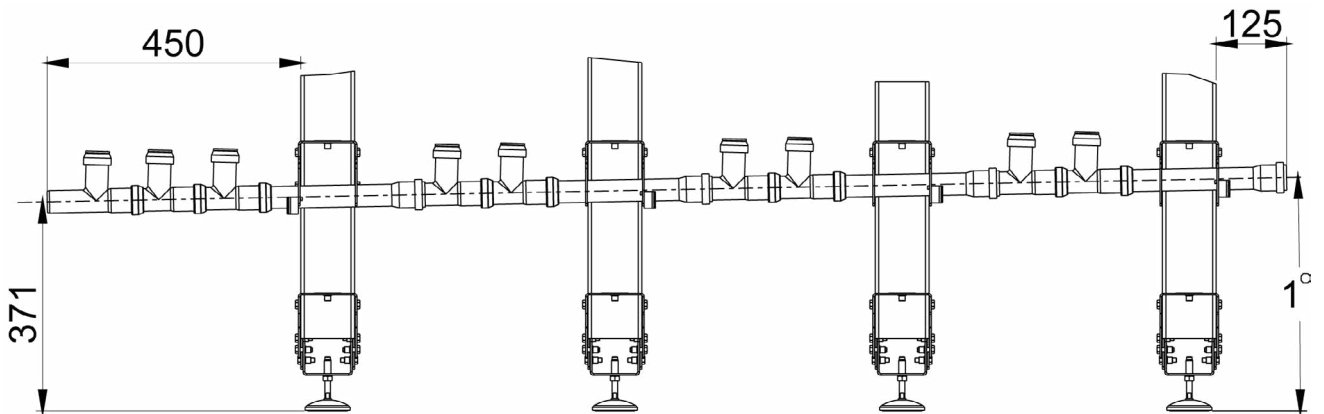







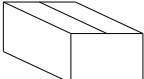

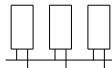
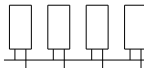
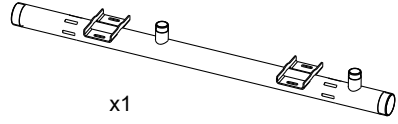
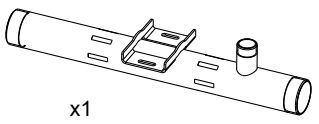

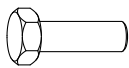
00U07411380-A

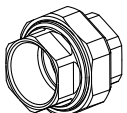

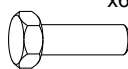
00U07411380-A-F1

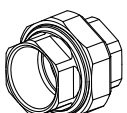
7. COLLETTORE GAS

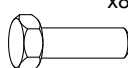
7.1. Elenco dei componenti

				
082712	 x1	x1	x1	x2
082713	 x1		x1	
082675	 x1  x4  x4	x1		
082676	 x1  x1  x6  x6		x1	
082677	 x1  x1  x8  x8			x1

7.2. Assemblaggio



Il tappo può essere montato a sinistra o a destra del collettore del gas a seconda del lato di arrivo del gas.

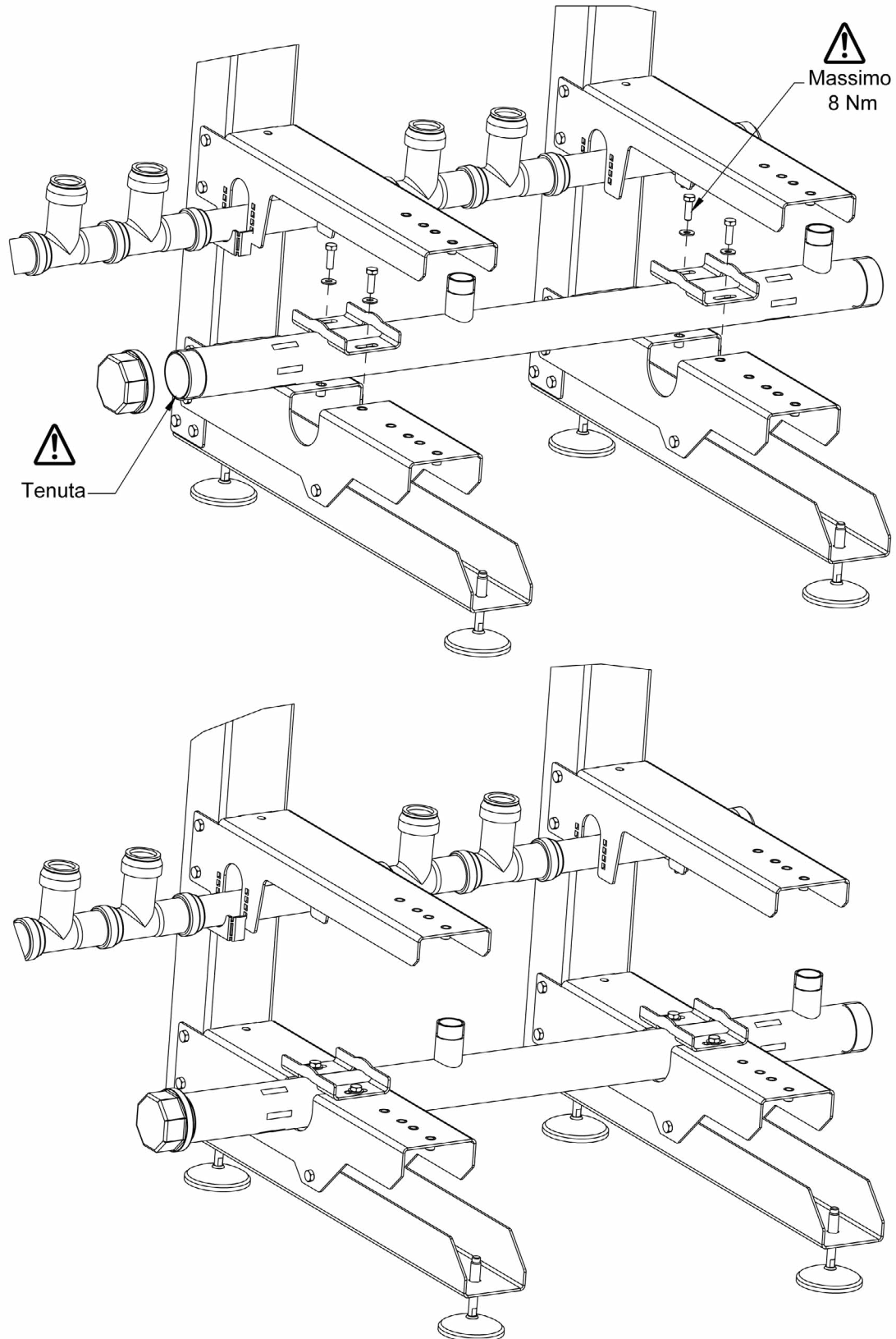

00U07412460-A

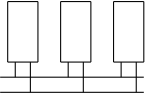

Il tappo può essere montato a sinistra o a destra del collettore del gas a seconda del lato di arrivo del gas.

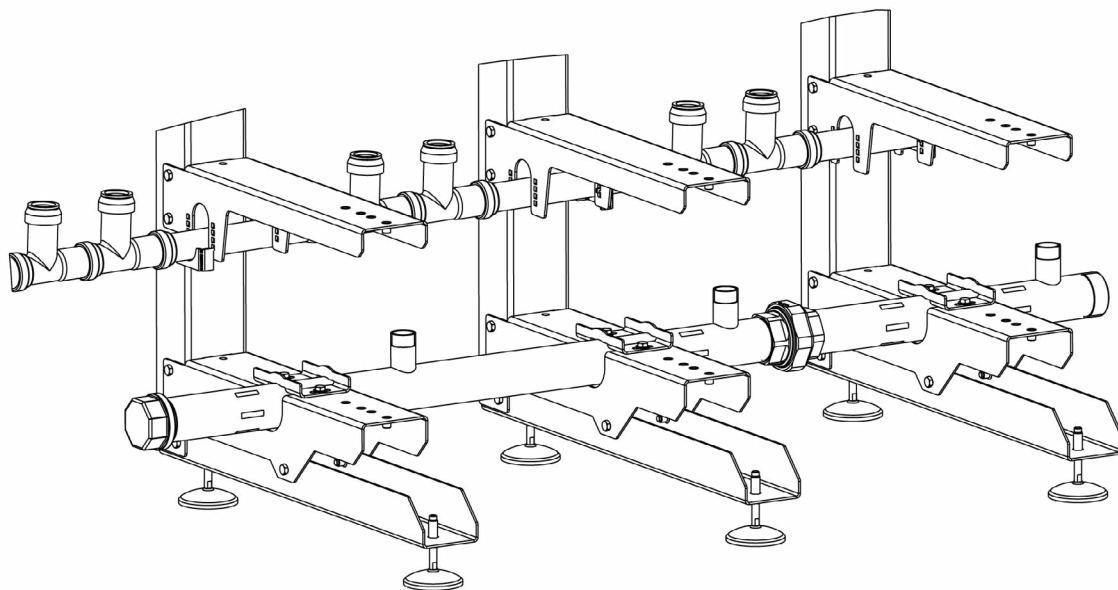
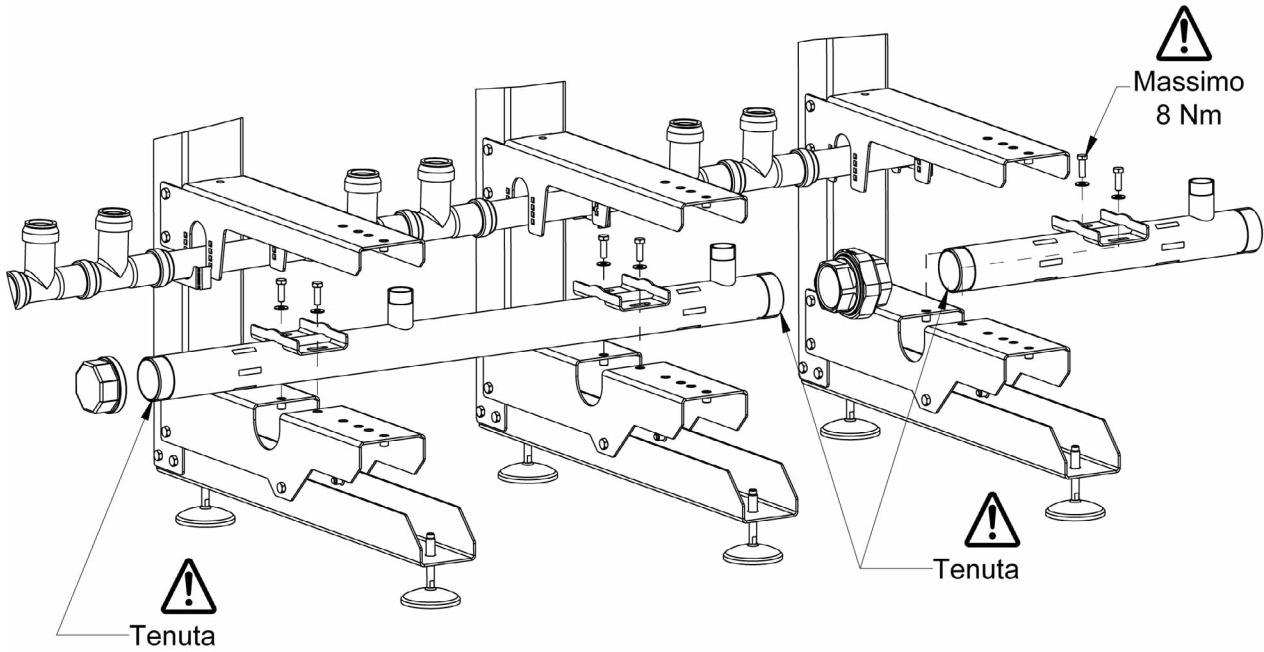

00U07412470-A

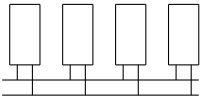



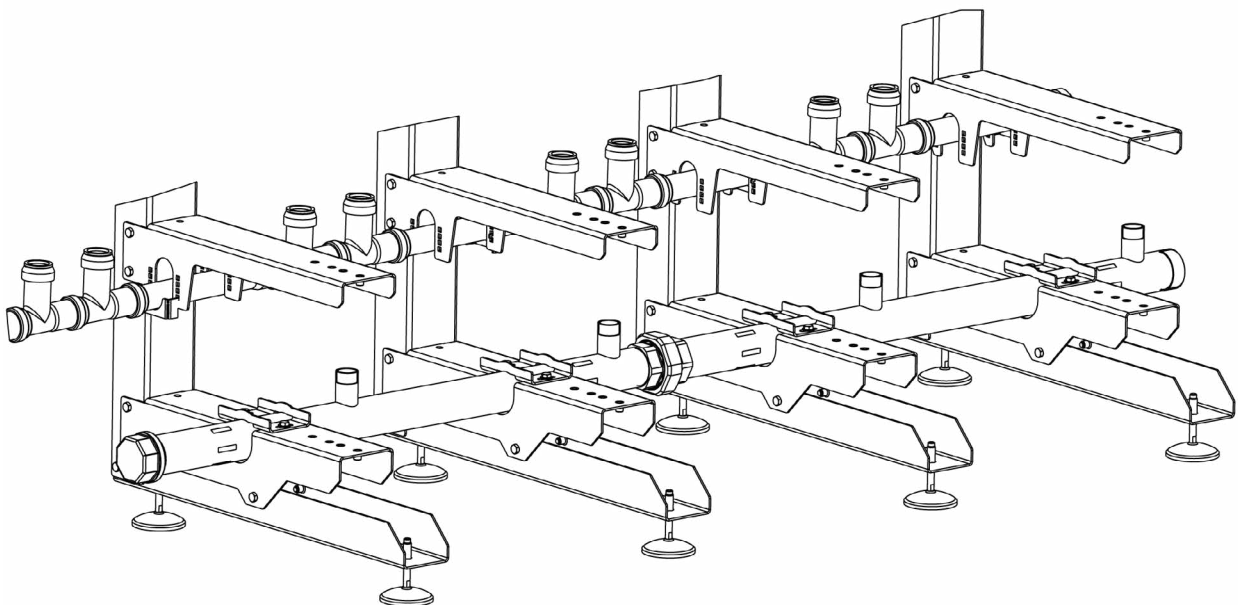
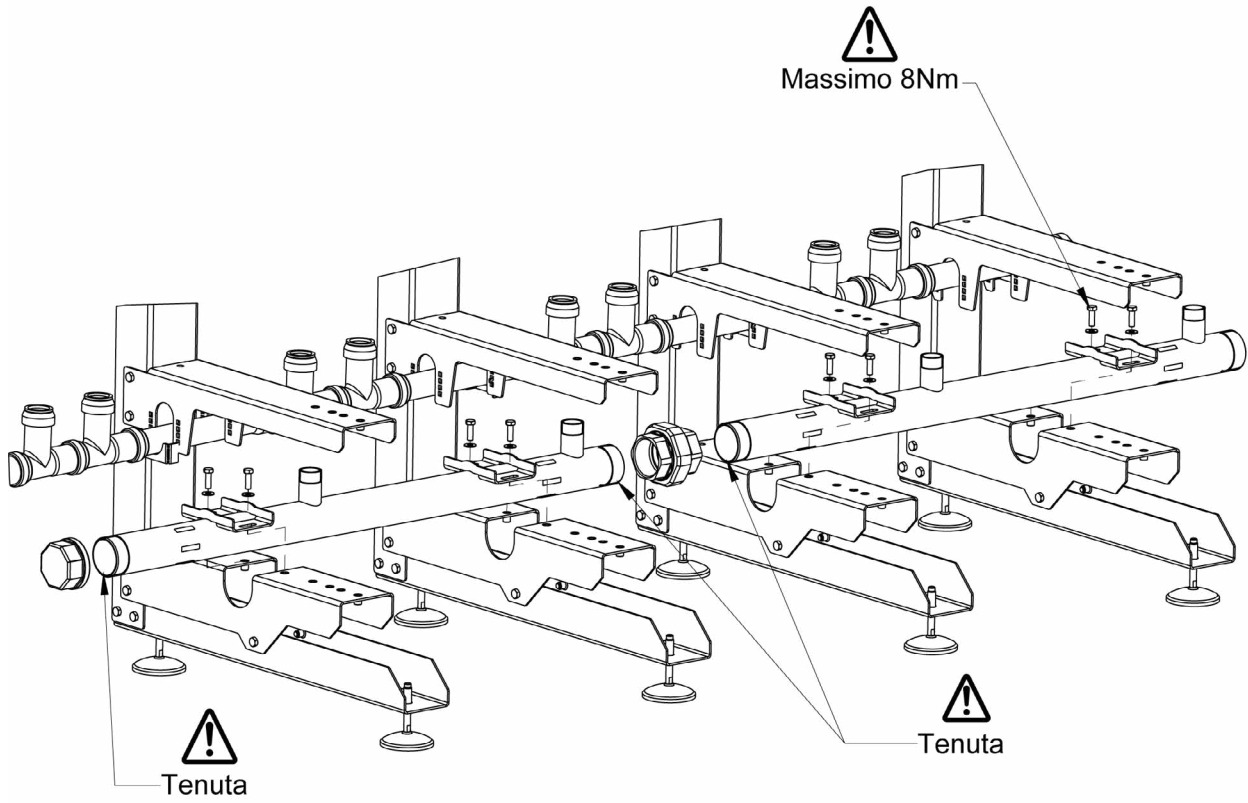





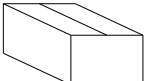

Il tappo può essere montato a sinistra o a destra del collettore del gas a seconda del lato di arrivo del gas.

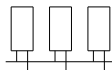
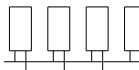
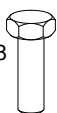

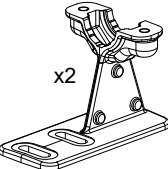
00U07412480-A

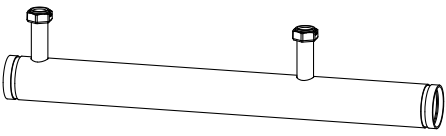
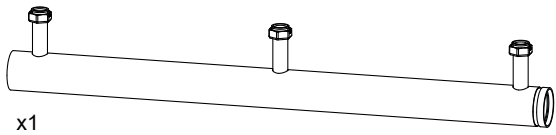
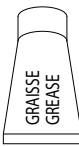
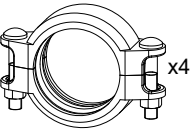
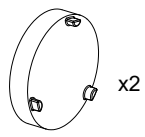
8. COLLETTORE IDRAULICO

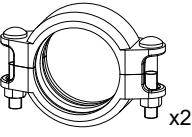
8.1. Elenco dei componenti

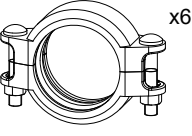
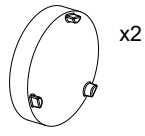
				
083377	 M8 x4  x4  x2  x2	x2	x3	x4
082710	 x1	x2		x4
082711	 x1		x2	
082681	 x1  x4  x2	x1		
082682	 x1  x2		x1	
082683	 x1  x6  x2			x1



Stringere molto moderatamente le viti. Verranno strette dopo il posizionamento del boiler (idraulico).

Se il boiler è montato a destra del kit, l'orientamento dei collettori deve essere invertito in confronto alle immagini di fianco:

DUO: grande lato del collettore a sinistra

TRIO: lato otturato a sinistra

QUATTRO: il lato grande al centro della cascata

8.2. Assemblaggio cascata Duo

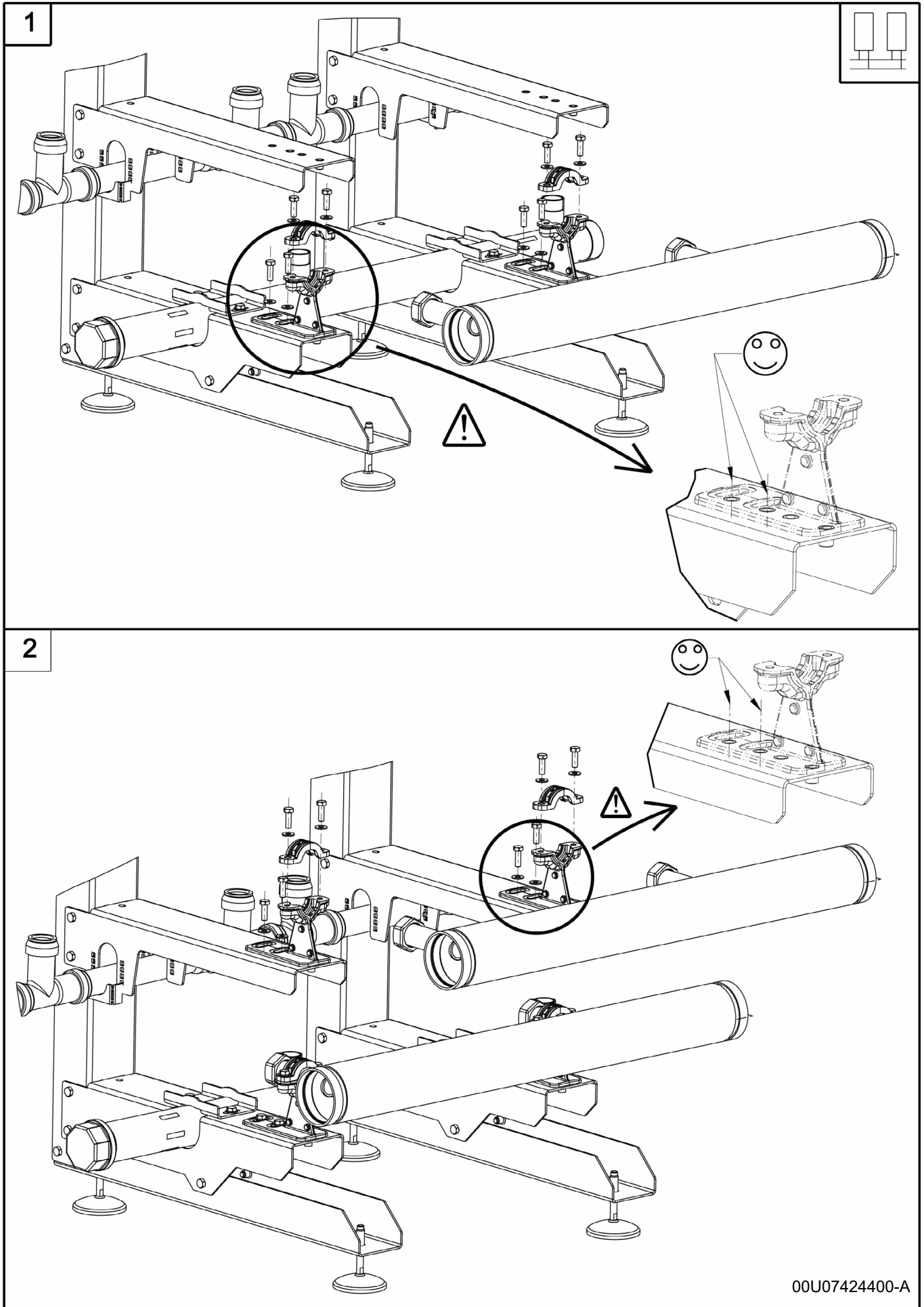

3

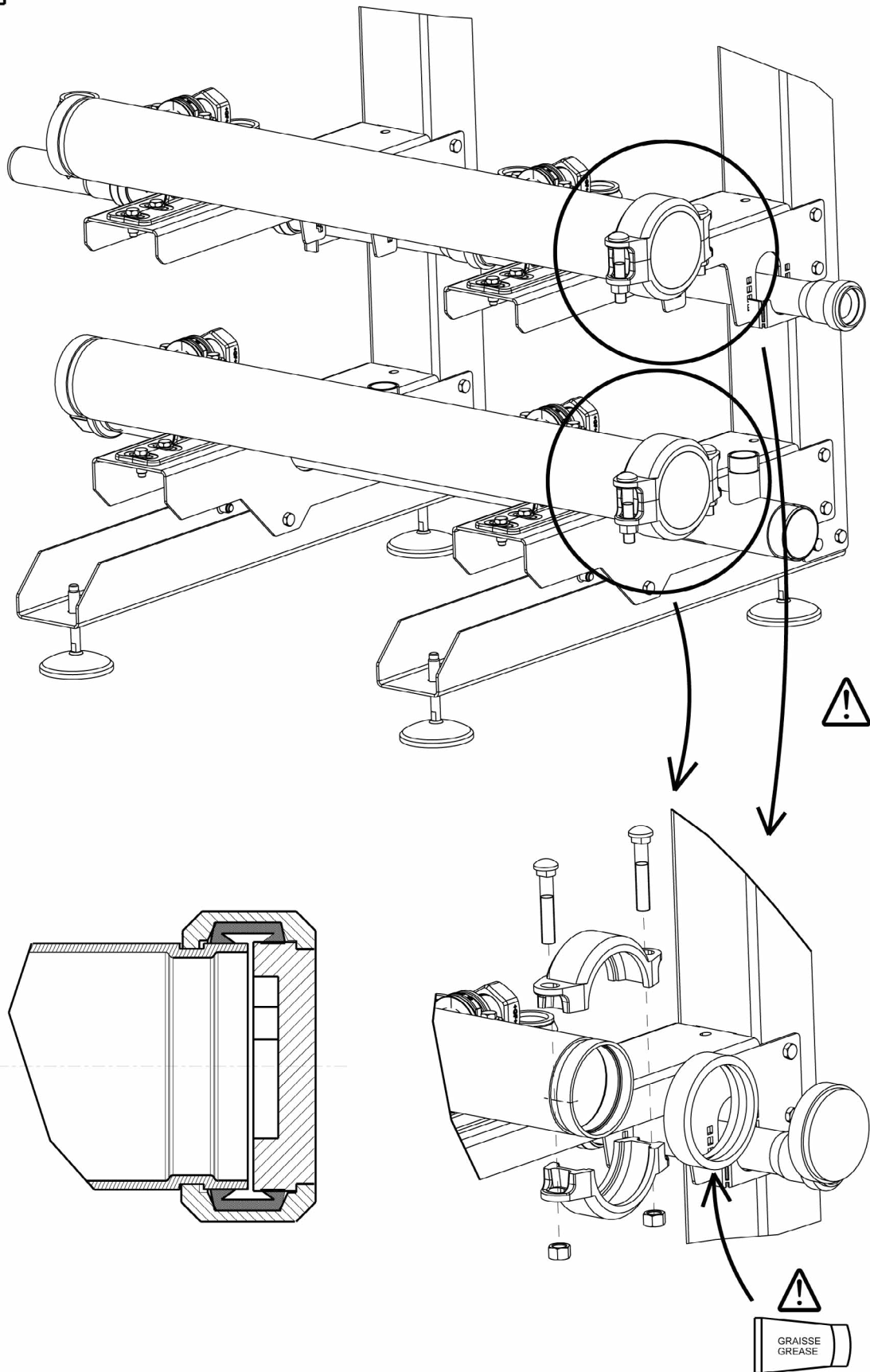
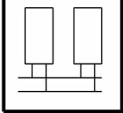

00U07412800-A

3a

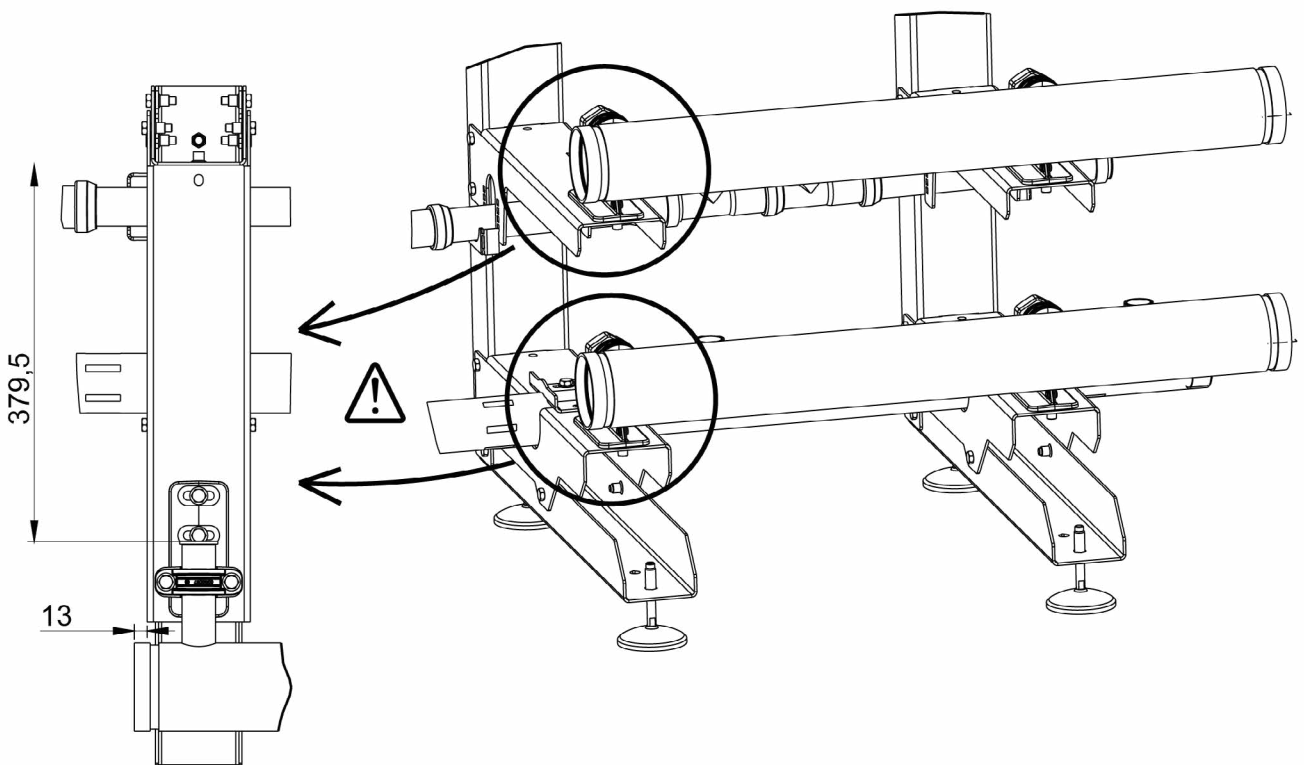
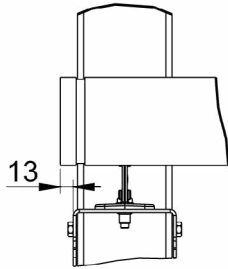
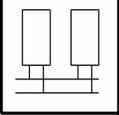

00U07424400-A-F1

8.3. Assemblaggio cascata Trio

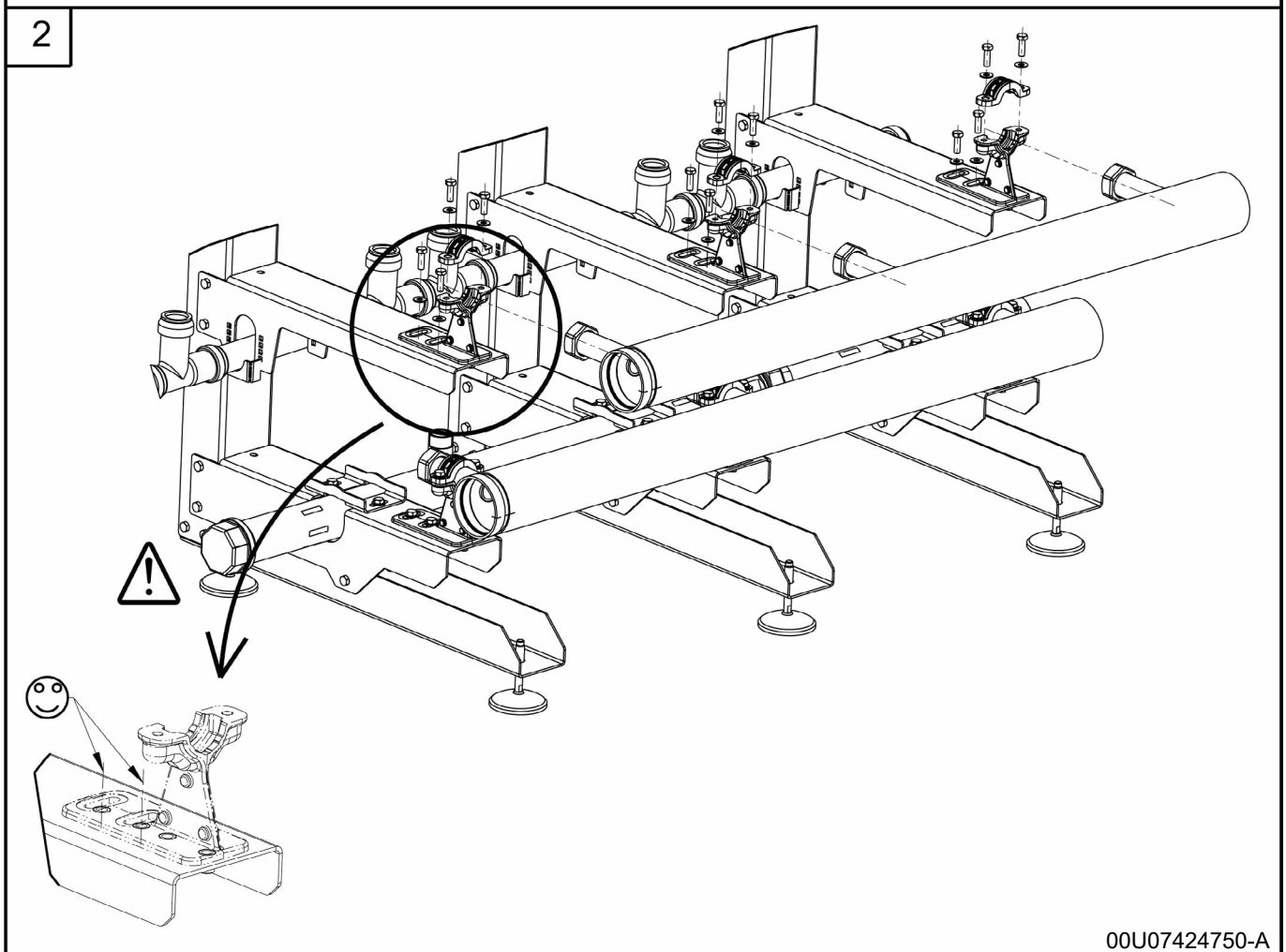
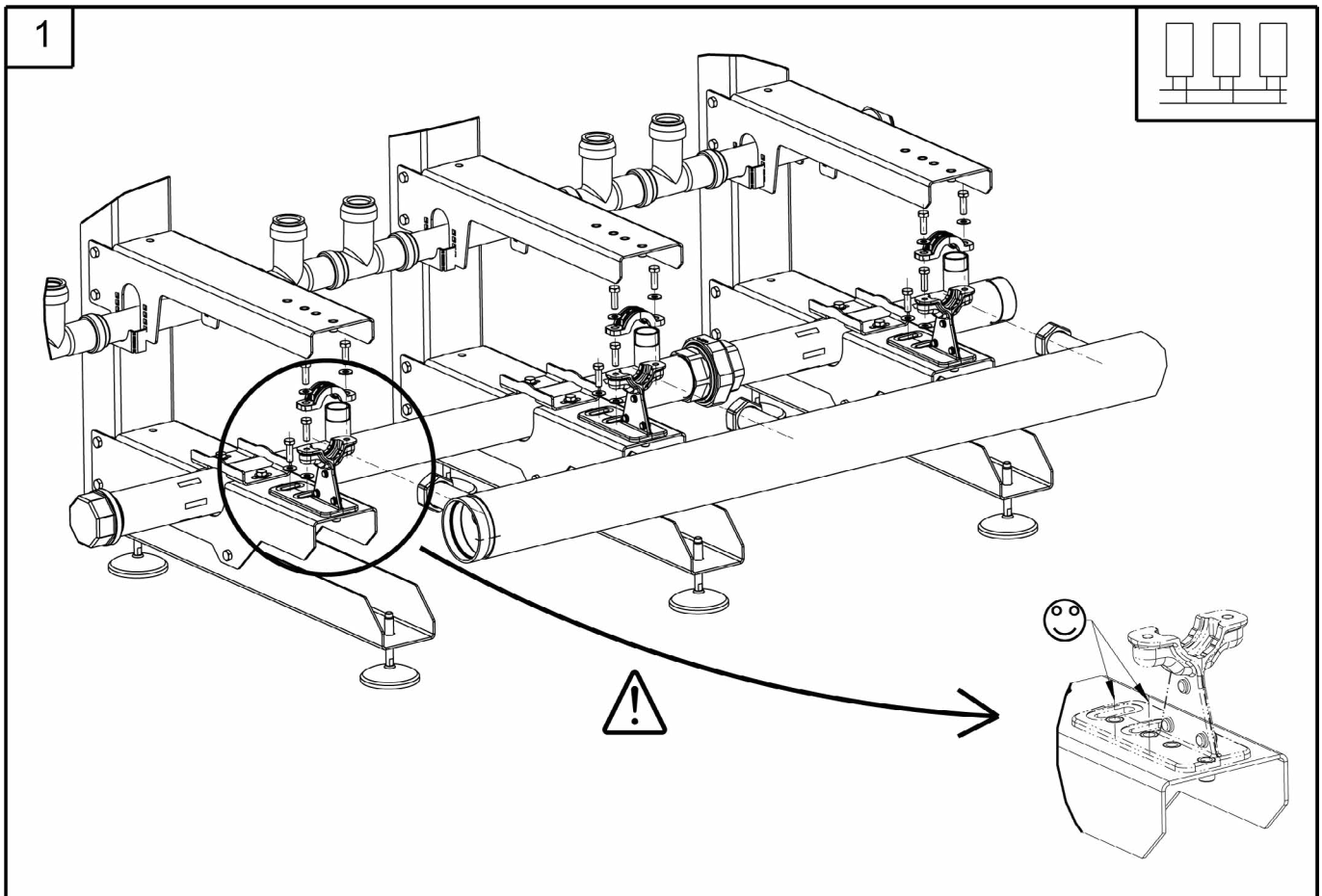

00U07424750-A

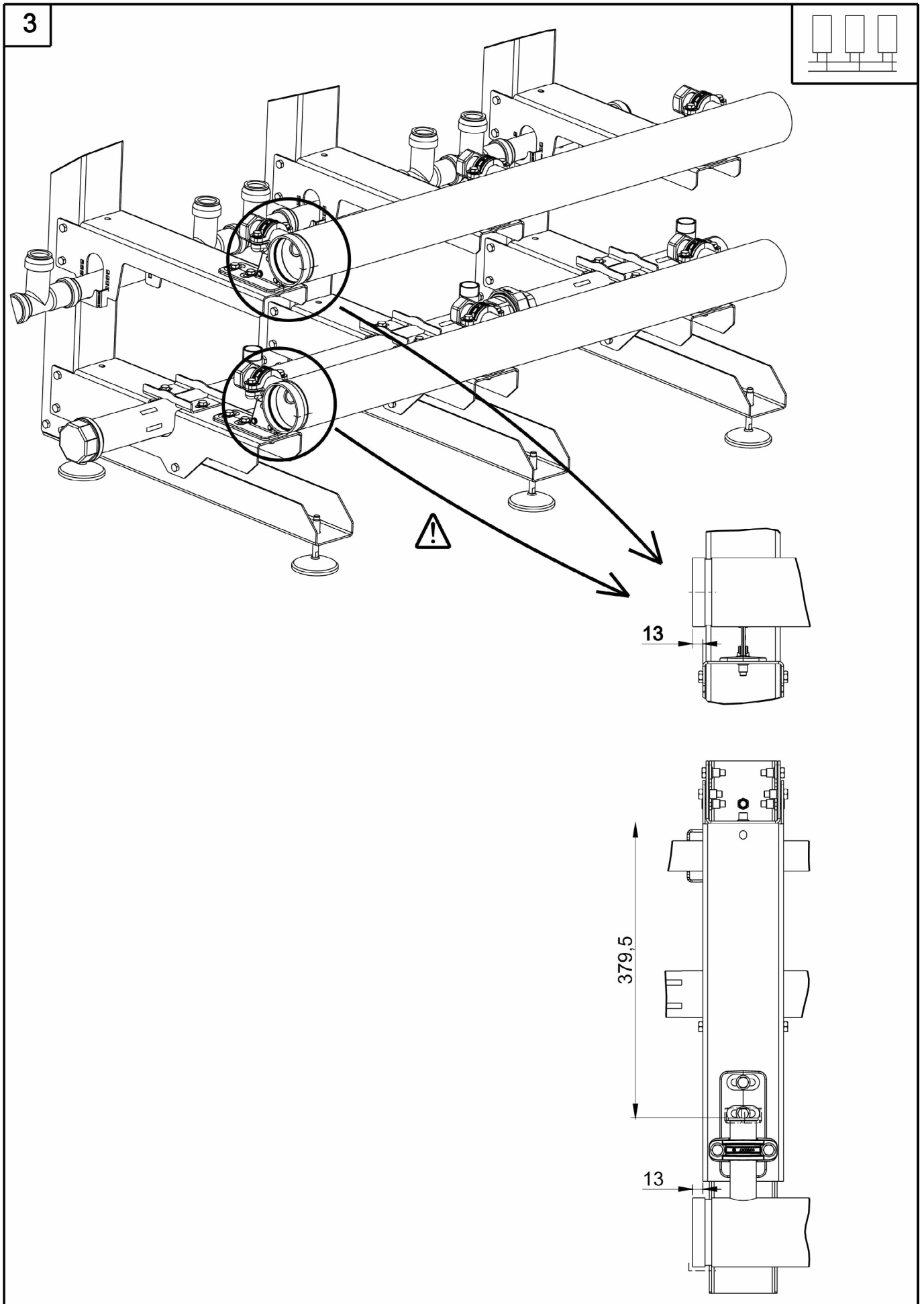

00U07424750-A-F1

8.4. Assemblaggio cascata Quattro

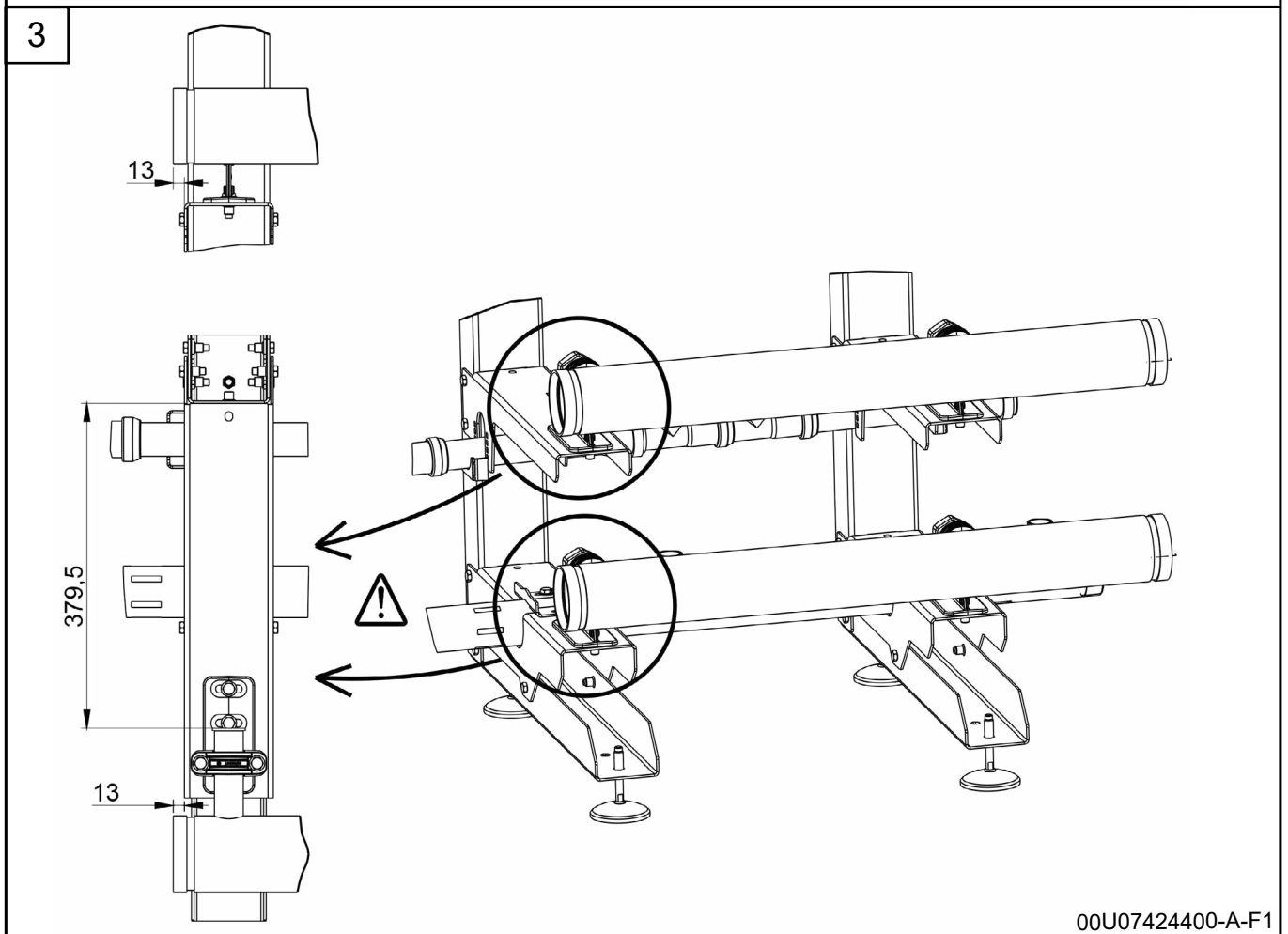
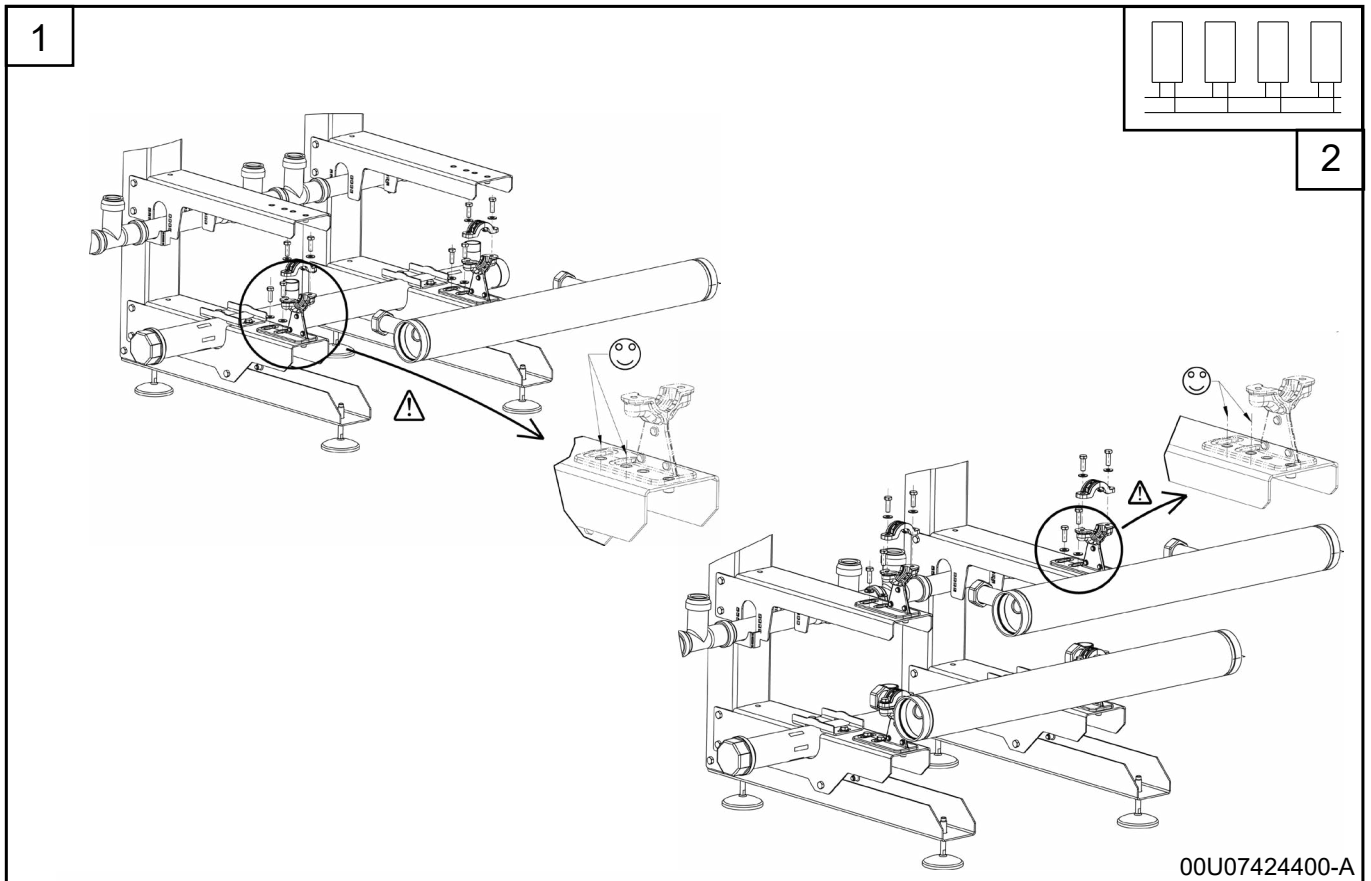

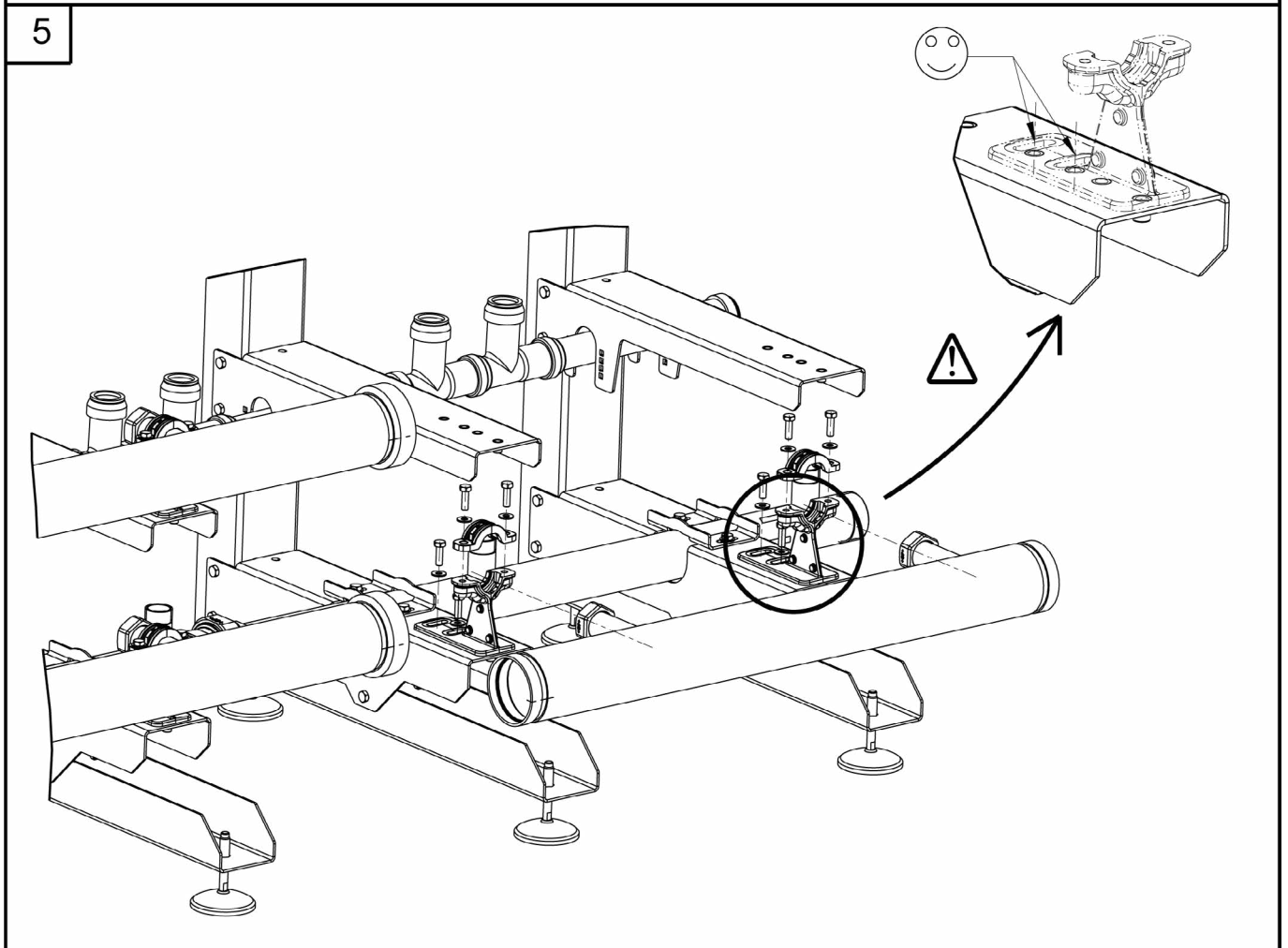
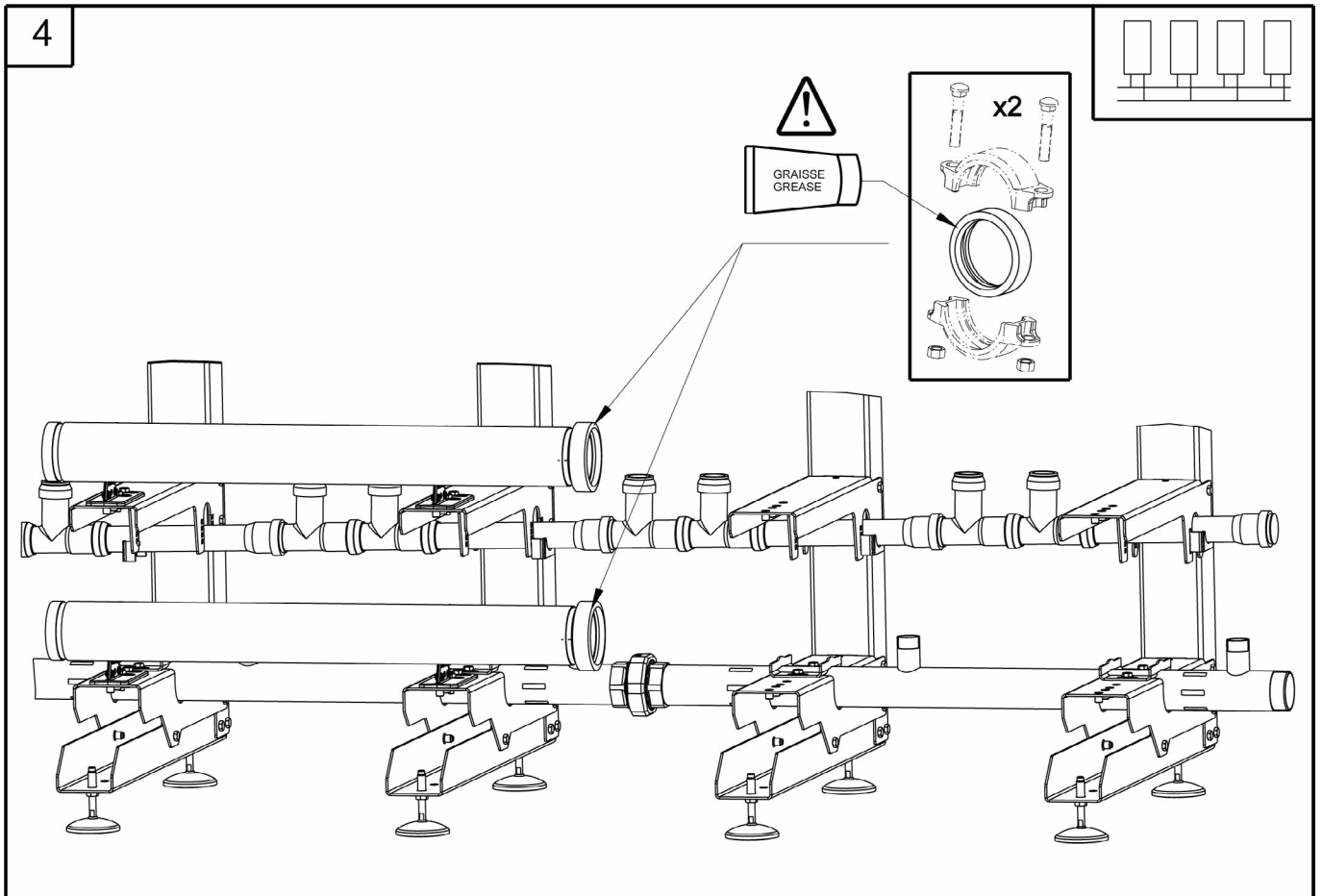

00U07425060-A

6

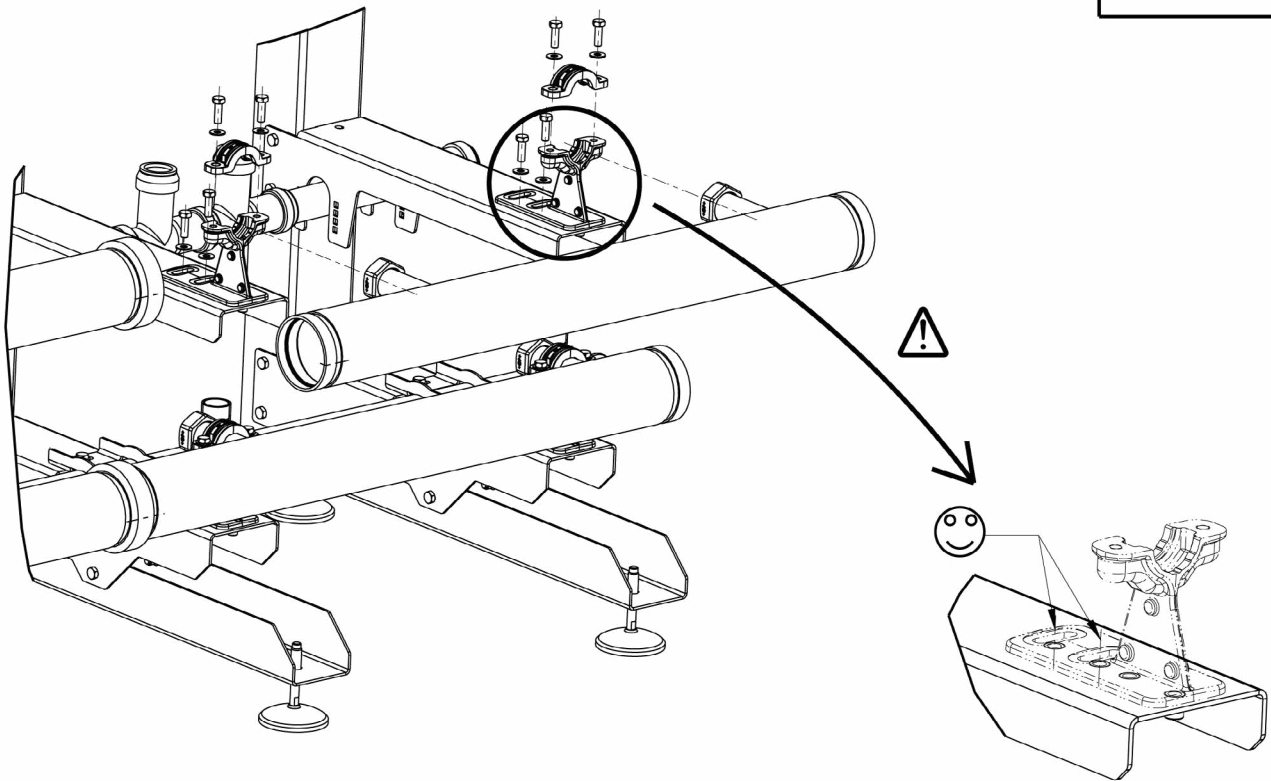
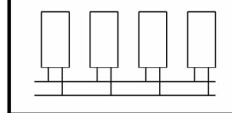

7

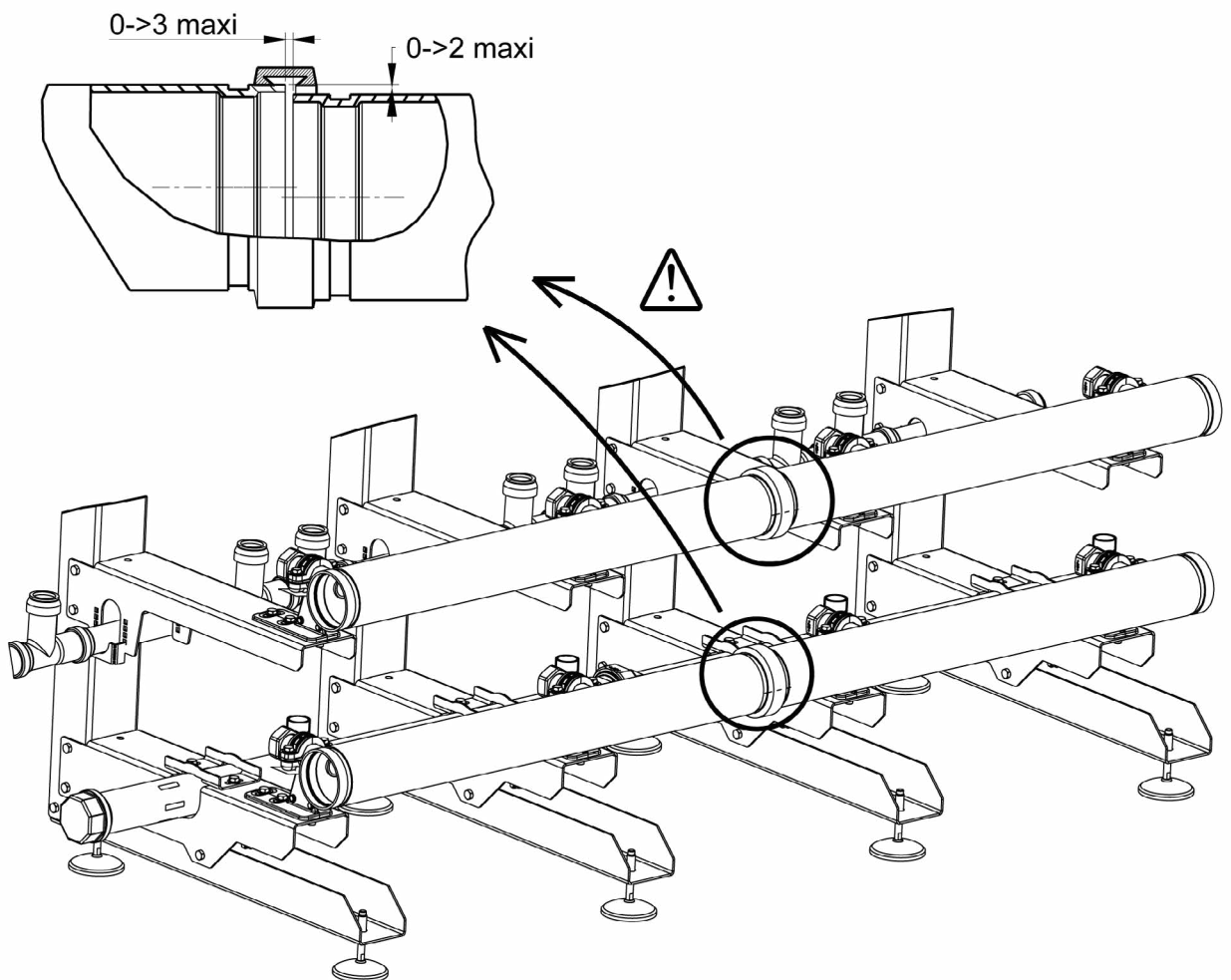

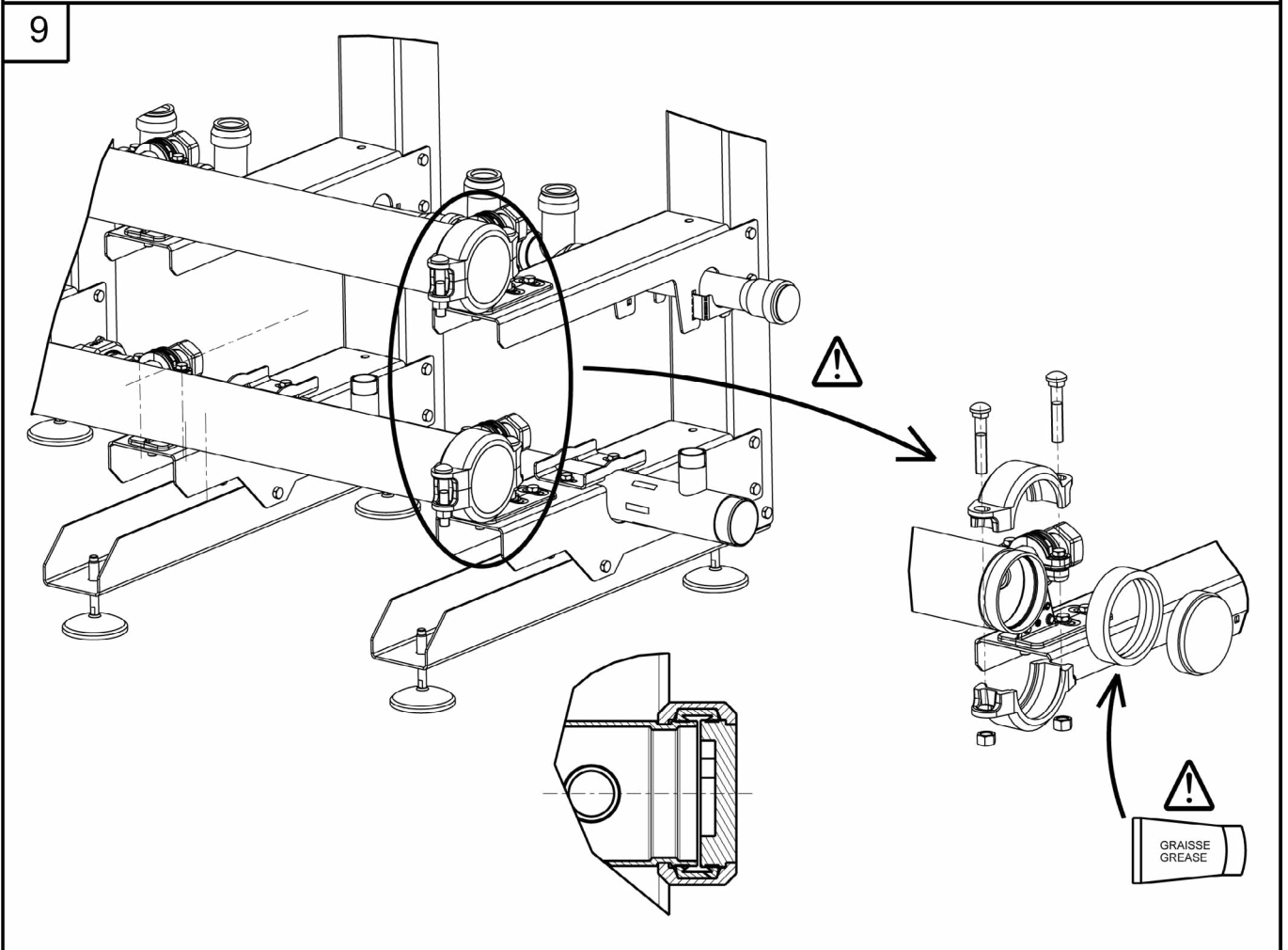
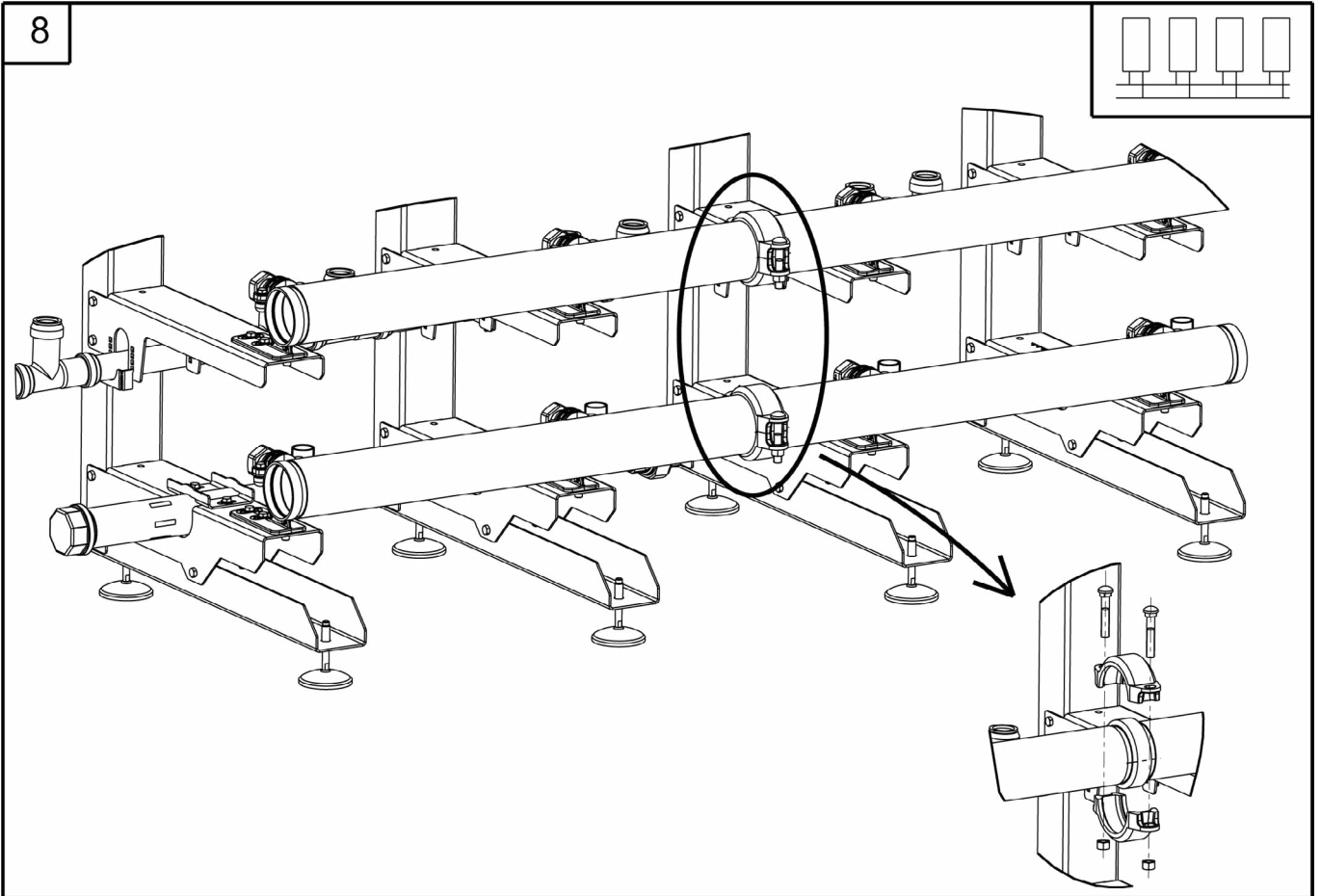

00U07425060-A-F1



00U07431150-A

9. COLLEGAMENTO IDRAULICO CALDAIA

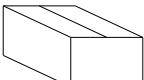
9.1. Elenco dei componenti

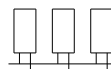
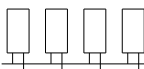
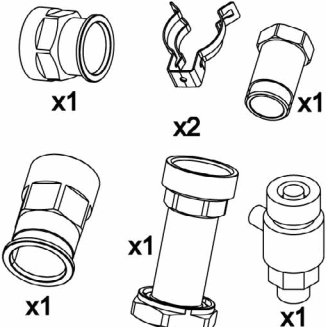
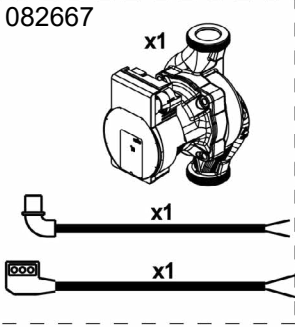
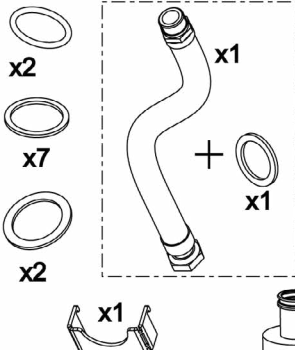
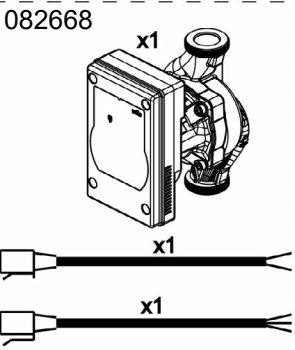
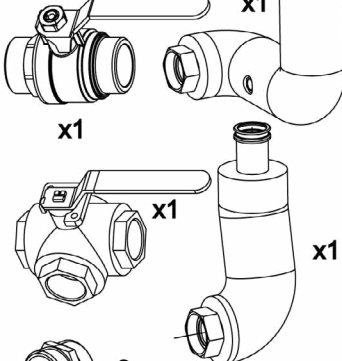
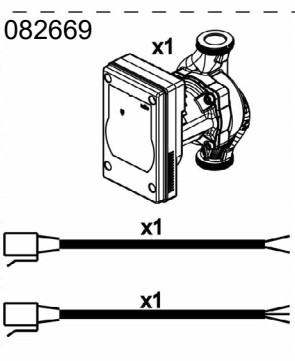
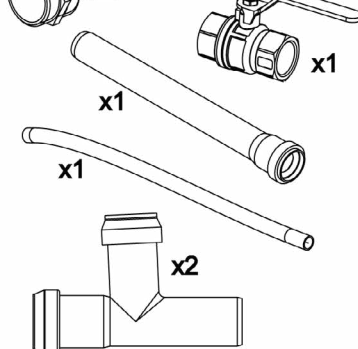
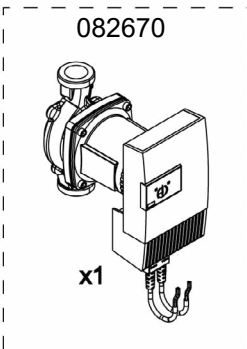
						
082667			x2	x3	x4	35
082668			x2	x3	x4	60 80 100
082669			x2	x3	x4	115
082670			x2	x3	x4	150

00U07398820-A

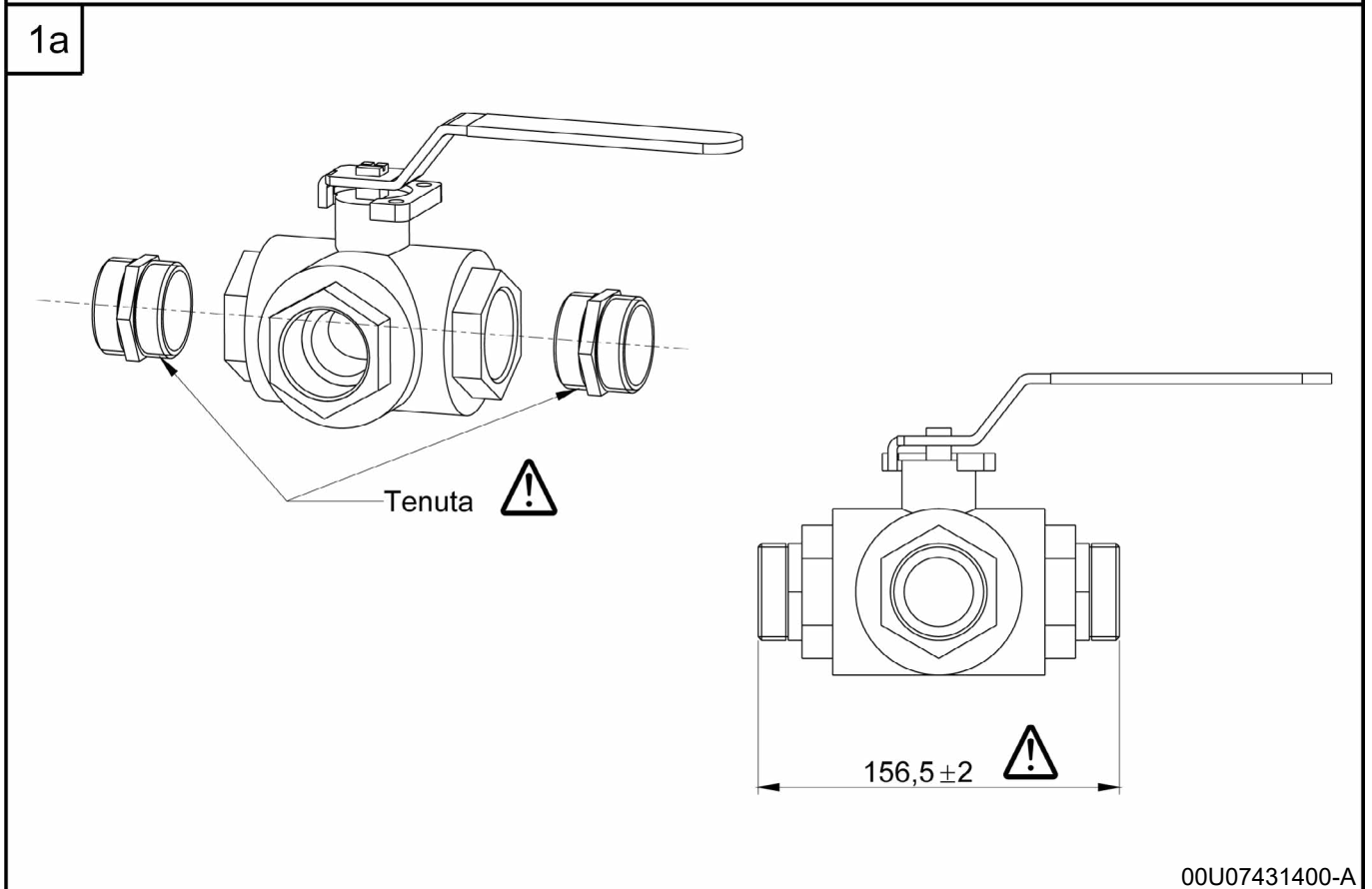
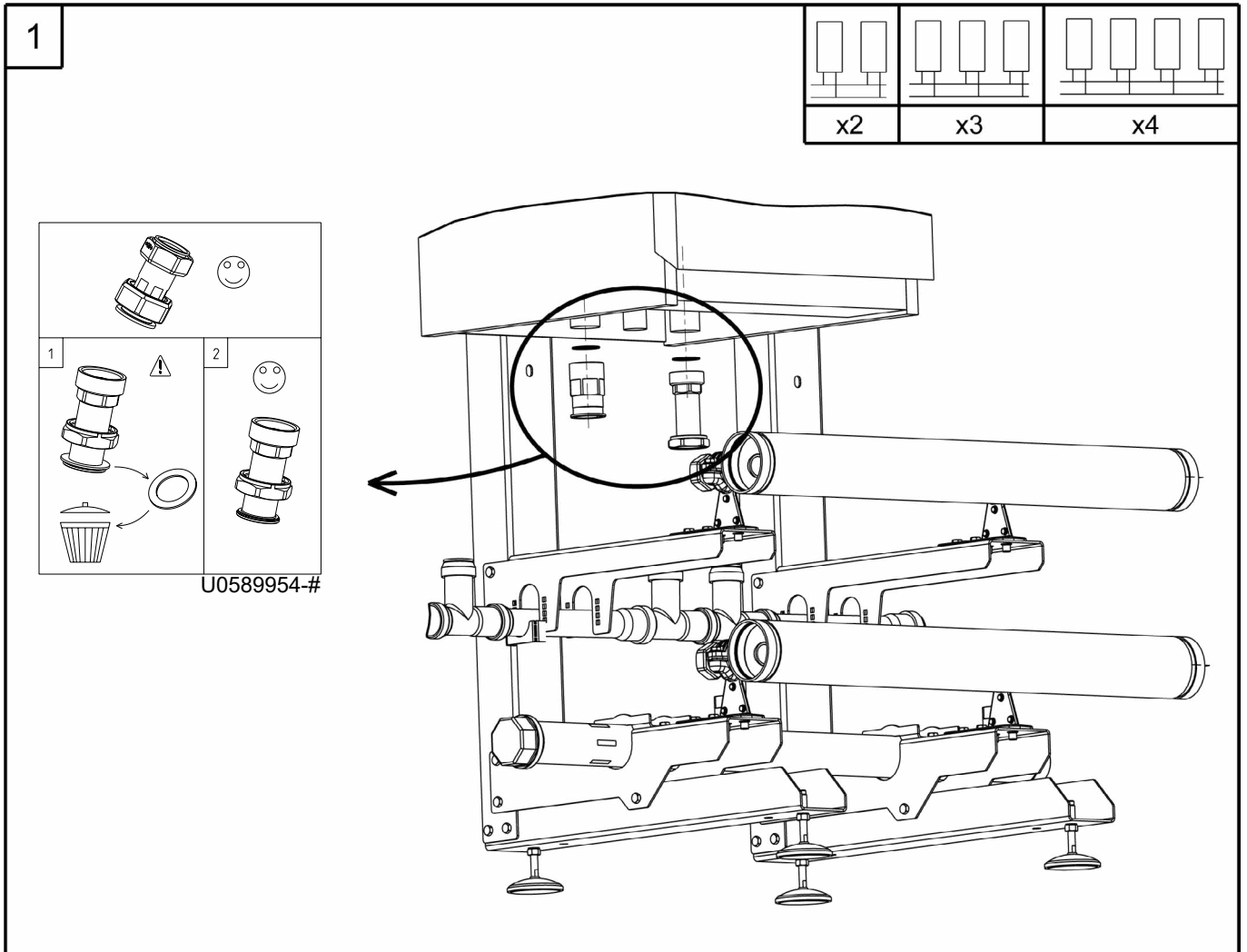

Fare riferimento alle istruzioni della caldaia per il collegamento del circolatore.

9.2. Assemblaggio



00U07431400-A

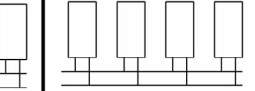

2

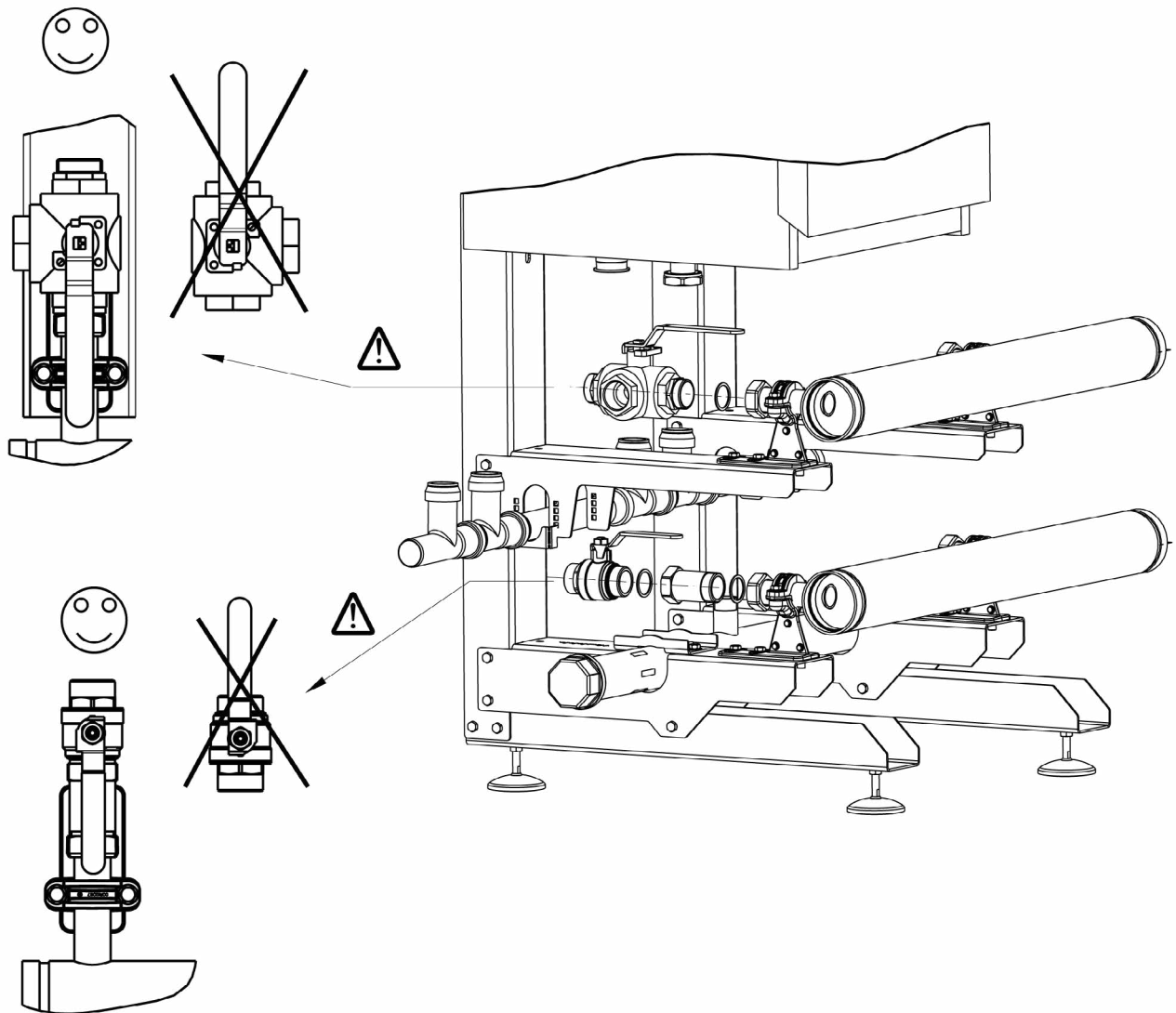
		
x2	x3	x4



00U07431500-A

3

		
x2	x3	x4

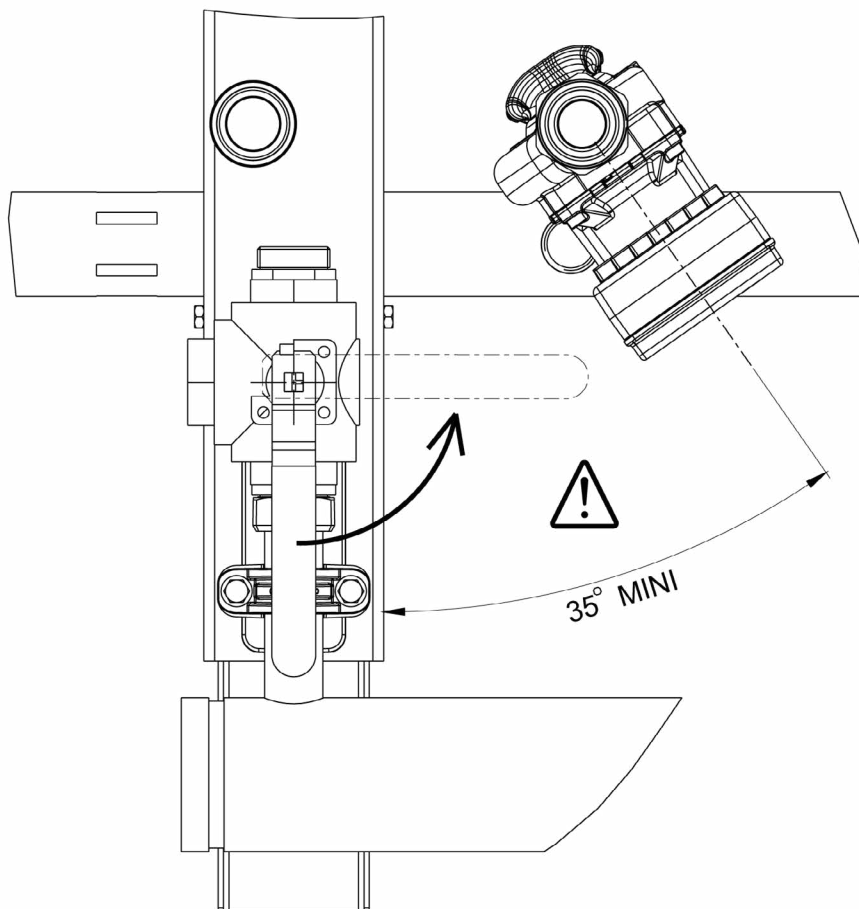
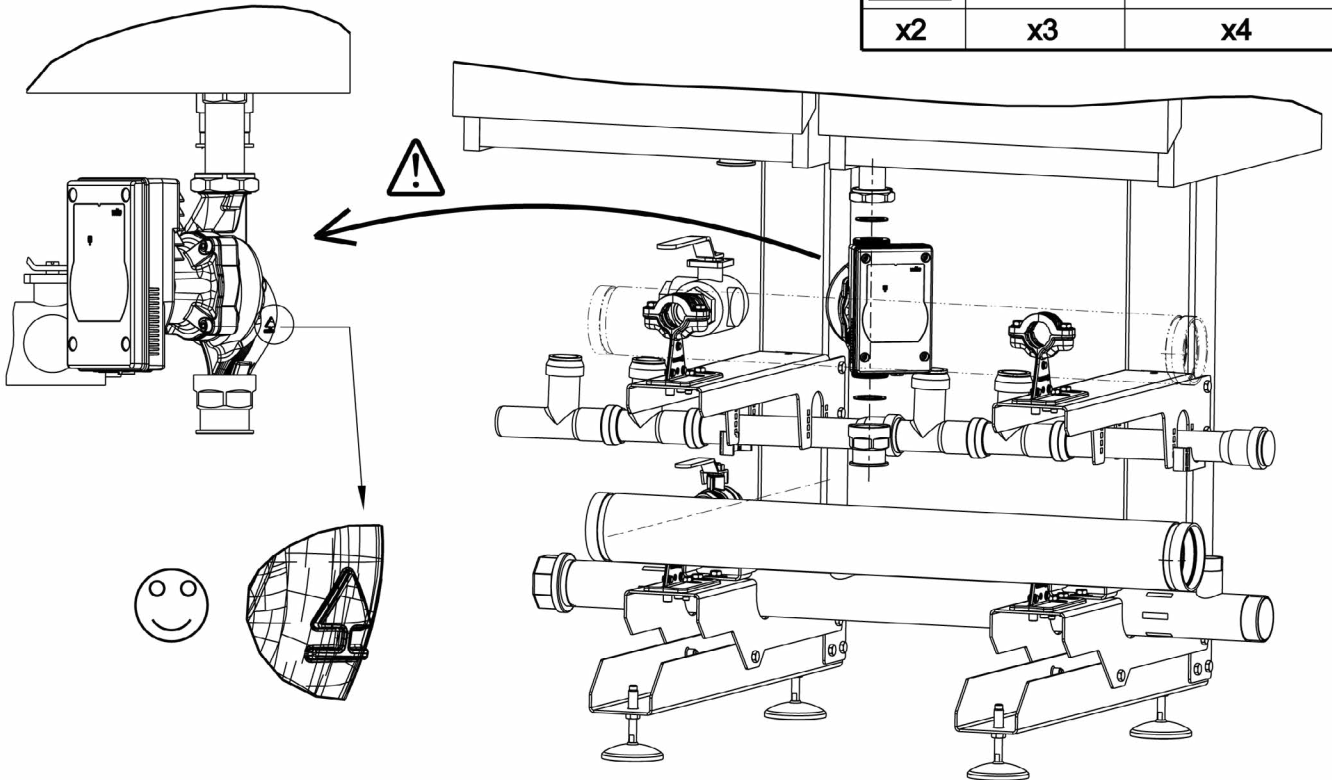

00U07431590-A

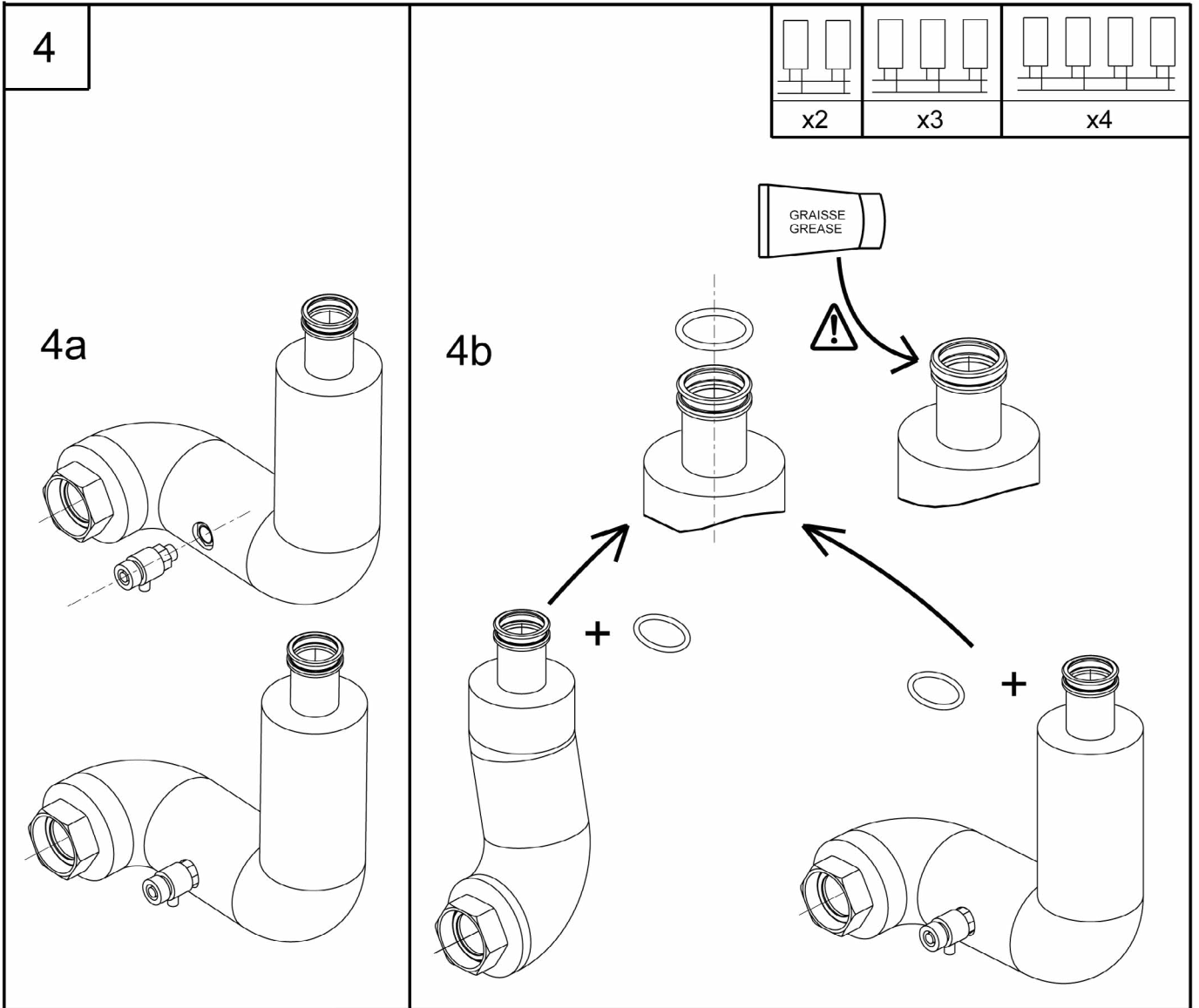

00U07413950-A

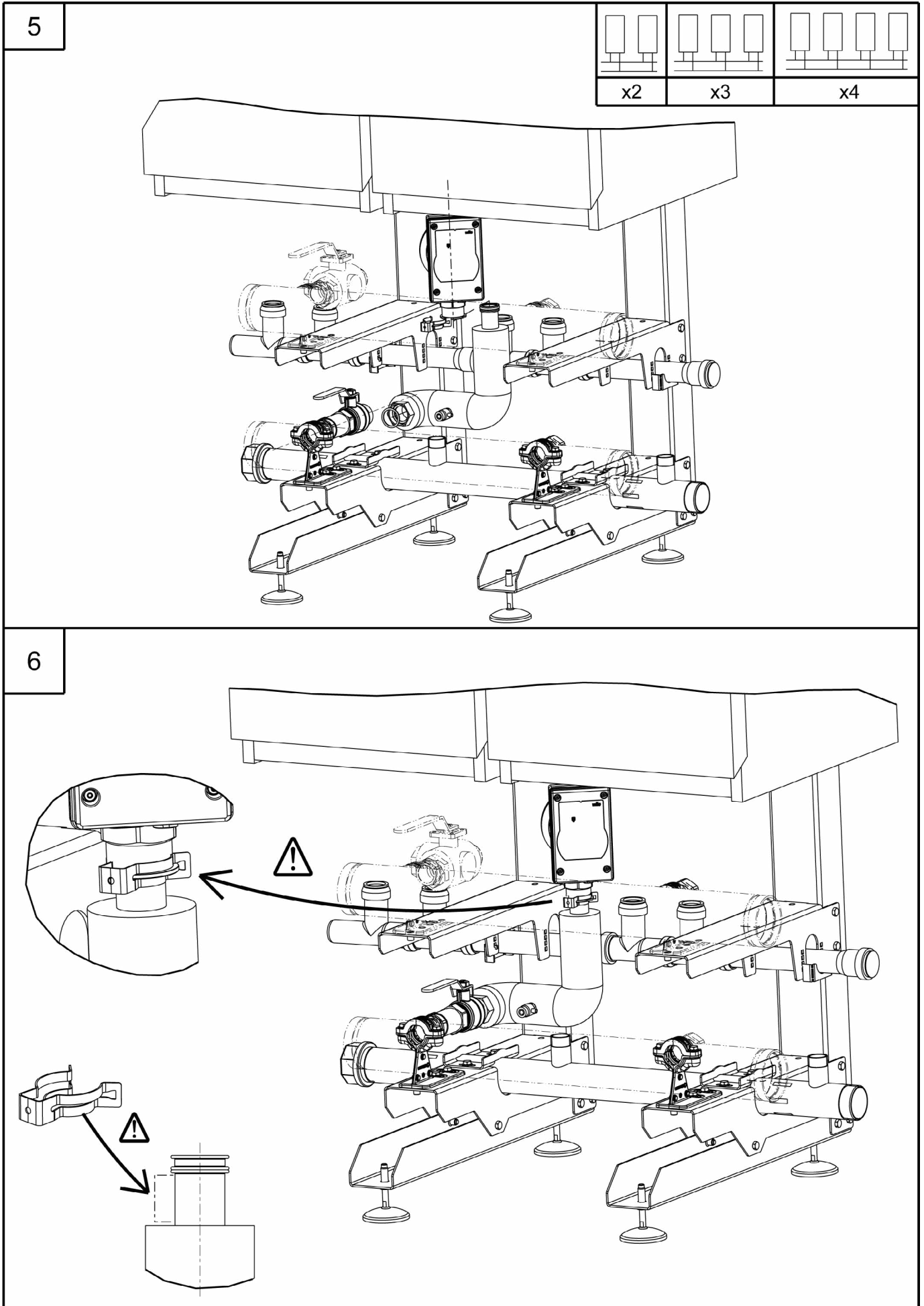

00U07431680-A

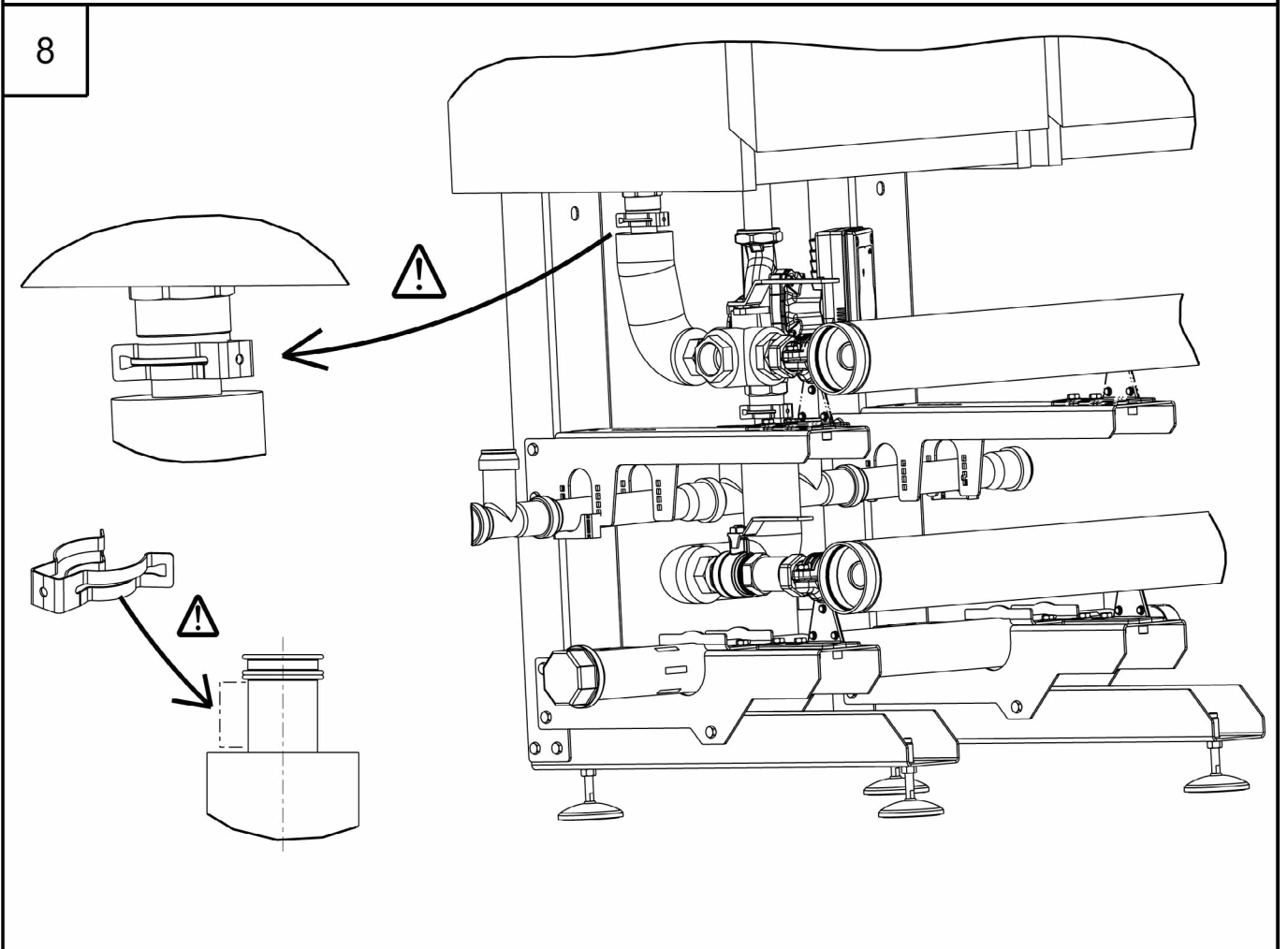
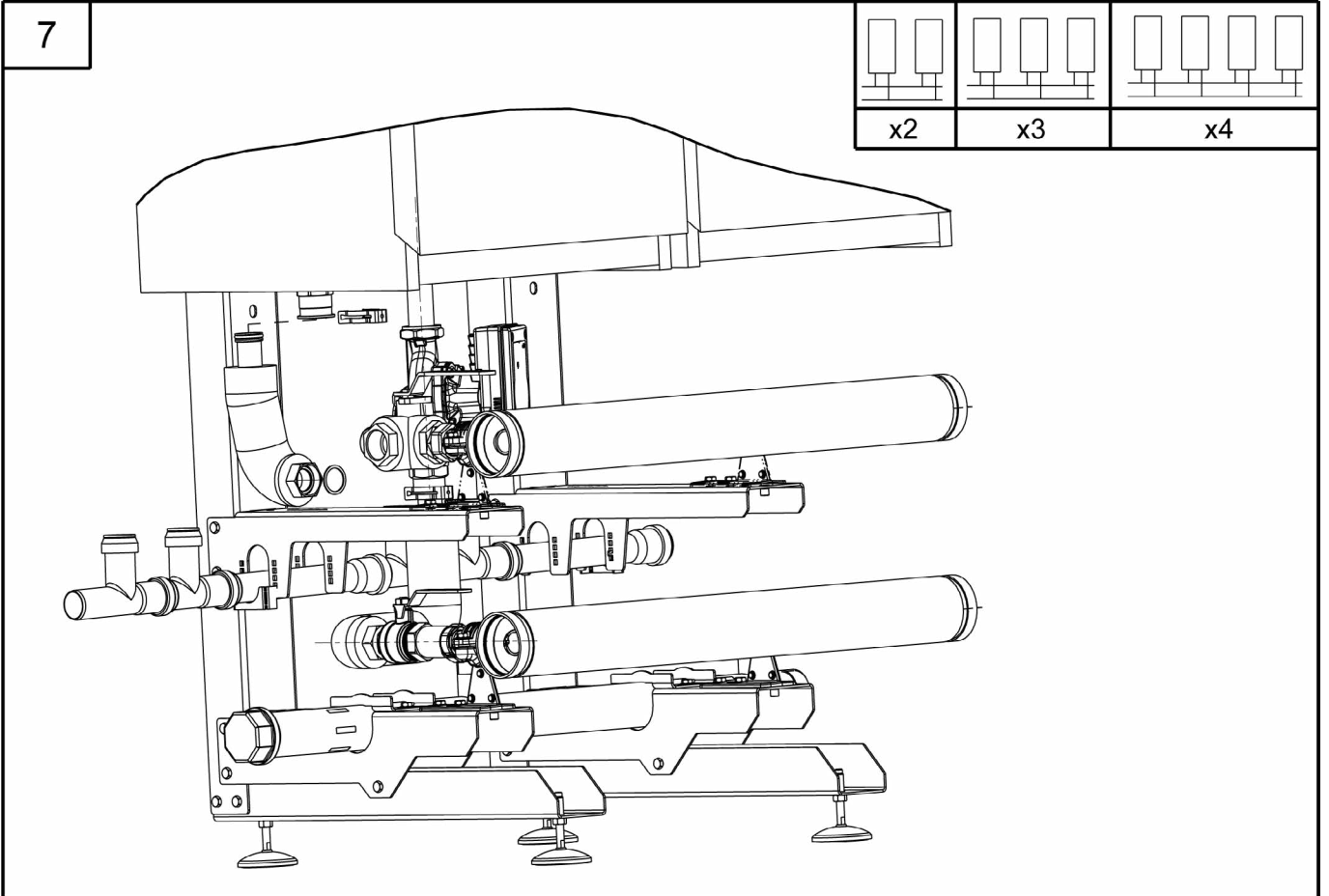

00U0743186 0-A

10. COLLEGAMENTO CONDENSA, VALVOLA E GAS

10.1. Elenco dei componenti

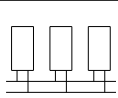
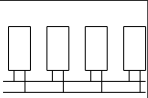
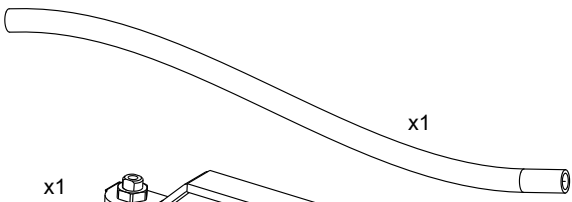
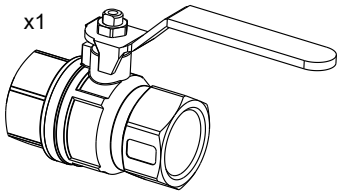
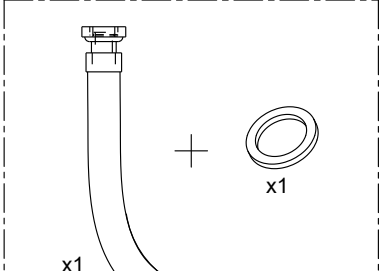
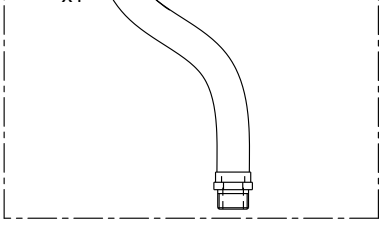
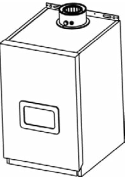
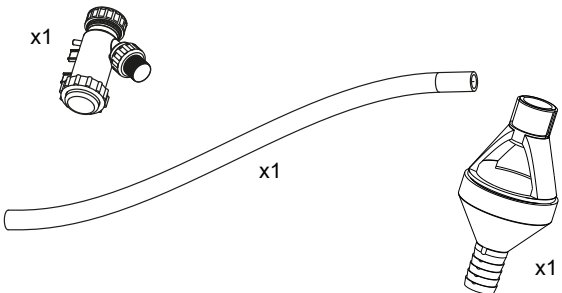
					
082667	 x1	x2	x3	x4	35
082668	 x1	x2	x3	x4	60 80 100
082669	 x1	x2	x3	x4	115
082670	 x1	x2	x3	x4	150
	 x1	x2	x3	x4	

10.2. Assemblaggio

1

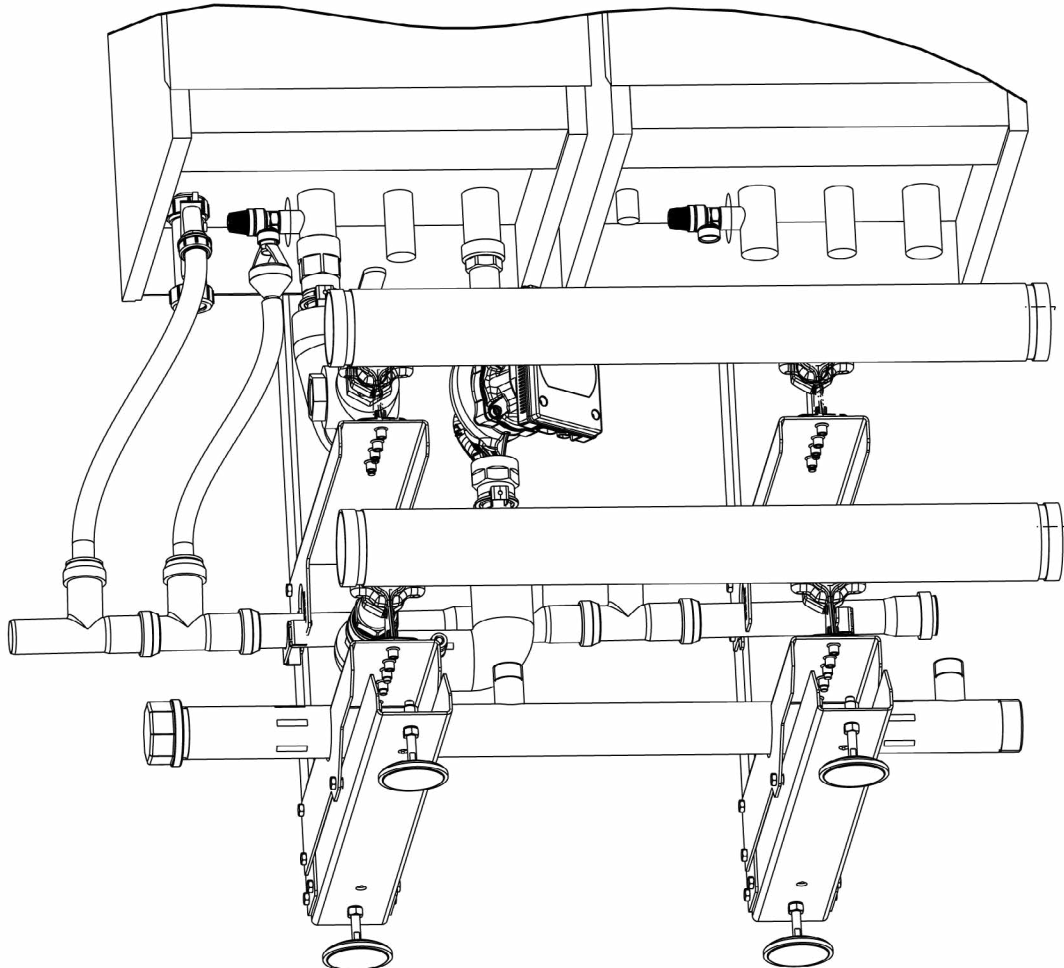
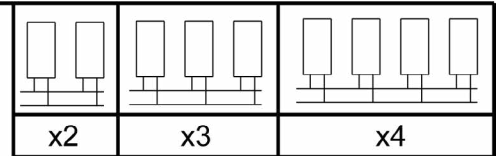
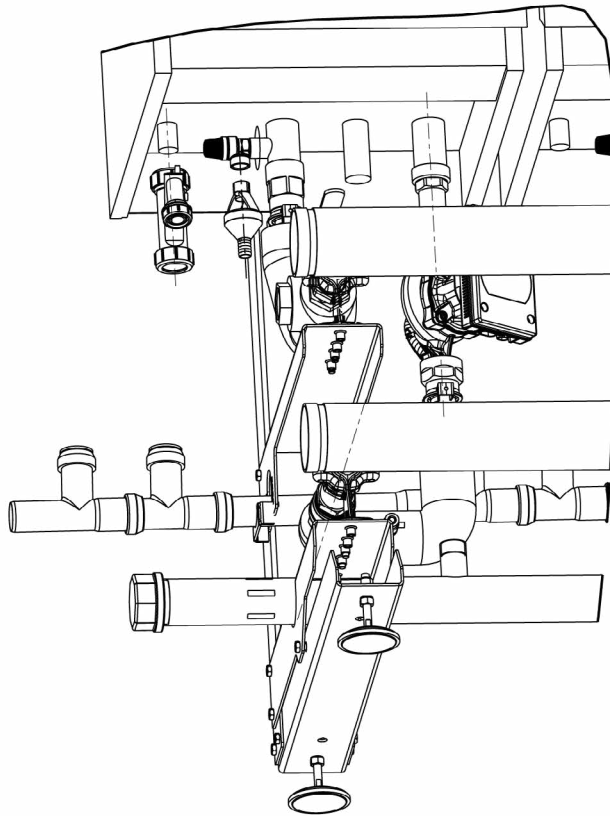

00U07432410-A

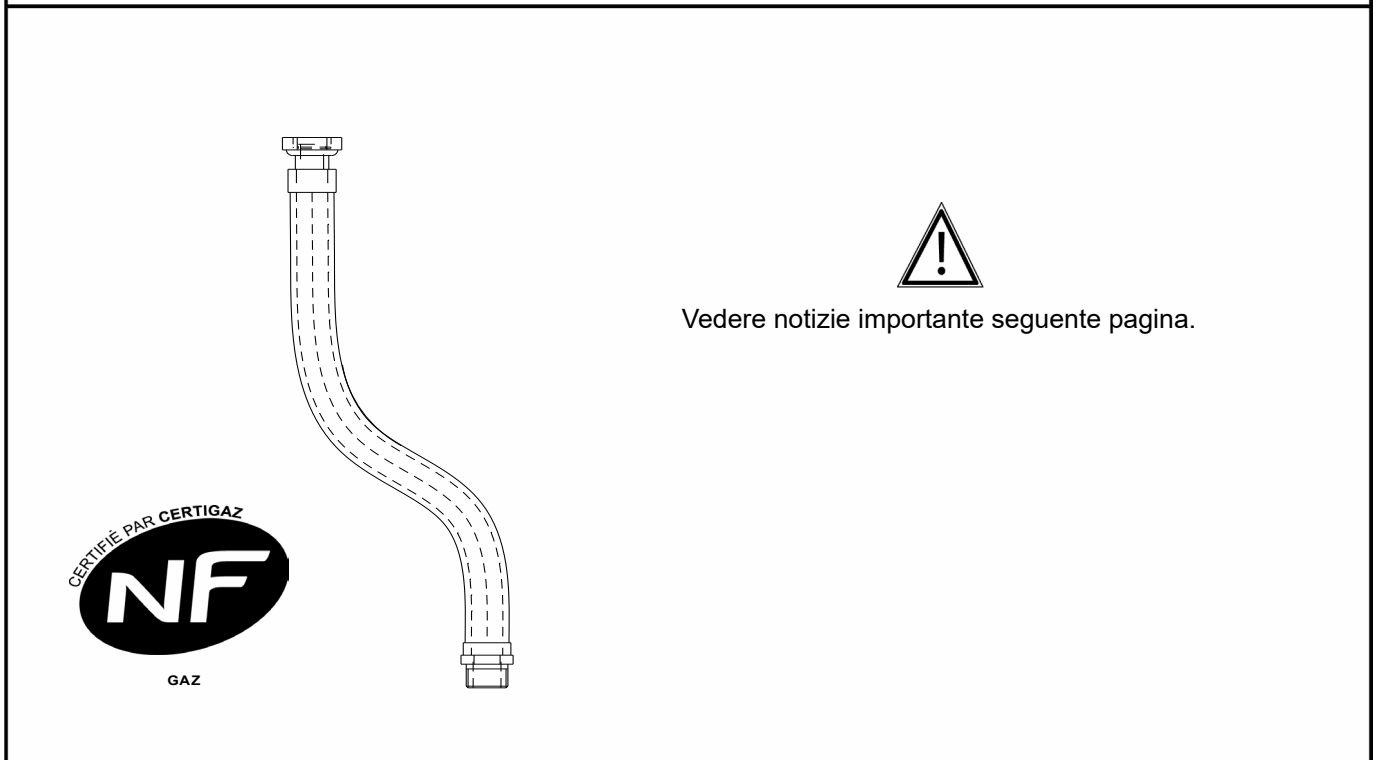
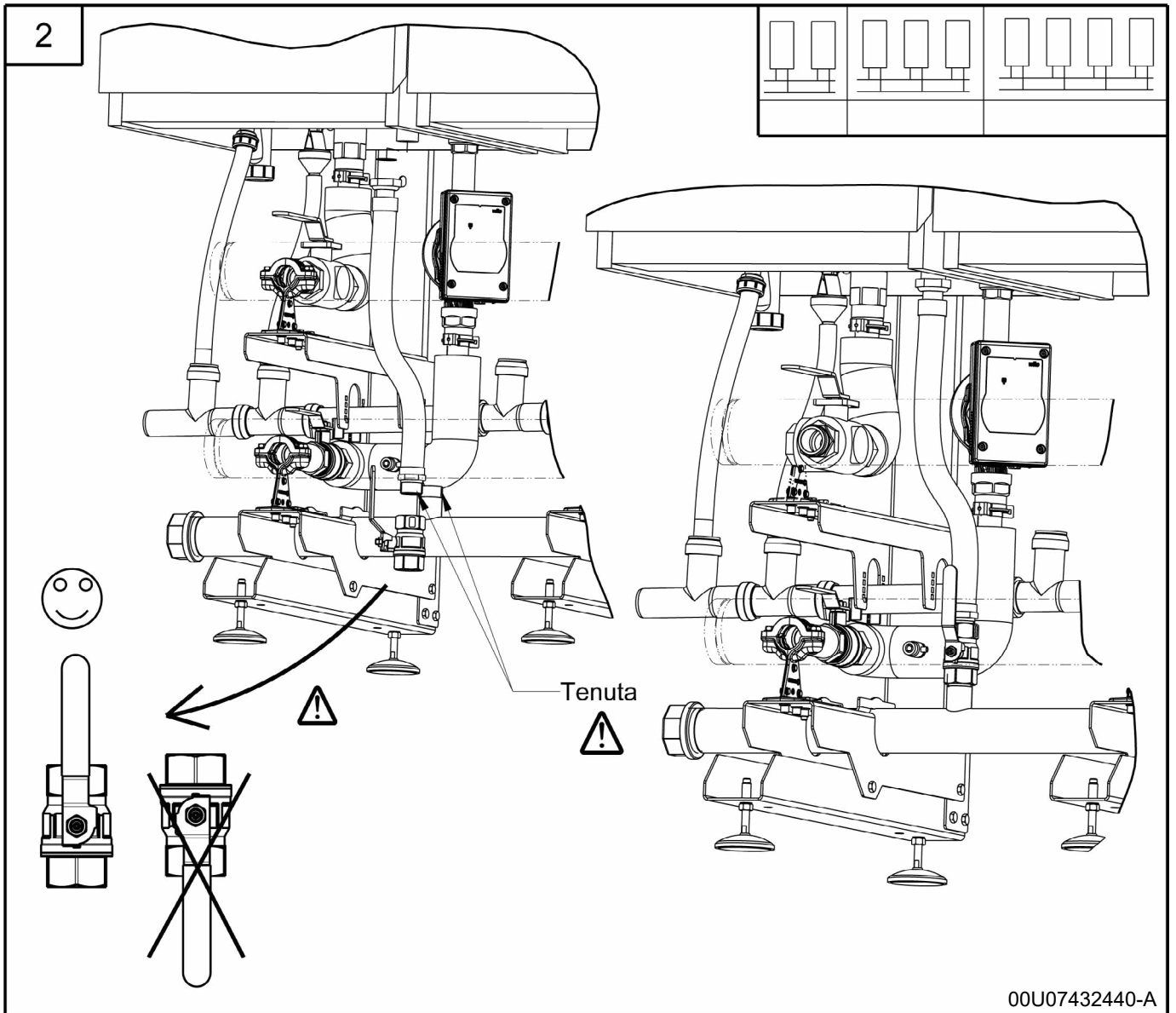

Il flessibile U0628714 NF è un flessibile per gas conforme alla norma NF D 36-123. La pressione massima di utilizzo (P_{MAX}) è di 2 bar.

Il reparto di curvatura massimale di montaggio ammissibile è di 90 mm maxi.



Qualsiasi danneggiamento o deterioramento di tutto o parte del tubo flessibile richiede la sua sostituzione. Inoltre, è vietata qualsiasi modifica del tubo flessibile;

Le torsioni, le curvature e le vibrazioni troppo importanti devono essere evitate;

Gli impianti devono essere realizzati rispettando la regolamentazione in vigore e le regole dell'arte.

È obbligatorio seguire le indicazioni di montaggio dei fabbricanti del tubo flessibile e dell'apparecchio, in particolare per quanto riguarda la posizione e l'orientamento dei punti di collegamento;

Questo tubo flessibile metallico corrugato non deve distribuire GPL in fase liquida;

La perdita di carico per assicurare la portata di gas dipende dal tipo di gas, dal diametro, dalla lunghezza e dalle condizioni di installazione del tubo flessibile.

Controllare:

la compatibilità delle estremità del tubo flessibile con i raccordi dell'apparecchio e dell'erogazione del gas.

Possono eventualmente essere necessari degli adattatori;

l'adeguatezza della portata del tubo flessibile alla portata richiesta dall'apparecchio.

Il tubo flessibile è fornito con un giunto piano gas D30x22,4x2 NF D 36-123 ;

In funzione dello stato del giunto, può essere necessario sostituirlo dopo lo smontaggio;

Si raccomanda di realizzare la tenuta dei montaggi mediante l'interposizione di una guarnizione realizzata con un materiale che deve tassativamente essere compatibile con il gas conformemente alla norma NF EN 751;



IMPORTANTE: verificare la compatibilità dei raccordi dell'apparecchio e dell'erogazione del gas.

Questo flessibile è destinato unicamente all'allacciamento del gas dei pacchetti cascata VARFREE e montato con i componenti forniti.

Il flessibile non ha una data limite di utilizzo, tuttavia in caso di deterioramento dovrà essere sostituito.

11. COLLEGAMENTO KIT SICUREZZE INAIL

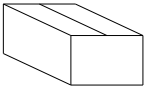
11.1. Elenco dei componenti

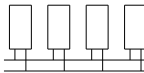
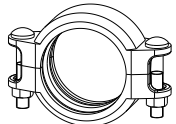
				
082681	 x2	x1		
082682			x1	
082683				x1

11.2. Assemblaggio

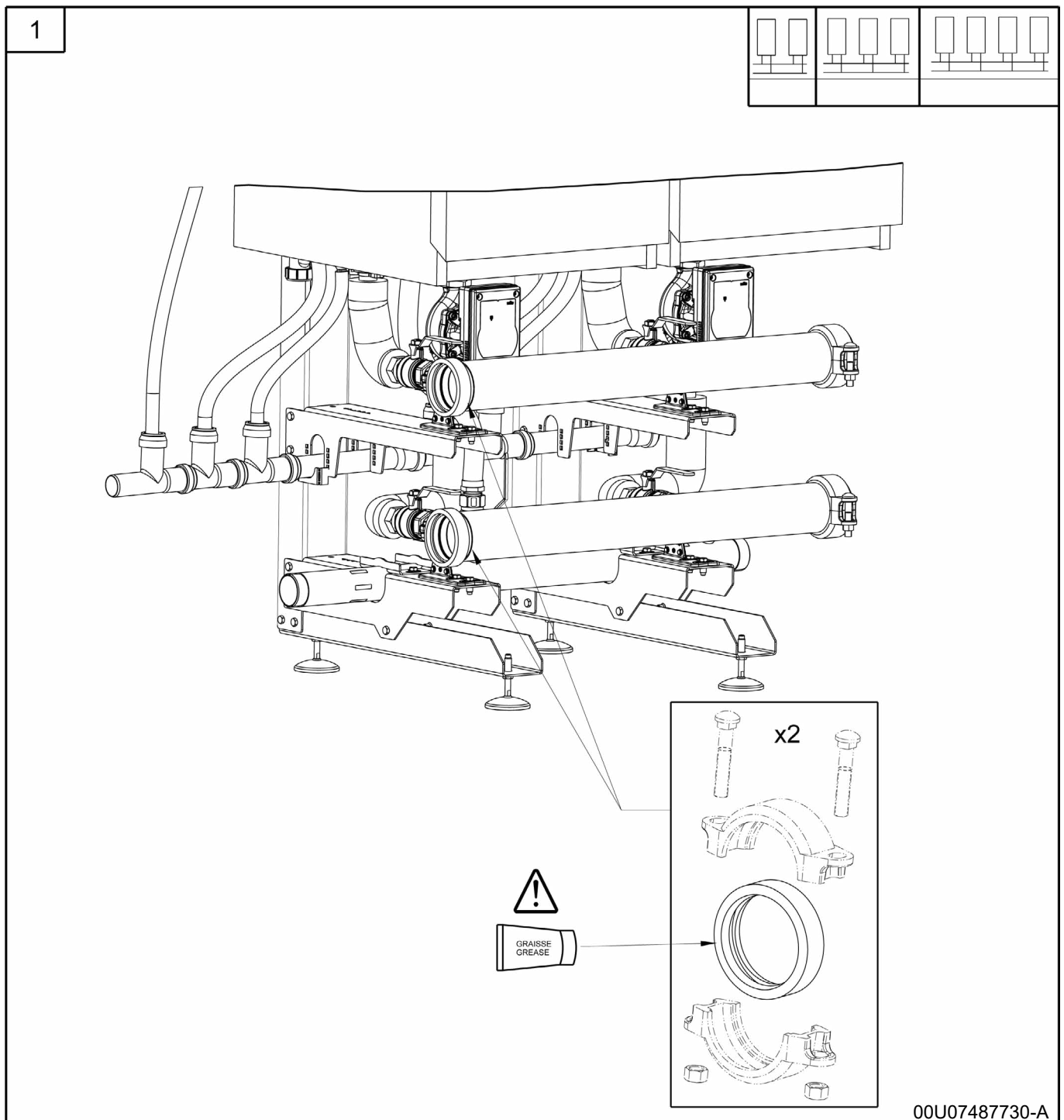

2

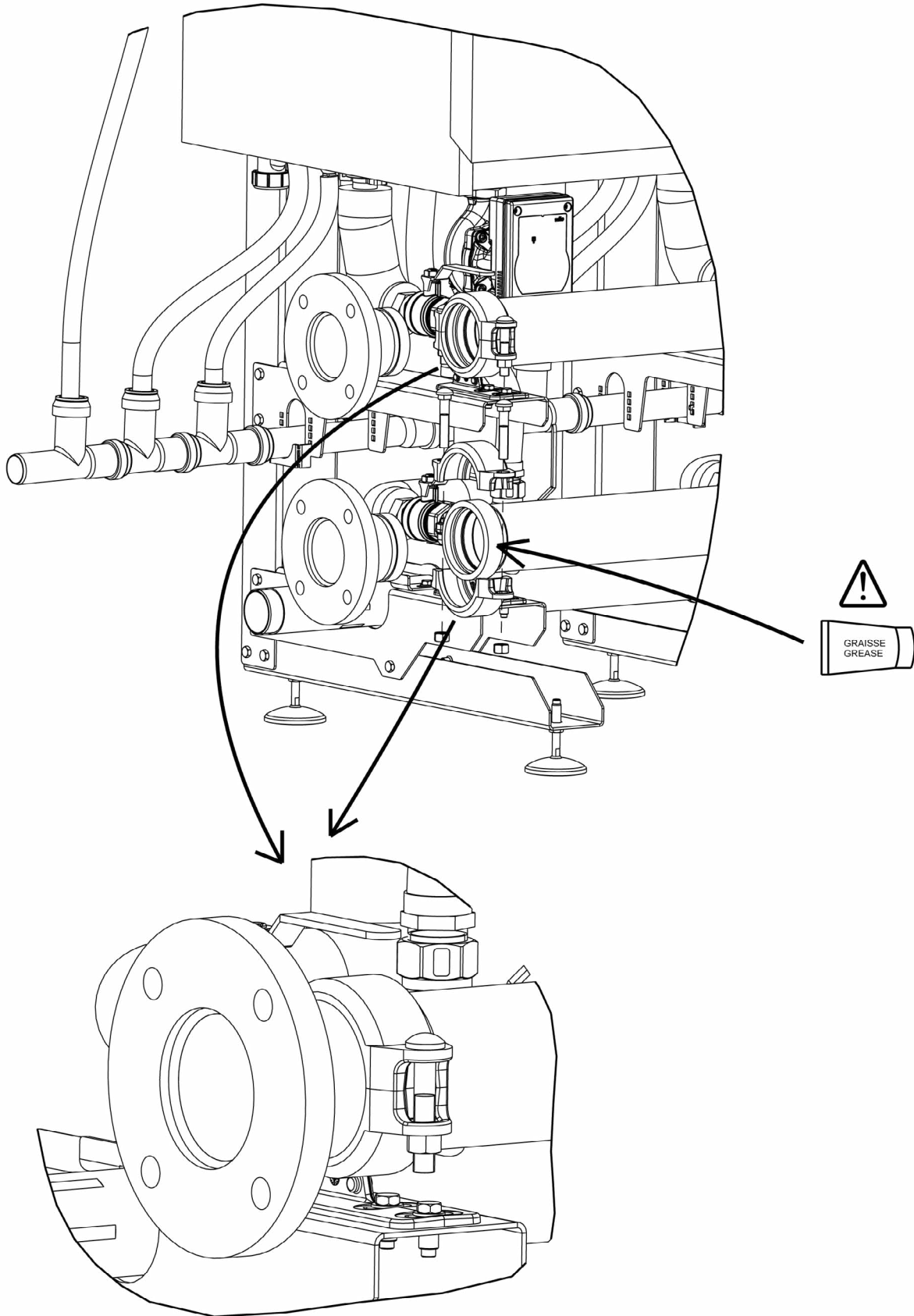
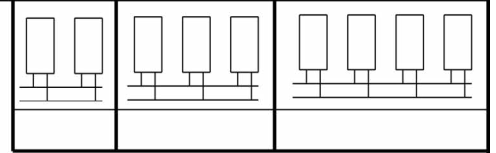

00U07487730-A-F1

3

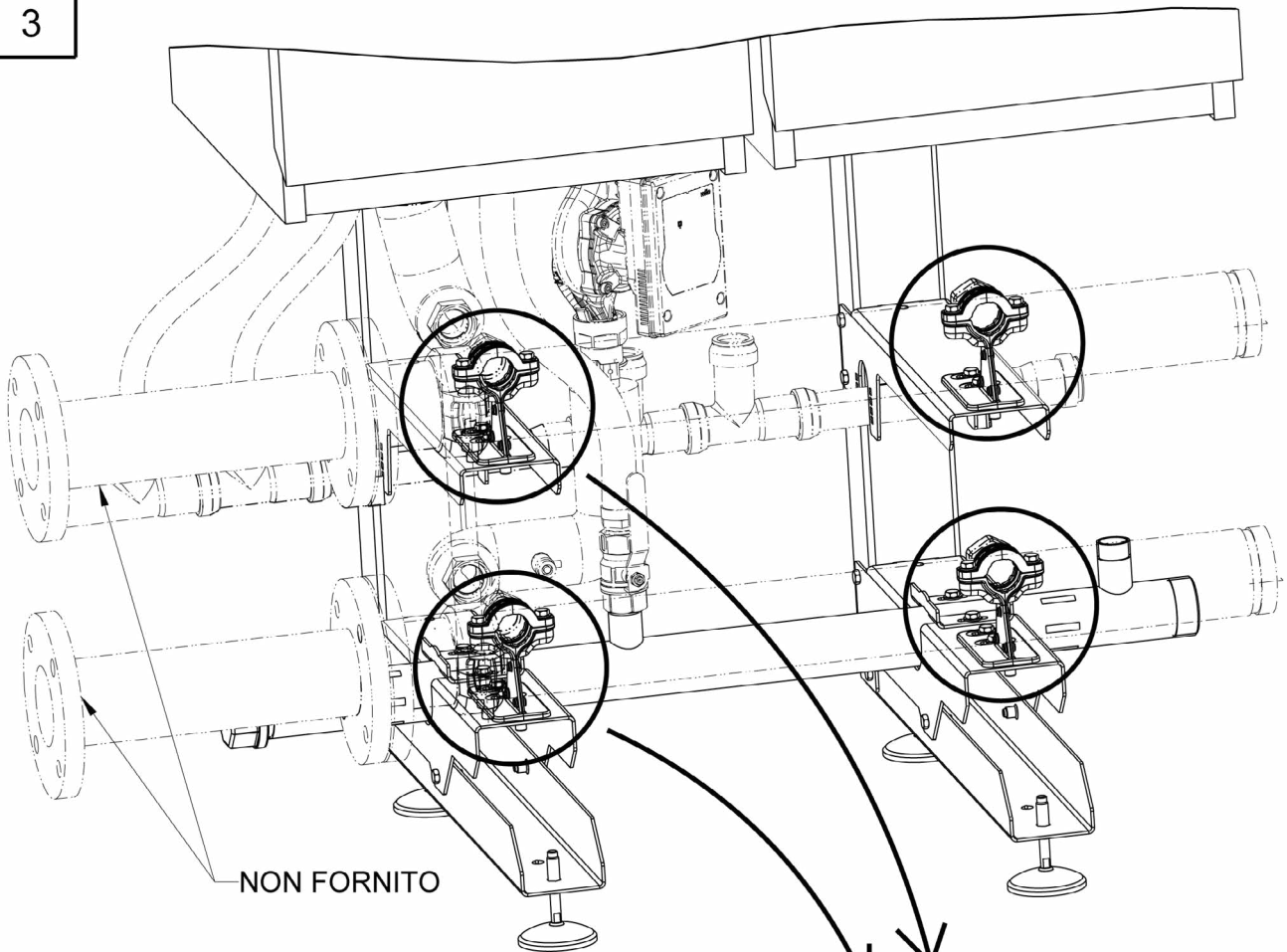

NON FORNITO



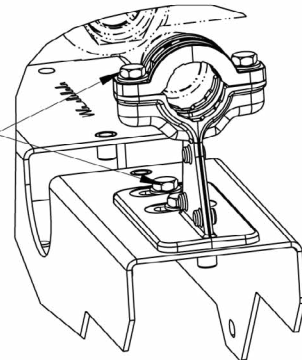

Stringere le viti HM8 - 8Nm maxi



00U07432570-A

12. COLLEGAMENTO FILTRO E REGOLATORE GAS

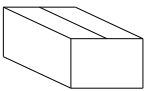
12.1. Elenco dei componenti

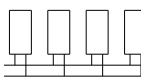
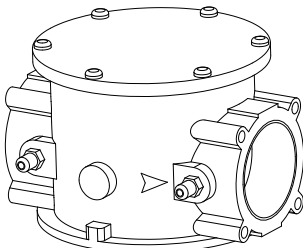



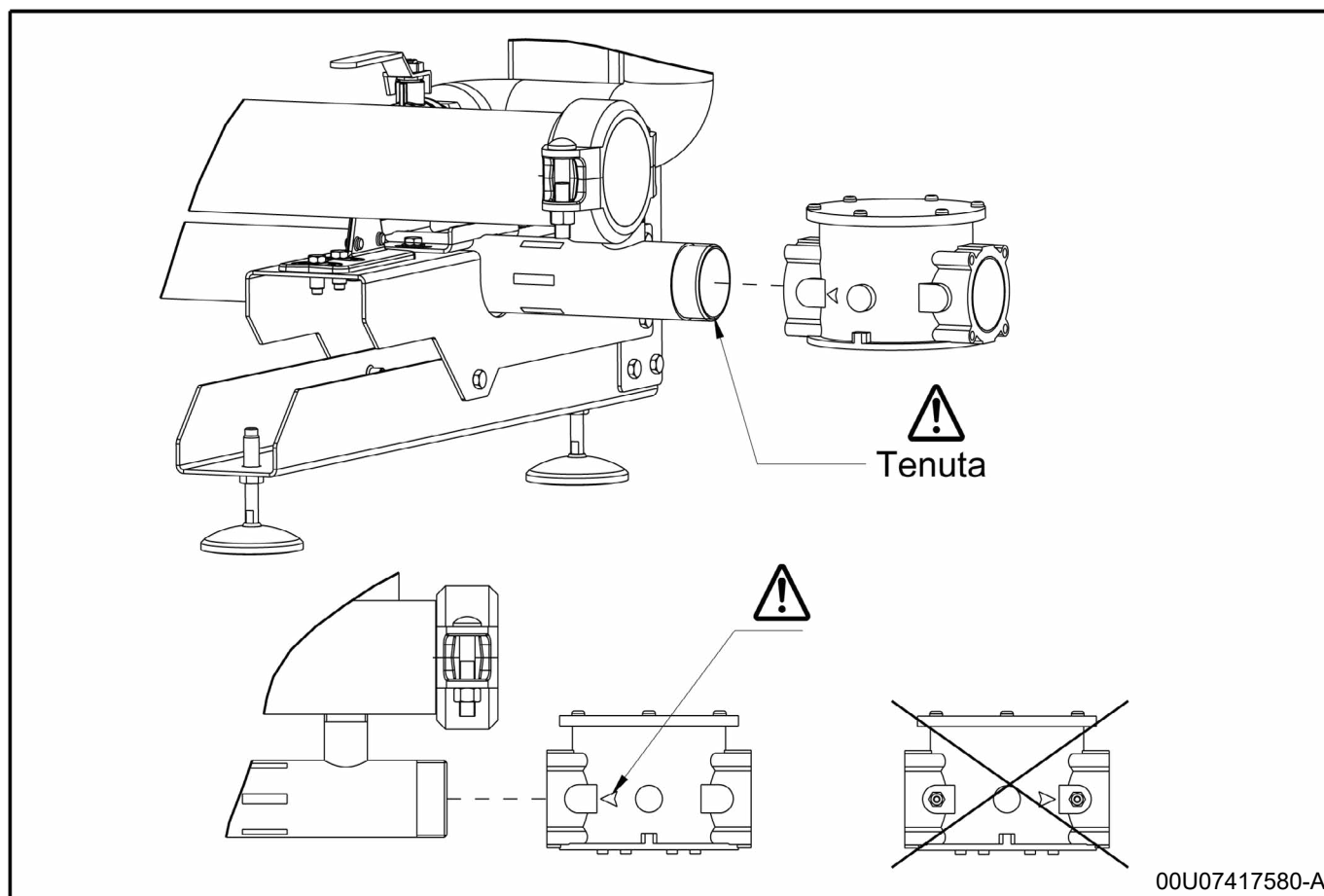





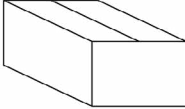

				
082321	20 mbar x1 	x1	x1	x1









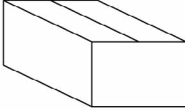

12.2. Assemblaggio

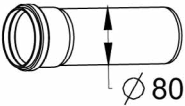

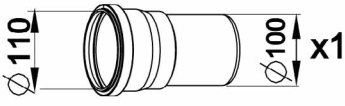
13. COLLEGAMENTO DEI FUMI

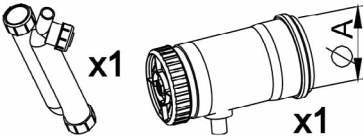
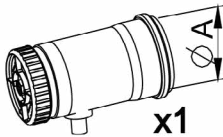
13.1. Elenco dei componenti

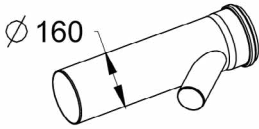
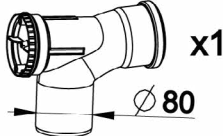
								
35 - 60			80 -100			115		
								
083813	083816	083819	083814	083818	083821	083815	083818	083822
2 x 040945 2 x 083848 1 x 700391	3 x 040945 3 x 083848 1 x 700391	4 x 040945 4 x 083848 1 x 700391	2 x 041052 2 x 083850 1 x 700391	3 x 041052 3 x 083849 1 x 041054	4 x 041052 4 x 083849 1 x 041054	2 x 041052 2 x 083849 1 x 041054	3 x 041052 3 x 083849 1 x 041054	4 x 041052 4 x 083851 1 x 082336
						150		
								
						083815	083847	083822
						2 x 041052 2 x 083849 1 x 041054	3 x 041052 3 x 083851 1 x 082336	4 x 041052 4 x 083851 1 x 082336

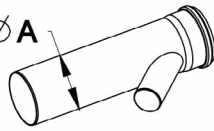
			
040945	 x1	 x1	 x1
			 x1
041052	 x1	 x1	 x1
041054 082336 700391	 x1	 x1	 x1
			041054 : $\phi A = 200$ 082336 : $\phi A = 250$ 700391 : $\phi A = 160$
083848	 x1	 x1	
083849 083850 083851	 x1	 x1	083849 : $\phi A = 200$ 083850 : $\phi A = 160$ 083851 : $\phi A = 250$

00U07417630-A-F1

13.2. Assemblaggio

Se il camino si trova a sinistra della cascata, l'orientamento del condotto deve essere invertito in confronto alle immagini di fianco.

13.2.1. Per caldaie 35 e 60

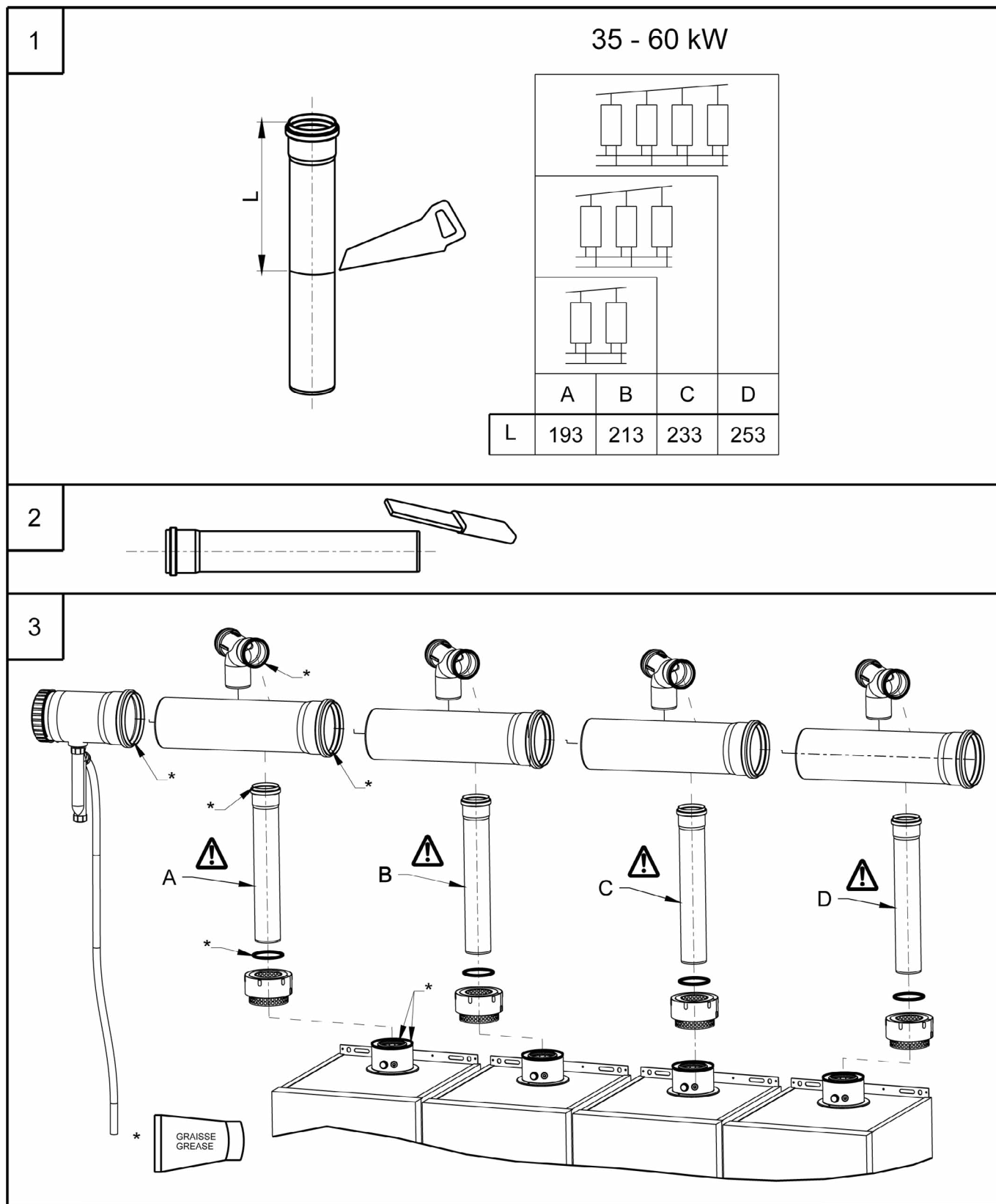

00U07419780-A

13.2.2. Per caldaie 80, 100, 115 e 150

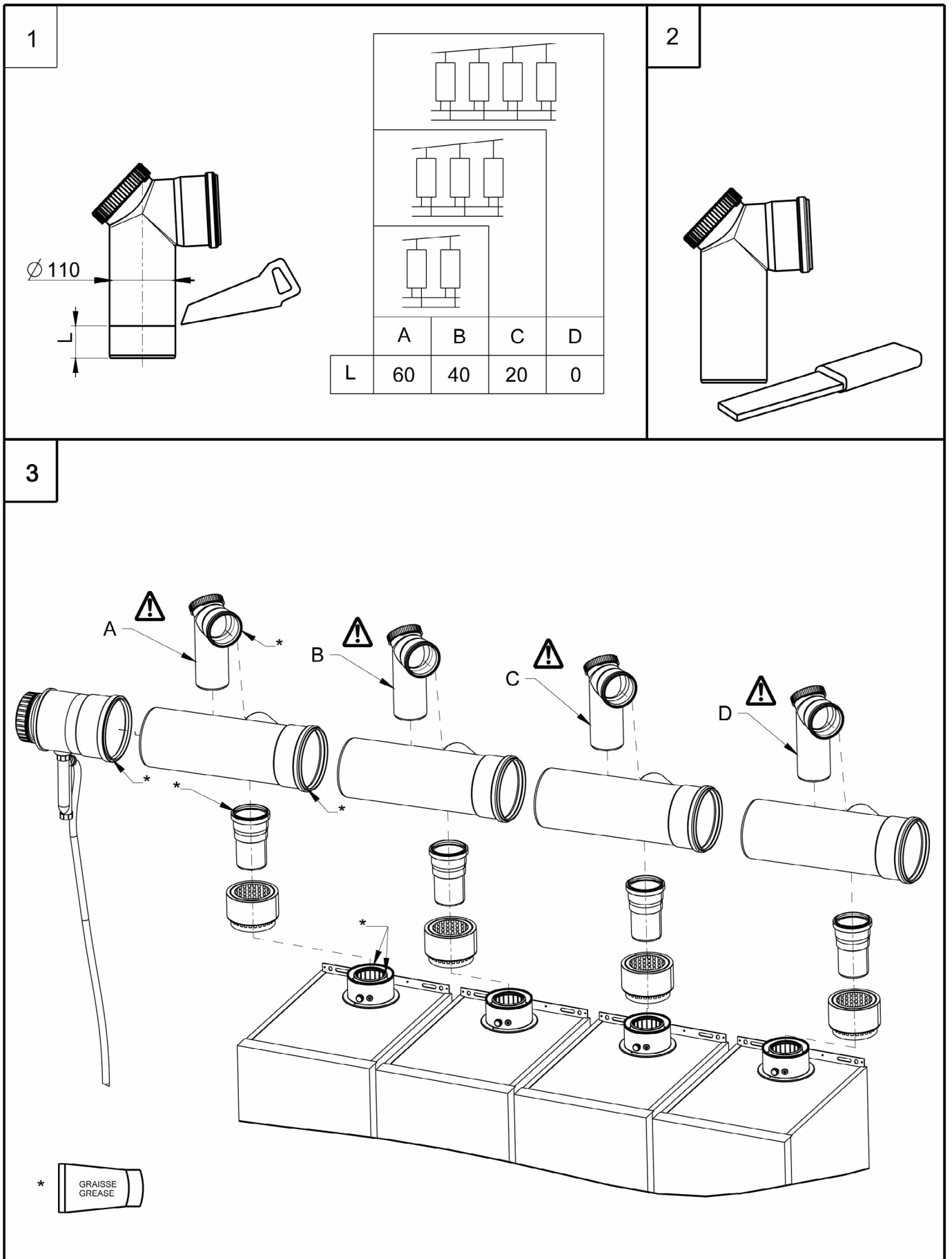

00U07420120-A

13.2.3. Per caldaie di qualsiasi potenza

4

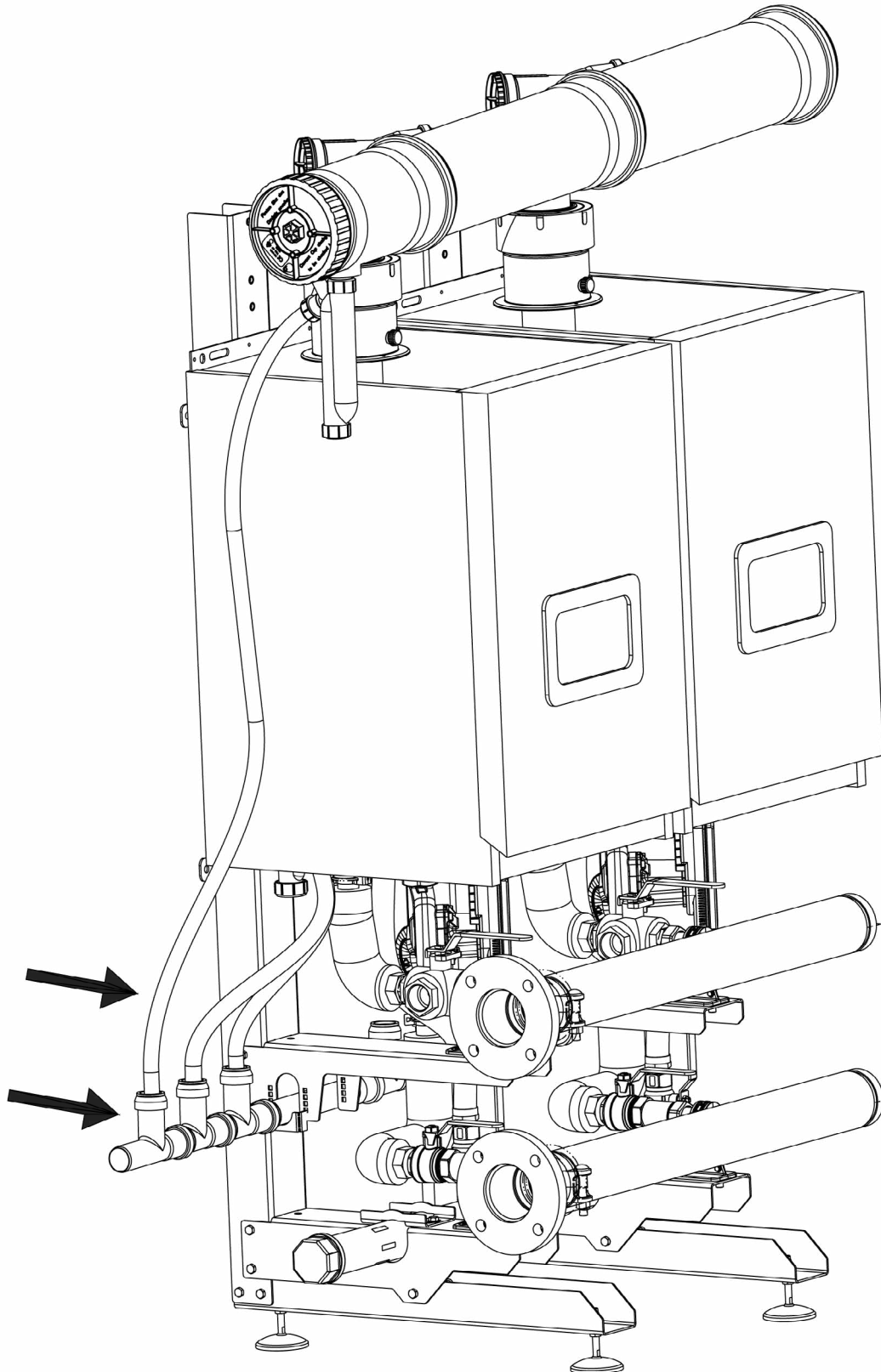
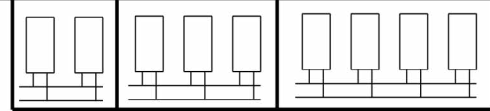

00U07432730-A

**SATC ATLANTIC SOLUTIONS CHAUFFERIE**

1 route de Fleurville
 01190 PONT DE VAUX
 Tél. : 03 51 42 70 03
 Fax : 03 85 51 59 30
www.atlantic-solutions-chaufferie.fr

**THERMOR SERVICES**

17 rue Croix Fauchet - BP 46
 45141 SAINT-JEAN-DE-LA-RUELLE
 Tel.:  **N°Azur 0 810 081 045**
0,06 € TTC/MN
www.thermor.fr

**ATLANTIC BELGIUM SA**

Oude Vijverweg 6,
 1653 Dworp
 Tel. : 02/357 28 28
 Fax : 02/351 49 72
www.ygnis.be

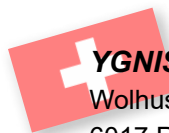
**YGNIS AG**

Wolhuserstrasse 31/33
 6017 RUSWIL CH
 Tel.: +41 (0) 41 496 91 20
 Fax : +41 (0) 41 496 91 21
 Hotline : 0848 865 865
www.ygnis.ch

**YGNIS ITALIA SPA**

Via Lombardia, 56
 21040 CASTRONNO (VA)
 Tel.: 0332 895240 r.a.
 Fax : 0332 893063
www.ygnis.it

**HAMWORTHY HEATING LIMITED**

Customer Service Center
 Wessex House,
 New Fields Business Park,
 Stinsford Road, Poole,
 Dorset BH17 0NF
 Tel 01202 662500
 Fax 01202 662522
service@hamworthy-heating.com
www.hamworthy-heating.com

**GROUPE ATLANTIC ESPAÑA, S.C.T., S.A.**

Calle Antonio Machado 65,
 Edificio Sócrates
 08840 Viladecans (Barcelona)
 Tel.: +34 988 144 522
callcenterygnis@groupe-atlantic.com
www.ygnis.es

Others countries, contact your local retailer



**GROUPE
 ATLANTIC**
SITE DE PONT-DE-VAUX

1 route de Fleurville
 FR - 01190 PONT-DE-VAUX