

Accessio

USER-FRIENDLY THERMOFLUID RADIATOR FOR PERCEPTION OF COMFORT SIMILAR TO CENTRAL HEATING

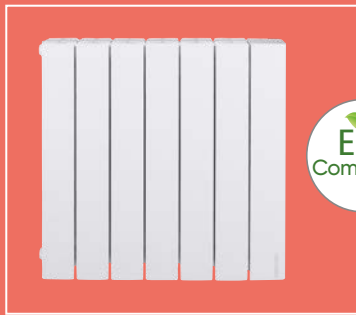

ErP
Compliant



+ PRODUCT

COMFORT

- Thermofluid technology providing long-lasting and soft heat
- Homogeneous and gentle heat spread

SAVINGS

- Up to 25% energy savings* through finest digital controls and programming
- 6-command pilot wire: Comfort, Comfort -1°C, Comfort -2°C, Eco, Anti-frost, Off
- High-quality electronic thermostat
- ErP-compliant

USER-FRIENDLINESS

- Ergonomic LCD digital controls showing temperature and energy consumption
- 2 modes: Manual/Prog
- ASP (Anti-Staining Process) to reduce staining on wall and on equipment
- Easy to install: H-shaped vertical support

DESIGN

- Colour: White (RAL 9016)
- Elegant classic design

GENTLE HEAT RADIATOR

300 TO 2000 W

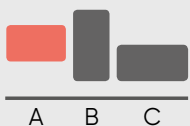

Model available**



LCD digital controls



Energy savings



Heating element type

Accessio



- 1 Heat-conducting fluid
- 2 LCD digital controls

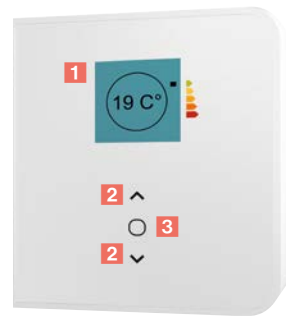

- 1 Digital screen showing temperature and energy consumption
- 2 Navigation buttons
- 3 Access to menu/validation

INSTALLATION DIMENSIONS

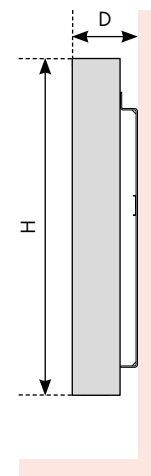
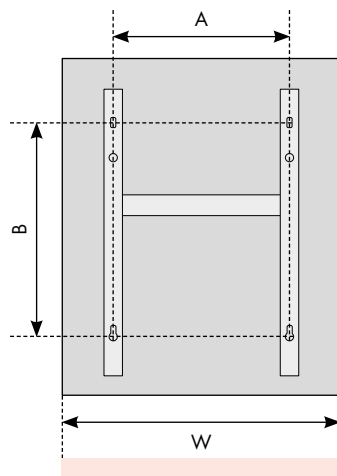

TECHNICAL DATA

OUTPUT (W)	DIMENSIONS (mm)					NET WEIGHT (kg)
	WIDTH (W)	HEIGHT (H)	DEPTH (D)	A	B	
300	410	575	127	161	354	8.25
500	410	575	127	161	354	8.25
750	490	575	127	242	354	9.9
1000	490	575	127	242	354	9.9
1250	651	575	127	400	354	13.2
1500	732	575	127	400	354	14.8
2000	973	575	127	725	354	19.7