

HAMWORTHY
heating products

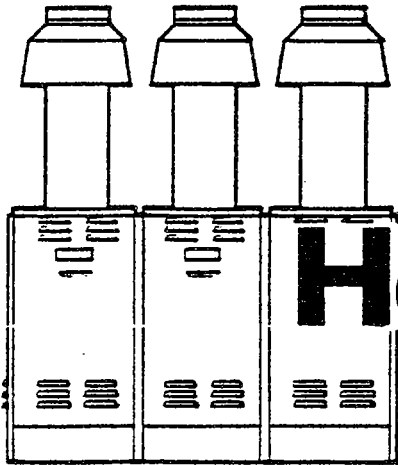

Hamworthy Heating Products

Wessex 50Mk IVD

Hot Water Boiler
Installation, Commissioning
& Maintenance Manual

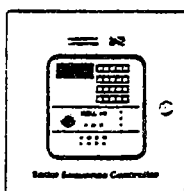
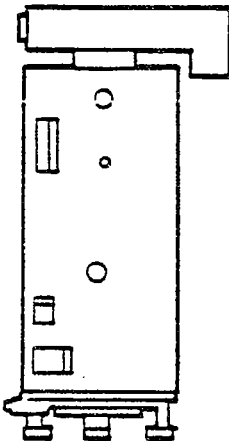
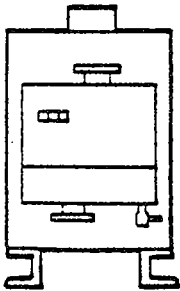

BS 5750 Part 1
Certificate No. FM 10082



HAMWORTHY
heating products

INSTALLATION, COMMISSIONING AND MAINTENANCE MANUAL

WESSEX MK IV D

1 X 50

2 X 50

3 X 50

COMPACT 100

**HOT WATER BOILERS FOR HEATING AND DOMESTIC HOT WATER
FOR USE WITH NATURAL GAS ONLY**

**NOTE: THE INSTRUCTIONS SHOULD BE READ AND UNDERSTOOD BEFORE ATTEMPTING
TO INSTALL, COMMISSION OR OPERATE THIS UNIT!**

**THE WESSEX BOILER IS INTENDED FOR USE AS A COMMERCIAL APPLIANCE AND IS NOT
CERTIFIED FOR USE IN DOMESTIC APPLICATIONS.**

**THIS BOILER IS FOR USE ON NATURAL GAS (2ND FAMILY) ONLY. PLEASE
ENSURE RELEVANT INFORMATION REQUIRED WITHIN THE DOCUMENT IS FOUND
RELATING TO SPECIFIC GAS TO BE FIRED BEFORE FIRING THE BOILER.**

**THIS BOILER HAS BEEN TESTED TO COMPLY WITH THE GAS
APPLIANCE DIRECTIVE (90/396/EEC).**

EC TYPE CERTIFICATE NO. ***
EC IDENTIFICATION NO. *******

THIS BOILER COMPLIES WITH THE MACHINERY DIRECTIVE

**PUBLICITY NO. WAS HPM 2018 1288
RENUMBERED 500001007 "C"**



HAMWORTHY
heating products

CONTENTS

	PAGE
1.0 INTRODUCTION	1
2.0 TECHNICAL DATA	2
3.0 GENERAL REQUIREMENTS	2
4.0 LOCATION	3
5.0 GAS SUPPLY	3
6.0 FLUE SYSTEM	4
7.0 AIR SUPPLY	5
8.0 WATER CIRCULATION SYSTEM	5
9.0 ELECTRICAL SUPPLY	8
10.0 INSTALLATION OF BOILERS	8
11.0 COMMISSIONING AND TESTING	9
12.0 FAULT FINDING	10
13.0 SERVICING	12
14.0 REPLACEMENT OF FAILED COMPONENTS	14
 FIGURES:	
1. Schematic Arrangement of Water and Gas Pipework	17
2. Water Pressure Drops and Minimum Flow Rate	18
3. Path of Mains Cable	19
4. Wiring Diagram	20
5. Illustration of a Module	21
6. Gas Pressure Adjustment	22
7. Gas Controller Sequence Disc	23
8. Arrangement Drawing, Wessex 1 x 50, 2 x 50 and 3 x 50	24
9. Pilot Burner	25
10. Valve and Pipework Soundness Testing	26
11. Arrangement Drawing, Wessex 100 Compact	27
 APPENDIX	
Thermostat Range Adjustments	28
Recommended Spares	29



HAMWORTHY

heating products

1.0 INTRODUCTION

1.1 These instructions are for use with natural gas (Family 2) only, boilers MUST NOT use gas other than for which they were designed and built. The "Wessex" is a gas fired, fan assisted, open flued central heating/hot water boiler. Each burner/tube bank assembly is termed a module. Up to three boiler modules are arranged in a single casing, the multiple arrangements being termed batteries. Each battery may have common flue, water and gas connections.

The technical data for the various arrangements is given in Section 2.

The burner fitted to each module is of the fan assisted pre-mix type, and a separate interrupted gas fired pilot. Burner operation is initiated by a safety control box that incorporates flame rectification principles.

Each single boiler/battery is arranged for direct connection to the flue system. The flue outlets from more than one battery may be connected to a single chimney. No draught diverter is fitted to the single boiler/battery nor is a fixed diverter required in the flue system. However, a draught stabiliser is recommended for some installations (see Section 6.1).

The Wessex Boiler is floor mounted and is intended for heating of commercial and industrial premises. It may also be used to supply hot water for those premises via an indirect cylinder.

The module has a low thermal capacity and water flow rates must be maintained at or above the recommended levels shown in Section 8 and Fig. 2.

1.2 This boiler must be installed by a competent person holding 'CORGI' registration or equivalent.

All installations must conform to the relevant Gas Safety and Building Regulations. HSE requirements must also be taken into account when installing any equipment.

Failure to comply with the above may lead to Prosecution.

1.3 If the boiler is to be connected to an unvented (Pressurised) heating system, care must be taken to ensure all extra safety requirements are met and that the relevant interlocks will shut down the boiler(s) should a high or low pressure fault occur.

The Pressurisation unit must also incorporate a low level water switch which protects the water pumps and will directly or indirectly shut down the boiler plant should a low water condition occur.

Consideration should also be given to the maximum working pressure of the boiler as given in Section 2: TECHNICAL DATA. Consult Hamworthy Heating Technical Department for help or assistance if in doubt.

BOILER		WESSEX 1 x 50	WESSEX 2 x 50	WESSEX 3 x 50
HEAT INPUT (gross)	kW	59.5	119.0	178.5
	Btu/h	203,000	406,000	609,000
HEAT OUTPUT (gross)	kW	50.0	100.0	150.0
	Btu/h	170,600	341,200	511,800
GAS RATE	M ³ /h	5.56	11.1	16.7
	ft ³ /h	19.65	393.0	589.4
NOMINAL GAS INLET PRESSURE	mbar	20	20	20
GAS ORIFICE PRESSURE DROP	mbar	2.5	2.5	2.5
GAS ORIFICE DIAMETER	mm	9.0	9.0	9.0
MAX WATER PRESSURE	bar	5.9	5.9	5.9
WEIGHT (dry)	Kg	85	165	240
ELECTRICAL SUPPLY 240V ~ 50Hz		200W	400W	600W

NOTE! Wessex Compact 100 Technical Data is the same as the 2 x 50.

2.2 Technical Data Table



HAMWORTHY

heating products

2.0 TECHNICAL DATA

2.1 BOILER NOMENCLATURE

Wessex 1 x 50:- Single 50 kW Module.

Wessex 2 x 50:- Two 50 kW modules mounted horizontally in a common casing.

Wessex 3 x 50:- Three 50 kW modules mounted horizontally in a common casing.

Wessex 100 Compact:- Two 50 kW modules mounted vertically in a common casing.

For arrangement drawings of Wessex 1 x 50, 2 x 50 and 3 x 50 boilers refer to Fig 8.

For arrangement drawings of Wessex 100 Compact refer to Fig 11.

2.1.1 Wessex Compact

A series of compact boilers can be placed side by side and manifolded together (water and gas) to give a double decked bank of boiler modules. Each "compact" boiler unit has its own flue offtake and attention is drawn to Section 6 for flue recommendations which apply equally to this vertical arrangement.

Flue junctions specifically designed for the Wessex 100 Compact range are available to order, combining 2, 3 and 4 flue off-takes into a single connection (refer to Contracts Department).

The fully assembled boiler unit will be delivered on a wooden pallet with an overall protective covering.

Unpack the unit and return the pallet and bolting down components to Hamworthy Heating Limited, Poole.

3.0 GENERAL REQUIREMENTS

3.1 Related Documents - Gas Safety (Installations and Use) Regulations 1984, and (Amendment) Regulations 1990

It is Law that all gas appliances are installed by competent persons in accordance with the above regulations. Failure to install appliances correctly could lead to prosecution. It is in your own interest, and that of safety, to ensure that this law is complied with.

The installation of the boiler MUST be in accordance with the relevant requirements of the Gas Safety Regulations, Building Regulations, I.E.E. Regulations and the byelaws of the local water undertaking.

It should also be in accordance with any relevant requirements of the local gas region and local authority and the relevant recommendations of the following documents:

British Standards Codes of Practice

BS 6891: Installation of low pressure gas pipework of up to 28 mm (R1) in domestic premises. (For larger installations see IM/2, IM/5 and IM/16 below).

BS 6644: Installation of Gas Fired Hot Water Boilers - 60 kW to 2 mW.

BS 6700: Design, installation, testing and maintenance of services supplying water for domestic use.

BS 6880: Code of practice for low temperature hot water heating systems of output greater than 45 kW.

BS 3456: (CEE 10 Part 1, CEE 11 Part 1) Electrical Standards.

CP 342: Centralised hot water supply.

Part 1: Individual dwellings.

Part 2: Buildings other than individual dwellings.

British Gas Publications

IM/2: Purging procedures for non-domestic gas installations.

IM/5: Soundness testing procedures for industrial and commercial gas installations.

IM/11: Flues for commercial and industrial gas fired boilers and air heaters.

IM/16: Guidance notes on the installation of gas pipework. (Excluding domestic installations of 25 mm and below).

Health and Safety Executive

Guidance Note **PM5** - Automatically Controlled Steam and Hot Water Boilers

C.I.B.S.E. Publications

C.I.B.S.E. Guide

It is impractical in this document to specify all relevant information, but the following extracts from the above references are emphasized since failure to comply with these requirements will almost certainly result in an unsatisfactory installation.



HAMWORTHY

heating products

3.2 FEED WATER SUPPLY

If the boiler feed water has a high degree of hardness, it is recommended that the water be treated to prevent precipitation of scale or sludge in the boiler water passageways. Details of additives can be obtained from any reliable manufacturer of water treatment products or the local water authority.

It should be noted however, that even if the boiler water is of average hardness, not requiring treatment, subsequent draining of the system for repair or constant make-up water due to an undetected leak will cause additional deposits and gradual build-up of scale. It is essential therefore, that leaks are attended to promptly and draining is kept to an absolute minimum.

It is recommended that the system be flushed out at least twice with hot water before any water treatment is added. If any doubt exists regarding the internal cleanliness of an old system, consideration should be given to the fitting of a coarse filter in the return pipework to the boilers.

3.3 ADEQUATE WATER FLOW

See also Section 8.8.

The Hamworthy Wessex boiler is designed as a quick response, low water content unit, to run continuously with minimum or no operating problems. Care should be taken in the initial design and layout having due regard for adequate water flow through the boilers and the influence of the system controls.

NOTE! The Standards Authority recommend a minimum return temperature of 50°C in all heating systems other than condensing boilers.

3.4 TIME CLOCK CONTROL

In order to avoid local overheating and progressive calcium deposition at zero flow conditions where boilers are operated from time clocks, provision should be made for a 3 minute circulating pump over-run after the last boiler has ceased firing.

NOTE! Time clocks should not interrupt live, neutral or earth connections. External voltage **MUST NOT** be applied to remote, stop/start terminals 5 and 6.

4.0 LOCATION

(See Fig.8 for dimensions/weights and clause 10.1 for clearances.)

The location chosen for the boiler must permit the provision of a satisfactory flue system and an adequate

air supply. The location must also provide adequate space for servicing and air circulation around each unit.

The boiler must be installed on a level non-combustible surface that is capable of adequately supporting its weight (when filled with water) and any ancillary equipment.

Any combustible material adjacent to the boiler and the flue system must be so placed or shielded as to ensure that its temperature does not exceed 65°C (150°F)

Further details regarding boiler location are given in BS 6644.

5.0 GAS SUPPLY

5.1 SERVICE PIPES

The local gas region must be consulted at the installation planning stage in order to establish the availability of an adequate supply of gas.

An existing service pipe must not be used without prior consultation with the local gas region.

5.2 METERS

A new gas meter will be connected to the service pipe by the local gas region, or a local gas region contractor.

An existing meter should be checked, preferably by the gas region, to ensure that it is adequate to deal with the rate of gas supply required.

5.3 GAS SUPPLY PIPES

Supply pipes must be fitted in accordance with BS 6891 or IM/16 as appropriate. Pipework from the meter to the boiler must be of adequate size. Do not use pipes of a smaller size than the boiler gas connection. The complete installation must be purged and tested for soundness as described in BS 6891 or IM/2 and IM/5 as appropriate.

5.4 BOOSTED SUPPLIES

Where it is necessary to employ a gas pressure booster, the controls must include a low pressure cut-off switch at the booster inlet. The local gas region must be consulted before a gas pressure booster is fitted.

5.5 BOILER HOUSE CONTROL VALVE

A manual valve for boiler house isolation shall be fitted in the gas supply line. It shall be clearly identified and readily accessible for operation.



HAMWORTHY
heating products

BOILER	EXHAUST VOLUME AT N.T.P.(0°C-760mm kg) 9% CO ₂		EXHAUST TEMP.		FLUE SIZE	
	m ³ /h	ft ³ /h	°C	°F	I.D. mm	NOM in.
WESSEX 1 x 50	72	2535	125	127	184	6
WESSEX 2 x 50	144	2535	125	257	184	6
WESSEX 3 x 50	216	7600	125	257	288	10

5.6 BOILER GAS SYSTEM LEAK CHECK

Although the boiler receives a gas leak check and gas train component integrity check prior to leaving the factory, transport and installation may cause disturbance to unions, fittings and gas valve assemblies etc. and during commissioning a further test for soundness should be carried out on the boiler gas pipework and components. A procedure guide is given in Fig.10. Care must be taken not to allow soapy water on or near any electrical parts or connections.

6.0 FLUE SYSTEM

Detailed recommendations for flue systems are given in **BS 6644**, British Gas Publication, IM/11 "Flues for Commercial and Industrial gas fired boilers and air heaters".

The following notes are intended to give general guidance only.

6.1 SUCTION

Each boiler/battery is arranged for direct connection to the flue system. The flue outlets from more than one battery may be connected to a single chimney. No draught diverter is fitted to the single boiler/battery nor is a fixed diverter required in the flue system. However, a draught stabiliser is recommended for some installations.

The flue system should be designed to maintain atmospheric pressure or a slight suction at the single boiler/battery flue connection at all times. If at any time the suction is likely to exceed 0.1 mbar (0.04 in. w.g.) a draught stabiliser is recommended to be fitted to the flue system.

6.2 DESIGN WASTE GAS VOLUME AND TEMPERATURE

It is recommended that the volume and temperature of the waste gases shown above are used for the design of the flue system.

6.3 FLUE CONDENSATION

With the high thermal efficiency of the boiler, the flue gas temperature is low (approx.125°C). Condensation in the flue is thus more likely than with lower efficiency units. It is strongly recommended that twin-wall or insulated flue pipe is used on all installations. Care should be taken to ensure that the flue is installed such that any condensation is continuously drained. All flues should have a minimum slope of 2½° upwards in the direction of exhaust gas flow (no horizontal sections). All joints should be such that any condensation is directed back down the slope. The drain fitted to the boiler casing is 19 mm O/D (16 mm I/D) and will take a ¾ in O/D tube compression fitting (WADE etc); it will adequately cope with condensation from 6 m (20 ft) of twin-wall flue, any longer lengths of flue should have separate open drain connections. The drain pipe must be 15.0 mm (½ in) dia. minimum, having a fall of at least 3° (approx. 5 cm per metre) and be of non-corrosive material and led to a gully via a waste trap.

6.4 MATERIALS

Materials used for the flue system must be asbestos free, mechanically robust, resistant to internal and external corrosion, non-combustible and durable under the conditions to which they are likely to be subjected.

6.5 DISCONNECTION

Facilities must be made for disconnecting the flue pipe from each single boiler/battery for inspection and servicing purposes. Bends with removable covers should be fitted for inspection and cleaning purposes where considered appropriate. Flues must be adequately supported and protected from damage. They must not present a risk to people in or about the building.

6.6 FLUE DISCHARGE

The flue system must ensure safe and efficient operation of the boiler to which it is attached, protect the



HAMWORTHY

heating products

combustion process from wind effects and disperse the products of combustion to the external air.

The flue must terminate in a freely exposed position and be so situated as to prevent the products of combustion entering any opening in a building.

Where the flue diameter is less than 200 mm (8 in) a terminal should be fitted. Where the flue is of a larger size consideration should be given to the fitting of a terminal.

6.7 SURFACE TEMPERATURES

Combustible materials in the vicinity of the boiler and flue shall not exceed 65°C during boiler operation. The flue shall not be closer than 50 mm to any combustible material, except where it passes through such material with a non-combustible sleeve when the air gap may not be less than 25 mm.

6.8 FLUE PIPE LOCATION

The flue must not be placed or fitted where there is undue risk of accidental damage to the flue pipe or undue danger to persons in the vicinity.

7.0 AIR SUPPLY

Boiler Installations up to 33 Modules - 1.65 MW Output (2 MW Input)

Detailed recommendations for air supply are given in BS 6644 Claus 19.

The following notes are intended to give general guidance. In all cases there must be provision for an adequate supply of air for both combustion and general ventilation, in addition to that required for any other appliance.

7.1 AIR SUPPLY BY NATURAL VENTILATION

The purpose provided space housing the boiler must have, or be provided with, permanent air vents communicating directly with the outside air, at high level and at low level. Where communication with the outside air is only possible by means of high level air vents, ducting down to floor level for the lower vents should be used. For an exposed boiler house, air vents should be fitted preferably on all four sides, but at least on two sides. Air vents should have negligible resistance and must not be sited in any position where they are likely to be easily blocked or flooded or in any position adjacent to an extraction system which is carrying flammable vapour. Grilles or louvres must be so designed that high velocity air streams do not occur within the space housing the boiler. The grilles shall have a total minimum free area as

follows -

Low Level (inlet) - 540 cm² plus 4.5 cm² per kilowatt in excess of 60 kW total rated input.

High Level (outlet) - 270 cm² plus 2.25 cm² per kilowatt in excess of 60 kW total rated input.

1The air supplied for boiler house ventilation shall not allow the boiler house temperature to exceed 25°C at floor level, 32°C at mid-level and 40°C at ceiling level during the heating season.

7.2 AIR SUPPLY BY MECHANICAL VENTILATION

The supply of air to a space housing the boiler by mechanical means should be by mechanical inlet with natural or mechanical extraction. Mechanical extract ventilation with natural inlet must not be used.

The requirements of air supply by mechanical ventilation are per 50 kW module as follows:-

Inlet air - 162 m³/h (minimum)

Extract air - 108 m³/h

NOTE: For mechanical ventilation systems an automatic control should be provided to cut off the gas supply to the boiler, in the event of failure of air flow in either inlet or extract fans.

8.0 WATER CIRCULATION SYSTEM

8.1 GENERAL

The boiler has a low water content and the requirements of minimum water flow are given in Section 8.8 and Fig. 2. Recommendations for the water circulation system are given in BS 6644 and CP 342.

The following notes are of particular importance.

In a combined central heating and hot water system, the hot water storage vessel must be of the indirect cylinder or calorifier type. The hot water storage vessel should be insulated preferably with not less than 75 mm (3 in.) thick mineral fibre, or its thermal equivalent.

Circulating pipework not forming part of the useful heating surface should be insulated to help prevent heat loss and possible freezing, particularly where pipes are run through roof spaces and ventilated cavities. Cisterns situated in areas which may be exposed to freezing conditions, should also be insulated.

Insulation exposed to the weather should be rendered waterproof. Draining taps must be located in accessible positions which permit the draining of the whole system,



HAMWORTHY

heating products

including the boiler and hot water storage vessel.

3.2 PRESSURE RELIEF VALVE (SAFETY VALVE)

The most important single safety device fitted to a boiler is its safety valve and each boiler, or in the case of modular installations, each bank of boilers, must be fitted with a pressure relief valve to BS5759 or BS 6759 Part 1 (ISO4126) and sized as in BS 6644 (See note to 1.0 Introduction).

BS 6644 provides comprehensive information for the selection and location of safety valves and attention is drawn to the higher capacity requirements of safety valves for pressurised hot water systems.

3.3 OPEN VENT PIPE AND COLD FEED PIPE

(See BS 6644) Ref: Fig 1 for the open vent connection.

A vent pipe and cold feed pipe must be fitted to the water system between the single boiler/battery and the first isolating valve in the water system. The sizes of these pipes are shown below.

The vent pipe must rise continually, must not be valved except by a design which when closed for maintenance the boiler is open to atmosphere. The pipe shall be protected against freezing where this might occur.

3.4 ALTITUDE GAUGE (WATER PRESSURE GAUGE)

See Fig. 1 for position of tapping.

Each single boiler/battery should be provided with a gauge complete with isolating cock.

3.5 THERMOMETER

See Fig. 1 for position of tapping.

A thermometer complete with pocket should be fitted in the pipework to indicate water flow temperature.

8.6 DRAIN TAPS

See Fig. 1 for position of tapping.

Each single boiler/battery must have a ½ in. n.b. drain tap fitted to drain the single boiler/battery only.

8.7 CIRCULATING PUMP

One or more circulating pumps will be required to circulate the boilers and heating system. Fig. 2 shows the hydraulic resistance of the single boiler/battery. The pump should be sited to facilitate servicing. It is important to note that when Wessex boilers are used to replace boilers on an existing system, the pumps should be checked for performance against the new boiler waterside pressure drop to ensure that the minimum flow rate can be obtained. It is also important that the existing system be flushed through to remove any loose matter which may have accumulated. If in any doubt regarding the cleanliness of the system, a coarse filter should be fitted in the return pipework to the boilers.

8.8 MINIMUM WATER FLOW RATES

The minimum water flow rates are shown in Fig. 2. These flow rates should be maintained through each single boiler/battery at all times when the boiler is firing. If the water flow rate is allowed to fall below the minimum then the water ways of the boiler might be subject to premature failure due to scale formation. Particular attention should be paid to the restriction of external flow circuits during periods of low heat demand.

8.9 WATERSIDE PRESSURE DROP

The water side pressure drop is shown in Fig. 2.

NOTE: If boilers are run off time clock control, a pump overrun (not H.H.L. supply) should be fitted which must run for minimum of 3 minute on shut-down of the boiler.

Boiler	PRESSURE RELIEF VALVE	OPEN VENT & COLD FEED PIPE	
	Safety Valve	Open Vent Size	Cold Feed Size
Wessex 1 x 50	Minimum clear bore 19 mm Dia. 284 mm Area	25 mm (1 in)	20 mm (¾ in)
Wessex 2 x 50		32 mm (1¼ in)	25 mm (1 in)
Wessex 3 x 50		38 mm (1½ in)	32 mm (1¼ in)



HAMWORTHY heating products

8.10 CONTROL SCHEMES

8.10.1. Temperature Controls

An adjustable control thermostat is supplied fitted to each module, being set to operate within the range 65-90°C for standard applications. If a higher water temperature is required (and provided sufficient head on the water system is available) the thermostat may be adjusted to operate in excess of 90°C.

For thermostat adjustment procedure see Appendix 1. See Note to 1.0 Introduction.

For high temperature applications, a "special to contract" controls thermostat is available with a higher range and it should be noted that on boilers applied to systems having flow temperatures in excess of 100°C, additional insulation should be applied to the front heat exchanger tube plates (apply to Hamworthy Heating for this special insulation kit). See Note to 1.0 Introduction.

A temperature limiter (hand reset limit thermostat) is also fitted to the module and is normally set at 100°C.

NOTE: Standard temperature limiter setting = 105°C (MAX).

The minimum difference between control thermostat and temperature limiter must not be less than 10°C.

8.10.2 Water Flow Controls

Any external mixing valves or similar controls should always ensure that the minimum water flow rate shown in Fig. 2 is maintained. It is recommended that a water flow switch is fitted to the system. The switch should be connected such that the boiler cannot fire unless the water flow is proved.

When multiple boilers are installed it is recommended that the water pipework is connected using the reverse flow principle to ensure equal flow through all boilers

8.10.3 Frost Protection

Consideration should be given to fitting a frost thermostat set at approximately 4°C (39°F).

8.11 MINIMUM WATER SYSTEM PRESSURE

To comply with Guidance Note PM5 from the Health and Safety Executive the minimum static water pressure at the highest point in the circulating system must be calculated as follows:-

If the boilers are to be installed as single units the minimum pressure must be equal to the gauge pressure equivalent to the saturated steam temperature obtained

by adding 17°C to the required boiler flow temperature but never less than 2 m (6.5 ft).

e.g.1	Required Flow Temp.	= 90°C
	Safety Margin	= 17°C
	Equivalent Saturated Steam Temp	= 107°C

From Steam Tables -
Corresponding Gauge Pressure
= 0.3 bar (4.1 psi)
= 2.87 m (9.4 ft)
head of water

If the boilers are to be installed in a modular formation the minimum pressure must be equal to the gauge pressure equivalent to the saturated steam temperature obtained by adding 17°C to the sum of the required mixed flow temperature and the temperature rise across the boilers.

e.g.2.	Required mixed flow Temp	= 82°C
	Temp. rise across boilers	= 11°C
	Safety margin	= 17°C

Equivalent Saturated Steam Temp	= 110°C
---------------------------------	---------

From Steam Tables -
corresponding Gauge Pressure
= 0.42 bar (6.1 psi)
= 4.3 m (14 ft)
head of water

e.g.3.	Required mixed flow Temp.	= 82°C
	Temp. rise across boilers at minimum flow	= 13°C
	Safety margin	= 17°C

Equivalent Saturated Steam Temp	= 112°C
---------------------------------	---------

From Steam Tables -
corresponding Gauge Pressure
= 9.57 bar (8.3 psi)
= 5.8 m (19.1 ft)
head of water

8.12 UNVENTED PRESSURISED SYSTEMS

See Fig 1/Page 17 for typical layout of a Pressurised (Unvented) Hot Water System).

In order to correctly size a Pressurisation Unit for any Heating System certain parameters are required. These are:-

1. Static height of highest component in system.



HAMWORTHY heating products

2. System volume - if not known a general rule of thumb of 10 litres/kW installed boiler power can be used.
3. Maximum flow temperature, ie most systems run at 82°C.
4. Maximum system hot working pressure, generally given in bar gauge.

From the above information Hamworthy Heating can size the pressurisation unit and also the expansion vessel required.

Care must be taken in sizing expansion vessels to ensure maximum acceptance factors are not exceeded. Normally manufacturers of vessels impose a limit of 0.5. This value must not be exceeded at any time during the operation of the boiler: this includes the over pressure condition should a safety valve lift.

Consideration should also be given to sizing of the safety valve(s) in the system. See BS6759 Part 1 (ISO 4126) for information.

See also BS 6880 Part 1 for design considerations.

9.0 ELECTRICAL SUPPLY

See BS 6644

WARNING: THIS APPLIANCE MUST BE EARTHED.

Wiring external to the boiler must be installed in accordance with the I.E.E. Regulations and any local regulations which apply. Wiring must be completed in heat resistant 3 core cable. (Size 1,0 square mm C.S.A.). Boilers are normally supplied for 240 volts, 50 Hz. Internal fuse rating of each module is 2A. External fuses should be 5A for all single boiler/battery sizes.

The method of connection to the mains electricity supply must facilitate complete electrical isolation of the single boiler/battery with a contact separation of at least 3 mm in all poles.

A mains isolator must be provided adjacent to the boiler in a readily accessible position. The supply should only serve the boiler. Further details regarding connection to the electricity supply are given in BS 3456 (CEE 10 Part 1, CEE 11 Part 1)

NOTE: Volt free contacts electrical supplies must also be isolated when fitted (see note on fascia).

9.1 MAINS CABLE CONNECTION

The path of the mains cable is shown in Fig. 3. The length of the conductors between the cord and anchorage and the terminals must be such that the

current carrying conductors become taut before the earthing conductor, if the cable or cord slips out at the cord anchorage.

9.2 MODULE WIRING DIAGRAM

The module wiring diagram is shown in Fig. 4. This wiring diagram is also fitted inside each module cover.

10.0 INSTALLATION OF BOILERS

10.1 GENERAL

Each boiler/battery is normally despatched to site as a pre-piped unit for floor mounting. All units should be stored in a weatherproof place before installation.

The single boiler/battery should be positioned to allow minimum clearance of 150 mm (6 in) from adjacent walls or equipment to facilitate inspection and 400 mm at the front for cover removal.

Other installation dimensions are given in Fig. 8.

The outer insulated casing should be fitted in accordance with the packed instructions after completing the gas and water pipework connections, but prior to connecting the boilers to the flue system. Care must be taken to prevent damage to the casings prior to contract completion.

10.2 CONNECTION OF BOILERS TO FLUE SYSTEM

Notes on the recommendation for design of the flue system are given in Section 6.

Each single boiler/battery is arranged for direct connection to the flue system. The flue outlets from more than one battery may be connected to a single chimney. No draught diverter is fitted to the single boiler/battery nor is a fixed diverter required in the flue system.

A flue socket is provided suitable for accepting twin-wall flue pipe. Sealing of the flue to the socket should be made using a suitable caulking string and cold caulking compound.

Suitable means should be incorporated in the flue system adjacent to the boiler for removal of the boiler casing without the need to dismantle the whole flue system.

10.3 GAS CONNECTIONS

For design see Section 5.

Size and position of gas connections are shown in Fig. 8. A filter mesh is fitted inside the gas cock at the union end. Each module has an individual gas cock fitted. The installer must fit a suitable isolation valve on the supply to each boiler/battery as shown in Fig. 1. A union should



HAMWORTHY

heating products

be fitted between the isolation valve and the boiler/battery manifold for ease of battery removal.

11.0 COMMISSIONING AND TESTING

Before attempting to commission any boiler or module ensure that personnel involved are aware of what action is about to be taken and begin by making the following checks:

- a) Flueway passages to chimney are clear.
- b) Flueway passages in the boiler are clear and clean.
- c) Adequate ventilation, as per Section 7, exists in the boiler house.
- d) The system is fully charged with water, ready to receive heat and all necessary valves are open.
- e) The pipework and valve arrangement is installed to Hamworthy recommendations in such a way that adequate water flow rates will be present in boiler in accordance with Fig. 2.
- f) The gas supply pipework is clear of any loose matter.

11.1 ELECTRICAL INSTALLATION

For design see Section 9.

Wiring must be checked by a suitably competent person.

Normal supply required is 240 V 50 Hz single phase supply. An isolator correctly fused at 5 amps should be cited close to the boiler.

Any other interlocks ie pressurisation unit, BEM system should be wired in series with the remote start/stop loop.

A schematic of the circuit is shown in Fig 4.

11.2 GAS INSTALLATION

For design see Section 5.

The whole of the gas installation, including the meter, must be inspected and tested for soundness and purged in accordance with the recommendations of BS 6891 or IM/2 or IM/5 as appropriate.

11.3 WATER CIRCULATION SYSTEM

For design see Section 8.

NOTE: If a boiler is to be fitted into an old or existing pipework system it is advisable that this is chemically cleaned and thoroughly flushed prior to plant commissioning. When flushing the system ensure that all valves are open and all unreasonable restrictions removed. (circulating pumps etc.).

After flushing, the system should be re-instated, filled and vented. Before proceeding to initial commissioning,

the total water system should be checked for soundness.

11.4 LIGHTING THE BOILER (INITIAL COMMISSIONING)

Prior to delivery, all Wessex Boilers are subject to a full sequence check and pressure switches are adjusted to design settings. (See following text for values) The intent therefore of the following initial commissioning procedure, is to check the correct functioning of the sequence system up to and including the establishment of the pilot flame, with the gas supply to the main burner isolated.

- a) Ensure that the gas supply to each module is turned ON.
- b) Isolate the electrical supply to the boiler (plant switch).
- c) Remove the boiler front cover. Disconnect the orange flame probe lead from the flame probe and control bracket connection and replace with a micro amp meter.
- d) Turn each boiler switch to off and adjust the boiler control thermostat to minimum setting.
- e) Disconnect the main gas solenoid valves by removing the electrical commissioning loop between terminals 1 and 2 on the incoming supply terminal block. (See wiring diagram).
- f) Establish water flow through the boiler modules (circulating pumps).
- g) Ensure electrical supply to boiler is ON, then switch boiler ON/OFF switch to ON after which the controller should commence an automatic sequence of events. If when the switch is turned to ON it is observed that the lock-out lamp on the sequence step controller is illuminated, the controller should be re-set by depressing the illuminated button.
- h) With the controller re-set from lock-out, the cam timer will motor to its normal start position and the fan will commence a boiler pre-purge of approximately 40 seconds.
- i) Following this pre-purge period, an ignition spark will be generated and the pilot gas solenoid valve will lift to supply gas to the pilot burner.
- j) After a few seconds, the spark will be removed and a short pilot flame monitoring period will start. The pilot flame proving signal should be 2.5 - 5.0 μ A.
- k) On completion of the pilot proving period, the green normal firing lamp will be seen to illuminate but since the main gas solenoid valves are disconnected, the boiler sequencer will go to lock-out after approximately 4 seconds. The lock-out lamp on the controller will then illuminate and the green normal firing lamp will be extinguished.
- l) When the commissioning engineer is satisfied that he has a stable reliable pilot flame, the module should be electrically isolated at the plant switch and the



HAMWORTHY heating products

commissioning loop reconnected. (Terminals 1 and 2 on the incoming supply terminal block).

Main Burner Commissioning:

m) Having established a satisfactory pilot flame and reconnected the supply to the main gas solenoid valve, the sequence described above will, after switching the boiler on, be repeated but instead of the boiler going to lock-out at the end of the pilot proving period, the main gas valve will open and after approximately 4 seconds of green lamp illumination, the pilot valve will be de-energised and the main flame should remain established under the control of the flame monitoring system. The main flame proving signal should be 25-35 μ A.

Turn the boiler switch and electrical isolator to off, remove the micro ampmeter, reconnect the orange flame probe connections.

Burner pre-mix system leakage check. (Using a Gasco-Seeker).

n) With the burner/controls casing on and all tests for soundness carried out, light the boiler and wait for five minutes. With a suitable gas detector, insert the probe into the circular viewing port on the right hand front of the casing and test at insertion depths of 50 mm (2 in.) and 150 mm (6 in.) within the casing. Also conduct tests at 100 mm (4 in.) intervals around the casing where it fits to the boiler and at any case openings. (NB. The detector probe should be held approximately 13 mm (0.5 in.) from the casing joint when testing outside the casing.)

If the gas reading in the casing does not exceed 25% LEL and there is no gas detected outside the casing, any leakage from the pre-mix system is acceptable. If the gas reading in the casing exceeds 25% LEL at either point or gas is detected outside the casing, the leakage must be located and sealed and the tests repeated.

11.5.1 Gas Pressure Adjustment

After approximately 30 minutes of normal firing, the gas pressure differential across the gas orifice (reference Figure 6) should be checked by connecting a differential manometer to test points A & B. The pressure drop for Natural Gas should be 2.5 mbar (1 in. w.g.) and minor adjustments to the appliance governor may be necessary to correct for site gas pressure conditions.

NOTE: The above is a first order check. Final Setting must be made using a gas meter.

For reference, the air pressure switch setting (factory adjusted) is 1.25 mbar (0.5 in. w.g.) to "break". It must not be adjusted from this set point.

11.5.2 Combustion Checks

A flue gas sampling point is provided in the front boiler casing (see Fig. 5). To check combustion take a flue gas sample from each module test point and for reference North Sea Natural Gas CO₂ measurements should be between 9 and 10% or 3.5 to 5% when the basis of measurement is oxygen. Normal CO levels should not exceed 200 ppm or 0.02% (by volume).

NOTE: All the above measurements refer to dry gas samples.

11.6.1 Temperature Limiter

The limit thermostat is supplied factory set to 100°C and this is normally satisfactory for low pressure hot water systems.

NOTE: For high temperature applications, it is essential that the water system static head or in the case of pressurised systems, the system pressure, is suitable for operation at elevated temperature and attention is drawn to the specific requirements of BS 6644 and the Health and Safety Executive Guidance Note PM5 (Automatically Controlled Steam and Hot Water Boilers). Refer also to section 8.11.

11.6.2 Control Thermostat Adjustment

Control thermostats are factory set to limit their adjustment to 90°C, however, the thermostat maybe adjusted to operate in excess of this temperature.

NOTE: Standard temperature limiter setting = 105°C (MAX). The minimum difference between control thermostat and temperature limiter must not be less than 10°C.

11.7 USERS INSTRUCTIONS

Upon satisfactory completion of commissioning and testing, the commissioning engineer should hand the Users Instructions to the user or purchaser and explain the method of economic and efficient operation of the system. Ensure that the user or purchaser is fully conversant with lighting, shutdown and general operational and emergency procedures.

12.0 FAULT FINDING

The controller fitted to the Wessex 50 kW boiler incorporates a rotating coloured disc fixed to the cam timer which provides information with regard to the position that has been achieved at any point in the sequence. This disc with the relevant sequence information is shown in Fig. 7 and in general the fault can be located by observing the position at which the



HAMWORTHY

heating products

disc stopped rotating and the functions controlled to that point.

BOILER SEQUENCE CONTROLLER, OPERATION AND FAULT FINDING:

12.1 SUMMARY OF SAFETY FEATURES

1. Flame failure during a run, results in burner shutdown and lockout within 1 second.
2. Failure to establish and detect flame during the light-up sequence, results in burner shutdown and lockout within 2-5 seconds from the initial release of fuel.
3. Air supply failure at any time, results in burner shutdown and immediate lockout.
4. The air pressure proving switch, is checked in both the "no air" and "air supply proved" positions.

From the initial start up of the burner fan motor, a period of 5 seconds is allowed by the control box for the pressure switch to detect a combustion air supply.

5. Restoration of the power supply after an interruption, results in a full light-up sequence to safely restart the burner. Power failure after a lockout, will not interfere with this condition when the supply has been restored.
6. False flame signals at the start point and during pre-purge results in burner shutdown and lockout.
7. The light-up sequence can only commence providing the cam switches and relay contacts within the control box are at their correct relative positions, and continuity of the lockout relay circuit is proved.

12.2 FAULT FINDING

1. Burner will not start - Coloured programme indicator stopped on blue line in white sector:

- a) Check electrical supply is switched on.
- b) Check that thermostat circuit is "calling for heat" and timeswitch circuit (if fitted) is made. A supply on terminal 9 will determine this.
- c) Check that the start circuit loop across terminals 9 and 1 is made.

2. Burner will not start. Synchronous motor runs, coloured programme indicator rotates but burner does not start:

- a) Check air pressure proving switch is in correct state i.e. "no air" position.

3. Burner starts but goes to lockout. Programme indicator stopped on red line in blue sector.

- a) Check air pressure proving switch.
- b) Check that a load, e.g. start gas valve is connected to terminal C.
- c) Check continuity of start gas coil winding.
- d) Check for flame simulation or false flame signal.

4. Burner starts but goes to lockout. Coloured programme indicator stopped in blue sector:

- a) Check for combustion air supply failure.
- b) Check for flame simulation, if necessary, change control box.
- c) Check for continuity of start gas valve coil circuit.

5. Burner starts, flame established but control box goes to lockout. Coloured programme indicator stopped at end of yellow sector/start of red sector.

- a) Check that flame detection probe is in contact with flame.
- b) Check that flame probe insulator is not cracked. A cracked insulator will be sufficient to give rise to an a.c. leakage current.
- c) Check that flame probe is not in contact with other metallic parts of the burner.

6. Burner starts, flame established but control box goes to lockout. Coloured programme indicator stopped in red sector.

- a) Check that when main gas valve has been switched on the change in combustion or flame characteristics has not caused the flame to "lift off" the combustion head and hence allow the flame probe to lose contact with the flame.

7. Burner starts, runs but subsequently goes to lockout. Coloured programme indicator stopped at end of green/start of white sector.

- a) Check for interruption in gas supply.
- b) Check for failure of combustion air supply failure.
- c) Check flame probe position for proper contact with flame.
- d) Check flame probe insulator for soundness.
- e) If necessary change control box.

NOTE: If the control box goes to lockout, it is generally performing the function it is designed for.

12.3 CAUSES OF LOCKOUT

1. No ignition.
2. Ignition not in correct place, check electrode settings and ceramic insulator for cracks or damage.
3. No gas supply.



HAMWORTHY

heating products

4. Gas valves not opening.
5. Failure of combustion air supply.
6. Incorrectly positioned flame probe, poor earth contact with flame, interference to flame signal from ignition spark.
7. Faulty control box.

13.0 SERVICING INSTRUCTIONS

13.1 GENERAL

Regular periodic servicing is recommended, preferably by a Hamworthy appointed person.

WARNING: ISOLATE THE ELECTRICAL SUPPLY TO THE SINGLE BOILER/BATTERY BEFORE ANY SERVICING OR COMPONENT EXCHANGE PROCEDURE, AND TURN OFF THE GAS SERVICE COCK TO THE MODULE BEING SERVICED.

VOLT FREE CONTACT ELECTRICAL SUPPLIES MUST ALSO BE ISOLATED WHEN FITTED.

13.2 ANNUAL SERVICE

NOTE: A competent plant maintenance engineer should check and ensure that the flue, its supports and terminal, the ventilation to the boiler house, safety valve, drain, water filter if fitted, pressure gauge, etc. are in a serviceable and working condition and still comply with the relevant and aforementioned standards and Codes of Practice.

13.2.1 Remove module cover by unscrewing the central 'posidrive' retaining screw and withdrawing cover from the two corner locating pins.

13.2.2 Remove fan/mixing chamber and control assembly complete using the following steps:

- a) Disconnect mains cable at terminal block and earthing post, loosen cable clamp and withdraw cable from assembly.
- b) Disconnect leads to spark electrode and flame probe.
- c) Release pilot bundy tube from solenoid valve body.
- d) Release ½ in. union nut connecting gas services cock to module. Clean gas filter by blowing over it.
- e) Release gas pipework "U" bolt located just above service cock by slackening the two M6 nuts and removing the M10 nut securing the plate to the module casing stud. Swing pipe clamp plate away from stud.
- f) Remove wire retaining clip from thermostat pocket and withdraw thermostat bulbs.
- g) Remove air pressure switch cover plate, disconnect wiring and remove switch from module by releasing bundy tube nuts at top of switch and underside of fan case.
- h) Release pilot burner assembly by removing the two screws securing it to the header casing, and withdrawing unit.

- i) Unscrew the four M5 nuts securing the complete assembly to the front header casting, release the earthing strip from the stud and withdraw assembly from the module including the square gasket and earthing strip.
- j) The burner can now also be withdrawn from the module by first tapping lightly on the flange to loosen. The centre cone can be gripped with pliers to facilitate withdrawal.

13.2.3 Clean the burner by gently brushing inner and outer surfaces and tap firmly, flange downwards, on a wooden block to eject particles of dust and debris. If the burner cone is removed to assist cleaning by extracting the three split pins, they must be replaced by new split pins (Hamworthy Part No. 339012687). Check circular cork gasket for soundness and renew if necessary. Replace burner in module. (Closed end of burner must locate in recess in module rear tube plate.) This will be indicated when the flanged end of the burner is flush and square with the front header casting. The burner flange marking "Top MK IV" MUST BE AT THE TOP when assembled to the heat exchanger.

13.2.4 The fan/mixing chamber, controls assembly and pilot assembly may now be removed to bench for inspection and cleaning.

a) Release the screw retaining the sequence controller and pull the top clear of the base plate to expose the wiring terminal rail. Disconnect and remove the two black fan motor leads from terminals 4 and 8. Release the fan motor earth lead (green/yellow) from the boiler earthing post.

b) Remove circlips securing solenoid coils on main electromagnetic gas valve and withdraw coils.

c) Remove clip securing pilot valve coil and lift coil from body.

d) Remove the three 'posidrive' screws securing fan motor plate and thermostat/indication lamp bracket, to fan casing. Remove bracket and wiring loom complete with solenoid enclosures. Gently withdraw fan taking care not to damage rubber gasket. The fan motor bearings are sealed for life and do not require lubrication.

e) Gently brush fan blades if necessary to remove any dust accumulation.

f) Gently brush both sides of the swirler - (located between fan discharge flange and extension duct) - to remove any dust accumulation.

NOTE: Exercise extreme caution at this stage as the swirler must not be damaged or altered in any way. Do not attempt to remove swirler from its location.



HAMWORTHY heating products

g) Remove bundy tubes from air pressure switch and blow them and their respective couplings through to ensure they are clear. Remove couplings from air switch and blow through. (Do not attempt to blow through whilst fitted to switch - to prevent damage to switch diaphragm.)

h) Re-assemble fan/mixing chamber etc., by reversing the above procedure.

13.2.5 Gently lift filter gauze from gas cock and lightly brush off or blow away any dust and debris - replace immediately.

13.2.6 Check spark electrode assembly. If electrode shows signs of oxidization or is distorted it must be renewed. Check that spark gap is set at 3 mm.

13.2.7 Check flame probe for signs of oxidation or distortion - renew if required. Probe length from tip to mounting flange must be 120 mm.

13.2.8 Remove pilot bundy tube from connection at pilot burner assembly. Blow through and clean tubing and re-assemble.

13.2.9 Re-assemble fan/mixing chamber and controls assembly to module in reverse procedure to that given in paragraph 13.2.2. Check rectangular cork gasket for serviceability and renew if required.

NOTE: Ensure earthing strip is in contact with the burner flange and on the stud under the spring washer and nut.

Use colour code given on wiring diagram (inside controls casing and Fig. 4 of this guide) to facilitate reconnection of electrical leads.

13.2.10 Replace module cover and tighten retaining screw.

13.2.11 Recommission boilers, ref. section 11.4 testing gas joints broken or disturbed for soundness before firing.

13.3 TWO YEAR SERVICE

13.3.1 Repeat annual service as previously described in paragraphs 13.2.1 to 13.2.8 inclusive but do not re-assemble any items to the boiler modules. If boiler is a 2 x 50 or 3 x 50 battery either:

- Turn off main gas supply to boiler, undo 1 in gas union and remove gas manifold or
- Temporarily support gas manifold.

13.3.2

a) Isolate the single boiler/battery from the flow and return water pipes and drain down. Each module holds

approximately 4 litres (0.9 gall) of water.

b) Undo and remove the four M12 bolts and nuts securing the modules flow and return flanges to respective headers and break the seal. If boiler is a 2 x 50 or 3 x 50 battery, undo flange bolts holding flow and return headers to respective pipework and remove headers.

c) Undo the four M10 nuts/studs securing the module to the battery casing and withdraw the module by sliding it out on the internal runners.

NOTE: Each module weighs approximately 45 kg (100 lb)

d) Take module to bench and stretch off stainless coil spring baffle retainers.

e) The 16 stainless steel baffle plates can now be removed to expose the finned tube bank. Wire brush both sides of baffles to remove any deposit.

f) Thoroughly wire brush finned tubes until clean.

13.3.3 Re-assemble modules generally in reverse procedure to above. Clean flanges and renew flange gaskets. Renew ceramic fibre rope seal - (Module casing). To re-assemble baffles, stretch coil spring retainer over tube bank then slip in baffles one at a time. All baffles have pressed locating dimples - ensure these baffles are positioned opposite one another around the tube bank to locate the retainers. When all baffles are in position, stretch second retainer over the assembly and locate between dimples.

When module is reassembled in casing, re-fit other items, i.e. ignition/pilot assembly, filter mesh, fan/mixing chamber and controls etc., in accordance with procedure for annual service. Continue with final items of annual service viz: 13.2.10 and 13.2.11.

13.4 FOUR YEAR SERVICE (and every subsequent four Years)

13.4.1 Repeat two year service procedure as described in paragraphs 13.3.1 and 13.3.2

13.4.2 With module on bench:

a) Remove the 12 x M10 bolts securing the inner cover plate to the inner tube plate and separate plates..

b) Remove the 12 x M10 bolts securing the front header plate to the outer tube plate and separate the plates.

c) Clean and descale the tubes and also the waterway in the tube plates and covers. Chemical



HAMWORTHY heating products

descaling is preferred for the tube bank assembly. Recommended solutions include "Gamlen XD" Blended with Gamlen C.U.O. inhibitor. *Fraser D S 10*

Follow chemical manufacturers instructions for solution strength, method of application, safety and handling precautions.

13.4.3 Clean up mating surfaces and re-assemble covers to tube plates (ensuring markers 'Δ' line up) with new gaskets, lightly greased, before assembly. Torque M10 bolts evenly to 5.5 kg.m. (40 lb ft).

13.4.4 Continue with re-assembly according to paragraph 13.3.3, concluding with final items of annual service viz. 13.2.10 and 13.2.11.

13.4.5 When the module is firing the gas pressure must be checked in accordance with paragraph 11.5 (Commissioning and Testing section).

14.0 REPLACEMENT OF FAILED COMPONENTS

Refer to wiring diagram on the boiler and on the underside of the controller when reconnecting component connectors.

WARNINGS:

1) Isolate the electrical supply to the single boiler/battery and turn off the gas supply before removing burner cover and commencing any servicing or component exchange procedure.

2) With components of a plug-in design a hazard may result if they are interchanged with other components in the control system, or replaced by incorrect components.

14.1 SPARK ELECTRODE RENEWAL (Hamworthy Part No. 333801341)

a) Pull off H.T. cap and disconnect probe wire. Release nuts securing bundy tube between pilot solenoid valve and assembly and remove. Remove two screws securing pilot assembly to header casing and withdraw assembly.

b) Release electrode by removing screw securing its flange to the assembly.

c) Check spark gap is set at 3 mm before re-fitting assembly to boiler.

d) Start and stop the boiler several times to check the reliability.

14.2 FLAME PROBE RENEWAL (Hamworthy Part No. 333801333)

a) Repeat Step 14.1 a) above.

b) Release probe by removing screw securing its flange to the assembly.

c) Check rod of new probe for straightness and length (see 13.2.7) before re-fitting to assembly.

d) Run the boiler and check flame proving current (see 11.4 j) and m)).

14.3 SIGHT GLASS RENEWAL (Hamworthy Part No. 339907043)

a) Repeat Step 14.1 a) above

b) Remove spark electrode and flame probe. Lift out clamp-ring and remove sight glass disc from igniter block. Replace in reverse order with particular attention to 14.1 c).

14.4 FAN MOTOR RENEWAL (Hamworthy Part No. 339011085)

Release the screw retaining the sequence controller and pull the top clear of the baseplate to expose the wiring terminal rail. The two fan leads (both black) are interchangeable, one of which is wired into terminal No. 4, the other to the neutral (terminal No. 8). Withdraw the wires from the controller, then release and remove the motor earthing cable (yellow/green) from the earthing post on the burner control bracket. Remove the three posihead screws holding the fan motor plate and thermostat/indicator lamp fascia etc., to the fan casing. Place the fascia to one side ensuring no excessive strain is put on any wiring connections or thermostat capillaries.

Withdraw the fan gently taking care not to damage rubber gasket. Slacken the impeller retaining grub screw and remove the impeller from the motor shaft. Undo the four nuts exposed by the impeller removal and take off the motor mounting plate. This together with the impeller can now be fitted to the new motor. Position the impeller to give a 6 mm clearance between motor plate and impeller back-plate. Reverse the remainder of the procedure for re-assembly. Replace any cable ties removed, securing the motor wires to the loom. Start the boiler and check that the CO₂ percentage at the sampling point (see Fig. 5) is 0 - 10%.

14.5 MAIN SOLENOID VALVE COIL ASSEMBLY RENEWAL (Johnson Maclaren - alternatively Teknigas)

See parts list - Page 29.

It is likely that the main cause of gas valve failure will be due to coil winding failure, either open or short circuit. If this is the case, it is possible to replace the coil assemblies only.



HAMWORTHY heating products

1) Johnson Coil Assembly (Hamworthy Part No. 533903006)

Disconnect wires from coils. Remove the coil earth leads (green/yellow) from the earthing post on the valve coil body. Remove the nuts securing solenoid coils on the gas valve and withdraw. Fit new coil assembly onto the gas valve, refit nuts. Connect coil leads and re-make the solenoid earth connection.

2) Teknigas Coil Assembly (Hamworthy Part No. 363417926)

Disconnect coil wires from the 6 way terminal block at main cable entry position; brown crimped leads from Terminal 2 and blue crimped leads from Terminal 3. Remove the coil earth leads (green/yellow) from the earthing post on the burner control bracket, and withdraw from cable grommet in the control bracket. Remove the circlips securing solenoid coils on the gas valve and withdraw. Fit new coil assembly onto the gas valve, refit circlips. Feed coil leads through the rubber grommet in the control bracket. Wire brown crimped leads to Terminal 2 and blue crimped leads to Terminal 3 in incoming mains terminal (6 way). Re-make the solenoid earth connection to the boiler earthing post.

On completion of either 1) or 2) start the boiler and check the burner pressure across test points A and B (see Fig. 6) and adjust the gas pressure governor as necessary. After approximately 15 minutes firing, check the gas rate with a meter and watch, if necessary, and make final adjustments.

Start the boiler several times to check the new coils for reliability.

14.6 PILOT SOLENOID VALVE COIL RENEWAL (Hamworthy Part No. 74744549)

Release the screw that retains 'DIN' plug to the solenoid coil and pull clear of valve. Remove red cap from coil top and pull off coil. Re-fit new coil, replace red cap and engage 'DIN' plug, ensuring securing screw is tightened. Start the boiler several times to check the new coil for reliability.

14.7 AIR PRESSURE SWITCH RENEWAL (Hamworthy Part No. 747146295)

Remove cover plate by releasing posihead screw. Disconnect and remove wires from terminals. Release bundy tube nuts at switch. Remove fittings and refit to new switch.

NOTE: When fittings are removed from switch ensure that holes are clear of any obstruction and jointing compound before re-fitting to new switch.

Re-fit new switch and connect wiring as indicated:

- a) White/Red wire to terminal marked "N.O."
- b) White wire to terminal marked "C"
- c) Green/Yellow wire to earthing point on body.

Replace cover plate. (This switch will have been FACTORY SET.)

Start the boiler several times to check for reliability.

14.8 CONTROL THERMOSTAT RENEWAL (See Appendix) (Hamworthy Part No. 339009345)

Alternative thermostat manufacturers may be used in the Wessex boiler controls assembly. However, the fitting and wire spade connections are physically identical. The terminal identification may well be different from that shown on the wiring diagram. Please refer to fixing instructions included with the thermostat to ensure correct connections are made and correct operation is obtained.

To replace the thermostat the following procedure must be followed. **NOTE!** Record existing temperature setting of thermostat for reference before removal.

Remove thermostat capillary retaining clip at pocket and withdraw the bulb from the pocket in the flow header. Remove the spaded yellow and pink leads at the "push-on" terminal on the thermostat body. Pull off the control knob and remove the spring and silver bezel. The thermostat is retained to the support bracket by two M3 screws, one of which is a pillar type and forms the control knob stop. Take care to note the relative position of the two screws before removing them (i.e. the lower screw has a pillar head), together with the thermostat body.

Re-assemble the new thermostat in reverse procedure ensuring the YELLOW and PINK leads connect the thermostat in the normally closed position. (Identified as contacts 1 and 2 on the thermostat body.) Run the boiler and turn the thermostat up and down to check for correct operation during the warm up period.

NOTE: For adjustment of thermostat operating range refer to Section 11.7. See Note to 1,0 Introduction.

14.9 TEMPERATURE LIMITER (See Appendix 1) (Limit Thermostat) (Hamworthy Part No. 339011044)

Remove thermostat capillary retaining clip at pocket and withdraw the bulb from the pocket in the flow header. Remove the spaded PINK and ORANGE/BLACK leads at the "push-on" terminals on the thermostat body. Undo the



HAMWORTHY heating products

bulkhead nut and withdraw the thermostat.

Fit the new temperature limiter (limit thermostat) in reverse procedure ensuring that the PINK and ORANGE/BLACK leads connect the thermostat in the normally closed position. (Identified as contacts 1 and 2 on the device body).

To check it's operation, link out the control thermostat and run the boiler whilst gradually reducing the water flow through the boiler until it shuts down. Check the boiler thermometer during this operation to ensure that the temperature limiter is working correctly. Re-establish the waterflow. When the water temperature has cooled down the boiler should remain off until the green reset button on the thermostat is pressed. Remove the link across the control thermostat.

14.10 SEQUENCE CONTROLLER RENEWAL (Hamworthy Part No. 747246236)

Release the screw retaining the sequence controller and pull the top clear of the base-plate to expose the terminal rails. Re-fit the new controller top onto the existing base plate and tighten the retaining screw.

To check the correct operation of the new controller, commission the appliance according to the notes detailed in Section 11.4.

14.11 IGNITION TRANSFORMER RENEWAL (Hamworthy Part No. 747217120)

Release the screw retaining the sequence controller and pull the top clear of the base-plate to expose the terminal rails. Pull off H.T. cap from ignition electrode and unscrew cap from lead. Disconnect wiring from base-plate at terminals A, 8 and E. Release two screws securing base-plate and transformer to control brackets, remove transformer.

Re-assemble components in reverse order making sure that the transformer is earthed at the earthing terminal. Start the boiler several times to check for reliability.

14.12 NEONS AND ON/OFF SWITCH RENEWAL

GREEN NEON - Hamworthy Part No. 747436456
RED NEON - Hamworthy Part No. 747436449
ON/OFF SWITCH Hamworthy Pt. No. 339006648

Pull off electrical leads to the appropriate item. Release switch or lamp from mounting fascia by pressing in the plastic retaining lugs at the top and bottom.

Pull switch or lamp out frontwards. Push in new item until lug locks in position and reconnect leads. Start the boiler several times to check reliability.



HAMWORTHY
heating products

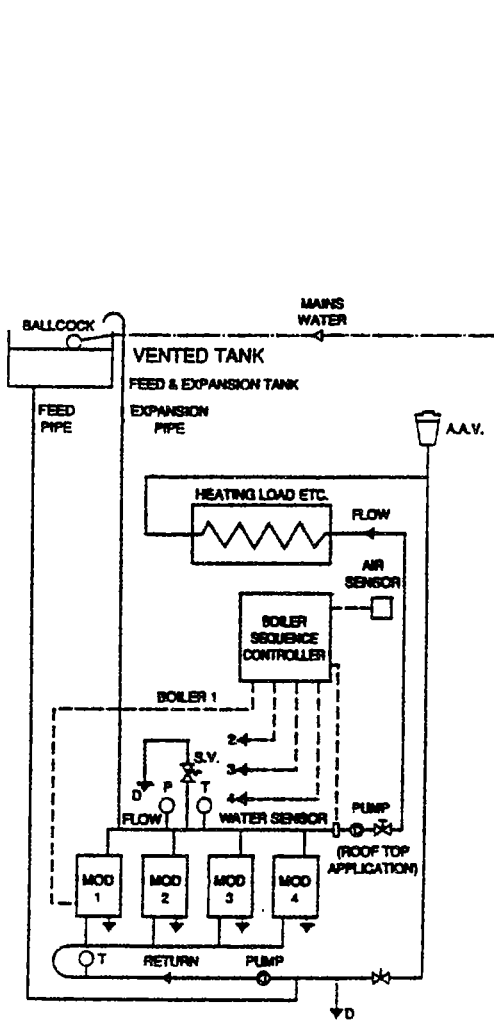

VENTED SYSTEM

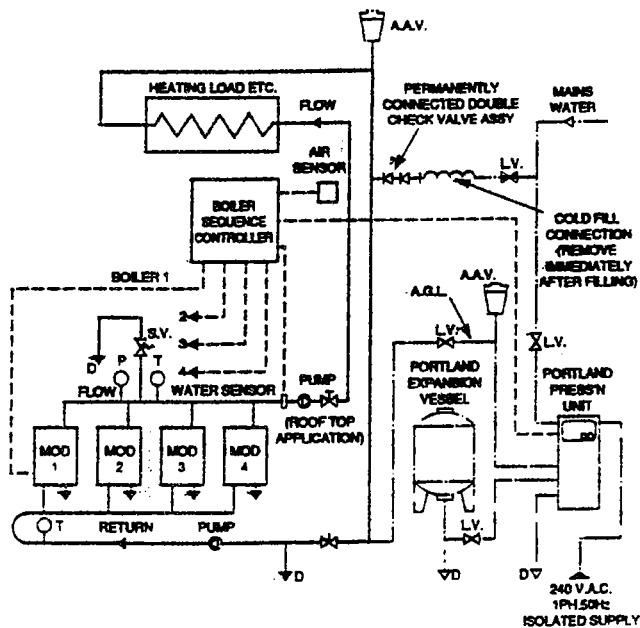

UNVENTED SYSTEM

Boiler Installation (Typical)
Vented and Un Vented Systems

T - Thermometer D - Drain
P - Pressure Gauge AAV - Air Separator/Auto-Air Vent
LV - Lockshield Valve AGL - Anti-Gravity Loop
SV - Safety Valve



HAMWORTHY
heating products

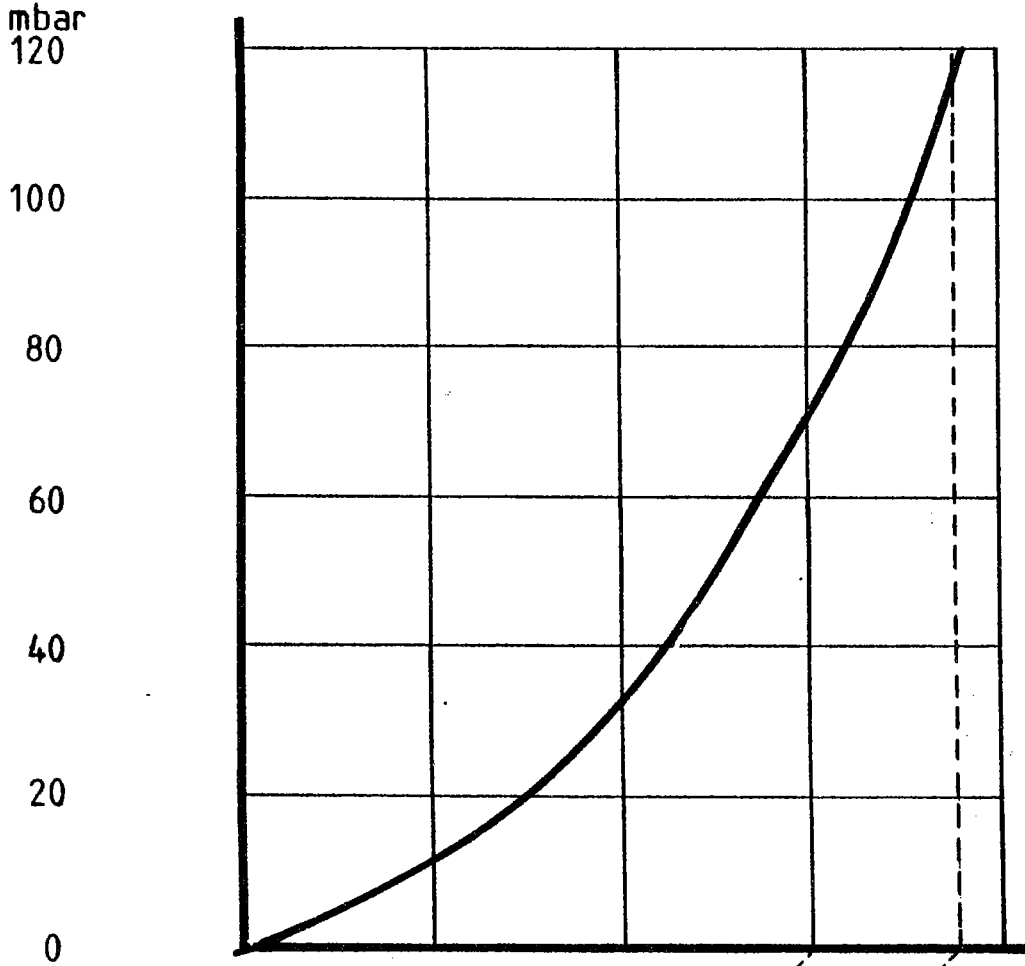

MINIMUM FLOW 3000 l/h per MODULE

DESIGN FLOW RATE 3800 l/h per MODULE

WESSEX 1x50

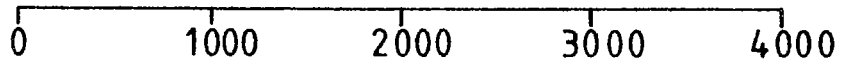

WESSEX 2x50

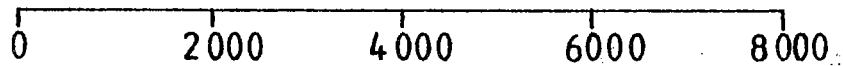

WESSEX 3x50

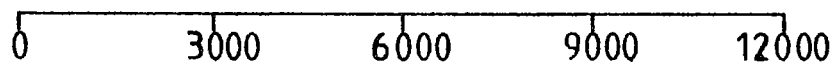

litres / hour

Fig. 2. Water Pressure Drops

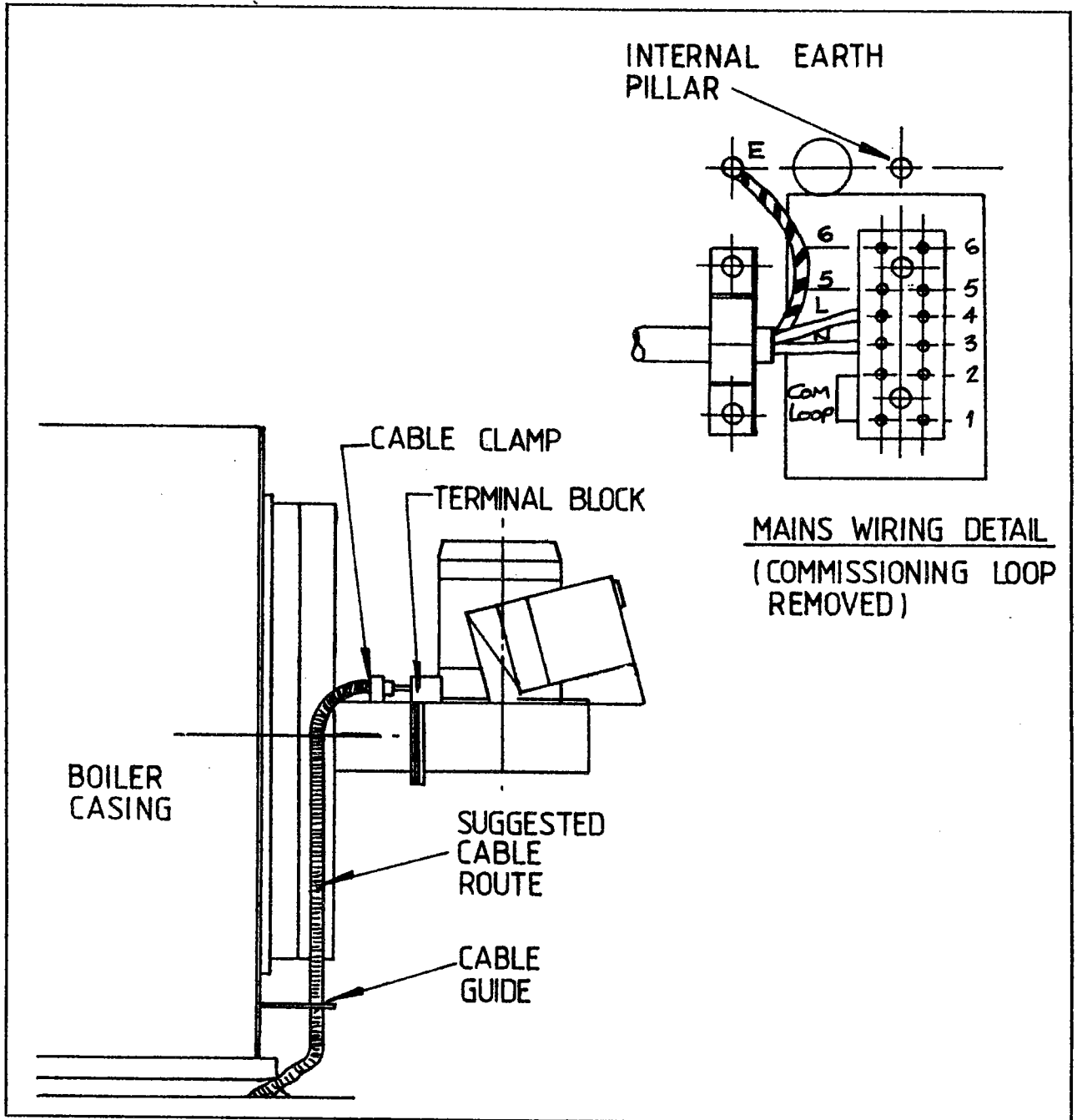

Fig. 3 Mains Cable Route

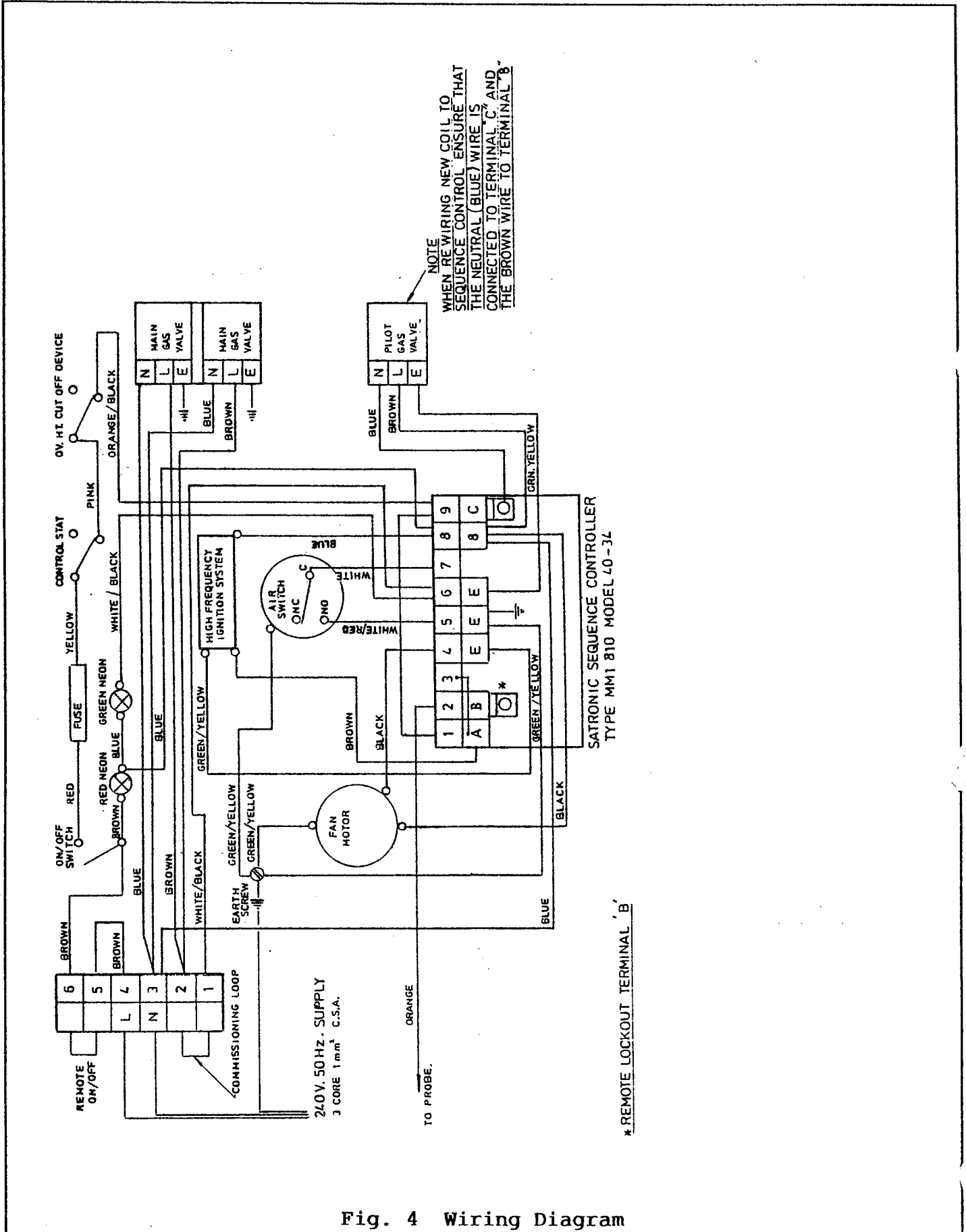

Fig. 4 Wiring Diagram



HAMWORTHY
heating products

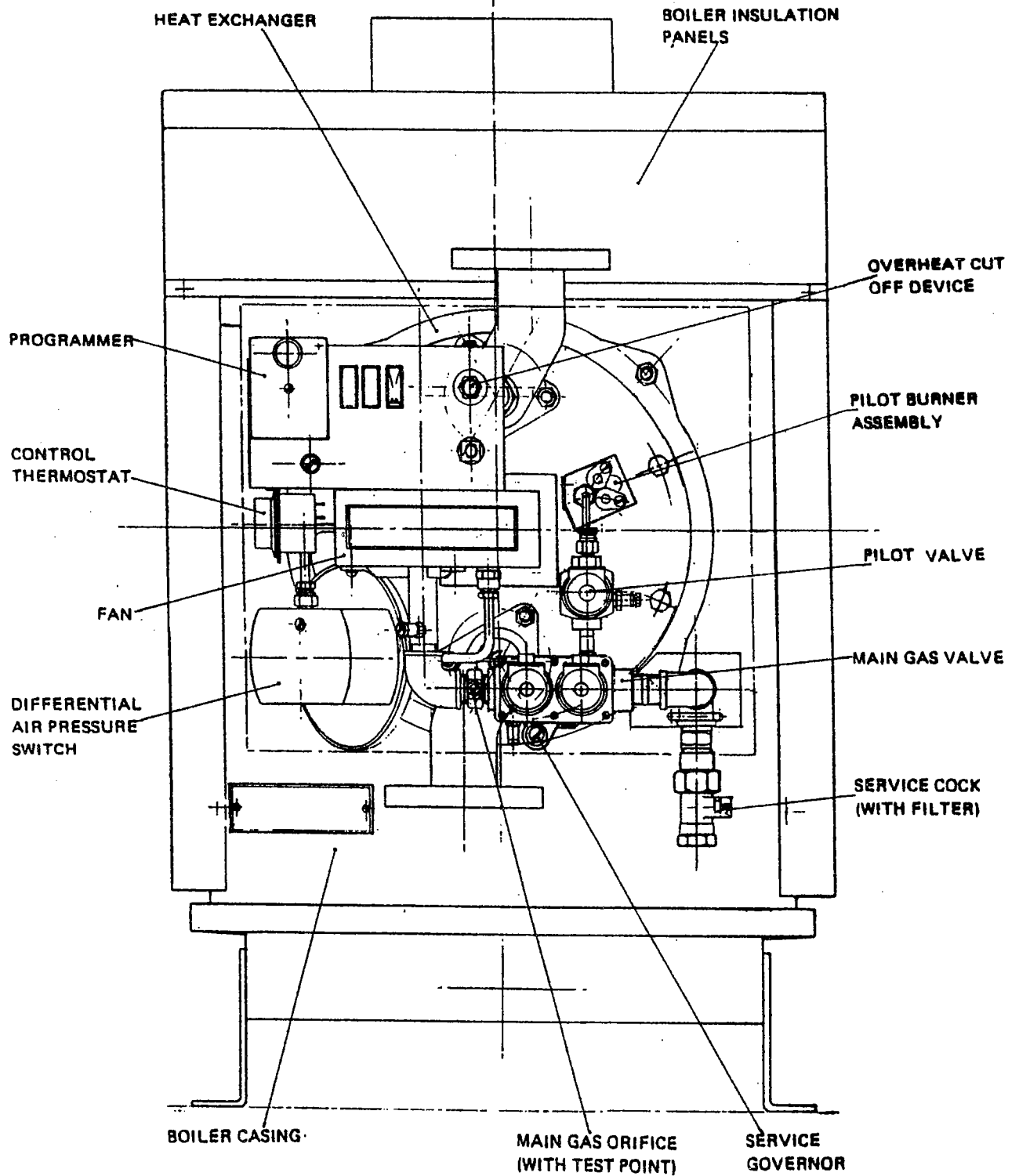
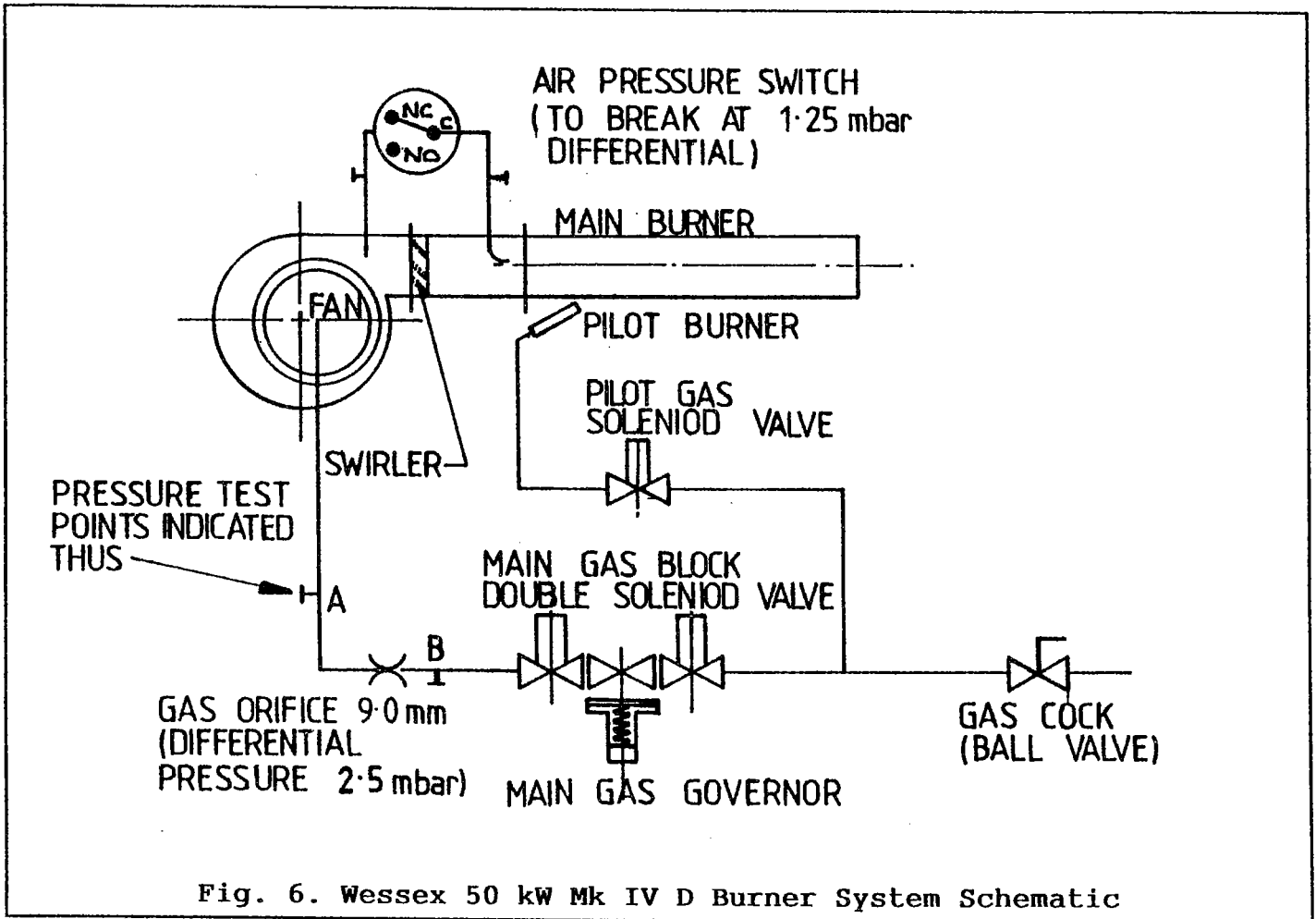

Fig. 5. Wessex 50 kW Mk IV D Boiler Front Arrangement





HAMWORTHY
heating products

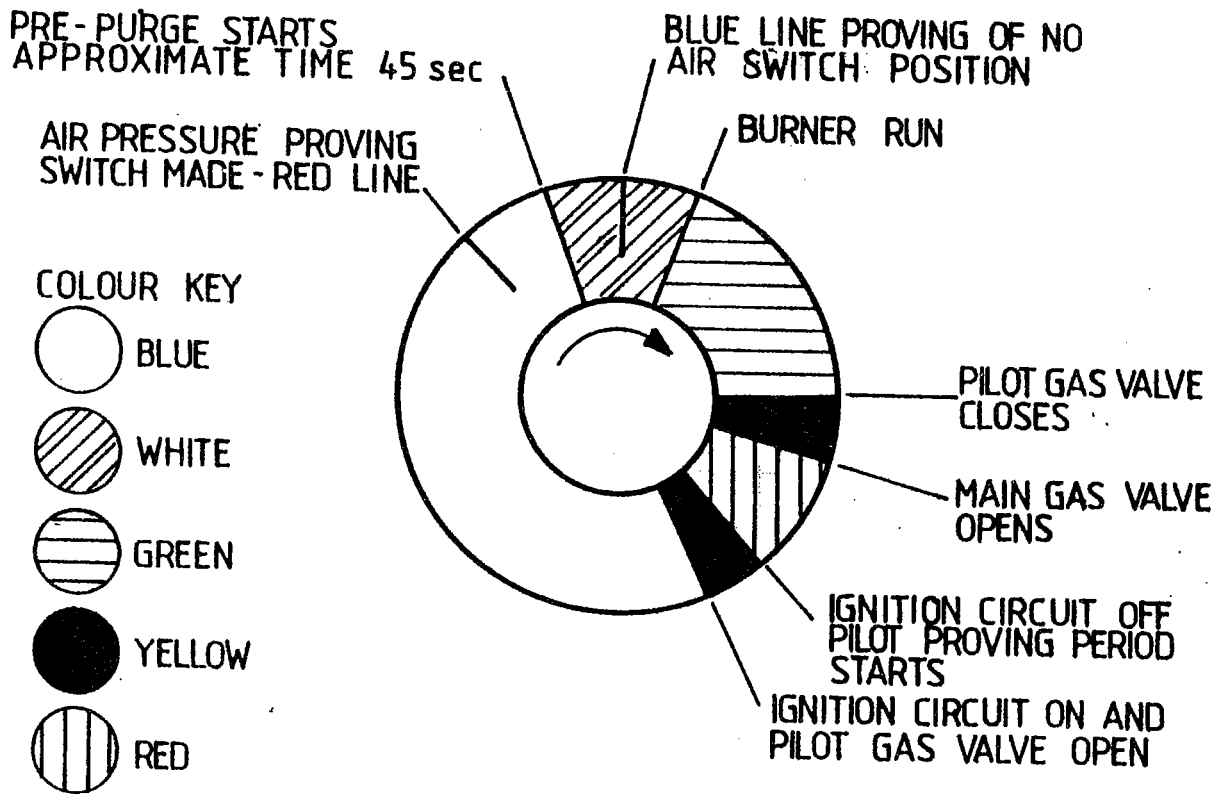

Fig. 7 Sequence Controller Programme Indicator Coloured Disc
WESSEX 50 KW BOILER 23 500001007 ISSUE 'C'



HAMWORTHY
heating products

WESSEX MK IV 1 x 50.

WEIGHT EMPTY 85 Kg.
FULL 90 Kg.

WESSEX MK IV 2 x 50.

WEIGHT EMPTY 165 Kg.
FULL 175 Kg.

WESSEX MK IV 3 x 50.

WEIGHT EMPTY 249 Kg.
FULL 255 Kg.

NOTE: ALL FLANGES TO B.S. 4504 TABLE G/3. WATER FLOW OR RETURN FLANGE POSITIONS MAY BE FITTED OPPOSITE HAND IF REQUIRED. ALL DIMENSIONS IN MILLIMETRES. DIMENSIONS SHOWN INCLUDE 30 MM THICK EXTERNAL INSULATED CASING PANELS.

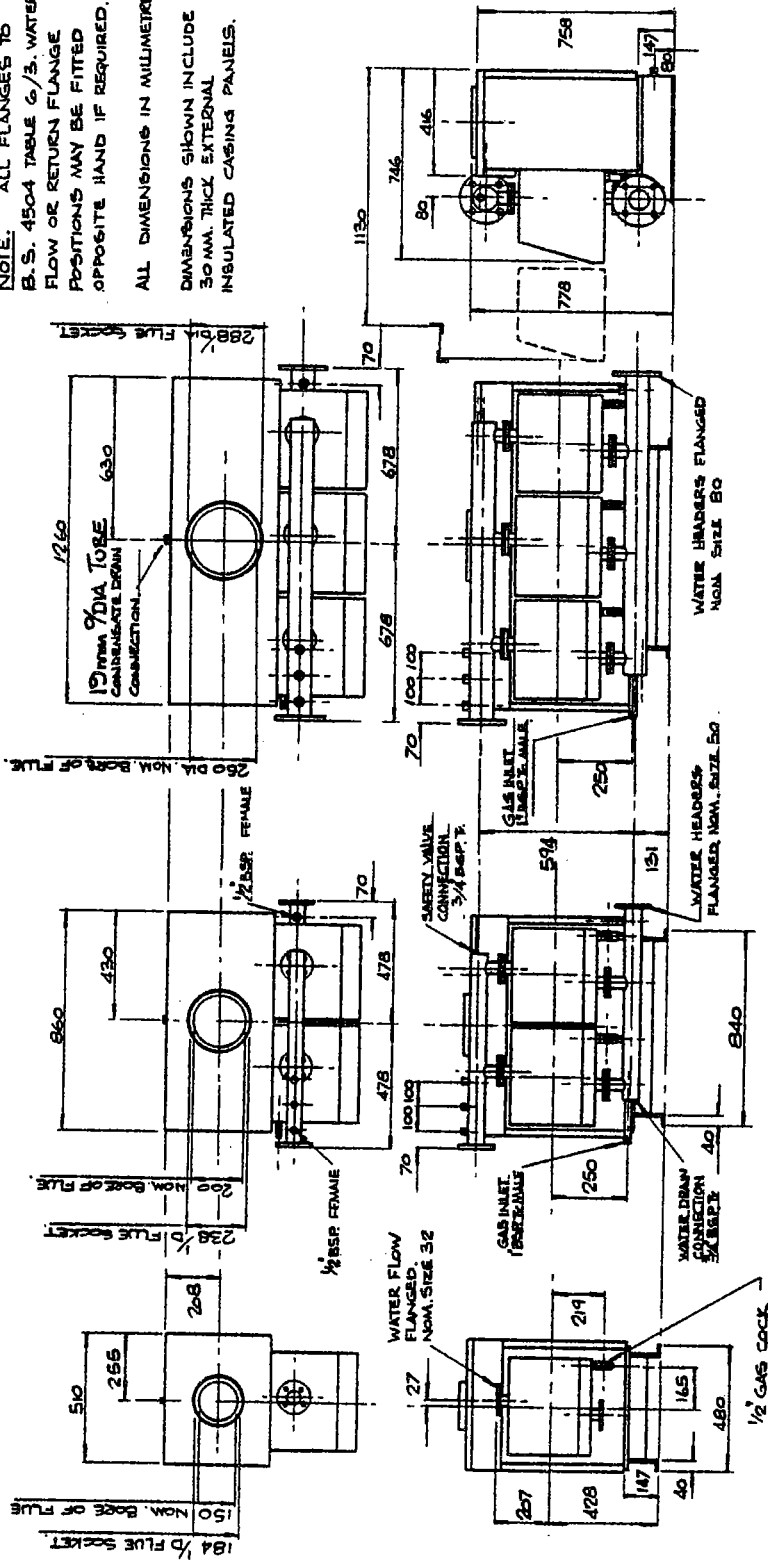

Fig 8 Arrangement Drawing, Wessex 1 x 50, 2 x 50 and 3 x 50
WESSEX 50 KW BOILER



HAMWORTHY
heating products

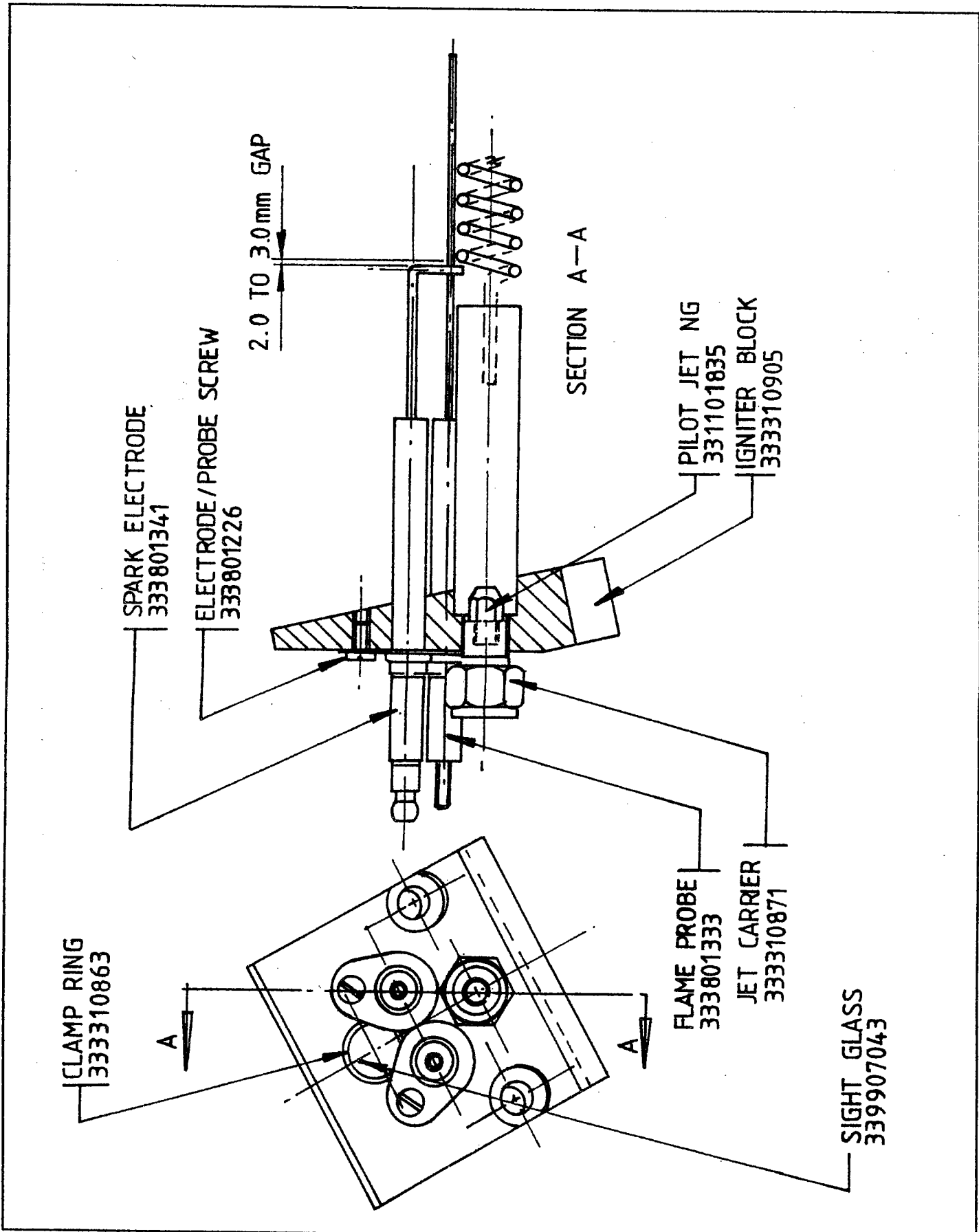

Fig 9 Wessex 50 kW Mk IV Pilot Burner Assembly (363310387)
WESSEX 50 KW BOILER 25 500001007 ISSUE 'C'



HAMWORTHY
heating products

TO CHECK B.C.D.

- 1) Turn off the electrical power to the appliance.
- 2) Connect the manometer assembly to TP1 and TP2 (see Fig 1a).
- 3) With A, B, C, E closed, open F and "Crack Open" D to produce 2" WG on manometer. (5 mbar).
- 4) Close D and monitor no rise on manometer over a 2 minute period* - a rise would indicate a leak on valve D.
- 5) Repeat at 8" WG between B, C, D.
- 8) Close D and F.
- 9) Drop pressure between B, D, C by removing connection to TP2.
- 10) System A, B may be considered sound if over a period of 2 minutes* any pressure drop is less than 0.2" WG (0.5 mbar).

* NOTE: Allow a manometer stabilisation period of approximately 1 minute before each 2 minute check period.

System B, C, D may be considered sound if over a period of 2 minutes any pressure drop is less than 0.2 WG (0.5 mb).

Following soundness tests, remove manometer connections and tighten test points TP1 and TP2.

TO CHECK A.B.

- 6) Open E and F.
- 7) Crack D to produce 8" WG between A, B.

NOTE: Care must be taken not to allow soapy water on or near any electrical parts or connections.

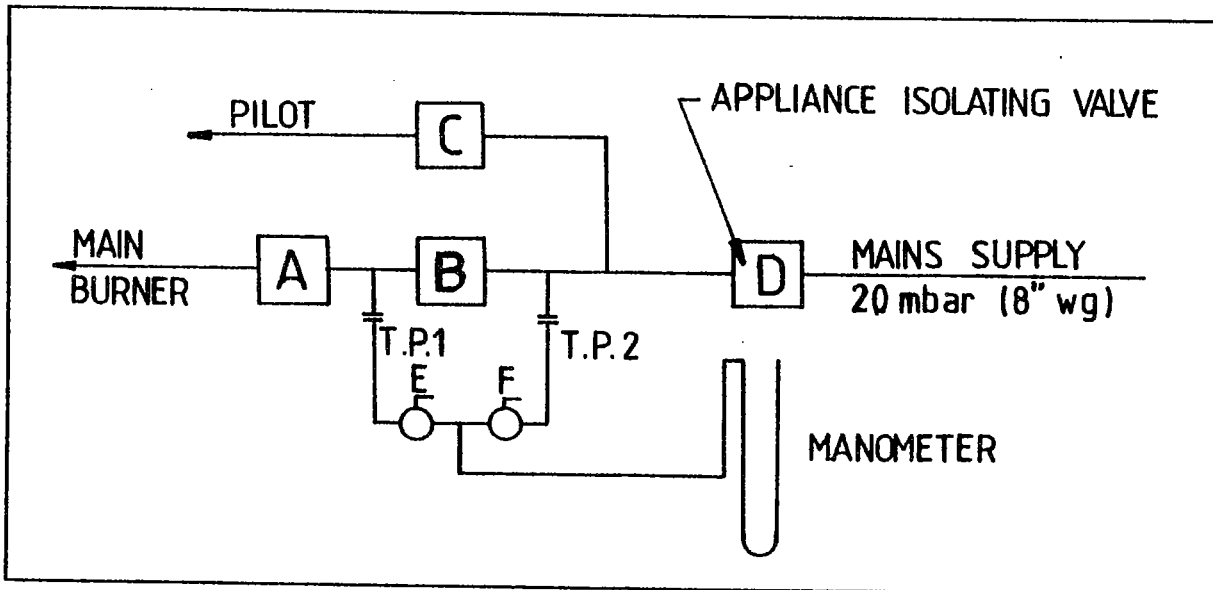

**Fig. 10. Wessex Boilers - 50 kW and 200 kW Models
Valve and Pipework Soundness Testing**



HAMWORTHY
heating products

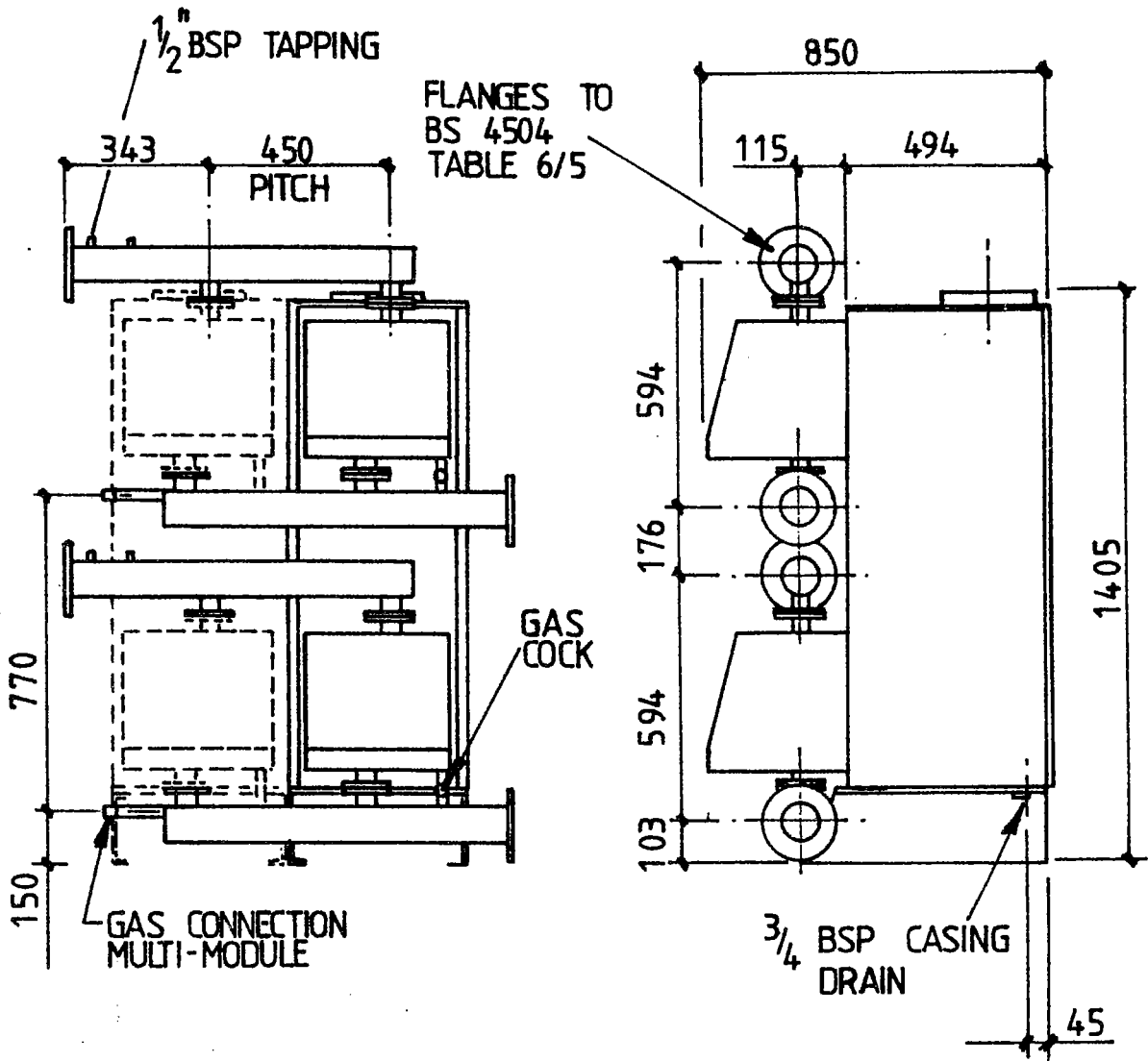

NOTE 1x100 REQUIRES NO MANIFOLD HEADERS

MODULE BANK SIZE	1x100	2x100	3x100	4x100	5x100	6x100
WATER HEADER (NB)	32	50	80	80	80	80
GAS HEADER (NB)	15	25	32	32	32	32

Fig 11 Arrangement Drawing Wessex 100 Compact
WESSEX 50 KW BOILER 27 500001007 ISSUE 'C'

Appendix 1. Control Thermostat Setting Procedure

See Note to 1.0 Introduction

Landis & Gyr Thermostat

Adjusting the limitation of angle of rotation only for thermostats with drum type setting knobs.

1. Pull the setting knob off the thermostat spindle.
2. Remove the spring clip and limit stop discs (1) and (2) from inside the setting knob.
3. Insert limit stop disc (1) into the setting knob so that its stop arm locks onto that rib having the guide number (5) which corresponds to the start value of the desired setting range.
4. Insert limit stop disc (2) in the same manner, but this time choosing the rib and guide number which corresponds to the end value of the desired setting range.
5. Replace spring clip, thus securing the limit stop discs.
6. Push the setting knob back on to the thermostat spindle so that the stop screw is located within the selected setting range.
7. Rotate the setting knob to the limit stops of both ends of the scale to check the adjusted range against the setting scale.
 - A. Desired start value of the new setting range in °C. Corresponding guide number for limit stop disc (1).
 - B. Desired end value of the new setting range in °C. Corresponding guide number for limit stop disc (2).

Setting Range °C	Limit Stop Disc Nr		1	3	5	7	9	11	13	15	17	19	21	23	25	27
			50-110	1	A	50	55	60	65	70	75	80	85	90	95	100
2	B	-		50	55	60	65	70	75	80	85	90	95	100	105	110

IMIT Thermostat

- 1) Pull the setting knob off of the thermostat spindle.
- 2) Reposition the spring stop inside the control knob to new setting.
- 3) Push the control knob back on the spindle and rotate to ensure the settings provide the correct desired setting range.



HAMWORTHY
heating products

HAMWORTHY HEATING LIMITED - SPARES DEPARTMENT

FLEETS CORNER POOLE DORSET BH17 7LA TEL: 0202 665566

RECOMMENDED SPARES FOR WESSEX 50 KW MK IV D

QUANTITY	DESCRIPTION	PART NO.
1	Spark Electrode	333801341
1	Flame Probe	333801333
1	Sight Glass	339907043
1	Fan (Motor only)	339011085
1	Fan (Motor Assembly)	339011069
1	Johnson Main Solenoid Valve Assembly	533903005
1	Johnson Main Solenoid Coil Assembly	533903006
1	Teknigas Main Solenoid Valve Assembly	363916571
1	Teknigas Main Solenoid Coil Assembly	363417926
1	Pilot Solenoid Valve	747442520
1	Air Pressure Switch	747146295
1	Control Thermostat	339009345
1	Overheat Cut Off (Limit Stat)	339011044
1	Sequence Controller	747246236
1	Ignition Transformer	747217120
1	Green Neon	747436456
1	Red Neon	747436449
1	On/Off Switch	339006648
1	Pilot Burner Assembly (Igniter)	363310387
1	Burner Assembly	363309025

Customer Services

CUSTOMER SERVICES

APPLICATION

To supplement the detailed Technical Information Booklets, technical advice on the application and use of the Hamworthy Heating Product Range is available from Poole and through the regional Sales offices and Accredited Agents.

COMMISSIONING

A commissioning service is offered for all the Hamworthy Heating Products. Commissioning by the manufacturer ensures the most efficient performance is achieved safely and ensures correct operation.

Hamworthy commissioning reports are detailed and definitive. Such information reports on the original status of the plant are essential for future routine maintenance and fault finding situations.

ROUTINE SERVICE

Hamworthy offer routine service contracts for all products. Planned maintenance of equipment by routine servicing reduces operational costs considerably below that associated with repair or breakdown approach. Regular servicing by Hamworthy trained staff ensures that all equipment is operating to optimum efficiency.

The frequency of visits to maintain installations up

to required level is variable depending upon the equipment type and usage.

BREAKDOWN SERVICE, REPAIR, REPLACEMENT

Even when the commissioning and routine servicing has been carried out to the highest standard there are always occasions when the unexpected breakdowns occurs. Hamworthy provide a rapid response breakdown, repair or replacement service through its regional offices and Accredited Agents located throughout the UK.

SPARE PARTS

A comprehensive spare parts service is operated from our head office at Poole providing delivery, even for out of date items in most cases. In some instances spares may be available from regional offices and Accredited Agents.

Delivery of parts and components is normally from stock within 7 days. However, a 24 hour service is available for breakdowns and emergencies for the additional cost of the courier.

For your spares enquiries and orders please contact Carol Miller on 01202 665566.

To help Carol and her staff help you, please give as much detail as possible of the product type, serial number or any other identifying marks or codes.

**HEAD OFFICE (DEPOT & WORKS)
HAMWORTHY HEATING LIMITED
FLEETS CORNER,
POOLE, DORSET BH17 0HH
TEL: 01202 665566
FAX: 01202 665111**

OFFICES:

**MIDLANDS
HAMWORTHY HEATING LIMITED
Shady Lane,
Great Barr,
Birmingham B44 9EX
Tel: 0121 360 7000
Fax: 0121 325 0890**

**ACCREDITED AGENTS:
BERKS, BUCKS, OXON,
SURREY & WEST LONDON
FOWLER COMBUSTION CO. LIMITED
18 Oxford Road,
Wokingham,
Berks RG11 2XY
Tel: 01734 784350 Fax: 01734 771497**

**SOUTH (CENTRAL)
DRIVER ENGINEERING LIMITED
778 Wimborne Road,
Moordown,
Bournemouth BH9 2DX
Tel: 01202 525140 Fax: 01202 536442**

**NORTH WEST (PART)
GILLIES MODULAR SERVICES
210-218 New Chester Road,
Birkenhead,
Merseyside L41 9BG
Tel: 0151 666 1030**

**NORTH EAST (PART)
ALLISON HEATING PRODUCTS
17 Beach Road,
South Shields,
Tyne & Wear NE33 2QH,
Tel: 0191 455 7898 Fax: 0191 455 7899**

**SCOTLAND
McDOWALL MODULAR SERVICES
97a Hawthorn Street,
Glasgow G22 6JD
Tel: 0141 336 8795 Fax: 0141 336 8954**

**NORTHERN IRELAND
McCAIG COLLIM LIMITED
94 Dargan Crescent,
Duncrue Industrial Estate,
Belfast BT3 9JP
Tel: 01232 777788**

**HAMWORTHY
Heating Products**

Offices and Agents throughout the world