

Heating with wood chips & pellets



firematic

20 - 60 kW



firematic

80 - 499 kW



Competence is our success...

HERZ FACTS:

- 22 companies
- Group headquarters in Austria
- Research & development in Austria
- Austrian owned
- 1,600 employees in more than 75 countries
- 11 production sites



HERZ – The company

Founded in 1896, Herz has been continuously active in the market for more than 117 years. With 6 sites within Austria, another 5 in Europe and more than 1,600 employees at home and abroad, HERZ is the only Austrian manufacturer that produces equipment for the entire heating and installation industry and is one of the most important internationally.



HERZ Energietechnik GmbH

HERZ Energietechnik employs more than 200 staff in production and sales. At the company sites in Pinkafeld, Burgenland and Sebersdorf, Styria, there is state-of-the-art production as well as a research institute for new, innovative products. For a number of years, HERZ has worked with local research and training institutes. Over the years, HERZ has established itself as a specialist in renewable energy systems. HERZ places a great importance on modern, cost-effective and environmentally friendly heating systems with the highest level of convenience and user-friendliness.

HERZ for the environment

All HERZ furnace systems fall below the strictest emission regulations. Numerous environmental endorsements bear witness to this.

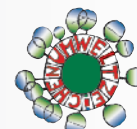

HERZ quality

HERZ designers are in constant contact with recognised research institutes in order to improve the very high standards even further.



Convenient heating...

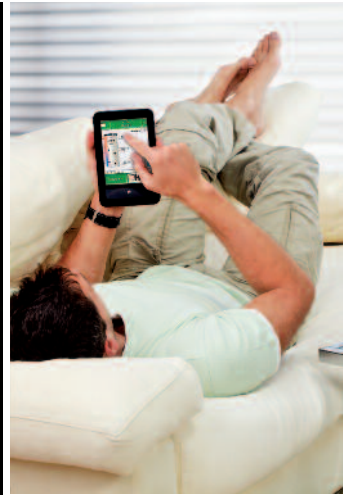

Decades of experience

- In-house development and test centre
- Austrian quality with europe-wide sales
- Comprehensive service
- ISO 9001 certification

Economical and convenient heating using wood chips.

The cleanest combustion thanks to Lambda probe control even with variable fuel quality.

The quiet operation of the boiler is thanks to its high-quality system components.

The lowest emission values to protect our environment.

The great advantages of HERZ firematic:

- Energy-saving drive technology
- Simple operation
- Consistently high efficiency factor
- Compact design
- Constructed from high quality materials

Automatic cleaning ...

- ... of the combustion grate
- ... of the vertical pipe heat exchanger
- Automatic de-ashing of the combustion and fly ash in to an easily accessible ash bin

Easy, modern and comfortable...

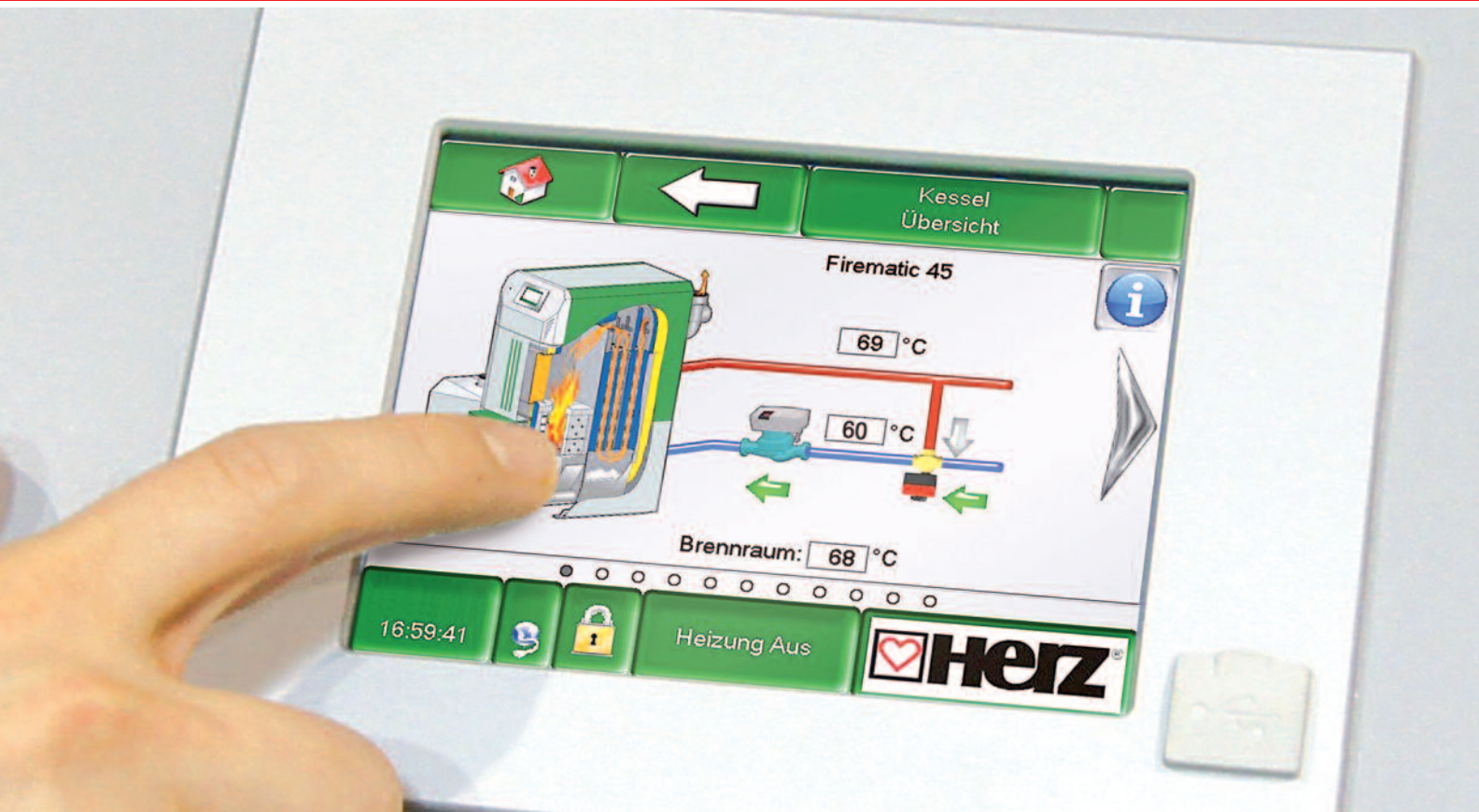

With the user-friendly VGA color touch-screen controller, the burning-process, as well as heating circuits, a hot water tank, buffer tank and a solar system can be controlled.

T-CONTROL

A central controller for:

- Buffer management
- Return flow temperature bypass (pump and mixer valve)
- Domestic hot water preparation
- controlled heating circuits (pump and mixer valve)
- solar circuit control
- frost protection

The convenient menu and simple screen layout with schematic 3D-representation ensures maximum user-friendliness.

The “modular operation” of the T-CONTROL offers extension possibilities up to 55 modules. This allows the central control unit to process the combustion (with lambda sensor), buffer management, return temperature rise, heating circuits, hot water preparation, solar circuit and more optimal together. Additionally, the control system can be easily expanded or modified with the external modules.

... with the central control unit T-CONTROL



T-CONTROL

Remote access to the controller using VNC Viewer

As an additional option, the T-CONTROL offers the possibility for remote visualization and remote maintenance via smartphone, PC or tablet PC. The handling is the same as in the touch controller directly in the boiler. The processes and parameters can be read and modified any time from anywhere.

Further advantages of the T-CONTROL:

- power-saving standby mode
- status and error messages via e-mail
- Data transfer and software updates via USB stick
- Possibility of Modbus-Communication
- easy and clear presentation of the functions from various components (hot water preparation pump, circulation pump, mixing valve, switchin valve, actuator-motors usw.)

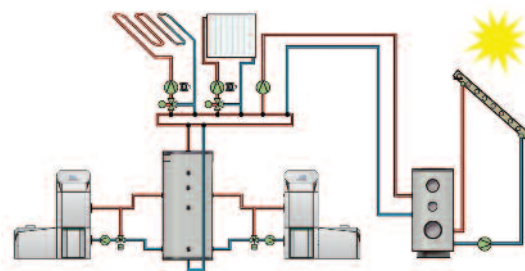

Cascade switching

Using the HERZ T-CONTROL, up to 8 HERZ boilers equipped with T-CONTROL can be switched to cascade (CAN BUS). Cascade switching offers superior load profile matching, higher efficiency, and ensures even distribution of wear by automatically switching the lead role.

Benefits and details...

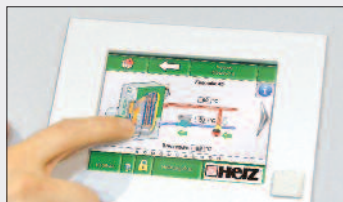

The HERZ T-CONTROL with touch display

Central control unit as standard for:

- Buffer management
 - Return flow temperature bypass (pump and mixer valve)
 - domestic hot water preparation
 - controlled heating circuit (pump and mixer valve)
 - frost protection
- Simple screen design and convenient menu guide.
 - Extension modules up to 55 modules possible (heating circuits, solar-use, second buffer etc.)

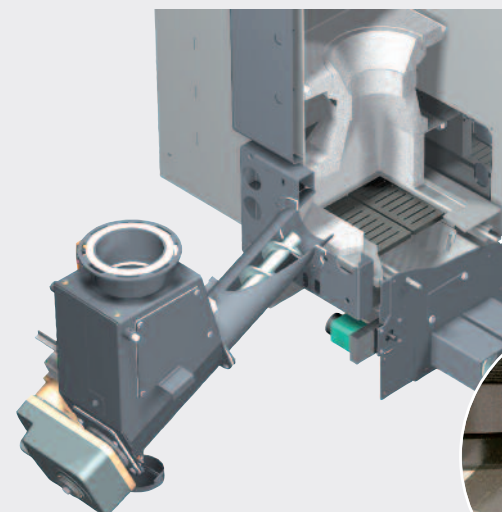

Side load & automatic cleaning of the combustion grate

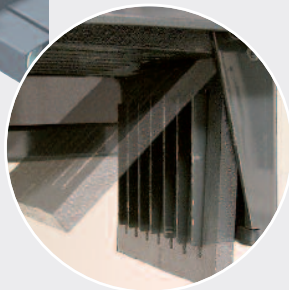

- Side load of woodchips or pellets into the combustion chamber
- Complete cleaning of combustion grate which automatically tips ash to extraction point.
- A clean combustion grate guarantees an optimum air supply.
- Minimises the manual cleaning requirement.



Automatic de-ashing

- Via the two ash discharge screws the combustion and fly ash is automatically augered into the ash bin.
- The removable ash bin with wheels enables simple and convenient emptying of the ash.

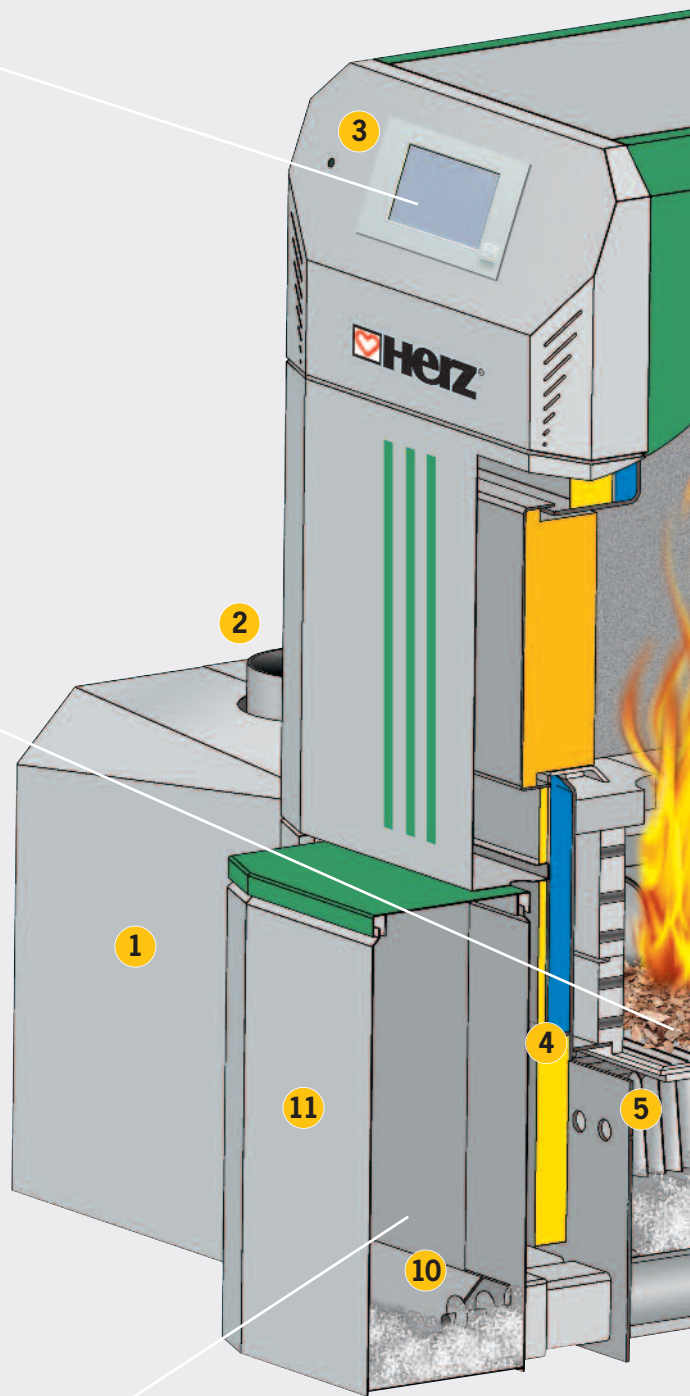

1. **Intermediate container** with infrared light barrier system (removes the need for mechanical level control)
2. **BBP** (back burn protection device; flap) **BBI** (back burn inhibit device; sprinkler system)
3. **T-CONTROL** central control unit

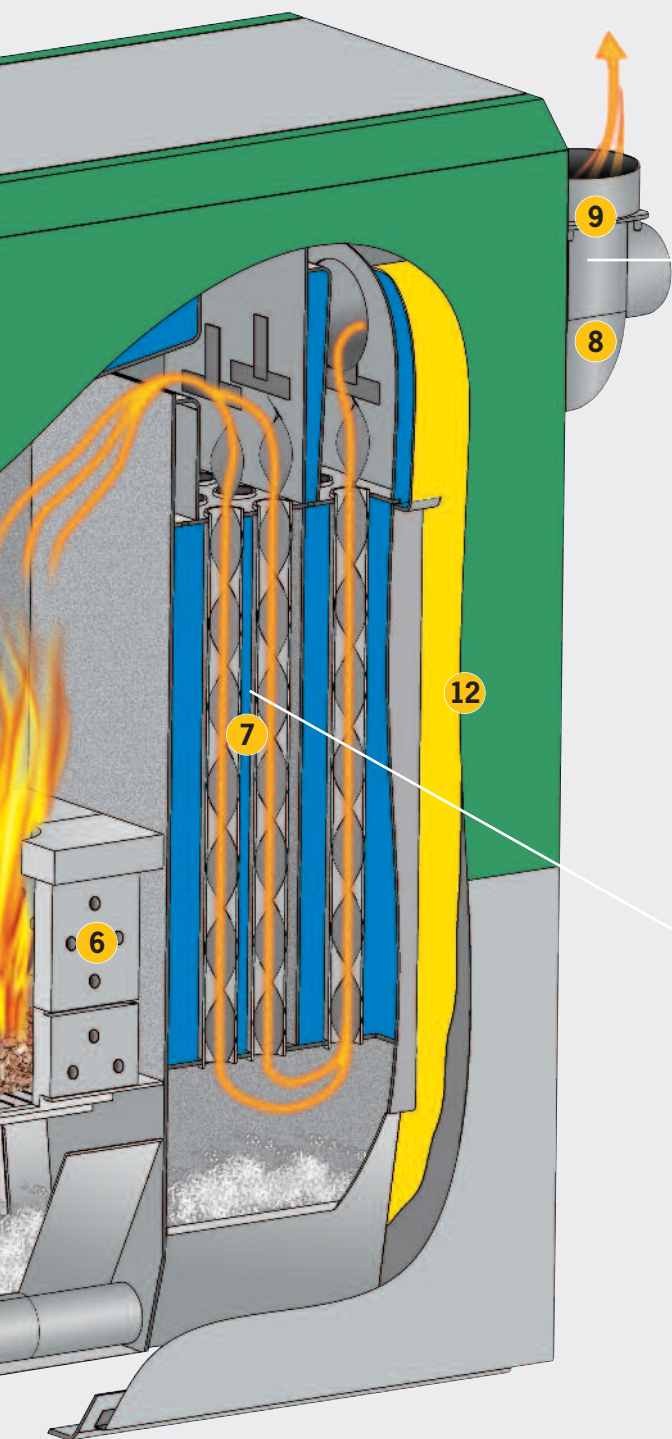

Energy saving combustion via the Lambda probe



- Thanks to the in-built Lambda probe, which continuously monitors the flue gas values, the boiler reacts to changes in fuel quality ensuring optimum combustion and extremely low emission values.
- The Lambda probe controls the primary and secondary air supply ensuring complete combustion, even in partial load operation.
- The results are low fuel consumption and the lowest emission values even with different fuel qualities.

Automatic cleaning of the heat exchanger



- The heat exchanger surfaces are automatically cleaned via the integrated turbulators, even during heating operation, eliminating manual cleaning.
- A consistently high level of efficiency thanks to cleaned heat exchanger surfaces enables low fuel consumption.
- Falling ash is taken into the ash bin via an auger.

4. Automatic ignition
using hot air fans

5. Tipping grate for complete cleaning

6. Split 2-zone combustion chamber

7. Pipe heat exchanger
with turbulators and automatic cleaning

8. Lambda probe control
Automatic flue and combustion monitoring

9. Draft fan
speed controlled and monitored for the highest operating safety

10. Ash discharge screw
for combustion and fly ash

11. Front ash box

12. Efficient heat insulation
for the lowest radiated heat loss

Benefits and details...



The HERZ T-CONTROL with touch display

Central control unit as standard for:

- Buffer management
 - Return flow temperature bypass (pump and mixer valve)
 - domestic hot water preparation
 - controlled heating circuit (pump and mixer valve)
 - frost protection
- Simple screen design and convenient menu guide.
 - Extension modules up to 55 modules possible (heating circuits, solar-use, second buffer etc.)

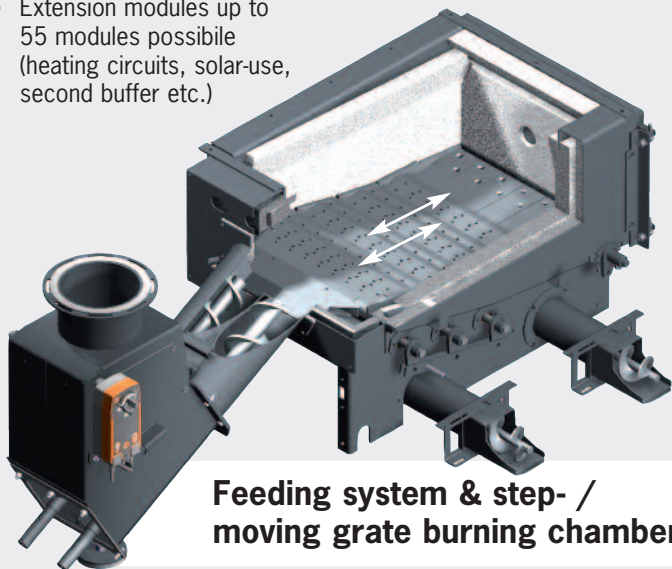

Feeding system & step- / moving grate burning chamber

- Woodchips or pellets are transported from the side into the combustion chamber (with single stoker screw for firematic 20-101 and double stoker screw for firematic 130-499).
- The movement of the step grate is also a cleaning mechanism of the burning chamber. These grate elements consist of special, high-quality cast iron. Through the movement of the step-/moving grid the biomass is transported through the combustion area. The burning chamber is split into primary and secondary air zones. The movement guarantees optimal air flow through the cleaned grate.
- The cleaning of the combustion chamber from burning ash is carried by an automatically tipping grid. The screw below transports the ash directly into the ash bin.
- No manual effort required.



Automatic de-ashing

- Via the two ash discharge screws the combustion and fly ash is automatically augered into the ash bins.
- The removable ash bins with wheels enables simple and convenient emptying of the ash.

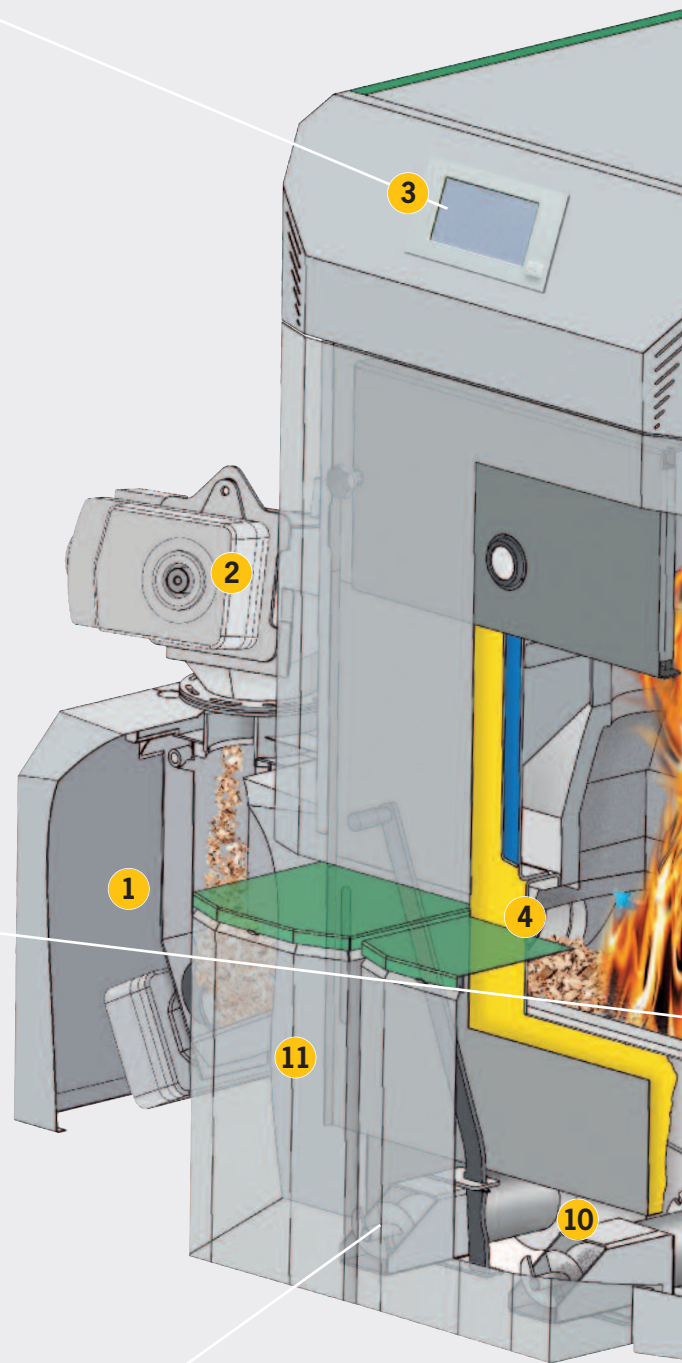

1. **Intermediate container** with infrared light barrier system (removes the need for mechanical level control)
2. **BBP** (back burn protection device; flap) **BBi** (back burn inhibit device; sprinkler system)
3. **T-CONTROL** central control unit

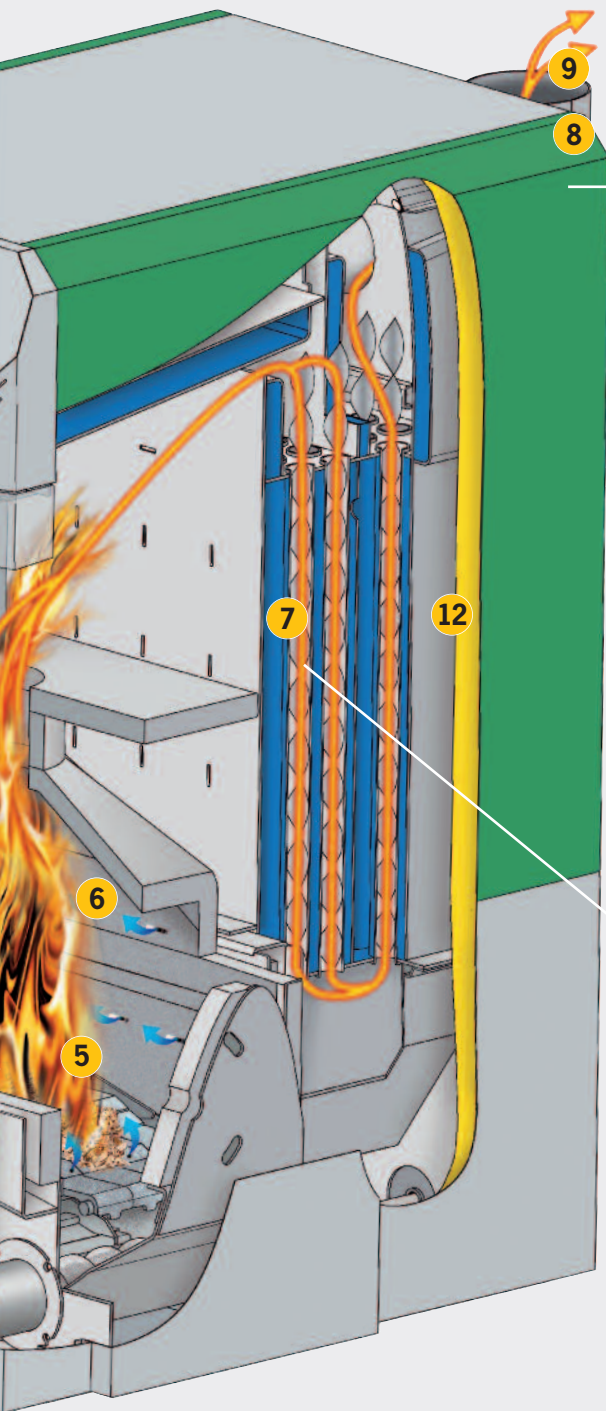

Energy saving combustion via the Lambda probe

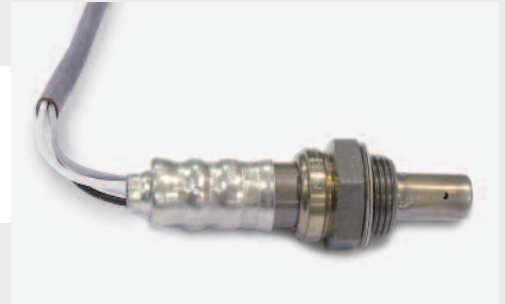

- Thanks to the in-built Lambda probe, which continuously monitors the flue gas values, the boiler reacts to changes in fuel quality ensuring optimum combustion and extremely low emission values.
- The Lambda probe controls the primary and secondary air supply ensuring complete combustion, even in partial load operation.
- The results are low fuel consumption and the lowest emission values even with different fuel qualities.

Automatic cleaning of the heat exchanger



- The heat exchanger surfaces are automatically cleaned via the integrated turbulators, even during heating operation, eliminating manual cleaning.
- A consistently high level of efficiency thanks to cleaned heat exchanger surfaces enables low fuel consumption.
- Falling ash is taken into the ash bin via an auger.

4. Automatic ignition
using hot air fans

5. Step- / moving grate
with automatic cleaning

6. Split 2-zone combustion chamber

7. Pipe heat exchanger
with turbulators and automatic cleaning

8. Lambda probe control
Automatic flue and combustion monitoring

9. Draft fan
speed controlled and monitored for the highest operating safety

10. Ash discharge screws
for combustion and fly ash

11. 2 front ash boxes

12. Efficient heat insulation
for the lowest radiated heat loss

Discharge and transport systems...

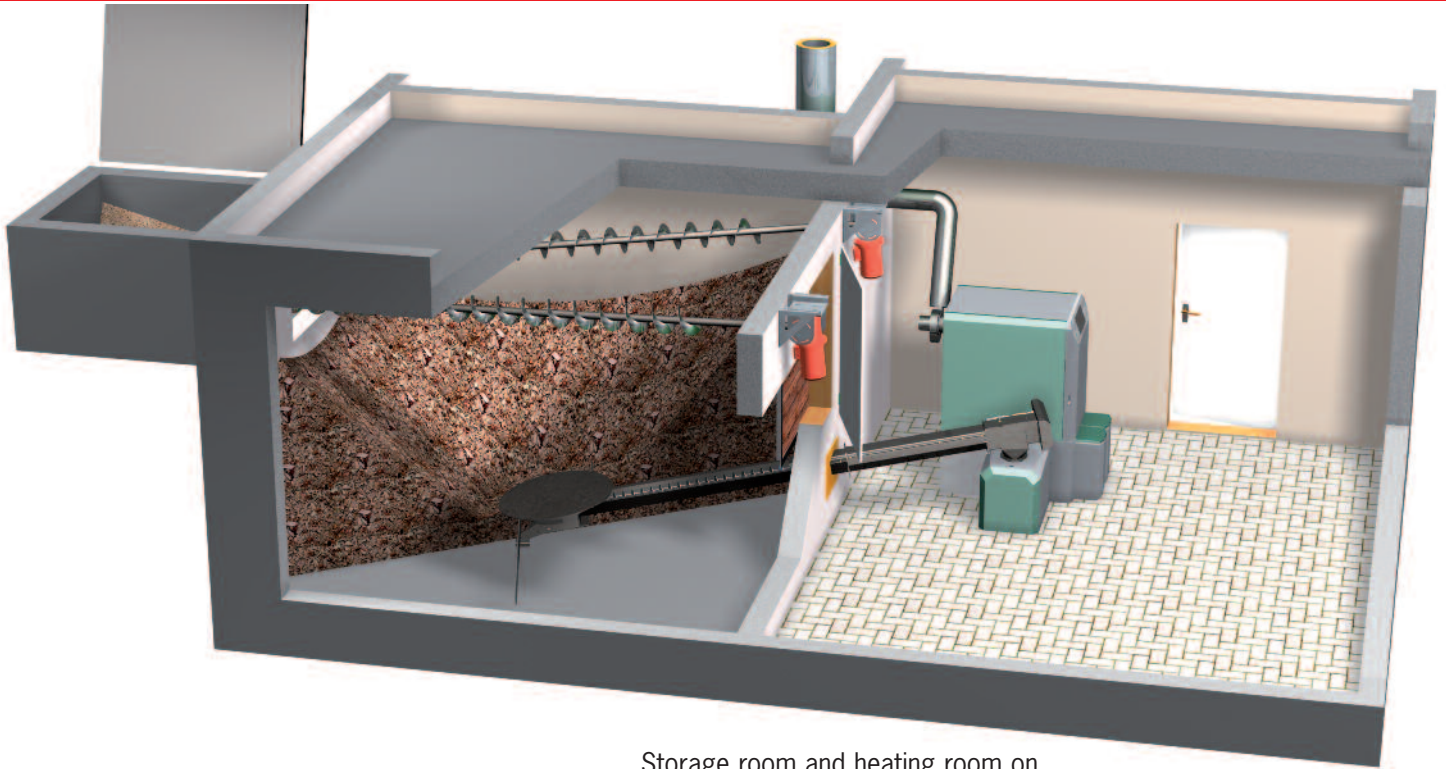

Storage room and heating room on same level. Transverse discharge with spring agitator and 2 filling screws.

HERZ spring agitator and drive technology:

Robust agitator with heavy gearing and pressure release for reliable operation. Spring agitator discharge up to 6m diameter for 3 x 400 V supply. Up to 5 m diameter for 230V operation for firematic 20-60 possible.

Additional discharge system via a pendulum screw from a silo, or a storage room discharge via hydraulic walking floor and straight auger screw available.

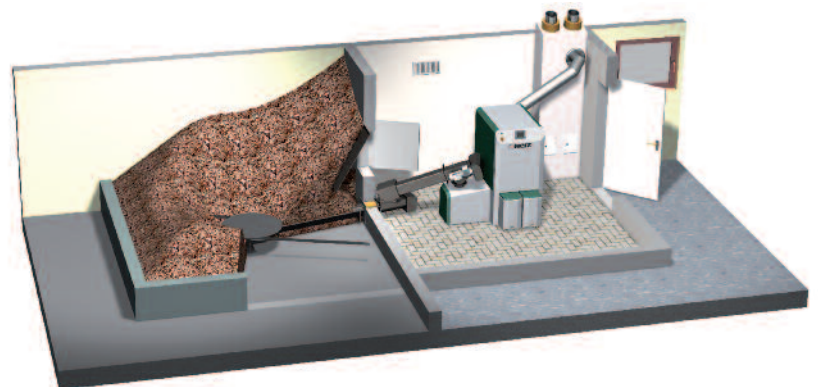

Room discharge via horizontal spring agitator with climbing screw for optimum storage room utilisation.

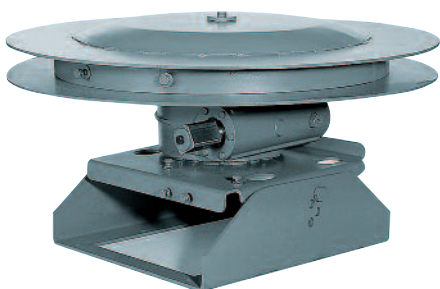

Storage room and boiler room at different levels. Horizontal discharge with spring agitator and chute pipe.

The vertical filling system of HERZ offers the opportunity to fill the storage room optimally.

Wood chips are fed via a vertical screw into the wood chip storeroom and are distributed optimally via a horizontal screw in the storage room.

Basic datas:

- Maximum fill trough length of 6m
- Modular extension of 0,6m and 1,2m possible
- Hinged, galvanized cover of the fill trough
- High corrosion resistant - fully galvanized panel for out door areas
- All engines are suitable for out door areas
- Vertical height up to 10 meters
- Perfectly distribution of the material in the bunker by a horizontal auger inside (up to 12 meters possible)

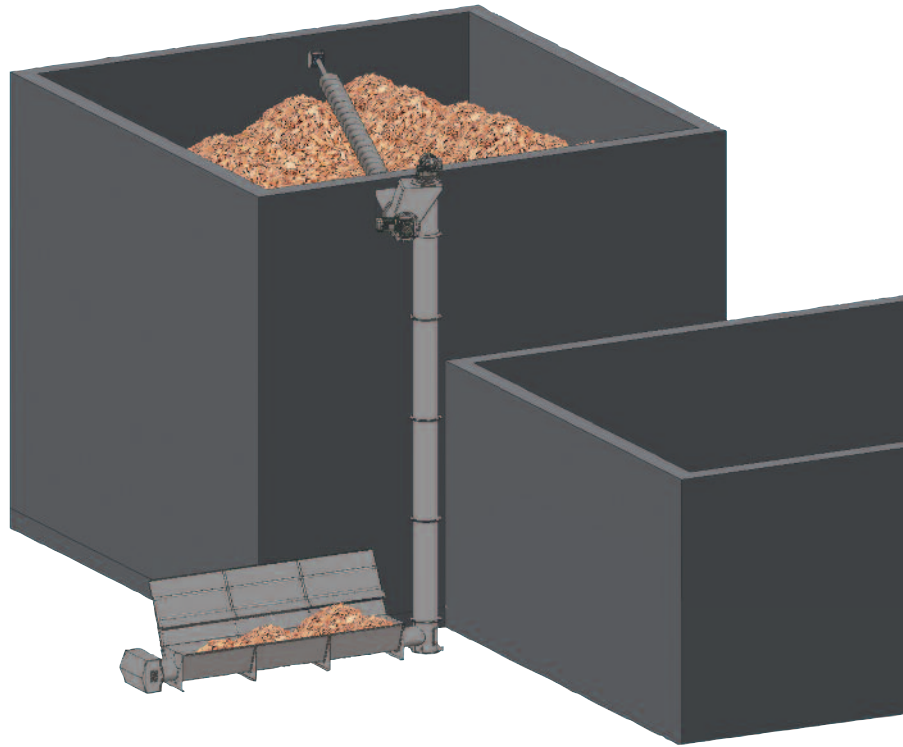

transport volume: <math>< 60\text{m}^3/\text{h}</math>
double systems: <math>< 120\text{m}^3/\text{h}</math>



Suitable fuels:

woodpellets according to

- EN 14961-2: property class A1
- Swissspellet, DINplus, ENplus or ÖNORM M7135

woodchips M40 (water content max. 40%) according to

- EN 14961-1/4: property class A1, A2, B1 and particle size P16B, P31,5 or P45A
- ÖNORM M7133: G30-G50



Discharge systems...



Discharge systems for pellets with flexible screw (till 201 kW)

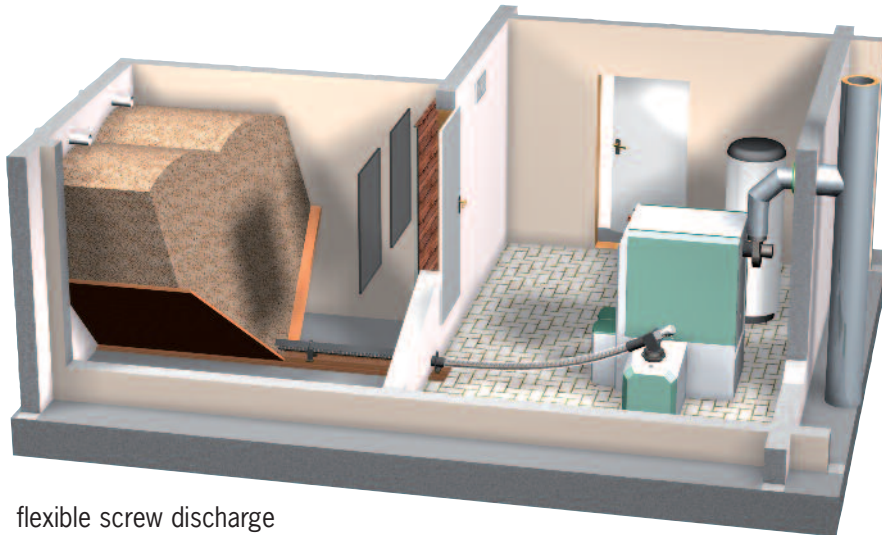

flexible screw discharge

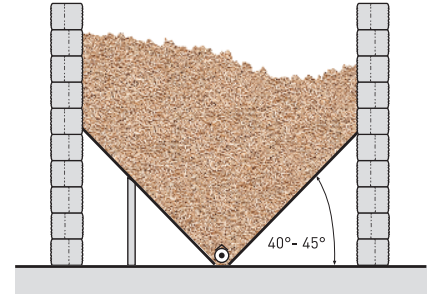

sliding angle of 40° - 45° in the pellet-store with a smooth surface

If the firematic is only used to burn pellets the flexible transport screw is a cheaper solution (in comparison with an agitator). To empty the storage room completely, we recommend making slidings. For this system no transport of woodchip is possible.

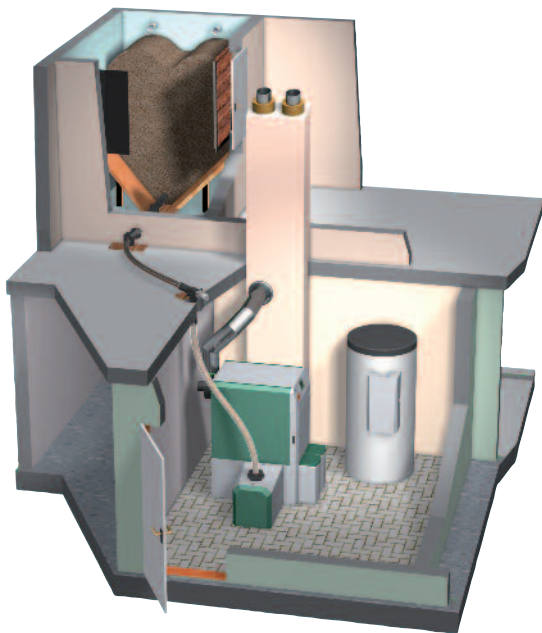

flexible screw discharge with chute pipe system

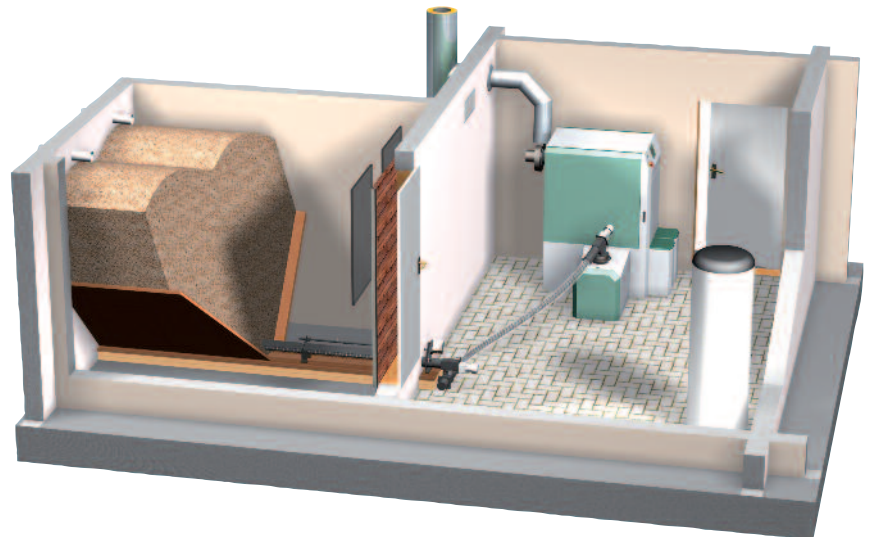

flexible screw discharge with transfer hopper (2 screws)

Agitator discharge - the useful system for wood chips and pellets.

If you want to burn wood chips in the system too, the discharge with an agitator has to be used. Nevertheless, if only pellets are used, the agitator system also can be used.

The advantage with an agitator is the efficient utilization of storage space and the possibility that the boiler can be filled with wood chips too.





... for pellets

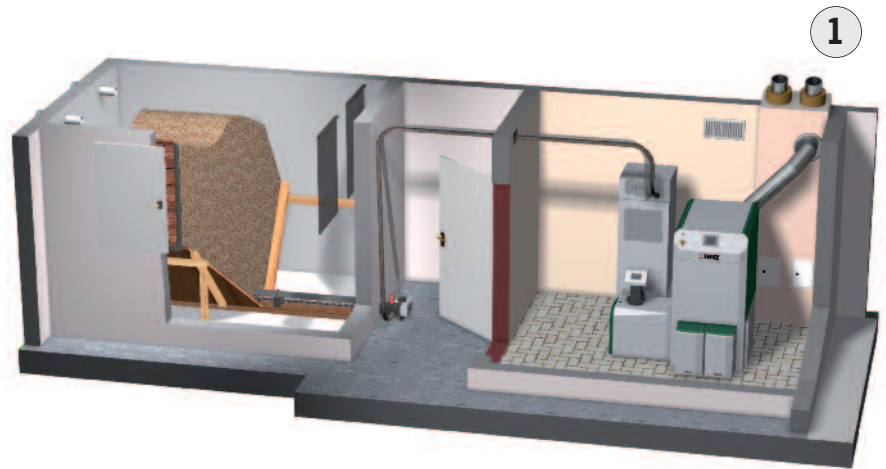

Modular pellet screw in the storage room (with slidings) and suction tank.

Pellets extraction via suction system (till 201 kW)

If the firematic is only used to burn pellets and the pellets have to be transported via a long distance from the storage room to the boiler room, the suction system is an optimal solution. Pellets can be transported up to a distance of max. 25 meters length and max. 5m height.

There are 3 possibilities to discharge the pellets out of the storage room:

- 1 an auger in the middle of the storage room (to empty the storage room completely, we recommend making slidings) or
- 2 an agitator for efficient storage space usage (for this case the slidings are not needed).
- 3 4-point suction system
The positioning of the 4 suction probes can be individually selected.

NOTE: For double-suction hoppers (necessary for firematic 130-201 kW) 2 discharge systems are necessary (for example 2 agitators, 2 screws, 2 4-point suction systems)

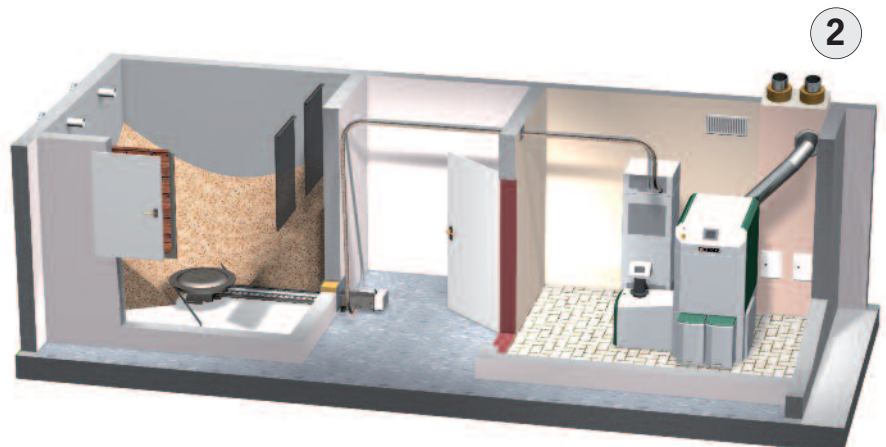

Pellet agitator in the storage room with suction discharge and suction hopper. Efficient use of storage space by eliminating the slip angles.

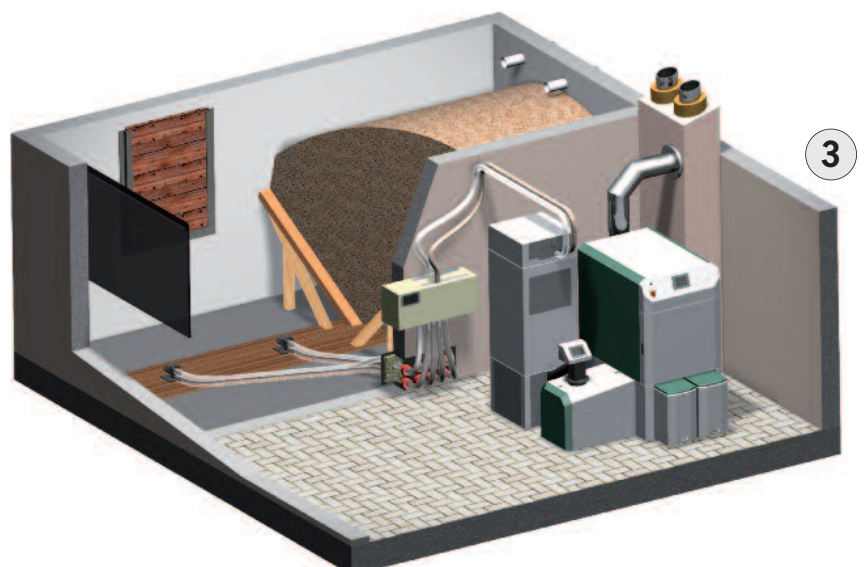

4-point suction system – The system can be easily installed, is adaptable to different storageroom situations and is an universal solution.

A range for all requirements...

The HERZ T-CONTROL:

The control enables a variety of application options, and two of the most frequent are shown below.

The installation of a buffer tank considerably increases the efficiency of the heating system, especially during periods of partial load. The variable heat loads from the different heating circuits (e.g. radiators and under floor heating) can be met readily from the buffer.

The differential temperature control and weather-driven control optimise energy usage allowing environmentally friendly and energy saving heating.

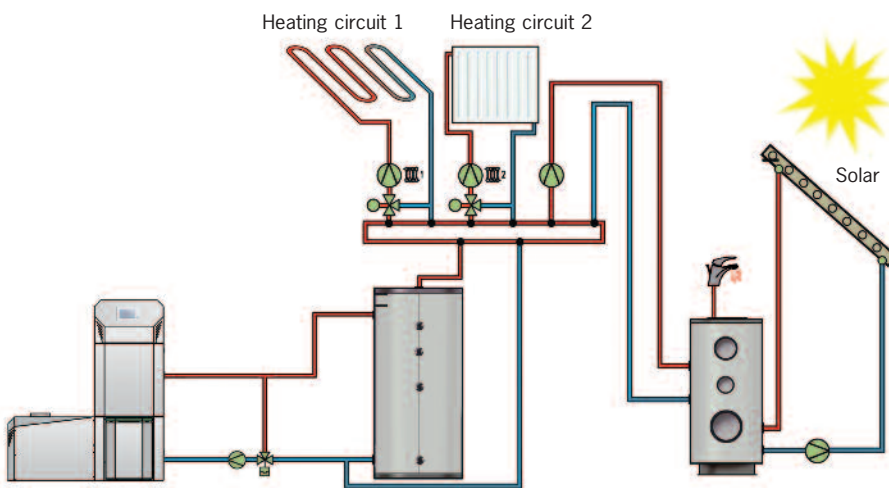

Hot water storage with solar usage and buffer storage:

With this system configuration solar energy is utilised to provide the domestic hot water. When the solar input is insufficient to meet the hot water demand, additional heat is taken from the buffer tank. Additional heating circuits such as under floor heating and the radiators are supplied with heat from the buffer tank.

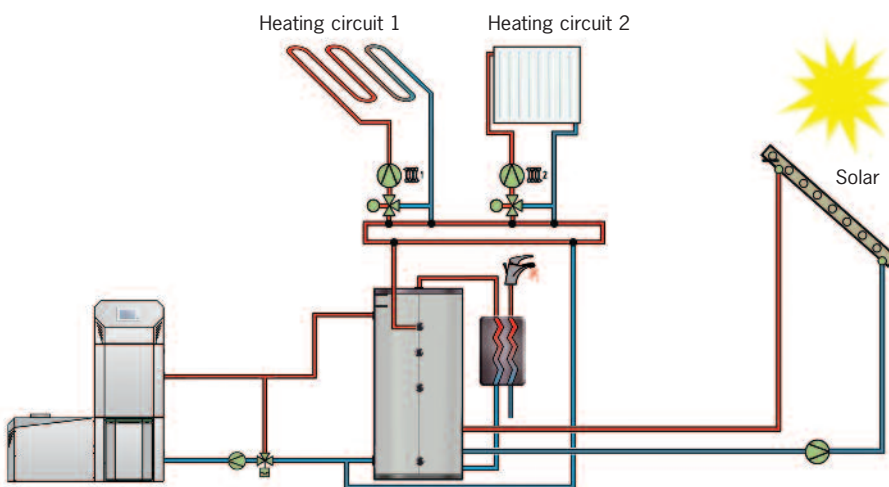

Solar heating support and hygienic hot water preparation:

With this system configuration the solar energy heats the water in the buffer tank directly. Domestic hot water is provided using a heat exchanger. Additional heating circuits such as under floor heating and the radiators are supplied with heat from the buffer tank.

HERZ continuous-flow water heater & buffer tanks

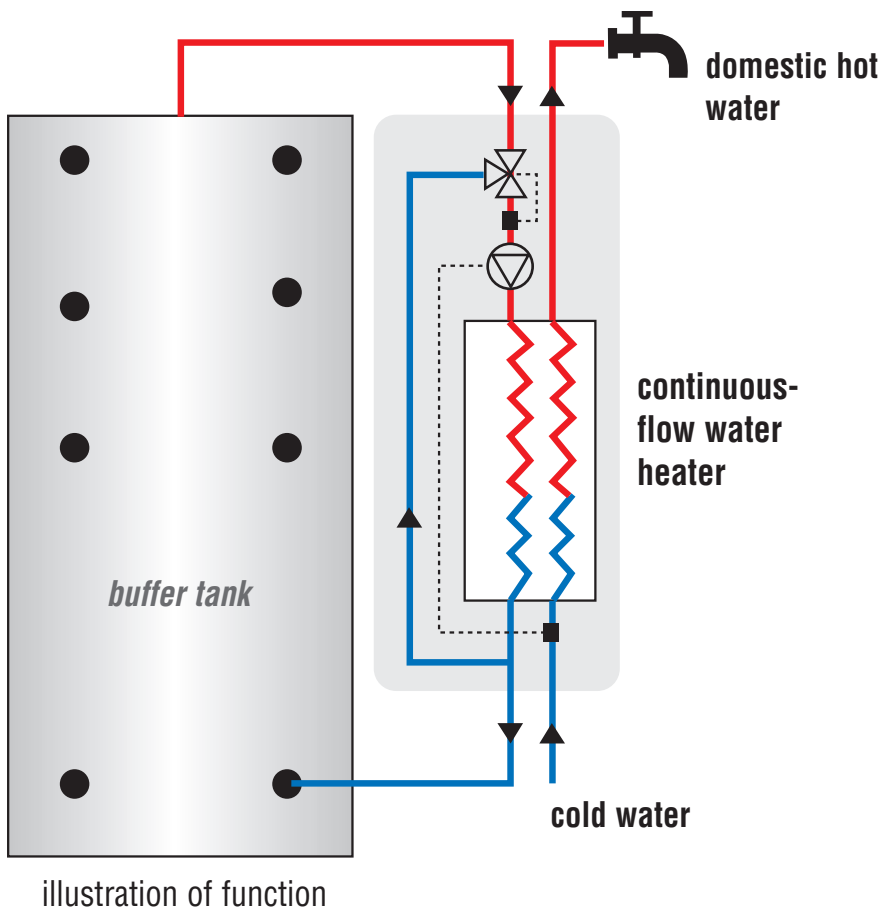

The HERZ continuous-flow water heater prepares the domestic hot water in an efficient way. The fresh cold water is heated up via a plate heat exchanger with water from the buffer tank.

The fresh water module is characterized by its compact design, low pressure drop, low water content and is easy to install

The advantages:

- Domestic hot water – hygienic & fresh
- Easy to install
- very compact (low space required)

Useful supplementation for your heating system: HERZ buffer tanks

Integrating a buffer tank into the system provides an energy store. It reduces the number of boiler start-ups, guarantees a continuous heat leak, and allows the boiler to optimise when it turns on.

Using a buffer store, continuous power generation can be sustained for a longer period. Thus frequent cycling of the boiler can be avoided and the level of efficiency improved.

Ash discharge into an external box - 240 liters



For even more comfort, there is the possibility of fully automatic ash removal into an ash container with a volume of 240 liters

With a flexible screw the combustion and fly ash is transported automatically into an ash container with a capacity of 240 liters.

Due to the bigger volume of ash container the intervals for empty the containers are not so often. Therefore it saves time and increases the comfort.

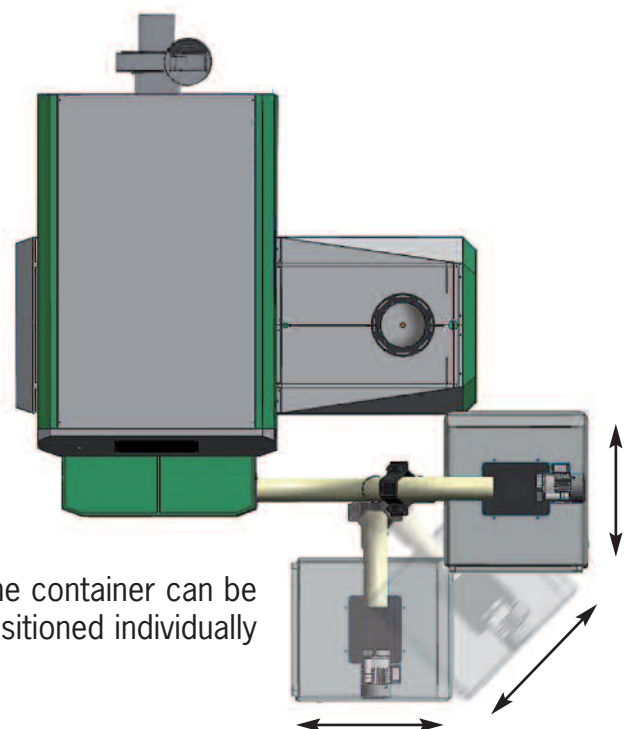

The container can be positioned individually

Dimensions & technical data firematic 20-60

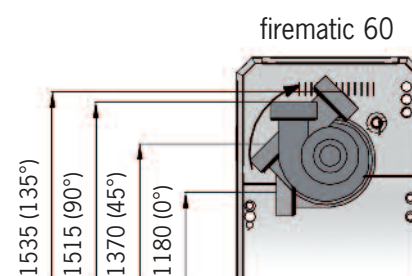
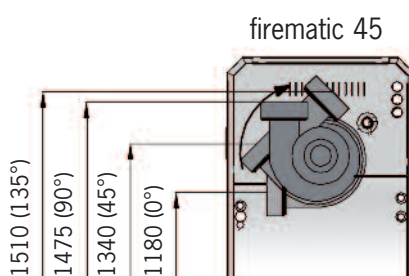
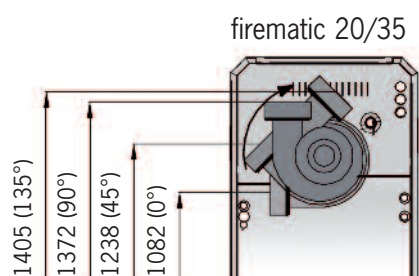
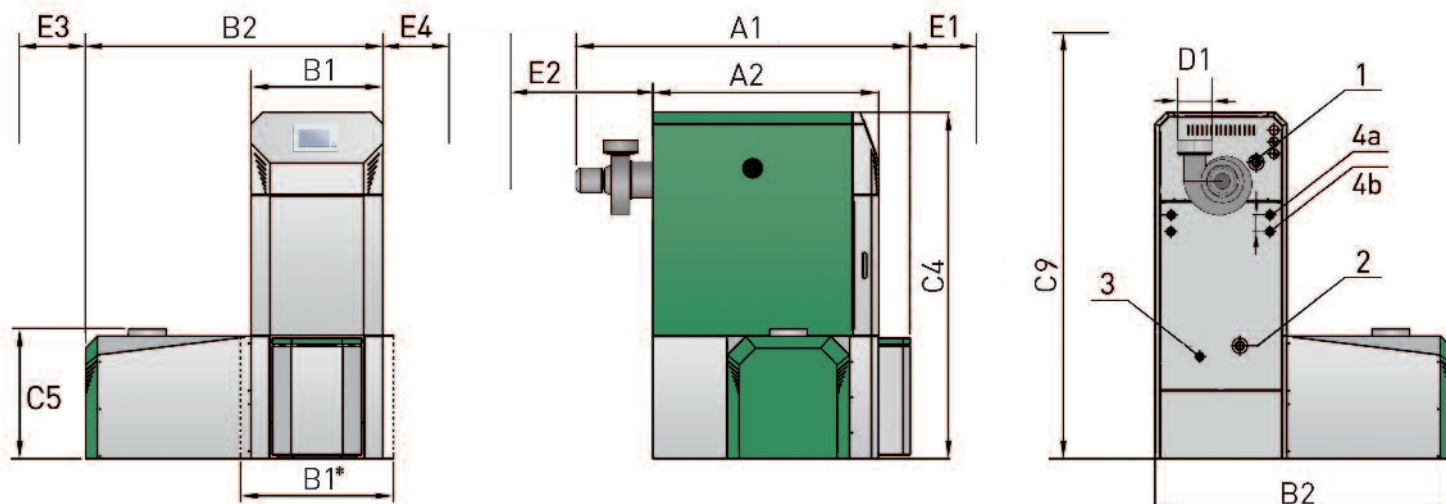

firematic 20-60

Technical data		20	35	45	60
Output range WOODCHIPS (kW)		6,0-20	6,0-35	12,1-45	12,1-60
Output range PELLETS (kW)		-	10,2-40	13,9-48	13,9-70
Dimensions (mm)					
A1	length - total	1389	1389	1495	1495
A2	length - casing	960	960	1070	1070
B1	width	600	600	710	710
B1*	Bring In wide with removal of components	-	-	-	-
B1*	Bring In wide with the casing (without casing removal)	621	621	731	731
B2	width - with push-in	1300	1300	1410	1410
C4	height	1490	1490	1590	1590
C5	delivery - upper edge	646	646	646	646
C9	Minimum room height	2100	2100	2300	2300
D1	flue pipe - diameter	150	150	150	180
E1	Minimum space at the front	600	600	700	700
E2	Minimum space at the back	500	500	530	530
E3	Minimum space left	300	300	300	300
E4	Minimum space right	300	300	300	300
Technical data					
Boiler weight	kg	517	517	620	620
Degree of efficiency η_p	%	>94	>93	>96	>96
Permissible operating pressure	bar	3,0	3,0	3,0	3,0
Max. permissible operating temperaturer	°C	95	95	95	95
Water capacity	ltr.	80	80	116	116
Flue gas mass flow rate at full load: woodchips (woodpellets)	kg/s	0,014 (-)	0,023 (0,027)	0,026 (0,024)	0,035 (0,036)
Flue gas mass flow rate at partial load: woodchips (woodpellets)	kg/s	0,004 (-)	0,004 (0,009)	0,008 (0,009)	0,008 (0,009)

firematic 20-35:

- 1... Flow, 1" IG
- 2... Return, 1" IG
- 3... Filling / draining connection, 1/2" IG
- 4a... Safety heat exchanger input, 1/2" IG
- 4b... Safety heat exchanger output, 1/2" IG

firematic 45-60:

- 1... Flow, 6/4" IG
- 2... Return, 6/4" IG
- 3... Filling / draining connection, 1/2" IG
- 4a... Safety heat exchanger input, 1/2" IG
- 4b... Safety heat exchanger output, 1/2" IG

IG...Interior thread

Dimensions & technical data firematic 80-499

firematic 80-301

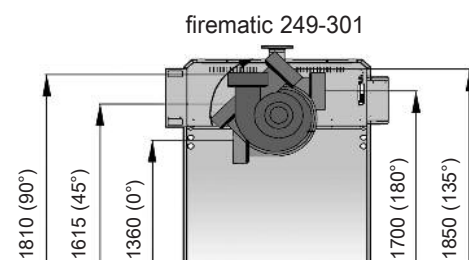
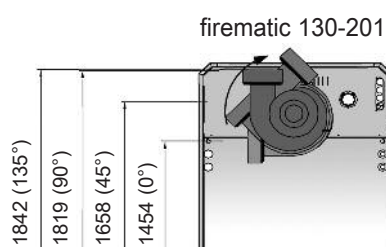
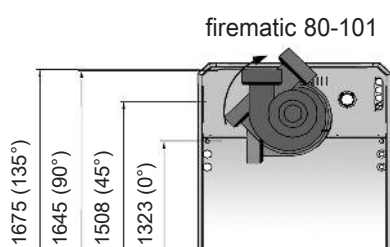
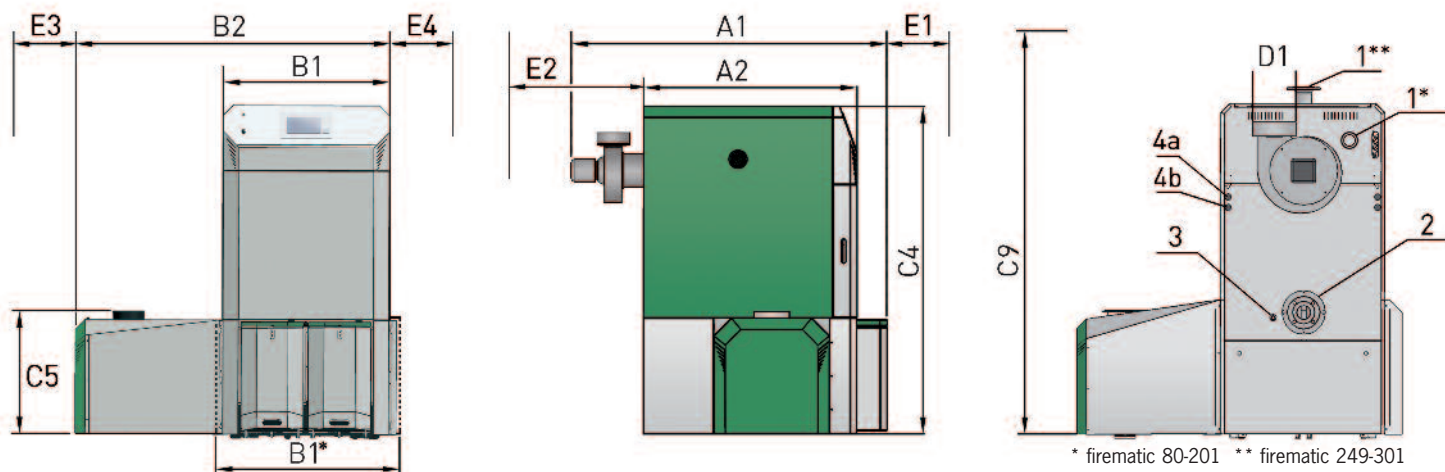

firematic 80-149

Technical data	80	100	101	130	149	151	180
Output range WOODCHIPS (kW)	23,2-80	23,2-99	23,2-101	36,7-130	36,7-149	36,7-151	36,7-180
Output range PELLETS (kW)	23,2-80	23,2-99	23,2-101	35,9-130	35,9-149	35,9-151	35,9-183
Dimensions (mm)							
A1 length - total	1709	1709	1709	2071	2071	2071	2071
A2 length - casing	1178	1178	1178	1494	1494	1494	1494
B1 width	846	846	846	980	980	980	980
B1* Bring In wide with removal of components	800	800	800	950	950	950	950
B1* Bring In wide with the casing (without casing removal)	907	907	907	1024	1024	1024	1024
B2 width - with push-in	1636	1636	1636	1888	1888	1888	1888
C4 height	1690	1690	1690	1818	1818	1818	1818
C5 delivery - upper edge	646	646	646	765	765	765	765
C9 Minimum room height	2300	2300	2300	2400	2400	2400	2400
D1 flue pipe - diameter	180	180	180	200	200	200	200
E1 Minimum space at the front	800	800	800	1000	1000	1000	1000
E2 Minimum space at the back	450	450	450	600	600	600	600
E3 Minimum space left	300	300	300	300	300	300	300
E4 Minimum space right	700	700	700	700	700	700	700
Technical data							
Boiler weight	kg	1032	1032	1032	1370	1370	1370
Degree of efficiency η_F	%	>94	>94	>94	>94	>95	>95
Permissible operating pressure	bar	3,0	3,0	3,0	5,0	5,0	5,0
Max. permissible operating temperature	°C	95	95	95	95	95	95
Water capacity	ltr.	179	179	179	254	254	254
Flue gas mass flow rate at full load:	kg/s	0,046	0,057	0,057	0,076	0,089	0,089
woodchips (woodpellets)		(0,046)	(0,059)	(0,059)	(0,079)	(0,087)	(0,105)
Flue gas mass flow rate at partial load:	kg/s	0,015	0,015	0,015	0,023	0,023	0,023
woodchips (woodpellets)		(0,016)	(0,016)	(0,016)	(0,022)	(0,022)	(0,022)



Suitable fuels:

woodchips M40 (water content max. 40%)
 firematic 20-499 – EN 14961-1/4: property class A1, A2, B1, particle size P16B, P31,5 or P45A
 – ÖNORM M7133: G30-G50

woodpellets
 firematic 20-60 – EN 14961-2: property class A1
 – Swisspellet, DINplus, ENplus or ÖNORM M7135
 firematic 80-499 – EN 14961-2: property class A1, A2
 – Swisspellet, DINplus, ENplus or ÖNORM M7135

firematic 80-101:
 1... Flow, 2" IG 2... Return, 2" IG
 3... Filling / draining connection, 3/4" IG
 4a... Safety heat exchanger input, 1/2" IG
 4b... Safety heat exchanger output, 1/2" IG

Dimensions & technical data firematic 80-499

firematic 349-499

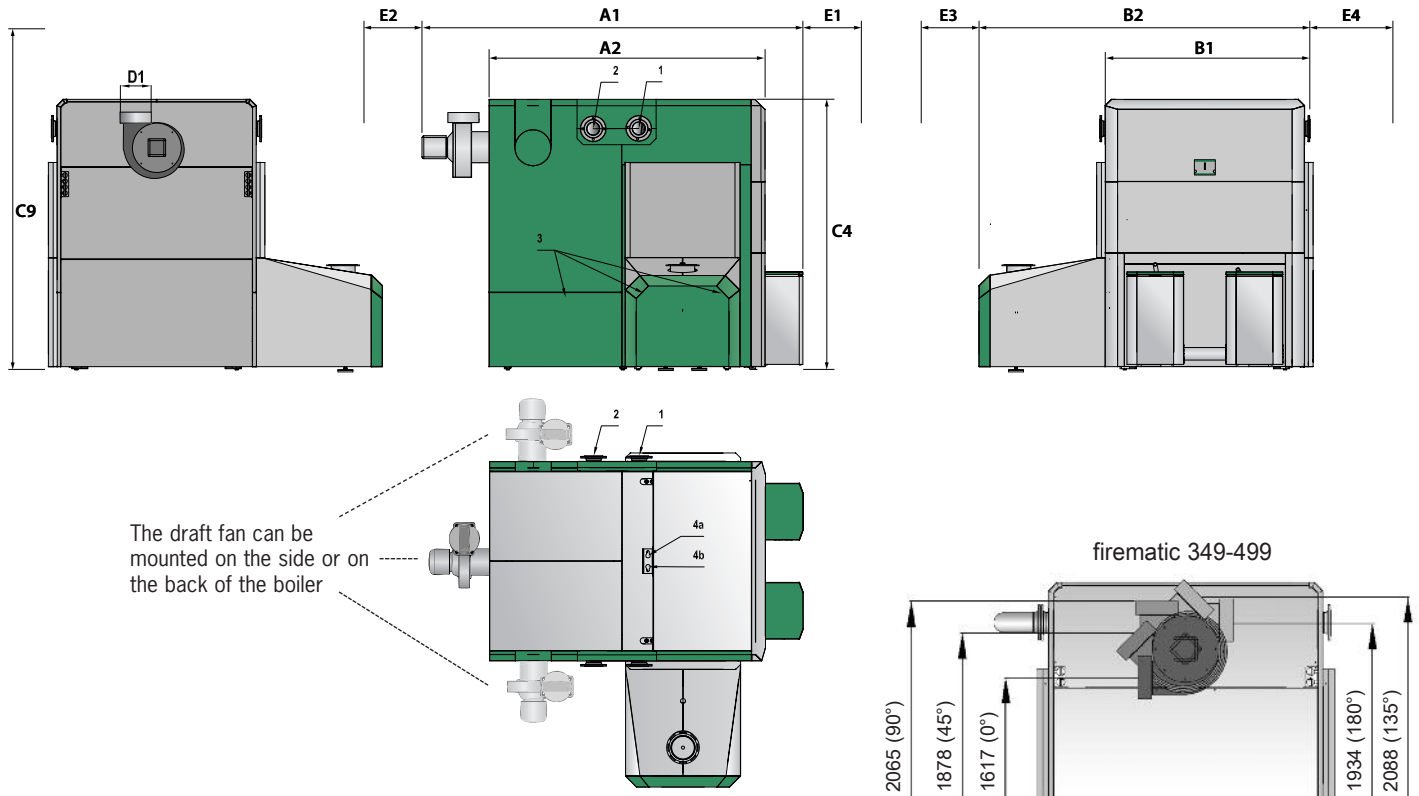

firematic 151-499

	199	201	249	251	299	301	349*	401*	499*
	36,7-199 35,9-199	36,7-201 35,9-201	69,6-249 76,8-256	69,6-251 76,8-256	69,6-299 76,8-299	69,6-301 76,8-301	104,7-349 104,7-349	104,7-401 104,7-401	104,7-499 104,7-499
Dimensions (mm)									
A1	2071	2071	2672	2672	2672	2672	3015	3015	3015
A2	1494	1494	1906	1906	1906	1906	2260	2260	2260
B1	980	980	1116	1116	1116	1116	1610	1610	1610
B1*	950	950	1065	1065	1065	1065	-	-	-
B1*	1024	1024	1230	1230	1230	1230	1200	1200	1200
B2	1888	1888	2096	2096	2096	2096	2655	2655	2655
C4	1818	1818	1911	1911	1911	1911	2175	2175	2175
C5	765	765	765	765	765	765	840	840	840
C9	2400	2400	2600	2600	2600	2600	2800	2800	2800
D1	200	200	250	250	250	250	250	250	250
E1	1000	1000	1000	1000	1000	1000	1000	1000	1000
E2	600	600	800	800	800	800	700	700	700
E3	300	300	300	300	300	300	500	500	500
E4	700	700	700	700	700	700	900	900	900
Technical data									
kg	1370	1370	2264	2264	2264	2264	4171	4171	4171
%	>93	>93	>94	>94	>93	>93	>93	>93	>93
bar	5,0	5,0	5,0	5,0	5,0	5,0	5,0	5,0	5,0
°C	95	95	95	95	95	95	95	95	95
ltr.	254	254	436	436	436	436	1200	1200	1200
kg/s	0,119 (0,114)	0,119 (0,114)	0,145 (0,165)	0,145 (0,165)	0,177 (0,193)	0,177 (0,193)	0,28 (0,256)	0,299 (0,273)	0,372 (0,340)
kg/s	0,023 (0,022)	0,023 (0,022)	0,045 (0,05)	0,045 (0,05)	0,045 (0,05)	0,045 (0,05)	0,098 (0,09)	0,098 (0,09)	0,098 (0,09)

*available on request – The right to make technical amendments is reserved.

firematic 130-201:

- 1... Flow, 2" IG
- 2... Return, 2" IG
- 3... Filling / draining connection, 3/4" IG
- 4a... Safety heat exchanger input, 1/2" IG
- 4b... Safety heat exchanger output, 1/2" IG

firematic 249-301:

- 1... Flow, DN80, PN 6
- 2... Return, DN80, PN 6
- 3... Filling / draining connection, 3/4" IG
- 4a... Safety heat exchanger input, 1/2" IG
- 4b... Safety heat exchanger output, 1/2" IG

firematic 349-499:

- 1... Flow, DN100, PN 6
- 2... Return, DN100, PN 6
- 3... Filling / draining connection, 3/4" IG
- 4a... Safety heat exchanger input, 1/2" IG
- 4b... Safety heat exchanger output, 1/2" IG

IG...Interior thread

HERZ Customer-orientated...



- Advice during planning
- Planning of energy centre and fuel storage room
- Planning of chamber discharge according to customer requirements and local conditions
- Planning of installation according to customer requirements
- Comprehensive services
- HERZ training:
 - for the machine operator
 - for designers and technical offices
 - for pipe fitters and installers
 - as well as continuous training of the maintenance staff

Business partners in:

- AUSTRIA
- BELGIUM
- BULGARIA
- CANADA
- CROATIA
- CZECH REPUBLIC
- DENMARK
- ESTONIA
- FINLAND
- FRANCE
- GERMANY
- GREAT BRITAIN
- GREECE
- HUNGARY
- IRELAND
- ITALY
- LATVIA
- LITHUANIA
- LUXEMBOURG
- NETHERLANDS
- NORWAY
- POLAND
- PORTUGAL
- ROMANIA
- RUSSIA
- SERBIA
- SLOVAKIA
- SLOVENIA
- SOUTH TYROL
- SPAIN
- SWEDEN
- SWITZERLAND
- UKRAINE



Your partner:



Heating at work.

Hamworthy Heating Ltd
 Fleets Corner, Poole, BH17 0HH
 Tel: 01202 662500
 Fax: 01202 662500

E-mail: sales@hamworthy-heating.com

Web: www.hamworthy-heating.com



HERZ Energietechnik GmbH
 Herzstraße 1, 7423 Pinkafeld
 Österreich/Austria
 Tel.: +43(0)3357/42840-0
 Fax: +43(0)3357/42840-190
 Mail: office-energie@herz.eu
 Internet: www.herz.eu



HERZ - biomass boilers exceed the strict emission regulations.

