

**WESSEX-HE 200
WESSEX-HE COUNTY**

**HOT WATER BOILER FOR HEATING AND
DOMESTIC
HOT WATER INSTALLATIONS**

**INSTALLATION, COMMISSIONING AND
SERVICING INSTRUCTIONS**

IMPORTANT NOTE

**THESE INSTRUCTIONS MUST BE READ
AND UNDERSTOOD BEFORE INSTALLING,
COMMISSIONING, OPERATING OR
SERVICING EQUIPMENT**

Customer Services

Technical Enquiries



01202 662527/662528

To supplement the detailed technical brochures, technical advice on the application and use of products in the Hamworthy Heating range is available from our technical team in Poole and our accredited agents.

Site Assembly



01202 662555

Hamworthy offer a service of site assembly for many of our products in instances where plant room area is restricted. Using our trained staff we offer a higher quality of build and assurance of a boiler built and tested by the manufacturer.

Commissioning



01202 662555

Commissioning of equipment by our own engineers, accredited agents or specialist sub – contractors will ensure the equipment is operating safely and efficiently.

Maintenance Agreements



01202 662555

Regular routine servicing of equipment by Hamworthy service engineers inspects the safety and integrity of the plant, reducing the risk of failure and improving performance and efficiency. Maintenance agreements enable our customers to plan and budget more efficiently.

Breakdown service, repair, replacement



01202 662555

Hamworthy provide a rapid response breakdown, repair or replacement service through head office at Poole and accredited agents throughout the UK.

Spare Parts



01202 662525

A comprehensive spare parts service is operated from our factory in Poole, providing replacement parts for both current and discontinued products. Delivery of parts and components is normally from stock within seven days. However, a next day delivery service is available for breakdowns and emergencies.

WESSEX-HE 200 WESSEX-HE COUNTY

**HOT WATER BOILER FOR HEATING AND
DOMESTIC
HOT WATER INSTALLATIONS**

**INSTALLATION, COMMISSIONING AND
SERVICING INSTRUCTIONS**

**NOTE: THESE INSTRUCTIONS SHOULD BE READ AND UNDERSTOOD BEFORE
ATTEMPTING
TO INSTALL, COMMISSION OR OPERATE THIS UNIT!**

**THE WESSEX BOILER IS INTENDED FOR USE AS A COMMERCIAL APPLIANCE
INSTALLED IN A SEPARATE BOILERHOUSE WITH ADEQUATE VENTILATION AND IS NOT CERTIFIED
FOR USE IN DOMESTIC APPLICATIONS**

**THIS BOILER IS FOR USE ON GROUP H NATURAL GAS (2ND FAMILY) I_{2H} AND
LPG - PROPANE (3RD FAMILY) I_{3P}. PLEASE ENSURE RELEVANT
INFORMATION REQUIRED WITHIN THIS DOCUMENT IS FOUND
RELATING TO SPECIFIC GAS TO BE FIRED BEFORE FIRING THE BOILER.**

THIS BOILER COMPLIES WITH ALL RELEVANT EUROPEAN DIRECTIVES

**EC TYPE CERTIFICATE NO. BG/EC - 87/95/30/M6
EC IDENTIFICATION NO. 87AQ30**

**PUBLICATION NO. 500001008
ISSUE 'K'
August 2005**

**FOR BOILERS COMMENCING
MODULE SERIAL NO. CC-XXXX-5000**

CONTENTS

PAGE

Front Page	i
Contents	ii
1.0 INTRODUCTION	1
2.0 TECHNICAL DATA	1
2.1 Overall Dimensions	
2.2 Technical Data Table	
3.0 GENERAL REQUIREMENTS	2
3.1 Related Documents	
4.0 LOCATION	4
5.0 GAS SUPPLY	4
5.1 Service Pipes	
5.2 Gas Supply Pipes	
5.3 Boilerhouse Control Valve	
5.4 Boiler Gas System Leak check	
6.0 FLUE SYSTEM	5
6.1 Suction	
6.2 Design Waste Gas Volume and Temperature	
6.3 Flue Condensation	
6.4 Surface Temperature	
6.5 Flue Pipe Location	
7.0 AIR SUPPLY	6
7.1 Air Supply by Natural Ventilation	
7.2 Air Supply by Mechanical Ventilation	
8.0 WATER CIRCULATION SYSTEM	7
8.1 General	
8.2 Pressure Relief Valve	
8.3 Open Vent Pipe and Cold Feed Pipe	
8.4 Altitude Gauge (Water Pressure Gauge)	
8.5 Thermometer	
8.6 Drain Taps	
8.7 Circulating Pump	
8.8 Minimum Water Flow Rates	
8.9 Waterside Pressure Drop	
8.10 Control Schemes	
8.11 Minimum Water System Pressure	
8.12 Unvented Pressurised Systems	

9.0	ELECTRICAL SUPPLY	9
9.1	Mains Cable Connection	
9.2	Boiler Wiring Diagram	
9.3	Indication Signals and Volt Free Contacts	
10.0	INSTALLATION OF BOILERS	10
10.1	General	
10.2	Connection of Boilers to the Flue System	
10.3	Gas Connections	
11.0	COMMISSIONING AND TESTING	11
11.1	Electrical Installation	
11.2	Gas Installation	
11.3	Water Circulation System	
11.4	Lighting the Boiler (Initial Commissioning) and System Leakage Check	
11.5	Gas Pressure, Adjustment and Combustion Checks	
11.6	Limit Thermostat Adjustment	
1	External Controls	
2	Installation Noise	
11.7	User's Instructions	
12.0	FAULT FINDING	13
12.1	Summary of Safety Features	
12.2	Fault Finding	
12.3	Causes of Lockouts	
13.0	SERVICING	14
14.0	REPLACEMENT OF FAILED COMPONENTS	18
14.1	RECOMMENDED SPARES	21
Appendix 'A'	Information Relating to Propane Firing	31

FIGURES: -

1	Gas valve Leak test procedure	5
2	Schematic Boiler Installations (Typical)	22
3	Wessex 200 HE Module Waterside Pressure Loss	23
4	Terminal Identification & Mains Cable Layout.....	24
5	Wiring Diagram (Schematic)	25
6	Wessex 200 HE Module Layout.....	26
7	Sequence Controller Coloured Programme Indicator Disc.....	27
8	Wessex 200 HE Burner Flow System Schematic.....	27
9	Boiler Dimensions & Clearances	28
10	Wessex 200 HE Pilot Burner Assembly.....	29
11	Wessex 400 County Arrangement Drawing.....	30

1.0 INTRODUCTION

1.1 These **instructions** are for use with Group H Natural Gas (2nd Family) and LPG - Propane (3rd Family). The information relative to Propane firing is to be found in Appendix 'A'. Boilers **MUST NOT** use gas other than that for which they were designed and built.

The Wessex HE is a gas fired, fan assisted, open flued central heating/hot water boiler comprising of a burner and water tube bank assembly (module). The Wessex-HE 200 range consists of a single 200kW unit and a vertically stacked double module mounted in a common casing (Wessex-HE 400 County).

The boiler is designed for direct connection to a flue system. Flue outlets from more than one boiler may be connected to a single chimney, providing the relevant requirements of the current Building Regulations are adhered to. No draught diverter is fitted to the boiler nor is a fixed diverter required in the flue system. However a draught stabiliser is recommended for some installations (see Section 6.1) The Wessex-HE boiler is floor mounted and is intended for the heating of Commercial and Industrial premises. It may also be used to supply hot water via an indirect cylinder.

The Wessex-HE has a low water content and water flow rates **MUST** be maintained at or above the minimum levels shown in Section 8 and Fig. 3.

1.2 This boiler must be installed and serviced by a competent person holding "CORGI" registration or equivalent. All installations must conform to the relevant Safety and Building Regulations. HSE requirements must also be taken into account when installing any equipment.

Failure to comply with the above may lead to Prosecution.

1.3 If the boiler is to be connected to an unvented (Pressurised) heating system, care must be taken to ensure all extra safety requirements are met and that the relevant interlocks will shut down the boiler(s) should a high or low pressure fault occur.

The Pressurisation unit must also incorporate a low level water switch that protects the water pumps and will directly or indirectly shut down the boiler plant should a low water condition occur.

Consideration should also be given to the maximum working pressure of the boiler as given in Section **2: TECHNICAL DATA**. Consult Hamworthy Heating Technical Department for help or assistance if in doubt.

2.0 TECHNICAL DATA

The Technical Data Table relating to Propane firing can be found in Appendix 'A'.

2.1 Overall Dimensions

For overall dimensions and layout of the Wessex-HE 200 refer to Figure No. 9.

For overall dimensions and layout of the Wessex-HE 400 County refer to Figure No. 11.

2.2 Technical Data Table (Natural Gas - G20)

GENERAL DATA Wessex-HE 200 Series	BOILER MODEL	
	Wessex-HE 200	Wessex-HE County
Boiler Input kW (Gross) - maximum	238	476
Boiler Input kW (Nett) - maximum	215	429
Boiler Output kW - maximum	200	400
FLUE DATA		
Nominal Flue Spigot Internal Dia. (mm)	344	358
Approx. Flue Gas Temperature °C (Gross)	125	
Approx. Flue Gas Vol. (0°C – 1013mbar)@ 9.0% CO ₂ (m ³ /h)	288	576
GAS DATA		
Nominal Gas Inlet Press. (mbar)	20	
Maximum Gas Inlet Press. (mbar)	25	
Gas Flow Rate (m ³ /h)	22.7	45.4
Gas Setting Press. (mbar)	2.6	
Differential Pressure Switch Setting (mbar)	1.2 (Do not adjust)	
Orifice Dia. (mm)	18	
Gas Inlet Connection Pipe Thread Size	Rp1	
Pilot Injector Marking	200	
WATER DATA		
Water Connections (F&R) Flanged BS4504 PN6	80	
Waterside Pressure Loss @ 11°C DT Rise (mbar)	65	
Waterside Pressure Loss @ 15°C DT Rise (mbar)	105	
Maximum Water Pressure (barg)	6.0	
Water Content (not including headers) (litres)	20	40
System Design Flow Rate @ 11°C DT Rise (l/s)	4.28	8.56
Minimum Flow Rate @ 15°C DT Rise (l/s)	3.42	6.83
Shipping Weight (kg)	257	515
ELECTRICAL DATA		
Power Consumption @-230V AC 50Hz 1ph	250W	500W
Start and Run Current (per module)	< 3 Ampere	

3.0 GENERAL REQUIREMENTS

3.1 Related Documents - Gas Safety (Installations and Use) Regulations 1994 as amended 1996.

It is Law that competent persons in accordance with the above regulations install all gas appliances. Failure to install appliances correctly could lead to prosecution. It is in your own interest, and that of safety, to ensure that this law is complied with.

The installation of the boiler MUST be in accordance with the relevant requirements of the Gas Safety Regulations, Building Regulations, IEE Regulations and the bylaws of the local water undertaking.

It should also be in accordance with any relevant requirements of the HSE, the local gas region local authority and the relevant recommendations of the following documents:

British Standards Codes of Practice

BS 6891: Installation of low-pressure gas pipework of up to 28mm (R1) in domestic premises. (For larger installations see **UP/1**, **UP/1A** and **UP/2** below).

BS 6644: Installation of Gas Fired Hot Water Boilers - 60kW to 2MW.

BS 6700: Design, installation, testing and maintenance of services supplying water for domestic use.

BS 6880: Code of practice for low temperature hot water heating systems of output greater than 45kW.

BS 3456: (CEE 10 Part 1, CEE 11 Part 1) Electrical Standards.

CP 342: Centralised hot water supply.
Part 2: Buildings other than individual dwellings.

Institution of Gas Engineers Publications

IGE/UP/1: Soundness testing and purging of industrial and commercial gas installations.

IGE/UP/1A: Soundness testing and direct purging of small low pressure industrial and commercial Natural Gas installations.

IGE/UP/2: Gas installation pipework, boosters and compressors in industrial and commercial premises.

IGE/UP/10: Installation of gas appliances in industrial and commercial premises. Part 1: Flued appliances.

Health and Safety Executive

Guidance Note **PM5** - Automatically Controlled Steam and Hot Water Boilers.

CIBSE Publications

CIBSE Guide

It is impractical in this document to specify all relevant information, but the following extracts from the above references are emphasized since failure to comply with these requirements will almost certainly result in an unsatisfactory installation.

3.2 Feed Water Quality - If the boiler feed water has a high degree of hardness, it is recommended that the water be treated to prevent precipitation of scale or sludge in the boiler water passageways. Details of additives can be obtained from any reliable manufacturer of water treatment products or the local Water Authority.

It should be noted however, that even if the boiler water were of average hardness, not requiring

treatment, subsequent draining of the system for repair or constant make-up water due to an undetected leak would cause additional deposits and gradual build-up of scale. It is essential therefore, that leaks are attended to promptly and draining is kept to an absolute minimum.

It is recommended that the system be flushed out at least twice with hot water before any water treatment is added. If any doubt exists regarding the internal cleanliness of an old system, consideration should be given to the fitting of a coarse filter in the return pipework to the boilers.

3.3 Adequate Water Flow

Also refer to section 8.7.

The Hamworthy Wessex HE boiler is designed as a quick response, low water content unit, to run continuously with minimum or no operating problems. Care should be taken in the initial design and layout having due regard for adequate water flow through the boilers and the influence of any control systems in the pipework.

NOTE! The Standards Authority recommends a minimum return temperature of 50°C in all heating systems other than condensing boilers.

3.4 Time Clock Control

In order to avoid local overheating and progressive calcium deposition at zero flow conditions where boilers are operated by time clocks, provision should be made for a 3 minute circulating pump over-run after the last boiler has ceased firing.

NOTE! Time clocks should not interrupt live, neutral or earth connections. External voltage **MUST NOT** be applied to remote stop/start terminals C5 and C6.

4.0 LOCATION

(Refer to Figure Nos. 9 & 11 and section 10.1 for dimensions and clearances).

The location chosen for the boiler must permit the provision of a satisfactory flue system and an adequate air supply. The location must also provide adequate space for servicing and air circulation around each unit.

The boiler must be installed on a level non-combustible surface that is capable of adequately supporting its weight (when filled with water, see Table 2.2) and any ancillary equipment.

Any combustible material adjacent to the boiler and the flue system must be so placed or shielded as to ensure that its temperature does not exceed 65°C.

Further details regarding boiler location are given in **BS6644**.

5.0 GAS SUPPLY

5.1 Service Pipes

The local Gas Region must be consulted at the installation planning stage in order to establish the availability of an adequate supply of gas.

5.2 Meters

A new gas meter will be connected to the service pipe by the local gas region, or a local gas region contractor.

An existing meter should be checked, preferably by the gas region, to ensure that it is adequate to deal with the rate of gas supply required.

5.3 Gas Supply Pipes

Supply pipes must be fitted in accordance with **BS 6891** or **UP/2** as appropriate. Pipework from the meter to the boiler must be of adequate size. Do not use pipes of a smaller size than the boiler gas connection. The complete installation must be purged and tested for soundness as described in **BS 6891** or **UP/1** and **UP/1A** as appropriate.

5.4 Boosted Supplies

Where it is necessary to employ a gas pressure booster, the controls must include a low-pressure cut-off switch at the booster inlet. The local gas region must be consulted before a gas pressure booster is fitted.

5.5 Boiler House Control Valve

A manual valve for boiler house isolation shall be fitted in the gas supply line. It shall be clearly identified and readily accessible for operation.

5.6 Boiler Gas System Leak Check

Although the boiler receives a gas leak check and gas train component integrity check prior to leaving the factory, transport and installation may cause disturbance to unions, fittings and gas valve assemblies etc. and during commissioning a further test for soundness should be carried out on the boiler gas pipework and components. A procedure guide follows with reference to Figure No. 1.

To Check Valve D.

- 1) Turn off the electrical power supply to the appliance and close all valves.
- 2) Connect the manometer to TP1 on either of the main valves A or B (see Figure No. 1).
- 3) With A, B & C closed, open E and "Crack Open" D to produce 5 mbar on manometer.

4) Close D and monitor the manometer over a 2 minute period * - a rise would indicate a leak on valve D.

To Check Valves A, B & C.

1) Repeat using main gas supply pressure between A, B, C & D.

System A, B, C, D may be considered sound if over a period of 2 minutes any pressure drop is less than 0.5 mbar.

* **NOTE:** Allow a manometer stabilisation period of approximately 1-minute before each 2 minute check period.

Following soundness tests, remove manometer connections and tighten test point TP1.

NOTE: Care must be taken not to allow soapy water on or near any electrical parts or connections.

Figure No. 1 - Gas Valve Leak Check Procedure

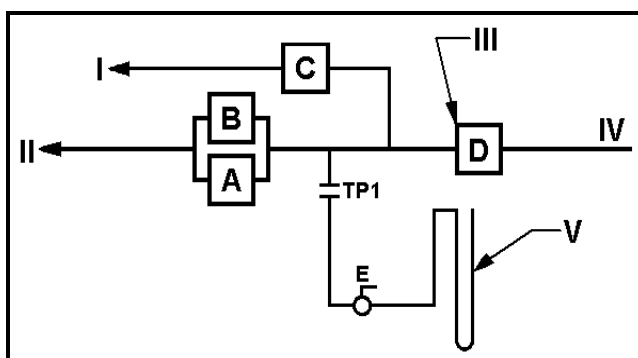

Key: -

- I - PILOT GAS BURNER
- II - MAIN GAS BURNER
- III - APPLIANCE ISOLATING VALVE
- IV - MAIN GAS SUPPLY =
 - NATURAL GAS (G20) - 20mbar
 - PROPANE (G31) - 37mbar
- V - MANOMETER

6.0 FLUE SYSTEM

Detailed recommendations for flue systems are given in **BS 6644** and Institution of Gas Engineers Publication **UP/10** "Installation of gas appliances in industrial and commercial premises Part 1: Flued appliances".

The following notes are intended to give general guidance only.

6.1 Suction

The flue system should be designed to maintain atmospheric pressure or a slight suction at the boiler flue connection at all times. It is recommended that a draught stabiliser is fitted to the flue system where the suction is likely to exceed 0.1mbar or the height of the flue exceeds 4metres.

6.2 Exhaust Gas Volume and Temperatures

The volumes, etc. relating to Propane firing can be found in Appendix 'A'.

It is recommended that the volume and temperature of the waste gases shown in Table 2.2 are used for the design of the flue system.

6.3 Flue Condensation

Due to the high thermal efficiency of the boiler, the flue gas temperature is approx.125°C. Condensation in the flue is thus more likely than with lower efficiency boilers. It is strongly recommended that twin-wall or insulated flue pipe is used on all installations. Care should be taken to ensure that the flue is installed such that any condensation is continuously drained. All flues should have a minimum slope of 2½° upwards in the direction of exhaust gas flow (no horizontal sections). All joints should be such that any condensation is directed back down the slope. The drain fitted to the Wessex 200 HE boiler casing is 22mm O/D (16mm I/D) and will take an appropriate compression fitting (The County has a Rc¾ socket connection). It will adequately cope with condensation from 6 metres of twin-wall flue, any longer lengths of flue should have separate open drain connections. The drainpipe must be manufactured from a non-corrosive material and be at least 15.0mm dia. It must also have a fall of at least 3°(approx. 50mm per metre) and connect to a drain via a waste trap.

6.4 Materials

Materials used for the flue system must be asbestos free, mechanically robust, resistant to internal and external corrosion, non-combustible and durable under the conditions to which they are likely to be subjected.

6.5 Disconnection

Facilities must be made for disconnecting the flue pipe from each boiler for inspection and servicing purposes. Bends with removable covers should be fitted for inspection and cleaning purposes where considered appropriate. Flues must be adequately supported and protected from damage. They must not present a risk to people in or about the building.

6.6 Flue Discharge

The flue system must ensure safe and efficient operation of the boiler to which it is attached, protect the combustion process from wind effects and disperse the products of combustion to the external air.

The flue must terminate in a freely exposed position and be so situated as to prevent the products of combustion entering any opening in a building.

Where the flue diameter is less than 200mm a terminal should be fitted. Where the flue is of a larger size consideration should be given to the fitting of a terminal.

6.7 Surface Temperatures

Combustible materials in the vicinity of the boiler and flue shall not exceed 65°C during boiler operation. The flue shall not be closer than 50mm to any combustible material, except where it passes through such material with a non-combustible sleeve when the air gap may not be less than 25mm.

6.8 Flue Pipe Location

The flue must not be placed or fitted where there is undue risk of accidental damage to the flue pipe or undue danger to persons in the vicinity.

Note! The flue MUST be self-supporting.

7.0 AIR SUPPLY

Detailed recommendations for air supply are given in **BS 6644** Clause 19.

The following notes are intended to give general guidance.

In all cases there **MUST** be provision for an adequate supply of air for both combustion and general ventilation, **in addition** to that required for any other appliance.

7.1 Air Supply by Natural Ventilation

The purpose provided space housing the boiler must have, or be provided with, permanent air vents communicating directly with the outside air, at high level and at low level. Where communication with the outside air is only possible by means of high level air vents, separate ducting down to floor level for the lower vents should be used. For an exposed boiler house, air vents should be fitted preferably on all four sides, but at least on two sides. Air vents should have negligible resistance and must not be sited in any position where they are likely to be easily blocked or flooded or in any position adjacent to an extraction system which is carrying flammable vapour. Grilles or louvres must be so designed that high velocity air streams do not occur within the space housing the boiler. The grilles shall have a total minimum free area as follows -

Low Level (inlet) -540cm² plus 4.5cm² per kilowatt in excess of 60 kW total rated input.

High Level (outlet) - 270cm² plus 2.25cm² per kilowatt in excess of 60kW total rated input.

The air supplied for boiler house ventilation shall not allow the boiler house temperature to exceed 25°C at floor level, 32°C at mid-level and 40°C at ceiling level during the heating season.

7.2 Air Supply by Mechanical Ventilation

The supply of air to a space housing the boiler by mechanical means should be by mechanical inlet with natural or mechanical extraction. Mechanical extract ventilation with natural inlet must not be used.

The requirements of air supply by mechanical ventilation are per 200kW module as follows: -

Inlet air - 771m³/h (minimum)
Extract air - 514m³/h

NOTE For mechanical ventilation systems an automatic control should be provided to cut off the gas supply to the boiler, in the event of failure of air flow in either inlet or extract fans.

8.0 WATER CIRCULATION SYSTEM

8.1 General

The boiler has a low water content and the requirements of minimum water flow are given in Section 8.8 and Figure No. 3. Recommendations for the water circulating system are given in **BS 6644** and **CP 342**.

The following notes are of particular importance.

In a combined central heating and hot water system, the hot water storage vessel must be of the indirect cylinder or calorifier type. The hot water storage vessel should be insulated preferably with not less than 75mm thick mineral fibre, or its thermal equivalent.

Circulating pipework not forming part of the useful heating surface should be insulated to help prevent heat loss and possible freezing, particularly where pipes run through roof spaces and ventilated cavities. Cisterns situated in areas that may be exposed to freezing conditions should also be insulated. Insulation exposed to the weather should be rendered

waterproof.

Drain valves must be located in accessible positions, which permit the draining of the whole system, including the boiler and hot water storage vessel.

8.2 Pressure Relief Valve (Safety Valve)

The most important single safety device fitted to a boiler is its safety valve and each boiler, or in the case of modular installations, each bank of boilers, must be fitted with a pressure relief valve to **BS 6759 Part 1 (ISO 4126)** and sized as in **BS 6644** (see below).

BS 6644 provides comprehensive information for the selection and location of safety valves and attention is drawn to the higher capacity requirements of safety valves for unvented hot water systems.

8.3 Open Vent Pipe and Cold Feed Pipe (See **BS 6644**).

Refer to Figure No. 2 for the open vent connection

BOILER	PRESSURE RELIEF VALVE (Open Vented Systems Only)	OPEN VENT AND COLD FEED PIPE	
		Open Vent Size	Cold Feed Size
Wessex-HE 200	19mm clear bore	38mm	32mm
Wessex-HE County	32mm clear bore	50mm	38mm

A vent pipe and cold feed pipe must be fitted to the water system between the boiler and the first isolating valve in the water system. The sizes of these pipes are shown below. The vent pipe must rise continually, must not be valved except by a design which when closed for maintenance, the boiler is open to atmosphere. The pipe shall be protected against freezing where this might occur.

8.4 Altitude Gauge (Water Pressure Gauge)

See Figure No. 2 for position of tapping. Every boiler or group of boilers should be provided with a gauge complete with isolating valve.

8.5 Thermometer (Temperature Gauge)

See Figure No. 2 for position of tapping.

A thermometer complete with pocket should be fitted in the pipework to indicate water flow temperature.

8.6 Drain Valves

See Figure No. 2 for position of tapping.

Each boiler must have a suitably sized drain valve fitted.

8.7 Circulating Pump

One or more circulating pumps will be required to circulate water around the boilers and heating system. Figure No. 3 shows the hydraulic resistance of the module. The pump should be sited to facilitate servicing. It is important to note that when Wessex boilers are used to replace boilers on an existing system, the pumps should be checked for performance against the new boiler waterside pressure drop to ensure that the minimum flow rate can be obtained. It is also important that the existing system be flushed through to remove any loose matter, which may have accumulated. If in any doubt regarding the cleanliness of the system, a coarse filter should be fitted in the return pipework to the boilers.

8.8 Minimum Water Flow Rates

The minimum water flow rate per module is shown in Figure No. 3 and should be maintained through each

boiler at all times when firing. If the water flow rate falls below the minimum, the boiler waterways might be subject to premature failure due to scale formation. Particular attention should be paid to the restriction of external flow circuits during periods of low heat demand.

8.9 Waterside Pressure Drop

The module waterside pressure drop is shown in Figure No. 3.

NOTE: If boilers are controlled via a time clock, a pump overrun (not HHL supply) should be fitted which must run for minimum of 3 minutes on shut-down of the boiler.

8.10 Control Schemes

8.10.1. Temperature Controls.

An adjustable control thermostat is fitted to each module and is set to operate within the range 65-90°C for standard applications.

If a higher water temperature is required (and providing sufficient head on the water system is available) the thermostat may be adjusted to operate in excess of 90°C.

For high temperature applications, a "special to contract" controls thermostat with a higher range may be required and it should be noted that on boilers applied to systems having flow temperatures in excess of 100°C, additional insulation should be applied to the front heat exchanger tube plates (Contact Hamworthy Heating for this special insulation kit).

A temperature limiter (hand reset limit thermostat) is also fitted to the module and is normally set at 100°C. A higher range limiter may be required for high temperature applications.

NOTE! The minimum difference between control thermostat and temperature limiter must not be less than 10°C. For adjustment see section 14.7.

8.10.2 Water Flow Controls

Any external mixing valves or similar controls should always ensure that the minimum water flow rate shown in Figure No. 3 is maintained. It is recommended that a water flow switch is fitted to the system. The switch should be connected such that the boiler cannot fire unless the water flow has been proved.

When multiple boilers are installed it is recommended that the water pipework is connected using the reverse flow principle to ensure equal flow through all

boilers

8.10.3 Frost Protection.

Consideration should be given to fitting a frost thermostat set at approximately 4°C.

8.11 Minimum Water System Pressure

To comply with Guidance Note PM5 from the Health and Safety Executive the minimum static water pressure at the highest point in the circulating system must be calculated as follows: -

If the boilers are to be installed as single units the minimum pressure must be equal to the gauge pressure equivalent to the saturated steam temperature obtained by adding 17°C to the required boiler flow temperature but never less than 2 m.

e.g. 1 Required Flow Temp. = 90°C
Safety Margin = 17°C

Equivalent Saturated Steam Temp = 107°C

From Steam Tables -
corresponding Gauge Pressure
= 0.3 bar
= 3.06 m head of water

If the boilers are to be installed in a modular formation the minimum pressure must be equal to the gauge pressure equivalent to the saturated steam temperature obtained by adding 17°C to the sum of the required mixed flow temperature and the temperature rise across the boilers.

e.g.2 Required mixed flow Temp = 82°C
Temp. Rise across boilers = 11°C
Safety Margin = 17°C

Equivalent Saturated Steam Temp = 110°C

From Steam Tables -
corresponding Gauge Pressure
= 0.42 bar
= 4.3 m head of water

e.g.3 Required mixed flow Temp. = 82°C
Temp. Rise across boilers
at minimum flow = 13°C
Safety Margin = 17°C

Equivalent Saturated Steam Temp = 112°C

From Steam Tables -
corresponding Gauge Pressure
= 0.57 bar
= 5.8 m head of water

8.12 Unvented Pressurised Systems

See Figure No. 2 for typical layout of a pressurised

(unvented) Hot Water System.

In order to correctly size a Pressurisation Unit for any Heating System certain parameters are required.

These are: -

- 1) Static height of highest component in system.
- 2) System volume - if not known a general rule of thumb of 10litres/kW installed boiler power can be used.
- 3) Maximum flow temperature, i.e. most systems run at 82°C.
- 4) Maximum system hot working pressure, generally given in bar gauge.

From the above information Hamworthy Heating can size the pressurisation unit and also the expansion vessel required.

Care must be taken in sizing expansion vessels to ensure maximum acceptance factors are not exceeded. Normally manufacturers of vessels impose a limit of 0.5. This value must not be exceeded at any time during the operation of the boiler: this includes the over pressure condition should a safety valve lift.

Consideration should also be given to sizing of the safety valve(s) in the system. See **BS 6759 Part 1 (ISO 4126)** and **BS 6644**.

See also **BS 6880 Part 1** for design considerations.

9.0 ELECTRICAL SUPPLY

See **BS 6644**.

WARNING: THIS APPLIANCE MUST BE EARTHED.

Wiring external to the boiler must be installed in accordance with the IEE Regulations and any local regulations, which apply. Wiring must be completed in heat resistant 3-core cable. (Size 1.0mm² CSA) Boilers are normally supplied for 230 volts. 50 Hz. Internal fuse rating of each module is 2 Amperes. External fuses should be 5 Amperes for all boilers.

The method of connection to the mains electricity supply must facilitate complete electrical isolation of the boiler module with a contact separation of at least 3mm in all poles. A mains isolator must be provided adjacent to the boiler in a readily accessible position. The supply should only serve the boiler. Further details regarding connection to the electricity supply are given in **BS 3456** (CEE 10 Part 1, CEE11 Part 1).

NOTE! Volt free contacts electrical supplies must also be isolatable when fitted (see note on fascia).

9.1 Mains Cable Connection

The path of the mains cable is shown in Figure No. 4. The length of the conductors between the cable anchorage and the terminals must be such that the current carrying wires become taut before the earth, should the cable slip out at the cord anchorage.

9.2 Boiler Wiring Diagram

The boiler-wiring diagram is shown in Figure No. 5. This wiring diagram is also fitted inside each boiler cover.

9.3 Indication Signals and Volt Free Contacts

If the boilers are to be wired to external indicator lights or alarms, it is preferred that each module should be fitted with a Volt Free Contact kit to divorce any external wiring from the internal control wiring.

The kit (P No. 563605145) may be fitted prior to delivery or on site, the mounting rail for the 3 relays being pre-installed on each module. 3 signals can be derived from the controls: -

- a) Normal run - derived from terminal 11 on main terminal rail.
- b) Overheat - derived from terminal 8 on main terminal rail.
- c) Lockout - derived from terminal 7 on main terminal rail.

Each of these 230V signals are wired to a separate relay coil and the volt free change over contacts can

be utilised to connect to the alarm/indicator system as required. A wiring diagram is supplied with the kit.

NOTE! These external circuits MUST be isolated before service or maintenance procedures are carried out.

10.0 INSTALLATION OF BOILERS

10.1 General

Each boiler is normally dispatched to site as a pre-assembled unit for floor mounting and should be stored in a weatherproof place prior to installation.

The boiler should be positioned to allow minimum clearance of 150mm to the rear, 400mm to each side, and 800mm to the front from adjacent walls or equipment to facilitate occasional inspection. Other installation dimensions are given in Figure Nos. 9 and 11.

The outer insulated casing should be fitted in accordance with the packed instructions after completing the gas and water pipework connections, but prior to connecting the boilers to the flue system. Care must be taken to prevent damage to the casings prior to contract completion.

NOTE! Fit the top insulation panel to the boiler prior to installing the flue.

10.2 Connection of Boilers to the Flue System

Notes on the recommendation for design of the flue system are given in Section 6.

No fixed draught diverter is fitted to the boiler nor is one required to be fitted to the flue system.

A flue socket is provided suitable for accepting standard twin wall flue pipe. Sealing of the flue to the socket should be made using a suitable caulking string and cold caulking compound.

Suitable means should be incorporated in the flue system adjacent to the boiler for removal of the boiler casing without dismantling the whole flue system.

NOTE! Fit top insulation panel before connecting the flue.

10.3 Gas Connection.

For design see Section 5.

Size and position of gas connection are shown in Figure Nos. 9 and 11. A filter mesh is fitted inside each main gas solenoid valve. Each module is fitted with an individual manual gas shut-off valve.

11.0 COMMISSIONING AND TESTING

11.1 Electrical Installation

For design see Section 9.

A suitably competent person must check wiring.

Normal supply required is 230V 50Hz single phase. An isolator correctly fused at 5 Amperes should be sited close to the boiler.

Any other interlocks i.e. pressurisation unit, BEM system should be wired in series with the remote stop/start loop (C5 & C6).

A schematic of the circuit is shown in Figure No. 5.

11.2 Gas Installation

For design see Section 5.

The whole of the gas installation including the meter, must be inspected and tested for soundness and purged, in accordance with the recommendations of **BS 6891, UP/1** or **UP/1A** as appropriate.

11.3 Water Circulation System

For design see Section 8.

NOTE! If a boiler is to be fitted into an old or existing pipework system it is advisable that this is chemically cleaned and thoroughly flushed prior to installation.

The whole of the system should be thoroughly flushed out with cold water without the pump in position. Ensure that all valves are open.

With the pump fitted, the system should be filled and air locks cleared. Vent the heat emitters and check for leaks.

11.4 Lighting the Boiler (Initial Commissioning)

Prior to delivery, all Wessex boilers are subject to a full sequence check and the differential pressure switch is adjusted to design settings (See Section 2.2). The intent therefore of the following initial commissioning procedure, is to check the correct functioning of the sequence system up to and including the establishment of the pilot flame, with the gas supply to the main burner isolated.

WARNING: Before attempting to light the boiler ensure that any personnel involved are aware of what action is about to be taken and begin by making the following checks: -

- i) Flueway passages and chimney are clear of obstructions.
- ii) Adequate ventilation exists in the boiler house,

reference Section 7.

iii) The system is fully charged with water, ready to receive heat, all necessary valves are open and the pump is running and circulating the water.

iv) The pipework and valve arrangement is installed to Hamworthy recommendations in such a way that adequate water flow rates will be present in accordance with Figure No. 3.

v) The gas supply pipework is clear of any loose matter, tested for soundness and purged.

Turn off the electrical supply to the boiler at the mains external isolator.

a) Remove the boiler front cover.

Disconnect the main gas valve wiring assembly plug, thus isolating the gas valves from the main burner controller.

Remove wire link on terminals C1 & C2 and insert a Multi-Meter set to read DC μ A.

Ensure main gas supply is turned **ON** at the boiler manual shut-off valve (Reference Figure No. 6.).

Remove the blank plug from the temperature limit reset panel on the fascia and push in the exposed reset button. Replace plug.

Set the control thermostat to the minimum setting (65°C) and switch on the electrical supply to the boiler at the external isolator, ensuring that all external controls are calling for heat (e.g. time clocks etc.).

b) Switch the boiler ON/OFF switch to 'ON'. Re-set the controller if at lockout, the cam timer will run to its normal start position. The fan will then start and the boiler will pre-purge for approximately 40 seconds.

c) Following this pre-purge period, an ignition spark will be generated and the pilot gas solenoid valve will energise to supply gas to the pilot burner.

d) After a few seconds, the spark will cease and the pilot flame-monitoring period will start. The pilot flame-proving signal should be 2.5 - 5.0 μ A.

e) On completion of the pilot proving period, the green 'normal firing' lamp will illuminate however, as the main gas solenoid valves have been disconnected, the controller will lockout after a maximum of 5 seconds. The amber 'lock-out' lamp on the controller will be lit and the green 'normal firing' lamp will be extinguished.

f) When the commissioning engineer is satisfied that the boiler has a stable pilot flame, switch off the boiler and re-connect the gas valve wiring plug assembly.

Main Burner Commissioning

Having established a satisfactory pilot flame and reconnected the supply to the main gas solenoid valve, the sequence described above will, after switching the boiler on, be repeated. Instead of the boiler going to lockout at the end of the safety time, the main gas valves will open. After approximately 5 seconds the pilot valve will be de-energised and the main flame should remain established under the control of the flame monitoring system. The main flame-proving signal should be 2.5-3.5 μ A.

Turn the boiler switch and mains electrical isolator 'OFF', remove the Multi-Meter, and reconnect link between terminals C1 & C2.

11.5 Gas Pressure Adjustment and Combustion Checks

11.5.1 Gas Pressure Adjustment (Natural Gas Only)

NOTE: - For adjustment relating to Propane firing, refer to Appendix 'A'.

After approximately 30 minutes of normal firing, connecting a differential manometer to test points A & B (either side of orifice) should check the gas pressure differential across the gas orifice (reference Figure No. 8). The pressure drop for Group H Natural Gas should be 2.6mbar and minor adjustments to the appliance governor may be necessary to correct for site gas pressure conditions. Two double solenoid valves arranged in parallel control the main gas. The left hand valve (when viewed from the front) acts when energised as a bypass without a governor (the governor is rendered inactive by the addition of a bypass screw, which must always remain in position and fully inserted). The right hand valve contains the appliance governor situated between the solenoids. Remove the metal screw cap to reveal the adjuster beneath.

NOTE! The above is a first order check, Final Setting must be made using a gas meter.

11.5.2 Combustion Checks

Details of the flue gas composition relating to Propane firing can be found in Appendix 'A'.

A flue gas sampling point is provided in the front boiler casing (see Figure No. 6). To check combustion take a flue gas sample from each module test point and for reference CO₂ measurements should be between 9 and 10% or 3.5 to 5.0% O₂. Normal CO levels should not exceed 200 ppm.

NOTE! All the above measurements refer to **dry flue gas** samples.

11.6 Temperature Limiter & Control Thermostats

11.6.1 Temperature Limiter

The temperature limiter is supplied factory set to 100° C, a temperature that is normally satisfactory for low-pressure hot water heating systems.

NOTE! For high temperature applications, it is essential that the water system static head or in the case of pressurised systems, the system pressure, is suitable for operation at elevated temperature, and attention is drawn to the specific requirements of **BS 6644** and the HSE Guidance Note: PM5 (Automatically controlled steam and hot water boilers). Refer also to section 8.11.

11.6.2 Control Thermostat Adjustment

Control thermostats are factory set to limit their adjustment to 90°C however, the thermostat may, under certain circumstances, be adjusted to operate in excess of this temperature.

The minimum difference between the control thermostat and temperature limiter **must not** be less than 10°C.

When all settings and readings are satisfactorily completed, tighten all test points and refit burner cover.

7 External Controls

The external controls used in typical boiler installations, for both vented and unvented systems, are shown in Figure No. 2. If different systems or controls are to be used and there are any doubts as to their suitability contact the manufacturer for advice.

8 Installation Noise

In order to avoid the possibility of noise from the installation, care should be taken to follow the manufacturer's instructions. Particular attention should be paid to minimum water flow rates. If acoustic insulation is added to the boiler, care must be taken not to impede combustion or ventilation airflow. If in doubt contact the manufacturer.

11.9 User's Instructions

Upon satisfactory completion of commissioning and testing, the commissioning engineer should hand the User's Instructions to the user or purchaser and explain the method of economic and efficient operation of the system. Ensure that the user or purchaser is fully conversant with lighting, shutdown and general operational and emergency procedures.

12.0 FAULT FINDING

The controller fitted to the Wessex-HE 200 boiler incorporates a rotating coloured disc fixed to the cam timer which provides information with regard to the position that has been achieved at any point in the sequence. This disc with the relevant sequence information is shown in Figure No. 7 and in general the fault can be located by observing the position at which the disc stopped rotating and the functions controlled to that point.

BOILER SEQUENCE CONTROLLER, OPERATION AND FAULT FINDING

12.1 Summary of Safety Features

1. Flame failure when running results in burner shutdown and lockout within 1 second.
2. Failure to establish and detect a flame during the light-up sequence results in burner shutdown and lockout within 2 - 5 seconds from the initial release of fuel.
3. Air supply failure at any time, results in burner shutdown and immediate lockout.
4. The differential pressure proving switch, is checked in both the "no air" and "air supply proved" positions.
5. Restoration of the power supply after an interruption, results in a full light-up sequence to safely restart the burner. Power failure after a lockout, will not interfere with this condition when the supply has been restored.
6. False flame signals at the start point and during pre-purge result in burner shutdown and lockout.
7. The light-up sequence can only commence providing the cam switches and relay contacts within the control box are at their correct relative positions, and continuity of the lockout relay circuit is proved.

12.2 Fault Finding - See Figure No. 7.

- 1. Fan will not start.** Coloured programme indicator stopped in white sector.
 - a) Check electrical supply is switched on.
 - b) Check that thermostat circuit is "calling for heat" and time switch circuit (if fitted) is made. A 230-Volt supply on the Programmer Terminal No.1 will determine this.
 - c) Check that the remote stop/start circuit loop across terminals C5 and C6 is made. Check Fascia mounted switch is in the 'ON' position.

2. Burner will not start. Synchronous motor runs, coloured programme indicator rotates but burner does not start.

Check differential pressure proving switch is in correct state i.e. "no air" position.

3. Fan starts but the boiler goes to lockout. Programme indicator stopped on red line in blue sector.

- a) Check differential pressure proving switch.
- b) Check that a load, e.g. pilot gas valve is connected to terminal C.
- c) Check continuity of pilot gas valve coil winding.
- d) Check for flame simulation or false flame signal.

4. Fan starts but the boiler goes to lockout. Coloured programme indicator stopped in blue sector.

- a) Check for combustion air supply failure.
- b) Check for flame simulation, if necessary, change control box.
- c) Check for continuity of pilot gas valve coil circuit.

5. Burner starts, flame established but control box goes to lockout. Coloured programme indicator stopped at end of first yellow sector/start of red sector or in red sector.

- a) Check that flame detection probe is in contact with the flame.
- b) Check that flame probe insulator is not cracked. A cracked insulator will be sufficient to give rise to an AC current leakage.
- c) Check that flame probe is not in contact with other metallic parts of the burner.
- d) Check gas supply turned on.

6. Burner starts, flame established but control box goes to lockout. Coloured programme indicator stopped at end of 2nd yellow/start of green sector.

This is an indication that the main flame has not been established or detected and lockout has resulted immediately the interrupted pilot has been switched off.

7. Burner starts, flame established but control box goes to lockout. Coloured programme indicator stopped in green sector.

Check that when main gas valve is energised, a change in combustion or flame characteristics has not

caused the flame to “lift off” the combustion head and hence allow the flame probe to lose contact with the flame.

8. Burner starts, runs but subsequently goes to lockout. Coloured programme indicator stopped at end of green and start of white sector.

- a) Check for interruption in gas supply.
- b) Check for failure of combustion air supply.
- c) Check flame probe position for proper contact with flame.
- d) Check flame probe insulator for soundness.
- e) If necessary, change control box.

12.3 Causes of Lockout

- 1. No Ignition.
- 2. Ignition not in correct place, check electrode settings and ceramic insulator for cracks or damage.
- 3. No gas supply.
- 4. Gas valve(s) not opening.
- 5. Failure of combustion air supply.
- 6. Incorrectly positioned flame probe, poor earth contact with flame, interference to flame signal from ignition spark.
- 7. Faulty control box.

13.0 SERVICING INSTRUCTIONS

13.1 General

Regular periodic servicing is recommended, preferably by a Hamworthy appointed person.

WARNING: ISOLATE THE ELECTRICAL SUPPLIES TO THE BOILER BEFORE SERVICING OR COMPONENT EXCHANGE PROCEDURE AND TURN OFF THE MANUAL GAS VALVE TO THE MODULE BEING SERVICED. VOLT FREE CONTACT ELECTRICAL SUPPLIES MUST ALSO BE ISOLATED IF FITTED.

13.2 Annual Service

NOTE: A competent plant maintenance engineer should check and ensure that the flue, its support and terminal, the ventilation to the boiler house, safety valve, drain, water filter if fitted, pressure gauge, etc. are in a serviceable and working condition and still comply with the relevant and aforementioned standards and Codes of Practice.

13.2.1 Remove controls cover by unscrewing the central 'Pozidrive' screw and releasing the top of the cover which hooks behind the closing plate around the top water connection (Wessex-HE 200 only). The cover is then drawn forward and removed.

The Wessex-HE County cover is removed in a similar way however the closing plates fitted around the water connections must first be removed.

At this stage in any servicing of the boiler, it may be advantageous, with regard to increasing the working space and preventing possible damage, to remove the boiler fascia plate. This can be achieved by locating and removing the 2 counter-sunk socket headed M4 screws situated below the fascia label. The fascia remains connected via the cables to the fuse, switch and neons, which are all removable spade connections. Note position and colours of cables before removal to facilitate reconnection.

NOTE: If the fascia is left loose but connected, care should be exercised to protect the cables rubbing on the controls bracket.

13.2.2 Remove fan/mixing chamber and controller assembly as described below: -

- a) Disconnect mains supply by pulling apart the interlocking terminal block, see Figure No. 4, releasing the cable clamps and disconnecting the differential pressure switch earth cable at the earth post. (If volt free contacts are fitted, locate the relays mounted on the side of the controls bracket and pull the white tabs beneath the relay bases downwards to disengage from the mounting rail).

- b) Disconnect leads to spark electrode and flame probe by pulling their connectors from the pilot assembly.
- c) Loosen and remove gas pipe from between the pilot burner and pilot solenoid valve. Blow through and clean.
- d) Unplug the Din Connector to the pilot solenoid valve by loosening securing screw.
- e) Un-plug the Main gas valves wiring assembly.
- f) Loosen and remove the two Bundy Tubes that connect the differential pressure switch to the fan/fan extension.
- g) Remove the clip and withdraw both thermostat bulbs from pocket.
- h) Unscrew the four M6 nuts securing the complete assembly to the front tube plate cover casting and withdraw the assembly from the module, lifting upwards to allow the fan housing to clear the gas inlet pipe.
- i) Remove stainless steel orifice plate/insert and its cork gaskets.
- j) The burner can now be withdrawn from inside the heat exchanger by first removing the M5 screw and washer, then tap lightly on the flange to loosen the burner. The centre cone can be gripped with pliers to facilitate withdrawal.

13.2.3 Clean the burner by gently brushing inner and outer surfaces, tap burner flange firmly downwards on a wooden block to eject particles of dust and debris. Check circular cork gasket for soundness and renew if necessary. Clean burner insert in a similar manner. Replace burner in module. (Closed end of burner must locate in recess in module rear tube plate, this will be indicated when the flanged end of the burner is flush and square with the front header casting.) Ensure the "Top" marking on the flange is correctly positioned. Check rectangular cork gaskets for soundness and renew if necessary. Position one gasket over studs and refit the burner insert. Complete by fitting second gasket.

13.2.4 The fan/mixing chamber and controller assembly may be removed to bench for cleaning:

- a) Un-plug fan wiring and remove fan casing/extension piece from fan and motor mounting plate by removing four 'Pozidrive' screws (one may already have been removed with cable clamp), holding fan motor and controls bracket and work loose taking care not to damage rubber gasket, and without putting any strain on cable connections or wiring loom.
- b) Gently brush fan blades if necessary to remove any dust accumulation.
- c) Blow through the differential pressure switch Bundy pipes to check that they are clear when they have been detached from the pressure switch, to prevent damage to the diaphragm.
- d) Gently brush both sides of swirler (located between fan discharge flange and extension

duct) to remove any dust accumulation.

NOTE! Exercise extreme caution when cleaning swirler as it must not be damaged or altered in any way. **Do not** attempt to remove it from its location.

13.2.5 Remove the pilot burner assembly by unscrewing the two M5 screws and withdrawing from heat exchanger. Check pilot assembly. If the spark electrode shows signs of oxidation or is bent, it should be renewed. Check spark gap is set to 2-3 mm. (See Figure No. 10). Check injector in brass fitting is clean. Check spiral stabiliser for wear and renew complete unit if necessary.

13.2.6 Check flame probe for signs of oxidation or bending. Renew if required. Length of metal rod should be 98mm minimum. Refit pilot assembly.

13.2.7 Re-assemble fan/mixing chamber and controller assembly to boiler in reverse procedure to that given in paragraph 13.2.2. Use colour code shown on wiring diagram (Figure No. 5) to facilitate reconnection of electrical leads.

13.2.8 Ensure module manual gas valve is off, check the programmed sequence as described in paragraph 11.4/11.5 on initial commissioning in Commissioning and Testing section. Test all gas joints broken or disturbed for soundness before firing.

13.2.9 Remove the two filter pads from the burner tray and the front of the module controls cover. Remove dust by shaking or washing in soapy water, rinsing and drying. If the contaminants cannot be substantially removed - discard and fit new filters.

13.2.10 Carry out combustion check by testing the flue gas CO₂ and CO levels; typical values are given in paragraph 11.5.2. Replace module cover, tighten retaining screw and fit closing plate if part of HE County model.

13.3 Two Year Service

- a) **NOTE:** It is advisable to have at hand a tube of silicone rubber sealant or self adhesive silicon rubber strip in addition to other usual gasket materials.

13.3.1 Repeat annual service as describe in paragraphs 13.2.1 to 13.2.6 inclusive, but do not reassemble any items to the boiler.

13.3.2

- a) For the Wessex-HE 200 remove and retain the 6 M5 'Pozidrive' screws retaining the boiler insulation panels, taking care to note the order of re-assembly. (The HE County panels are not screwed but are retained on brackets and can be lifted off). Lift the top insulation panel clear of the boiler and then

remove each of the four individual side panels.

b) Undo all the M5 screws retaining opposite stainless casing side panels and remove by pulling out at the top and then lifting; if caution is exercised the silicone rubber seal will come away intact on each side panel and can be re-used.

c) Unhook both stainless coil spring baffle retainers and remove. Also remove the 16 stainless steel baffle plates. Wire brush both sides of the baffles to remove any deposits.

d) Thoroughly brush the exposed finned copper tubes until clean. (The tube bank may be gently hosed down with clean water to remove debris providing the burner is removed). If compressed air is available, use to remove debris dry or excess water.

e) De-sludge the floor of the casing and ensure the drain is clear.

13.3.3 If necessary repair the silicone rubber seal around edges of side panels with new liquid sealant., allow 20 minutes for partial cure, or replace with silicon rubber strip.

13.3.4 Replace one coil spring baffle retainer around tube bank and slip in baffles one at a time. When all the baffles are repositioned replace the second retainer spring and locate between tabs on baffles, ensure first retainer is similarly located. Now lightly smear grease over side sealing faces of casing if using liquid sealant gasket.

13.3.5 Replace side panels carefully to avoid damaging repaired seal etc. and tighten screws. Clean off any excess liquid rubber that may squeeze out.

13.3.6 Continue with re-assembly in accordance with procedure for annual service: paragraphs 13.2.7 to 13.2.10.

13.4 Four Year Service

13.4.1 Either the heat exchanger module may be descaled in situ*:

Repeat two-year services as described in paragraphs 13.3 to 13.3.5 inclusive then:

13.4.2 Isolate the boiler from the main system flow and return pipes and circulate a chemical descaling solution through the heat exchanger, preferably using a pumped recirculating system. This is best carried out by specialists using suitable chemicals. Follow the chemical manufacturer's recommendations and instructions regarding method, solution strength and safety and handling precautions.

Reconnect boiler to pipework system after cleaning up flanges and renewing gaskets.

NOTE: Fit flange bolts so that nuts are uppermost on flow connection, and underneath on return connection. This is important to avoid controls cover fouling bolts.

Now proceed to paragraphs 13.4.12 and 13.4.13.

* Or alternatively the heat exchanger module may be removed for descaling:

13.4.3 Carry out annual service as previously described in paragraphs 13.2.1 to 13.2.6 inclusive, do not re-assemble any items to boiler.

13.4.4

a) Release 25mm gas union connecting manual shut-off valve to boiler pipework.

b) Undo the M8 nut and bolt clamping the vertical gas feed pipe. Undo both M8 set screws retaining gas controls assembly to water return elbow. Remove gas control assembly.

13.4.5

a) Isolate the boiler from the main system flow and return pipes and drain boiler. (It contains approximately 20 litres).

b) Remove filter tray assembly by slackening the six (three each side) M5 pan head screws and lift off at the keyhole slots.

13.4.6 Either:

a) Remove the six M10 nuts holding the heat exchanger module to the casing, and carefully withdraw the module from its casing by sliding it out on its internal runners. The module is heavy (137kg) and will require frontal support as soon as the front flange clears the studs. Otherwise tube bank damage will result. Also support the rear of the module as it emerges from the casing.

Alternative to a) above if space permits:

b) Disconnect boiler casing from flue duct and remove water flow and return pipework local to boiler front including elbows up to front header casting. Undo four of the six M10 nuts (front header to casing) leaving the two outer nuts in place (those on horizontal centre line of module). Tip casing forward onto front header casting using timber or similar to protect studs etc. and to shore up.

Undo the remaining two M10 nuts and gently lift casing from the module.

Return casing to normal position for cleaning.

13.4.7 Remove module baffles by unhooking the stainless steel retaining springs. Brush the baffles and tube bank assembly and continue service in accordance with paragraphs 13.3.2 (c), (d) and (e). (Two Year Service).

13.4.8

a) Remove the 12 x M12 bolts securing the front header plate to the front tube plate and separate the plates.

b) Remove the 18 x M12 bolts securing the rear cover plate to the rear tube plate and separate the plates.

c) Clean and descale the internal surfaces of the tubes and also the waterways in the tube plates and covers. Chemical descaling is preferred for the tube bank assembly, using suitable proprietary solutions.

Follow chemical manufacturer's instructions for solution strength, method of application, safety and handling precautions.

13.4.9 Clean up mating surfaces and re-assemble covers to tube plates with new gaskets lightly greased before assembly. Torque the M12 bolts down evenly to 81Nm.

13.4.10

a) Re-assemble baffles to module etc. in accordance with procedure in paragraph 13.3.4.

b) Renew ceramic rope seal or silicon rubber self-adhesive strip and replace module in casing by reverse of either method (a) or (b) described in paragraph 13.4.6.

c) If necessary replace boiler "in line" with its associated pipework and reconnect flow and return connections and flue duct, clean up flanges and renew gaskets.

NOTE: Fit flange bolts to flow and return elbows so that nuts are uppermost on flow connection, and underneath on return connection. This is important to avoid controls cover fouling bolts.

13.4.11

a) Replace gas controls assembly, ensuring correct orientation.

b) Reconnect main gas union to manual shut-off valve.

13.4.12 Continue with re-assembly in accordance with procedure for annual service: paragraphs 13.2.7 to 13.2.10.

14.0 REPLACEMENT OF FAILED COMPONENTS

There are a number of components listed below which can be replaced simply and quickly by following the given procedure. In each case carrying out the appropriate part of the commissioning procedure must check the operation of each replaced component. See section 11.0.

NOTE: ISOLATE ELECTRICAL SUPPLY TO THE BOILER AND TURN OFF THE GAS SUPPLY BEFORE REMOVING CONTROLS COVER AND COMMENCING ANY SERVICING OR COMPONENT EXCHANGE PROCEDURE. ALWAYS ENSURE THAT ONLY GENUINE SPARE COMPONENTS ARE USED AND ELECTRICAL CONNECTIONS CORRECTLY MADE.

14.1 Pilot Burner Assembly - HHL Part No. 563801004.

The pilot burner is situated on the horizontal centre line to the right of the fan extension duct, screwed to the front header casting.

Pull off the HT and flame probe caps, loosen nuts securing pilot gas supply pipe and remove; remove the two M5 screws and withdraw the assembly.

Renew insulated spark and probe electrodes as required -

HHL Part Nos.

Spark Electrode 333801440
Flame Probe 533805006

Generally clean up pilot assembly removing any loose sooty deposits or oxidation and replacing any damaged parts, see Figure No. 10 (Assembly Drawing).

Check pilot assembly. If either electrode shows signs of oxidation or is bent it should be renewed.

Check spark gap is set at 2 to 3mm. Adjust if necessary. If lack of gas flow is suspected, check the pilot filter by removing the brass pilot gas supply fitting screwed into the left hand side of the main gas inlet manifold. The fitting contains a secured foam filter pad. Blow through carefully in reverse gas direction to clear any debris or replace fitting complete with new filter ensuring joint is gas tight.

Replace pilot assembly in reverse order.

14.2 Fan Motor Renewal - HHL Part No. 533901295.

First check that the replacement motor assembly has been supplied with the motor plate and 5-pin Wieland plug fitted, and that there is a replacement rubber

gasket packed loose.

Un-plug fan assembly from main controller wiring loom.

Remove the four M5 'PoziDrive' screws holding the controls bracket and fan motor plate to the fan casing. Place the controls bracket to one side taking care not to stretch or pull any cables or capillaries etc.

Withdraw the fan, also removing the existing rubber gasket. Slacken the impeller retaining grub screw and remove the impeller from the motor shaft.

Select the new motor that is supplied complete with new motor mounting plate and check plate is secure and rubber grommet is in position between motor and plate around the shaft.

Position the impeller on shaft to give a 6mm gap between motor plate and impeller back plate at the rim of the latter. Tighten the retaining grub screw onto the flat surface provided on the motor shaft.

Rebuild the assembly in reverse order to remainder of removal procedure, using the wiring diagram on the controls cover to assist with wiring connections to the plug, if required. **NOTE!** A 5-pin plug and socket arrangement is used. For wiring, see diagram supplied with replacement motor.

Always replace the fan casing rubber gasket with the new one supplied with the replacement fan motor.

14.3 Pilot Solenoid Valve Renewal (Coil only) - HHL Part No. 533903031

It is likely that the main cause of gas valve failure will be due to coil winding failure either open or short circuit. In such an event it is possible to replace the coil only.

Disconnect the Din Plug from the valve coil by loosening the securing screw.

Unscrew the nut on top of the valve and lift coil from valve stem. Replace with new coil in correct orientation. Refit and tighten the top nut and Din Plug.

14.4 Main Solenoid Valves (Natural Gas Only)

NOTE: - If one of the main solenoid valves is to be replaced, the correct model for the gas being fired **MUST** be fitted.

NOTE: -For Propane firing refer to Appendix 'A'.

Main gas valve HHL Part No. 533903021
By-pass gas valve HHL Part No.533903025

NOTE! Only gas valves with an identical Type No. may be used for replacement purposes. Please

contact Hamworthy Heating Spares Dept. for further information.

a) Remove the gas valve wiring plugs at the valve to be removed by loosening plug-retaining screws.

b) Loosen the 4 cap head screws securing the outlet (front) manifold to the gas valve, which is not to be changed and remove the 8 cap head screws securing the inlet and outlet of the valve to be changed.

c) The pipework should spring sufficiently for the valve to be removed together with its sealing 'o' ring at either end.

d) Select new valve and check it is identical to that being replaced and it is in the correct orientation (check arrow on valve). It is advisable to fit new 'o' ring seals at either end. Re-align the new valve with the manifolds and replace and tighten the cap head screws. Ensure 'o' ring seals remain in correct position. Re-tighten the 4 cap head screws on second valve also ensuring 'o' ring seal is correctly located.

e) Re-connect the gas valve wiring plugs at the valve and secure.

This method can also be employed to check the inlet filters on each valve if lack of gas flow is suspected. On completion, check all disturbed joints for gas leakage and re-commission the boiler as detailed in sections 11.4 and 11.5.

14.5 Differential Pressure Switch Renewal - HHL Part No. 533901394

The differential pressure switch is located on the left-hand side of the fan casing and attached to the gas feed pipe fabrication.

Remove cover by releasing the 2 screws. Disconnect wires from terminals and remove cable by releasing gland. Release bundy tube nuts at elbow and straight fitting on switch. Remove fittings and refit to new switch in the appropriate positions using suitable sealant.

NOTE! When fittings are removed from switch ensure that holes are clear of any obstruction and jointing compound before re-fitting to new switch.

Fit new switch in reverse order ensuring the appropriate joints are gas tight and connect wiring through gland as indicated:

- a) White/Red wire to terminal marked "2" (NO).
- a) White wire to terminal marked "3" (COM).
- c) Green/Yellow wire to earthing terminal.

Tighten cable gland.

Check switch is set to 1.2 mbar and replace cover plate. Start the boiler several times to check for reliability.

14.6 Control Thermostat Renewal - HHL Part No. 533901178 or 339009345

Alternative thermostat manufacturers may be used in the Wessex boiler controls assembly. However, the fitting and wire spade connections are physically identical. The terminal identification may well be different from that shown on the wiring diagram. Please refer to diagram included on the thermostat to ensure correct connections are made and correct operation is obtained.

To replace the thermostat the following procedure must be followed. **NOTE!** Record existing temperature setting of thermostat for reference before removal.

Remove thermostat capillary retaining clip at pocket and withdraw the bulb from the pocket in the flow elbow. Remove the PINK and RED/BLUE leads at the "push-on" terminals on the thermostat body. Pull off the control knob and remove the spring and bezel. The thermostat is retained to the support bracket by two M3 screws, one of which is a pillar type and forms the control knob stop. Take care to note the relative position of the two screws before removing them (i.e. the lower screw has a pillar head), together with the thermostat body.

Re-assemble the new thermostat in reverse procedure ensuring that the leads connect the thermostat in the normally closed position. (Identified as contacts 1 and 2 or C and NC on the thermostat body.) Run the boiler and turn the thermostat up and down to check for correct operation during the warm up period.

14.7 Temperature Limiter Renewal - HHL Part No.533901179 or 339011044

Firstly remove the fascia as described in 13.2.1. Remove sequence control box by loosening central screw and pulling out.

Remove thermostat capillary retaining clip at pocket and withdraw the bulb from the pocket in the flow elbow. Remove the YELLOW, GREY and RED/BLUE leads at the "push-on" terminals on the limiter's body. Undo the bulkhead nut and withdraw the limiter.

Fit the new temperature limiter in reverse order ensuring that the YELLOW lead connects to common, the RED/BLUE lead connects the normally closed position and GREY the normally open position.

NOTE: For adjustment of the temperature limiter operating range, refer to section 8.10.1 and follow this procedure. Adjustment can be made with screwdriver when limiter is removed.

14.8 Sequence Controller Renewal - HHL Part No. 747246236

The sequence controller can be removed complete. Firstly remove the fascia as described in 13.2.1. Unscrew the cheese head screw retaining the controller to its terminal wiring base. Pull the controller firmly from its base, there will be some resistance due to the "push-in" terminal connections. Locate new controller correctly to base and push firmly home, tighten retaining screw.

14.9 Neon Indicators and On/Off Switch Renewal

Item	HHL Part No.
Green neon lamp	747436456
Red neon lamp	747436449
On/off rocker switch	339006648

Pull off the electrical leads to the appropriate item spade connectors. Release switch or lamp from mounting fascia by pressing in the plastic retaining lugs at the top and bottom. Pull components out frontwards. Push in new component until lugs lock in position and reconnect leads. Consult wiring diagram on controls cover or Figure No. 5 if in doubt regarding reconnection.

14.10 Ignition Spark Generator - HHL Part No. 747217120

The ignition spark generator is located behind the sequence controller. Firstly remove the fascia as described in 13.2.1. Release the screw retaining the sequence controller and pull the top clear of the base-plate to expose the terminal rails. Pull off HT cap from ignition electrode and unscrew the clip inside the cap and pull out the lead (use 'Pozidrive' No. 2 point in the clip). Disconnect wiring from base-plate at terminals A, 8 and E. Release two screws securing base plate and transformer to controls bracket, remove transformer.

Re-assemble components in reverse order making sure that the transformer is earthed at the earthing terminal.

Figure No. 2 - Typical Boiler Installation

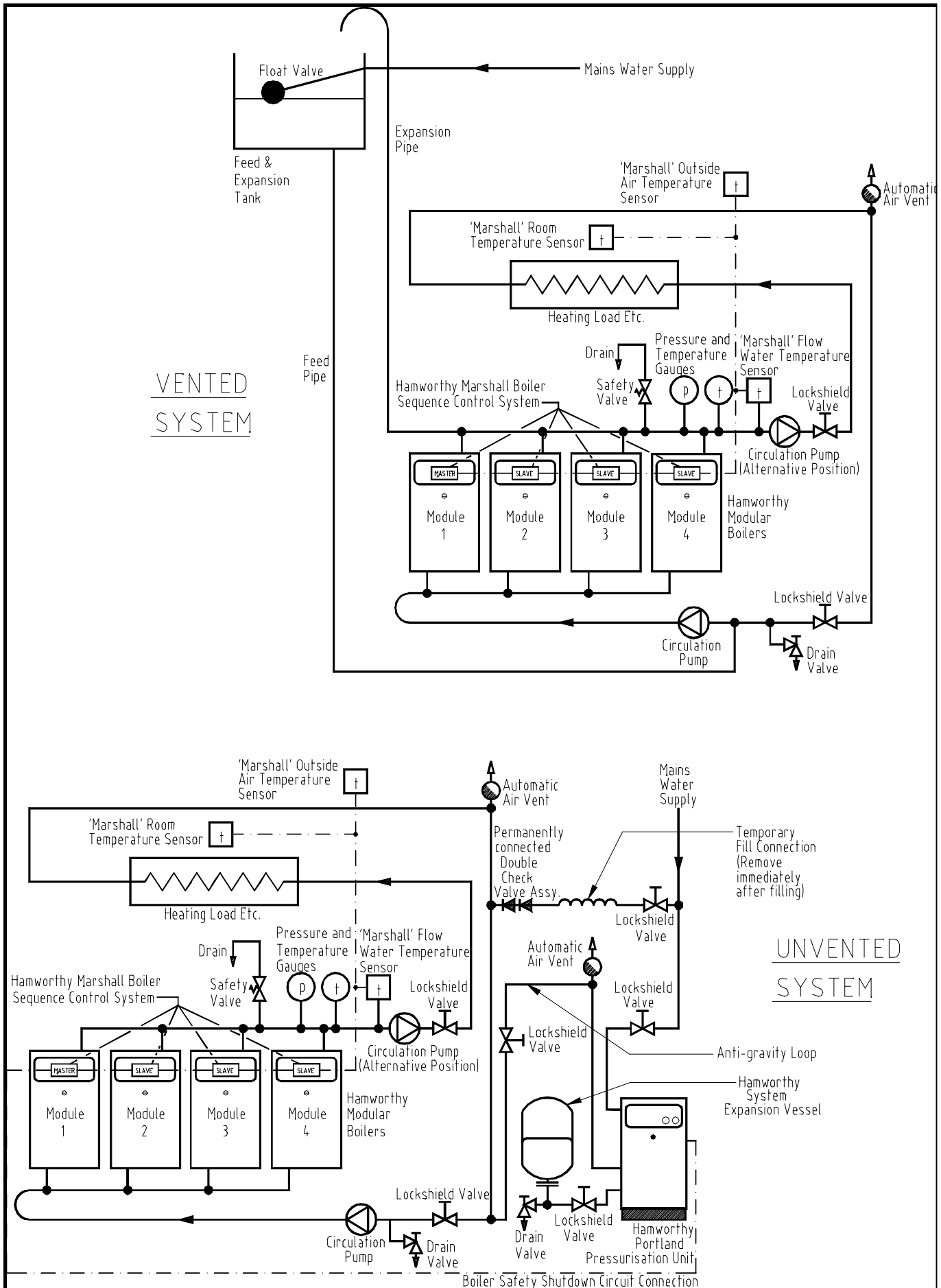

Figure No. 3 – Wessex-HE 200 Module Waterside Pressure Loss

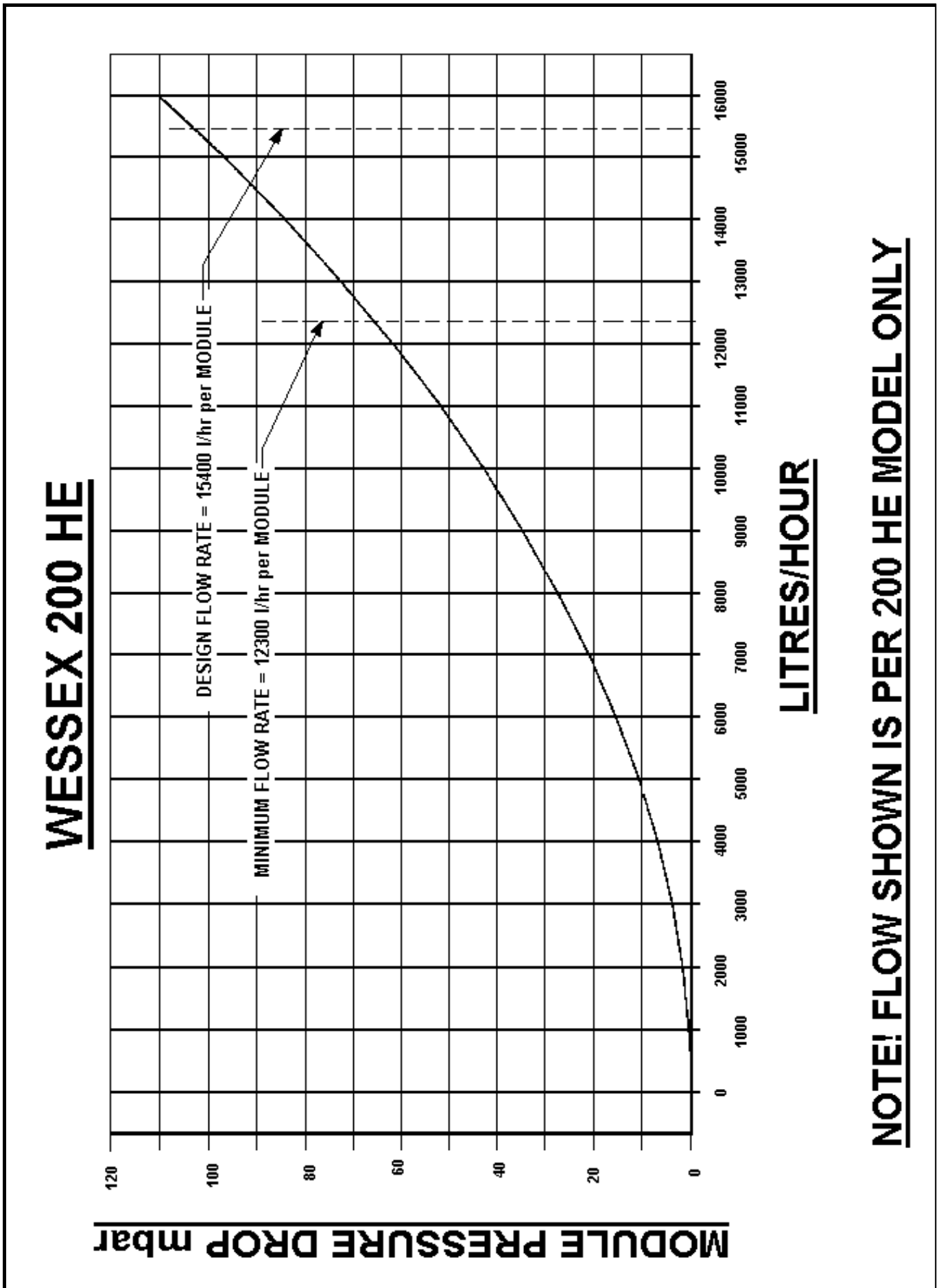

Figure No. 4 - Terminal and Mains Cable Layout

KEY: -

I - BOILER CASING

II - CABLE CLAMP

III - SUGGESTED CABLE ROUTE

IV - CABLE GUIDE

V - TERMINAL BLOCK

VI - CONTROL THERMOSTAT

VII - WIRING DETAIL

VIII - EARTH TERMINAL

IX - EMC FILTER

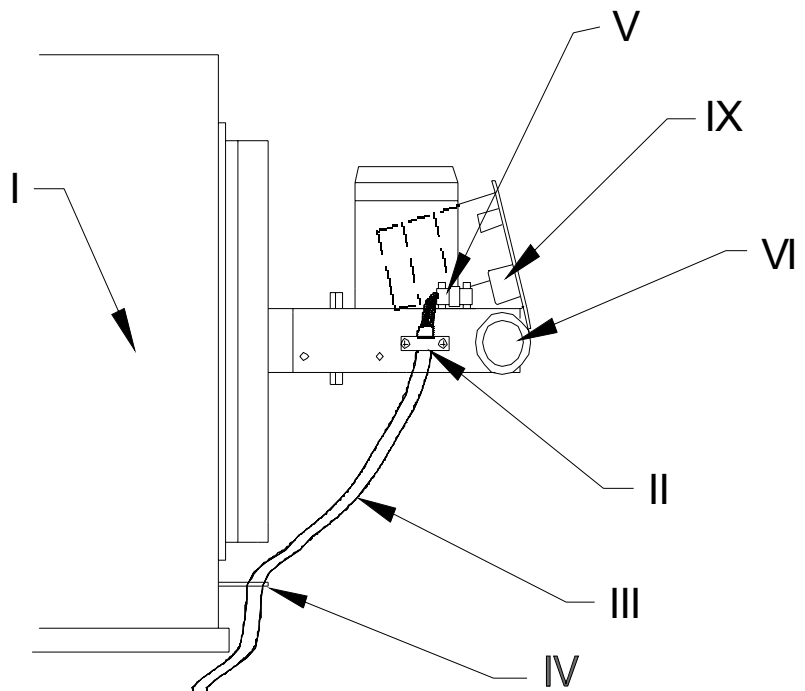
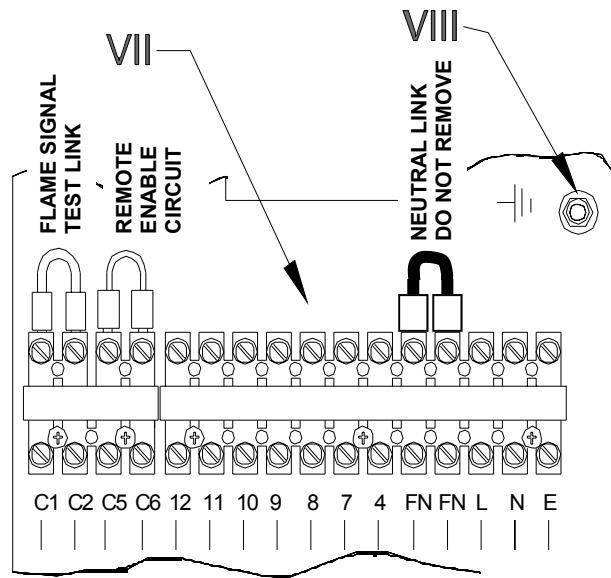

Figure No. 5 - Wiring Diagram – Wessex-HE 200

WESSEX 200 HE SCHEMATIC WIRING DIAGRAM

Colour Code:-

- Bk - Black
- Bl - Blue
- Br - Brown
- Gy - Grey
- Pk - Pink
- Rd - Red
- Vt - Violet
- Wh - White
- Ye - Yellow
- Gr/Ye - Green/Yellow
- Rd/Bl - Red/Blue
- Wh/Rd - White/Red
- Wh/Bk - White/Black

S1	S2
9	C
8	N
7	N
6	N
5	E
4	E
3	
2	B
1	A

KEY:

- CONTROL TERMINALS (TYPICAL)
- BOILER TERMINALS (TYPICAL)
- GAS VALVE ETC.
- MOTOR CAPACITOR (2uF)
- IN LINE CONNECTOR

- | | | | |
|------|-----------------------------------|-------|--------------------------------|
| I | Power 'ON' Lamp (Red) | XII | Gas Valve 1 |
| II | Temperature Limiter | XIII | Gas Valve 2 |
| III | Control Thermostat | XIV | Pilot Gas Valve |
| IV | EMC Filter | XV | High Temperature - 230V Signal |
| V | 2A Fuse | XVI | Remote Start/Stop Link |
| VI | Sequence Controller (inc. Layout) | XVII | Fan Motor |
| VII | Gas Pressure Switch, if fitted | XVIII | Boiler 'ON/OFF' Switch |
| VIII | Probe Test Link Terminal | XIX | Lockout - 230V Signal |
| IX | Flame Probe | XX | Boiler 'ON' Indicator (Green) |
| X | Motor Capacitor | XXI | Ignition Transformer |
| XI | Air Pressure Switch | | |

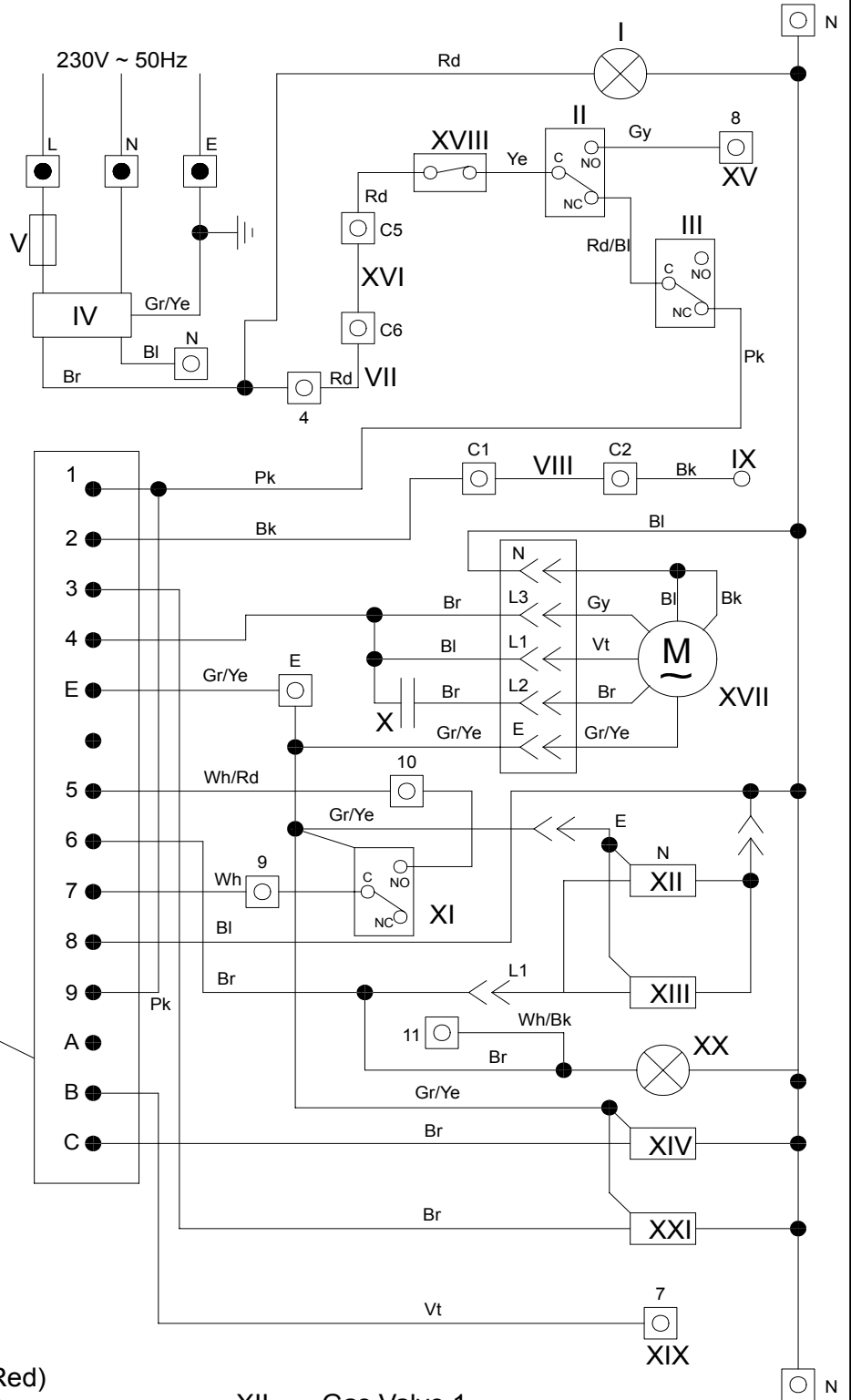

500011109/E

Figure No. 6 – Wessex-HE 200 Module (Natural Gas)

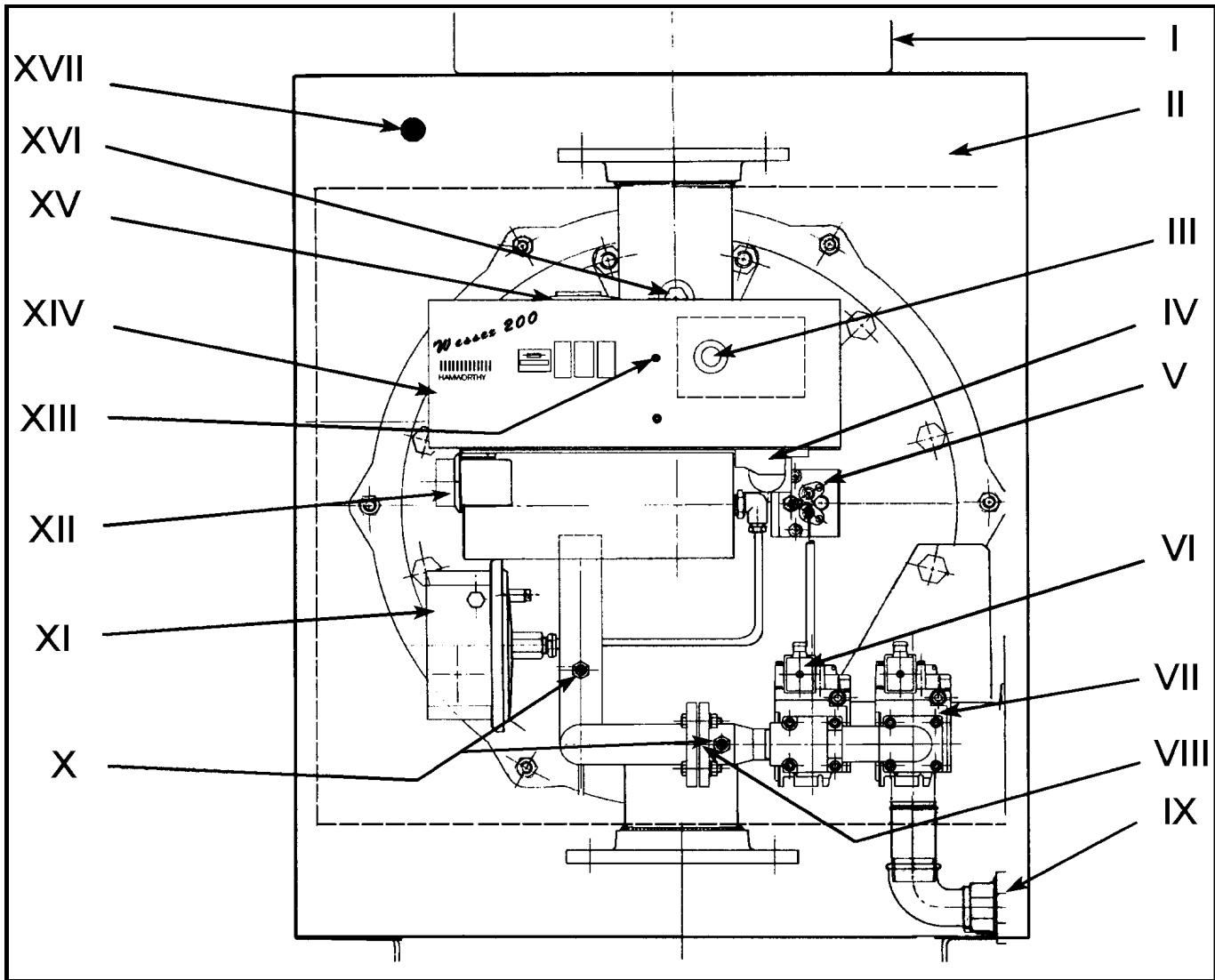

KEY: -

- I - BOILER FLUE CONNECTION
- II - BOILER CASING
- III - PROGRAMMER
- IV - GAS VALVE WIRING PLUG
- V - PILOT BURNER
- VI - BY PASS GAS VALVE
- VII - MAIN GAS VALVE
- VIII - GAS ORIFICE
- IX - Rp1 GAS CONNECTION
- X - PRESSURE TEST POINTS
- XI - DIFFERENTIAL PRESSURE SWITCH
- XII - CONTROL THERMOSTAT
- XIII - TEMPERATURE LIMITER
- XIV - FASCIA ASSEMBLY
- XV - FAN MOTOR
- XVI - THERMOSTAT POCKET
- XVII - FLUE GAS SAMPLING POINT

Figure No. 7 - Sequence Controller Indicator Disc.

KEY: -

- Position A: - Pre-Purge Starts
Approx. Time = 45 Seconds. **WHITE/BLUE**
- Position B: - Differential Pressure Proving
Switch Made - Red Line. **BLUE**
- Position C: - Ignition Circuit 'On'
and Pilot Gas valve open. **BLUE/YELLOW**
- Position D: - Ignition Circuit 'Off'
Pilot Proving Period Starts. **YELLOW/RED**
- Position E: - Main Gas Valve opens. **RED/YELLOW**
- Position F: - Pilot Gas Valve
Closes. **YELLOW/GREEN**
- Position G: - Burner Normal Run. **GREEN/WHITE**
- Position H: - Proving of
No Air Position. **WHITE**

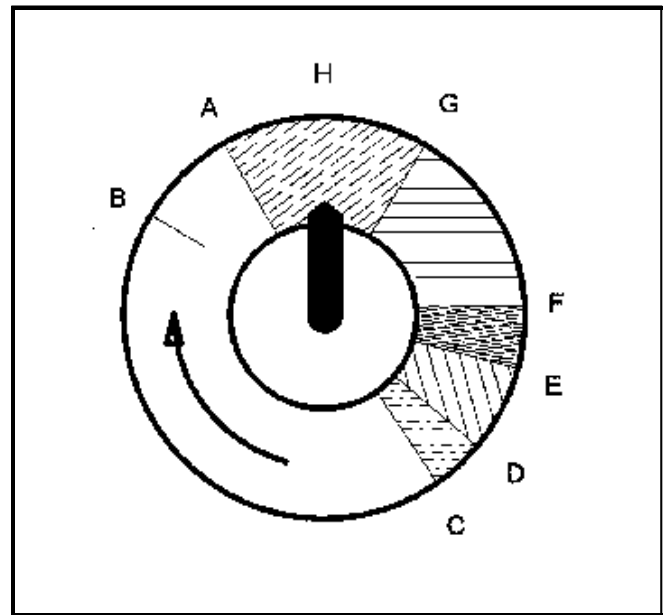
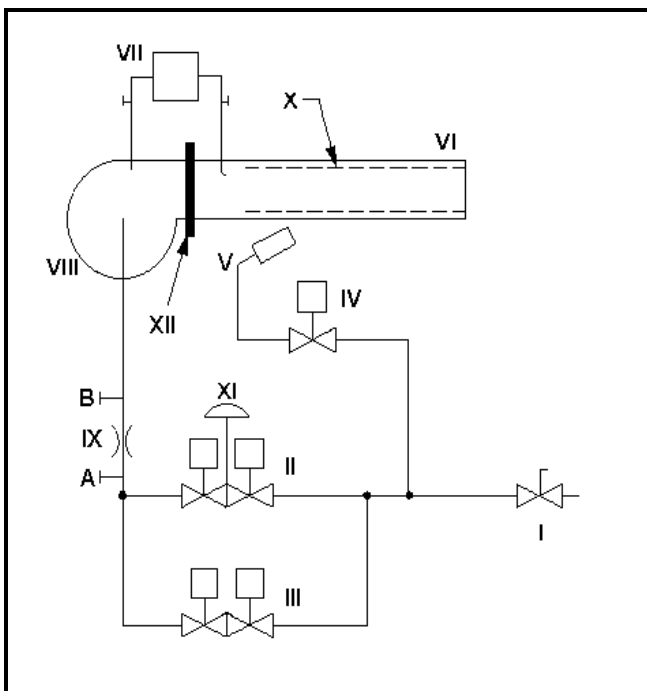

Figure No. 8 - Burner Flow System Schematic (Natural Gas)



KEY: -

- I - Manual Gas Valve (Ball Type)**
- II - Control Gas Valve**
- III - By - Pass Gas valve**
- IV - Pilot Gas Valve**
- V - Pilot Burner**
- VI - Main Burner**
- VII - Differential Pressure Switch**
- VIII - Burner Fan**
- IX - Gas Orifice**
- X - Burner Insert**
- XI - Governor**
- XII - Air Swirler**

Figure No. 9 - Boiler Dimensions & Clearances

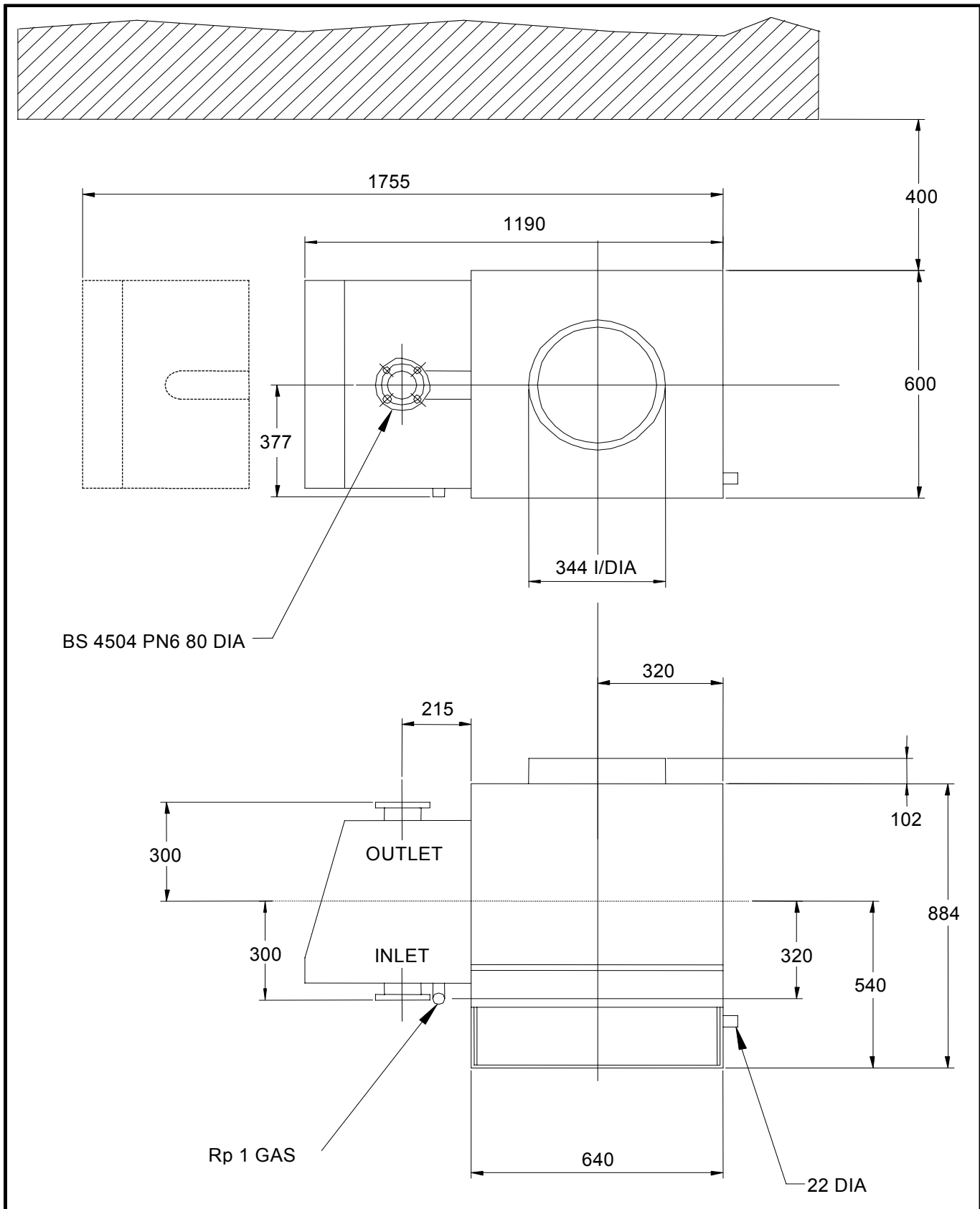
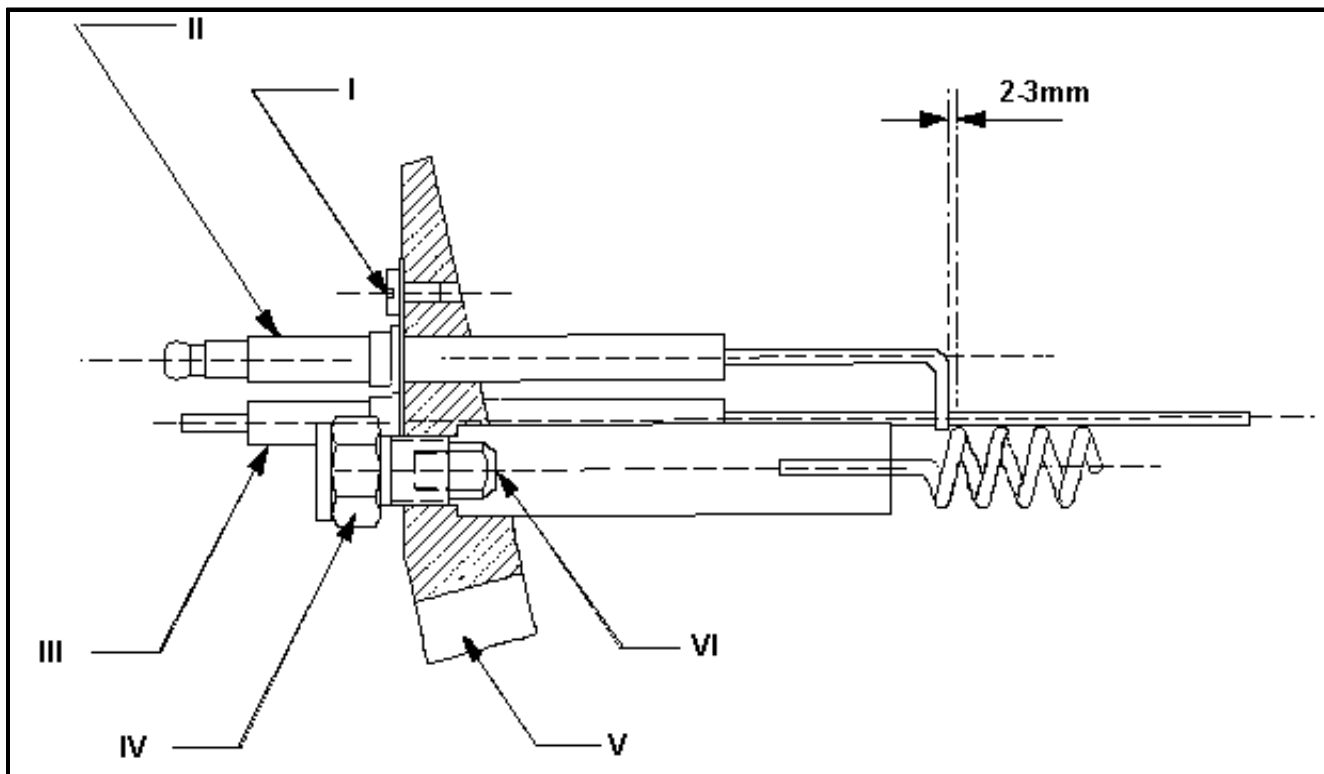

Figure No. 10 - Wessex Pilot Burner Assembly



Key: -

- I - ELECTRODE/PROBE SCREW
748132146
- II - SPARK ELECTRODE
333801440
- III - FLAME PROBE
533805006
- IV - JET CARRIER
333310871
- V - IGNITER BLOCK
333311465
- VI - PILOT INJECTOR
331101959 (marked 200) for Natural Gas firing
532902043 (marked 35) for Propane firing

Figure 11 - Arrangement Drawing – Wessex-HE County

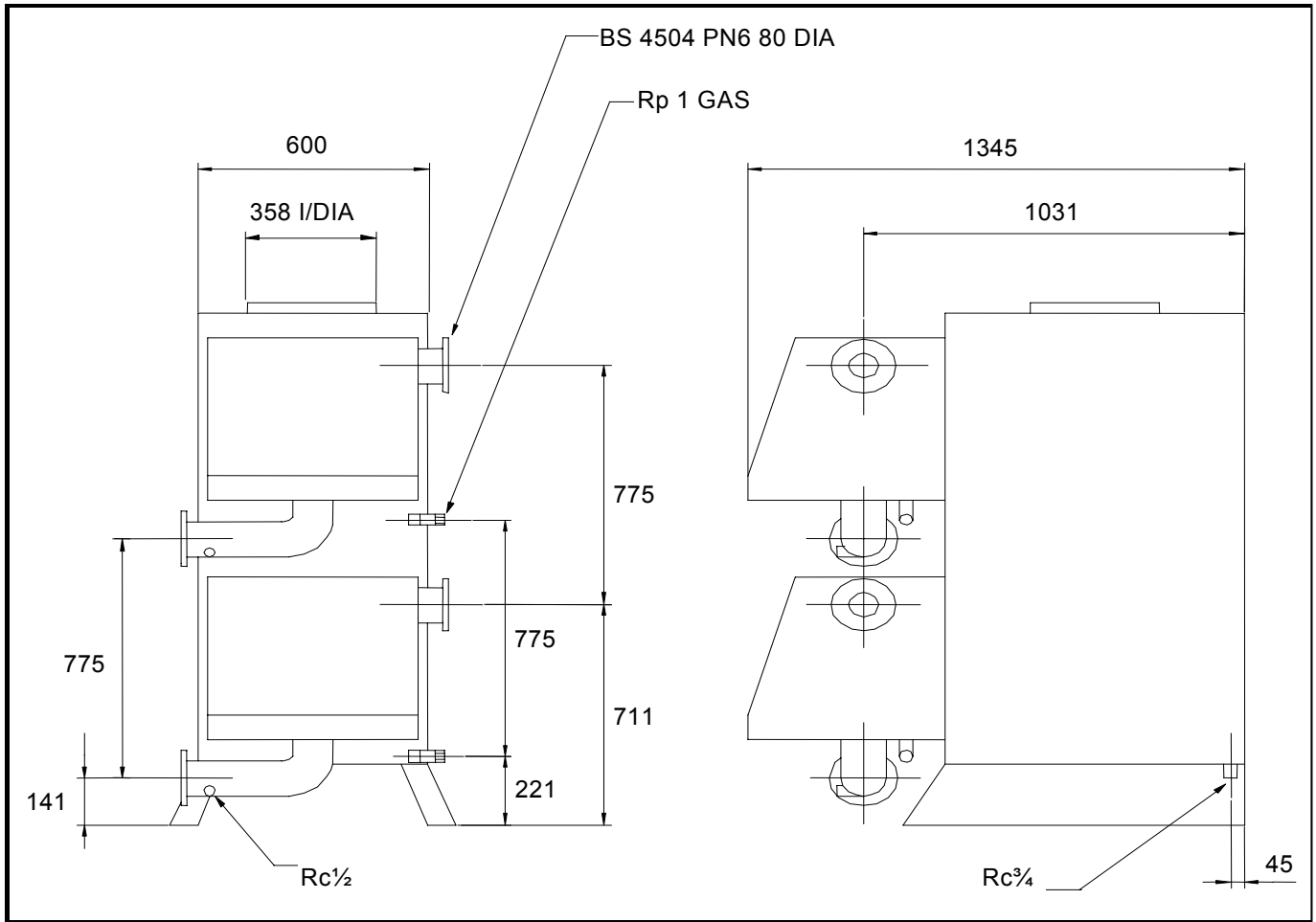

**APPENDIX 'A' TO INSTALLER'S GUIDE FOR
WESSEX-HE 200 BOILER RANGE**

INFORMATION RELATING TO PROPANE FIRING

NOTE!

LPG FUELS - IT IS STRONGLY RECOMMENDED THAT, ON LPG INSTALLATIONS, GAS DETECTION EQUIPMENT BE FITTED. THIS EQUIPMENT SHOULD BE POSITIONED NEAR THE BOILER AND AT LOW LEVEL. IT IS ALSO IMPORTANT THAT THE SPACE HOUSING THE BOILER IS ADEQUATELY VENTILATED AT HIGH AND LOW LEVEL. REFER TO MAIN INSTALLER'S GUIDE.

1.0 INTRODUCTION

The operation of the Wessex-HE 200 range of boilers on LPG - Propane (3rd family)_{I_{3P}} gas is similar to that on Natural Gas (2nd family)_{I_{2H}} and the design and installation details described in the main body of the Installer's Guide should be followed. There are, however, differences in the construction and setting of the Propane fired boiler module which are as follows: -

- a) The pilot injector marked 200 for Natural Gas is replaced with a smaller injector marked 35 for Propane.
- b) The main gas orifice (located and attached in the first flange at the control valves common outlet - see Figure No. 6) sized at 18mm DIA for Natural Gas is supplemented by the addition of a smaller orifice sized at 10mm DIA for Propane (located between the flanges).
- c) The bypass gas solenoid valve with an inactive

governor fitted for Natural Gas is replaced with a gas solenoid valve with active governor for Propane. Both main valves are therefore identical when firing Propane and also identical to the active governor valve used on Natural Gas with no change of spring.

- d) The nominal gas inlet pressure of the Propane should be 37mbar.
- e) The gas orifice pressure drop set at 2.6mbar during commissioning for Natural Gas is increased to 17.5mbar for Propane.
- f) Relevant labels are replaced to indicate the appropriate gas for which the boiler module is set up to fire.

The following tables, paragraphs and figures, using the same numbering system as the main Installer's Guide, highlight the different values and procedures to be used when firing Propane and should be used in conjunction with the main Installer's Guide.

2.2 Technical Data Table (Propane)

GENERAL DATA Wessex-HE 200 Series	BOILER MODEL	
	Wessex-HE 200	Wessex-HE County
Boiler Input kW (Gross) - maximum	238	476
Boiler Input kW (Nett) - maximum	219.5	439
Boiler Output kW - maximum	200	400
FLUE DATA		
Nominal Flue Spigot Internal Dia. (mm)	344	358
Approx. Flue Gas Temperature °C (Gross)	130	
Approx. Flue Gas Vol. (0°C – 1013mbar)@ 9.0% CO ₂ (m ³ /h)	268	536
GAS DATA		
Nominal Gas Inlet Press. (mbar)	37	
Maximum Gas Inlet Press. (mbar)	45	
Gas Flow Rate (m ³ /h)	8.9	17.8
Gas Setting Press. (mbar)	17.5	
Differential Pressure Switch Setting (mbar)	1.2 (Do not adjust)	
Orifice Dia. (mm)	10	
Gas Inlet Connection Pipe Thread Size	Rp1	
Pilot Injector Marking	35	

6.2 Exhaust Gas Volume and Temperatures

It is recommended that the volume and temperature of the waste gas shown below are used for the design of the flue system.

11.5.1 Gas Pressure Adjustment

After approximately 30 minutes of normal firing, connecting a differential manometer to test points A & B (either side of orifice) should check the gas pressure differential across the gas orifice (reference Figure No. 7). The pressure drop for Propane should be 17.5mbar and minor adjustments to the appliance governors may be necessary to correct for site gas pressure conditions.

Two double solenoid valves arranged in parallel control the main gas. Both valves have active governors situated between the solenoids. Remove the metal screw caps to reveal the adjusters beneath. Adjust both valves to obtain the pressure drop of 17.5mbar across the orifice.

NOTE: The above is a first order check. Final setting must be made using a gas meter.

11.5.2 Combustion Checks

A flue gas sampling point is provided in the front boiler casing (see Figure No. 5). To check combustion take a flue gas sample from each module test point and for reference CO₂ measurements should be between 9.5% and 10.5% or 6.5 to 5% O₂. Normal CO levels should not exceed 200ppm.

NOTE: All the above measurements refer to **dry flue gas** samples.

14.0 REPLACEMENT OF FAILED COMPONENTS

14.4 Main Solenoid Valve Renewal

If for any reason it is necessary to change one of the main solenoid valves, the correct model for propane firing **MUST** be fitted (HHL part no. 533903021 - 2off).

MODELS OF THIS BOILER INTENDED FOR PROPANE FIRING ARE FITTED WITH TWO ACTIVE GOVERNOR MAIN SOLENOID VALVES.

15.0 RECOMMENDED SPARES FOR WESSEX-HE 200 RANGE (PROPANE).

The following items replace, or are in addition to those listed in the main installer's guide.

DESCRIPTION	PART NO.
ELECTRICAL ITEMS	
Main Solenoid Valve	533903021
MECHANICAL ITEMS	
Pilot Injector (Propane) (marked 35)	532902043

Figure No. 6 – Wessex-HE 200 Module (Propane)

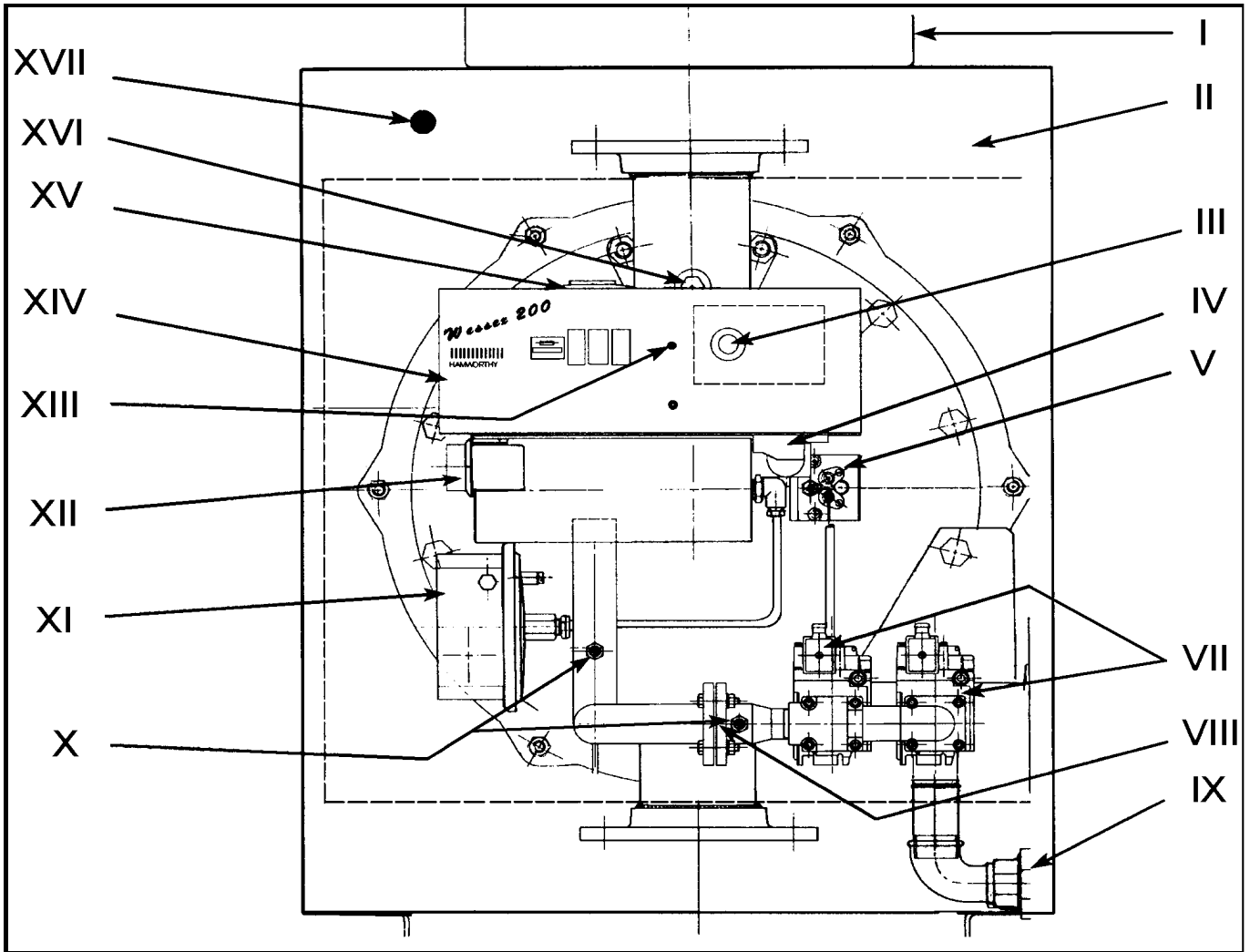

KEY: -

- I - BOILER FLUE CONNECTION
- II - BOILER CASING
- III - PROGRAMMER
- IV - GAS VALVE WIRING PLUG
- V - PILOT BURNER
- VI - NOT USED
- VII - MAIN GAS VALVES (2 OFF)
- VIII - GAS ORIFICE
- IX - Rp1 GAS CONNECTION
- X - PRESSURE TEST POINTS
- XI - DIFFERENTIAL PRESSURE SWITCH
- XII - CONTROL THERMOSTAT
- XIII - TEMPERATURE LIMITER
- XIV - FASCIA ASSEMBLY
- XV - FAN MOTOR
- XVI - THERMOSTAT POCKET
- XVII - FLUE GAS SAMPLING POINT

Figure No. 8 - Burner Flow System Schematic (Propane)

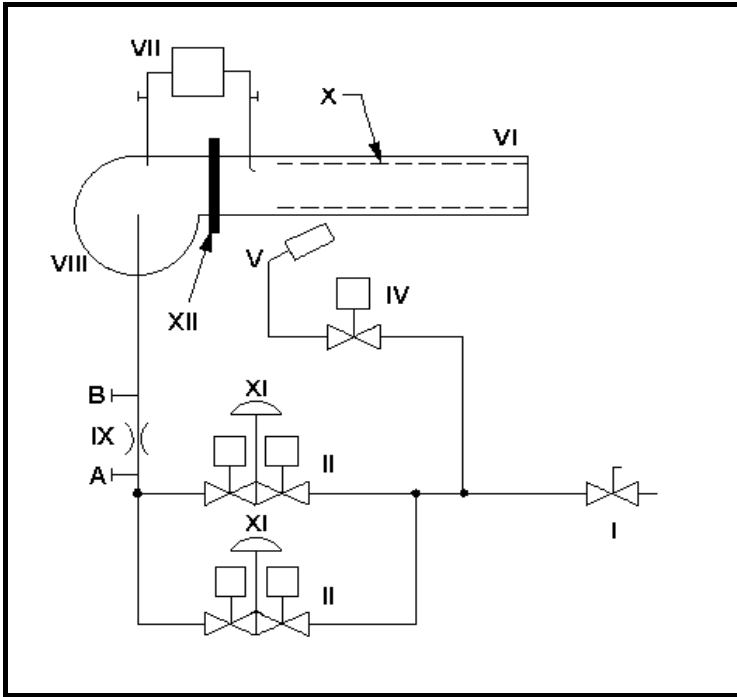

KEY: -

- I - Manual Gas Valve (Ball Type)
- II - Control Gas Valves
- III - Not Used
- IV - Pilot Gas Valve
- V - Pilot Burner
- VI - Main Burner
- VII - Differential Pressure Switch
- VIII - Burner Fan
- IX - Gas Orifice
- X - Burner Insert
- XI - Governor
- XII - Air Swirler

NOTES

NOTES

Notes

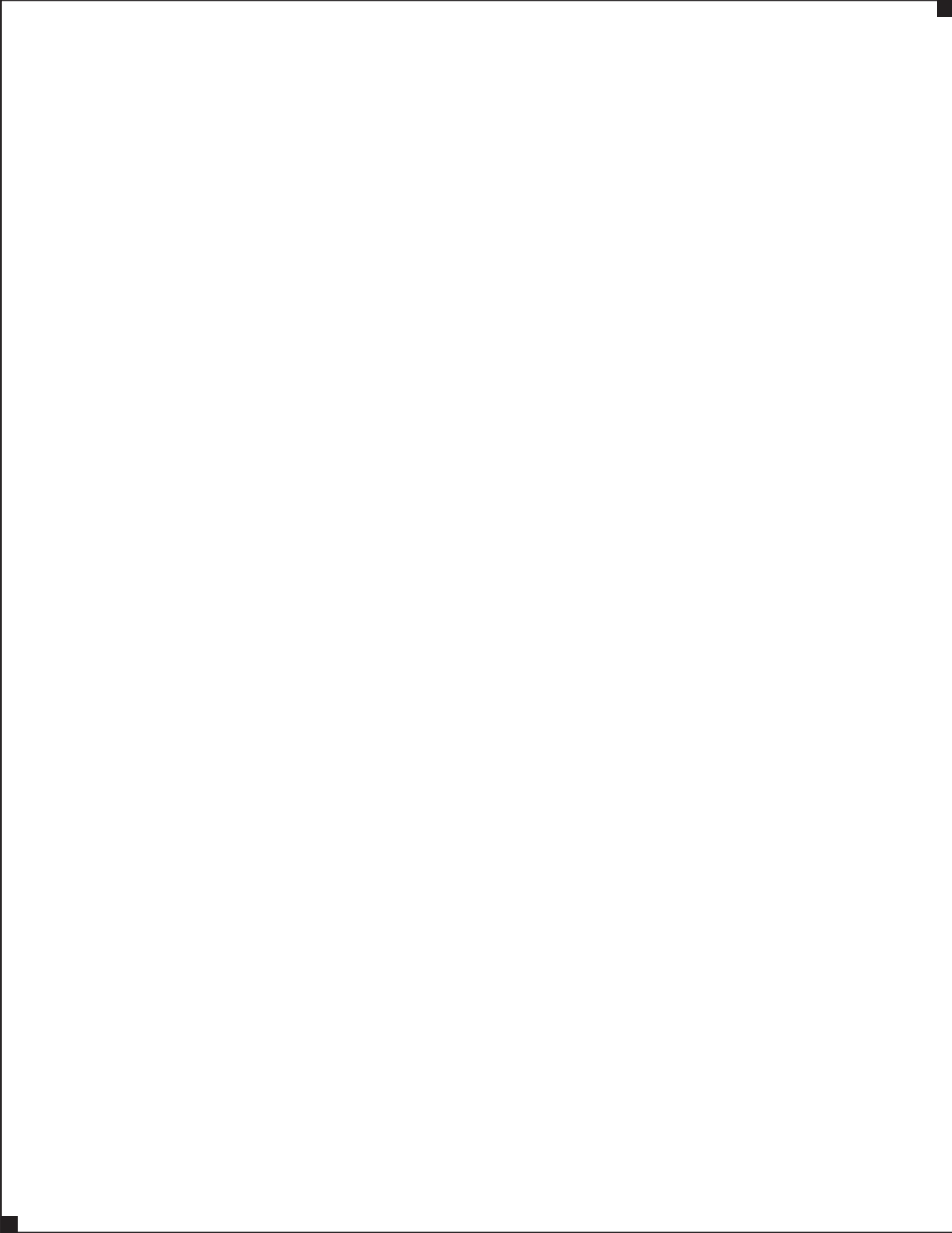

Connect direct





Direct Dial Telephone and Fax Numbers



- boilers
- controllers
- water heaters
- pressurisation sets

Poole Office

Hamworthy Heating Limited
Fleets Corner, Poole, Dorset BH17 0HH England
Main switchboard tel: **01202 662500**

Technical enquiries	 01202 662527/662528	 01202 665111
Spare parts	 01202 662525	 01202 665111
Service department	 01202 662555	 01202 662522



- flue components
- packaged fan dilution systems
- bespoke flue components
- bespoke flue systems
- design and installation

Birmingham Office

Hamworthy Heating Limited
Shady Lane, Great Barr, Birmingham B44 9ER
Main switchboard tel: **0121 360 7000** fax: **0121 325 2309**

General enquiries  **0121 360 7000**

Direct Email Addresses

Customer Services spares@hamworthy-heating.com
service@hamworthy-heating.com
technical@hamworthy-heating.com
sales.flues@hamworthy-heating.com

Hamworthy Heating Accredited Agents

North West England

Gillies Modular Services
210-218 New Chester Road, Birkenhead, Merseyside L41 9BG
tel: **0151 666 1030** fax: **0151 647 8101**

Southern Ireland

HEVAC Limited
Naas Road, Dublin 12, Ireland
tel: **00 3531 141 91919** fax: **00 3531 145 84806**

Northern Ireland

HVAC Supplies Limited
Unit 2, Antrim Line Business Park, Sentry Lane, Newtownabbey BT36 8XX
tel: **02890 849826** fax: **02890 847443**

Scotland

McDowall Modular Services
14-46 Lomond Street, Glasgow, Scotland G22 6JD
tel: **0141 336 8795** fax: **0141 336 8954**

North East England

Allison Heating Products
17 Beech Road, South Shields, Tyne & Wear NE33 2QH
tel: **0191 455 7898** fax: **0191 455 7899**

Website

www.hamworthy-heating.com

Associate Companies, Offices and Agents throughout the World.

Hamworthy reserves the right to make changes and improvements which may necessitate alteration to the specification without prior notice.