

LRP NT plus 1 – 14

Installation and operating instructions



Table of Contents

1.	Precautions	4
2.	Description	5
	2.1. General information	5
	2.2. Conformity and certificates	5
3.	Scope of supply	6
4.	Technical data / Dimensions	6
	4.1. Main data / operating conditions	6
	4.2. Water quality	6
	4.3. Dimensions	9
	4.4. Dimensions of custom made models	10
	4.5. Technical data	11
	4.6. Correction values for different operating conditions	13
5.	Boiler control panel	14
	5.1. Description	14
	5.2. Basic equipment NAVISTEM B1000 and B2000	14
	5.3. Additional equipment	14
	5.4. Heating regulators	14
	5.5. Cable set	14
6.	Installation guide	15
	6.1. Boiler room and boiler room ventilation	15
	6.2. Planning dimensions	15
	6.3. Placement into the boiler room	16
	6.4. Hydraulic connection / technical safety measures	17
	6.5. Electrical installation	17
	6.6. Turbulators	18
	6.7. Boiler control panel and casing assembly	18
	6.8. Connecting the burner	19
	6.9. Flue gas system	20
7.	Operating conditions	21
	7.1. Fuels	21
	7.2. Combustion air	21
	7.3. Filling the installation and water quality	21
	7.4. Protection against corrosion	21
	7.5. Requirements for operation	21
8.	Operation	22
	8.1. Commission	22
	8.2. Decommission	22
	8.3. First steps to take in case of failure	23
9.	Maintenance	24
	9.1. Periodical checks and maintenance operations	24
	9.2. Boiler cleaning	24
	9.3. Burner maintenance	24
10.	Spare parts	25

1. Precautions

STEPS TO BE TAKEN IN CASE OF DANGER

- Close fuel supply, disconnect unit from mains using emergency stop or main switch (outside of the boiler room).
- Use suitable fire extinguishers to extinguish flames.
- Occurrence of gas smell (gas units)
 - Ventilate the affected rooms thoroughly by opening doors and windows.
 - Do not use any electronic devices (mobile phone, etc.).
 - Do not activate any electrical contacts (light, motor, lift, door bell, etc.).
 - Do not ignite matches or lighters, and do not smoke.
 - Call the gas board or heating engineer.

PACKAGING

- After removing all packaging materials, check the contents to make sure that no damage has occurred during shipping. When in doubt, do not use the apparatus and contact the supplier.
- The packaging materials are to be disposed of properly.

THE BOILER UNIT

- Smooth boiler performance and manufacturer's guarantee are dependent upon adherence to the boiler installation, operation and maintenance instructions contained in this booklet.
- Never permit children or unauthorized persons to tamper with the equipment.
- The unit must be used only for its expressed application. All other uses are considered dangerous.
- The burner's minimum and maximum delivery settings, all pressures and temperatures must all be contained in the range stipulated in this manual.
- Modification of the equipment in order to alter its performance or applications prohibited.
- Do not open or tamper with components of the unit other than those parts of the unit that are subject to maintenance operations.
- Never touch the hot parts of the unit; these parts (flue gas conduit, sight glass, burner parts, etc) may remain hot for quite some time after the burner has switched off.
- Never touch the unit with wet parts of the body or without wearing shoes.
- When the unit is not to be used for a longer period, the main power switch on the electrical control panel must be switched off and the manual valve on the unit fuel supply line must be closed.
- The device contains components made of synthetic silicon mineral fibres (ceramic and glass fibres, insulation wool). These components must be disposed of appropriately at the end of their life cycle. Local regulations must be observed.

INSTALLATION AND SETTINGS

- The installation and calibration of the unit must be performed exclusively by qualified personnel in conformity with existing regulations and the indications provided in this Manual.

THE BOILER ROOM

- The boiler room must be lockable and its external air openings must conform to the norms prevailing locally. When in doubt regarding air circulation, measure the CO₂ count with the burner operating at its maximum delivery and the room ventilated only by the burner ventilation air openings and a second time with the door open. The CO₂ count measured in both cases must not differ. Should there be more than one unit in the same room, this test must be performed with all the equipment operating simultaneously.
- Never obstruct the boiler room's air openings, the burner fan suction opening, and any air ducts and ventilation.
- The equipment must always be protected against rain, snow, and freezing conditions.
- The boiler room must be kept clean and free of volatile substances that may be sucked into the fan and clog the inner burner or combustion head air ducts.
- The combustion air must be free of halogens (chlorine and fluorine compounds). If there is any doubt, the quality of the combustion air must be ensured with an external air intake.

ELECTRICAL INSTALLATION

- Electrical connections must be made exclusively by qualified personnel and all prevailing electrical regulations must be scrupulously observed.
- Make sure that the electrical power supply used for connection conforms to the specifications indicated on the rating plate and in this manual.

- The unit must be correctly connected to an efficient ground system in conformity to the prevailing norms and checked and controlled for efficiency by qualified personnel when in doubt.
- Never confuse neutral wires with phase wires.
- The unit must be hooked up to the electrical network with a plug-socket connection that is such as to prevent inversion of phase and neutral. Install a master switch for the heating plant as requested by existing legislation.
- The entire electrical system, and all cable sections in particular, must be adequate to deliver the maximum absorbed power value indicated on the equipment's rating plate and in this manual.
- If the mains power cable is found to be defective, it must be replaced only by qualified personnel.
- Never stretch power supply cables and keep them well away from sources of heat.

FUEL

- The unit must be fed with the type of fuel for which it has been preset as indicated on the rating plate.
- The fuel pressure must be according to the values listed in the burner manual.
- The fuel line that feeds the unit must be sized according to the requirements of local regulations and the prescriptions in the burner manual. The line must be perfectly sealed. The fuel supply line must also be equipped with all the control and safety mechanisms required by local regulations in force. The line must be free from all impurities; take particular care that foreign matter does not enter the line during installation.
- Oil:
 - The light oil storage tank must be adequately protected against penetration of impurities and water. The fuel tank must be kept full of fuel during the summer in order to avoid the condensation of humidity. Clean the tank carefully before filling. Beware not to overfill the tank.
 - Both the tank and the unit fuel supply line must be protected from frost.
 - Oil consumption and tank unit must be checked regularly, in order for leaks to be detected in good time.
- Gas:
 - The gas line must be checked for leakage during commissioning and after each disconnection.

MALFUNCTION

- If the unit stops working and goes into lock-out and does not resume operation after two or three manual lock-out reset attempts, disconnect the power supply, do not attempt to repair, and contact a qualified specialist.
- All repairs required must be performed exclusively at a technical servicing and/or technician centre authorized by the manufacturer using original spare parts only. Failure to observe the above may compromise the reliability and safety of the equipment.
- Any failure or damage resulting from improper use or intentional damage will relieve the manufacturer from any guarantee obligation.

MAINTENANCE

- Maintenance must be performed by qualified personnel regularly or at least once a year.
- Prior to performing any maintenance operations, switch off the power supply by using the main switch and cut off the fuel supply as well.
- Only parts indicated by the manufacturer in the Spare Parts Catalogue may be replaced.
- In order to avoid all types of health hazards, suitable clothing and a protective mask must be worn for work on or with components made of synthetic silicon mineral fibres (ceramic and glass fibres, insulation wool).

2. Description

2.1. General information

Pyronox LRP NT PLUS boilers are high efficiency, power-saving low temperature boilers ranging from 70 to 580 kW and from 65 to 500 kW for low-NOx applications. They can be operated in combination with oil or gas burners. Pyronox LRP NT PLUS boilers are three pass, smoke tube boilers with combustion chamber and flue way using the Low-Nox technology. The third pass is equipped with turbulators. Their turbulent action further increases the heat exchange and allows the system to work at low combustion gas temperatures, guaranteeing optimal fuel use as a result.

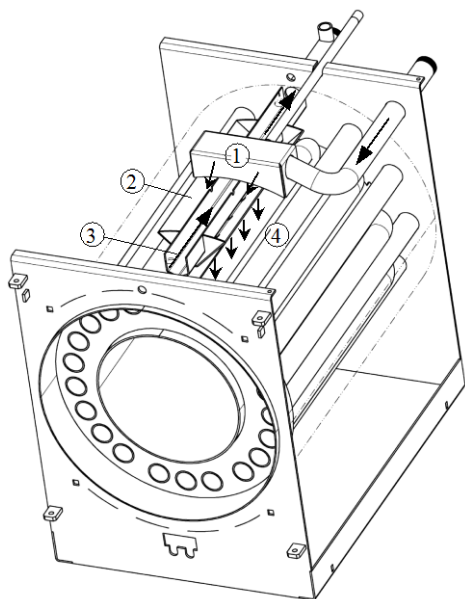
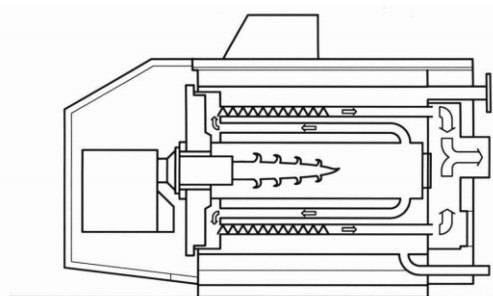

The PYROFLOW system simplifies the conception of the installation and considerably improves profitability and reliability.

The idea behind the PYROFLOW system is to heat the cold return water by means of internal heat exchange and mixing with the warm boiler water.

The cold return water is fed to a distributor (1) and from there into collector (2), which completely encapsulates the internal supply pipe (3). The return water is preheated within this collector. Calibrated holes (4) all along the bottom of the collector guide the water towards the furnace while preventing any contact with the flame tubes. The hot furnace surface further heats the water, which is consecutively mixed with the boiler content.

The supply temperature is governed by means of the numerical Ygnis governor, which pilots the mixing valves of the hydraulic groupes, or in case of cascades, the closing valve of the boiler in question.

The symmetrical geometry of the boiler and the large water volume assure a homogeneous temperature distribution and an unhindered natural convection.

This concept, coupled with the Ygnis patented flame escape system, also allow users to obtain low emission values and safe operation in conformity with law provisions.

The boiler's thermal insulation is made of glass fibre felt that adheres to the boiler shell, guaranteeing minimal loss in stand-by mode.

A soundproofing hood can be optionally provided that covers the whole of the front of the boiler, with which burner noise can be kept down to a minimum and thermal radiation can be further reduced.

In addition, the front part of the boiler is provided with superior quality ceramic fibre insulation. A revolving door gives easy access to parts of the boiler that are in contact with combustion gases. This allows cleaning of combustion chamber and passage ways to be easily performed from the front.

The combustion gas collector on the rear of the boiler is provided with an opening for easy cleaning.

The boiler's thick casing is easy and quick to install. Casing plates are painted with an environment-friendly paint, so they are permanently protected from corrosion.

A divided version of the boiler range can be made available as custom made option. Thanks to the inferior dimensions of the individual parts, this version is most suitable when bringing-in conditions are tight. The individual prefabricated parts must be welded together in the boiler room.

2.2. Conformity and certificates

This boiler fulfills the requirements of the low voltage directive 2006/95/CE, of the EMC-directive 2004/108/CE and the efficiency directive 92/42/CE for low temperature boilers as well as the GAD 2009/142/CE.

The boiler range with ECA-rating has efficiencies in conformity with the requirements of the Enhanced Capital Allowance Scheme (ECA).

The Directive 2009/142/EC and its rule of application EU 813/2013 of 02 August 2013, laying down the requirements of eco-design applicable to devices of heating premises, relates only to the products ≤ 400 kW. Based on this:

The LRP NT PLUS Models 1 to 11 are not intended for heating the premises,

The LRP NT PLUS models 12 to 14, which are not affected by these requirements, can be used for heating premises.

CE certificate CE/0461

3. Scope of supply

- Boiler body, flue gas collector and flue gas tube
- Gas-tight boiler door, with insulation and burner connection
- Furnace sight glass integrated in the boiler door
- Supply and return tubes with flanges, counterflanges, gaskets and screws
- Filling and discharge tubes
- Automatic venting valve
- Flue gas turbulators
- Boiler insulation
- All-around casing (packed separately)
- Heat and sound proofing hood or front isolation (optional)
- Boiler control panel (version depending on order)
- Burner pipe insulation material (supplied loose)
- Cleaning set
- Installation and operating instructions

4. Technical data / Dimensions

4.1. Main data / operating conditions

Max. operating pressure		4,0 bar g
Test pressure		6,0 bar g
(other pressures on request)		
Min. operating pressure		0,5 bar g
Boiler supply and return pipe flanges		PN 6
Safety cut-out temperature		110 °C
Max. operating temperature		90 °C
Operating temperatures		
With Ygnis control:		no restrictions
Without Ygnis control:		
- Min. operating temperature		
	with fuel oil	50 °C
	with natural gas	60 °C
	with propane	60 °C
- Min. return temperature		15 °C
Min. flue gas temperature:		
with fuel oil	S-content:	
	50 ppm	100 °C
	500 ppm	110 °C
	0.1%	115 °C
	0.2%	120 °C
	0.5%	125 °C
with natural gas	S-content:	
	10 mg/nm3	95 °C
	150 mg/nm3	110 °C
Max. CO ₂ -content	with fuel oil	15.5%
(dry flue gas)	with natural gas	11.7%
	with propane	13.7%

4.2. Water quality

The following rules apply once the boiler is put into service and remain valid until the end of life of the product.

Preparing the water system before putting the boiler into service

For any installation (new or renovation), the water system pipes must be thoroughly cleaned. The purpose of this initial cleaning is to eliminate germs and residue that can cause deposits to form.

In **new installations** in particular, residue from grease, oxidised metal, and even copper microdeposits must be removed.

In **renovated installations**, cleaning should focus on removing sludge and the products of corrosion formed when the unit was last in operation.

There are two types of methods for cleaning and removing sludge: a high intensity approach that takes a few hours and a slower, more gradual approach that takes several weeks. This first type of cleaning must be done **before connecting the new boiler**, and with the second type, a filter should be installed on the back of the boiler to capture loosened deposits.

The cleaning performed prior to installation improves performance, reduces energy consumption, and resists scaling and corrosion on the unit. A professional (water treatment) should carry out the cleaning.

Protecting the unit against scaling

Water naturally contains dissolved calcium ions and carbonates that cause scaling (calcium carbonate) to form. To prevent excessive deposits, take precautions with regard to the **water used to fill the unit: TH < 10°f**

Water must be added during the life of the boiler. The new water adds scaling to the water system. **The amount of fill water plus the amount of make-up water added during the life of the unit should not be more than three times the water capacity of the heating system.** Also, the hardness of the make-up water must be controlled. **Make-up water: TH < 5 °f**

Adding a large amount of untreated water always contributes a significant amount of scaling. To monitor this and to detect problems, **a system water meter must be installed.**

Failure to comply with these guidelines (such that the fill water plus the make-up water is more than three times the water capacity of the heating system) requires a full cleaning (to remove sludge and scaling) to be performed.

Additional precautions are required for operation:

- ✓ When the unit has a water softener, the equipment must be inspected on a regular basis in order to ensure that it is not outputting chloride-rich water into the system. The concentration of chlorides must always remain below 50 mg/l.
- ✓ To prevent the build-up of calcium deposits (such as on exchange surfaces), the unit should be brought into service slowly, starting by operating at a low power with high primary water flow.
- ✓ When the tap water lacks the desired qualities, **water treatment is required.** The fill water must be treated, and whenever new water is added, the make-up water must also be treated.
- ✓ Installations with multiple boilers require all of the boilers to be brought up simultaneously at minimal power. Doing this prevents the calcium in the water from depositing on the exchange surfaces of the first boiler.
- ✓ When working on the unit, avoid draining it completely; only the required parts of the system are to be drained.

The rules listed above are designed to minimise scaling on the exchange surfaces and thus to increase the life of the boilers.

To optimise how the equipment operates, plan to remove its calcium deposits. This must be done by a specialized company. Also, before putting the unit into service, verify that the heating system is not damaged (ex. leaks). If it has excessive scaling, the unit's settings for operation and for water treatment must be adjusted.

Protecting steel and stainless steel boilers against corrosion

Corrosion can affect the iron components used in boilers and heating systems, which is directly related to the presence of oxygen in the water heater's water. Dissolved oxygen that enters the unit when it is being filled for the first time reacts with the equipment materials and quickly disappears. Without refreshing the oxygen through significant contributions of water, the unit might not experience any damage whatsoever.

However, it is important to follow the sizing rules and installation guidelines in order to prevent oxygen from continuously flowing into the heating water. From these rules, we have:

- ✓ Preferably an expansion vessel with a membrane rather than an open expansion vessel that allows direct passage
- ✓ Internal pressure with the unit of more than 1 bar cold
- ✓ Remove leaky (permeable) components that are letting out more gas than as if they were sealed.

If the guidelines above are followed, the unit's system water has the proper characteristics to last a long time:

8.2 < pH < 9.5 with a water concentration of < 0.1 mg/l.

If there is a chance that oxygen could enter the unit, you must take additional precautions. Adding an oxygen scavenger (ex. sodium sulphite) is highly recommended. We recommend directing any water treatment questions to specialists, which can provide:

- The appropriate treatment based on the characteristics of the unit
- A monitoring agreement with a guarantee as to the results

For units in which **the water comes into contact with heterogeneous materials**, such as copper or aluminium, **appropriate treatment is recommended** in order to ensure that the unit will last. In most cases, this consists of adding corrosion inhibitors (in the form of chemical solutions) to the unit. Referring to a water treatment specialist is recommended.

Setting up a filtration system

A filtration system on the back of the boiler is recommended in order to remove suspended particles from the unit.

Choice of burner / boiler

We recommend adopting modulating burners to avoid thermal shock in operation.

Hydraulic

Set up an effective degasser as close as possible to the boiler outlet to evacuate the air from the networks introduced during the filling and the addition of water in order to maintain a good convection coefficient.

Add an additional expansion vessel if the characteristics of the pressure maintenance unit do not allow the pressure variations to be limited to 0.5 bar in order to limit the variations in hydraulic pressure.

No minimum flow rates recommended for boilers equipped with a Navistem B2000 or equivalent system to control the minimum flow temperature. In the opposite case, respect a flow rate of $P / 45$, in accordance with the General Conditions of Sale (P = Power in th / h provided at time t).

Exploitation

The frequency of cold starts should be as low as possible; during these periods, the flue gas temperature can be low and cause condensation that is detrimental to the life of the boiler; it is recommended not to exceed a cold start per week.

During a cold start, the heat emitters of the installation will be irrigated when the set temperature is reached; the temperature rise of the installation will be carried out at minimum power.

Do not shut off the burner at full load to avoid temperature shock.

Do not hesitate to add buffer volumes to the plant's hydraulic system to avoid short operating cycles, especially when the boiler is protected by an isolation plate heat exchanger. Regarding the regulation of the installation, we recommend burner modulation parameters (PID) sufficiently slow to ensure stability and low temperature variations, start / stop differentials / hysteresis must be reasonable in order to leave a range of operation sufficient for the burner and to ensure its modulation (value ± 4 ° C). All strategies must allow the burner to be started up for an average operating time of 30 minutes.

The temperature variations of the boiler must be as low as possible to ensure the highest service life.

The first heating must allow the evacuation of moisture from concrete doors, it is necessary to avoid any heat shock and adopt a rise in temperature as slow as possible.

Do not hesitate to adopt the burner's burner maintenance accessories to minimize structural vibration of the burner assembly.

Unit monitoring

If the recommendations listed above (new installation or renovation) have been followed, the unit monitoring is limited to:

- Checking the amount of make-up water (fill water volume + make-up water volume < 3 times the unit volume)
- Checking the pH level (stable or slightly increasing)
- Checking the total hardness (stable or slightly decreasing)

We recommend monitoring these parameters two to three times a year. Note: Monitoring the quantity of make-up water is critical to the long life of the unit.

If any of these parameters deviates from the above recommendations, refer to a water treatment specialist to correct the problem.

Setting up a plate exchanger

If the recommendations listed above cannot be met, you can set up a plate exchanger to separate the primary system from the secondary system, which protects the boiler from undesirable effects.

4.3. Dimensions

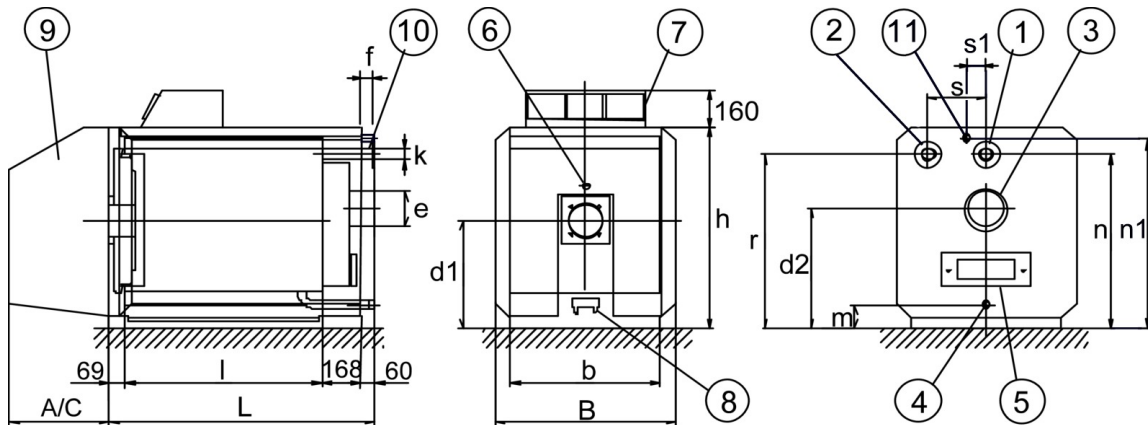

0001AX

- 1 Supply PN6 4 Fill/discharge grille 1" 7 Boiler control 10 Safety valve connection "q" on supply pipe
- 2 Return PN6 5 Cleaning lid 8 Passage for burner cables 11 Automatic vent valve 3/8"
- 3 Comb. gas grille 6 Inspection window 9 Thermal insulation hood

LRP NT plus			1	2	3	4	5	6	7	8	9	10	11	12	13	14
Boiler length	L	mm	1141	1141	1283	1283	1483	1483	1483	1742	1742	1742	1742	1998	1998	1998
Boiler feet length	l	mm	844	844	986	986	1186	1186	1186	1445	1445	1445	1445	1701	1701	1701
Boiler width	B	mm	770	770	870	870	870	870	920	920	920	1000	1000	1068	1068	1068
Boiler feet insert width *	b	mm	640	640	740	740	740	740	790	790	790	870	870	938	938	938
Boiler height	h	mm	880	880	955	955	955	955	1040	1040	1040	1120	1120	1208	1208	1208
Burner flange centre	d1	mm	470	470	500	500	500	500	550	550	550	590	590	624	624	624
Distance supply / return	s	mm	250	250	250	250	250	250	275	275	275	355	355	374	374	374
ø supply / return PN6	k	DN	1 1/2"	1 1/2"	50	50	50	50	65	65	65	65	65	80	80	80
ø safety valve connection	q	DN	3/4"	3/4"	1"	1"	1"	1"	1 1/4"	1 1/4"	1 1/4"	1 1/4"	1 1/4"	1 1/2"	1 1/2"	1 1/2"
Height supply connection	n	mm	757	757	835	835	835	835	900	900	900	978	978	1053	1053	1053
Height return connection	r	mm	757	757	835	835	835	835	933	933	933	993	993	1069	1069	1069
Lenght supply & return	f	mm	60	60	70	70	70	70	80	80	80	80	80	90	90	90
Height flue	d2	mm	520	520	550	550	550	550	600	600	600	640	640	674	674	674
Flue outside diameter	e	mm	150	150	150	150	150	150	200	200	200	200	200	250	250	250
Discharge height	m	mm	100	100	88	88	88	88	103	103	103	104	104	104	104	104
Distance vent valve - supply	s1	mm	69	69	99	99	99	99	144	144	144	144	144	144	144	144
Height vent valve	n1	mm	830	830	905	905	905	905	989	989	989	1069	1069	1157	1157	1157
Short sound-proof. hood	A	mm	535	535	605	605	605	605	605	605	605	605	605	1030	1030	1030
Long sound-proof. hood	C	mm	725	725	890	890	890	890	890	890	890	890	890	1280	1280	1280

Weight empty	G	kg	283	284	393	394	447	448	522	606	607	731	733	973	976	980
Boiler water content	V	L	130	130	185	185	220	220	260	315	315	360	360	540	540	540
Boiler gas content	VG	m³	0.15	0.15	0.22	0.22	0.26	0.26	0.32	0.38	0.38	0.46	0.46	0.61	0.61	0.61
Furnace diameter	DF	mm	342	342	415	415	415	415	463	463	463	508	508	530	530	530
Furnace length	LF	mm	768	768	910	910	1110	1110	1107	1366	1366	1366	1366	1618	1618	1618
Furnace volume	VF	L	70.6	70.6	123.1	123.1	150.1	150.1	186.4	230.0	230.0	276.9	276.9	357.0	357.0	357.0

* without insulation material

06/07/TN

4.4. Dimensions of custom made models

The following custom made models are available on request. They are however subject to different delivery times!

4.4.1. Different operating pressures

Pyronox LRP NT Plus boilers can be provided for the operating pressures of 6, 8 and 10 bar-g. Their dimensions and performances are identical to those of the standard range, with the following exceptions:

LRP NT plus 6 bar			1	2	3	4	5	6	7	8	9	10	11	12	13	14
Weight empty 6 bar	G	kg	294	295	404	405	470	471	542	629	630	747	749	1031	1034	1038

LRP NT plus 8 & 10 bar			1	2	3	4	5	6	7	8	9	10	11	12	13	14
Weight empty 8 bar	G	kg	310	311	430	431	531	532	617	711	712	830	832	1079	1082	1086
Weight empty 10 bar	G	kg	328	329	478	479	541	542	617	711	712	909	911	1193	1196	1200
Lenght supply & return	f	mm												114	114	114

05/07/TN

4.4.2. Divided version

Also available as a custom made option is a divided version of the Pyronox LRP NT Plus 7 - 14. Thanks to the inferior dimensions of the individual parts, this version is most suitable when bringing-in conditions are tight. The individual prefabricated parts must be welded together in the boiler room.

Attention: The welding work may only be performed by a qualified welder licenced to weld pressurized vessels.

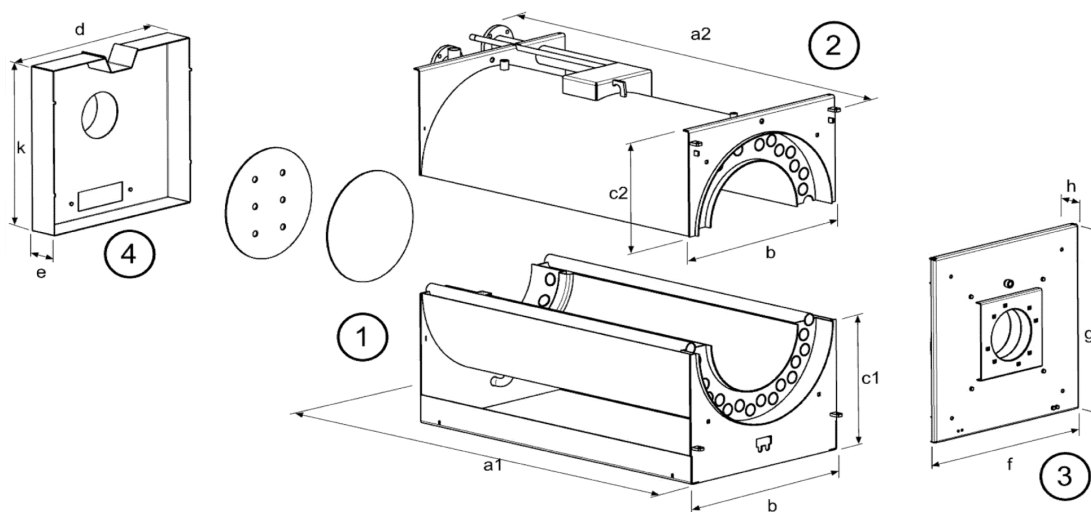

22989

Dimensions

LRP NT Plus		7	8 / 9	10 / 11	12-14
a1	mm	1453	1712	1712	1968
a2	mm	1473	1732	1732	1997
b	mm	790	790	870	938
c1	mm	550	550	590	638
c2	mm	463	463	496	546
d	mm	740	740	820	884
k	mm	700	700	780	866
e	mm	227	227	227	227
f	mm	780	780	856	920
g	mm	780	780	856	920
h	mm	115	115	115	116

Weight for 4 bar

LRP NT Plus		7	8 / 9	10 / 11	12-14
1	kg	205	245	299	413
2	kg	185	219	269	354
3	kg	33	33	39	53
4	kg	24	24	27	30

Weights for 6, 8 and 10 bar on request

4.5. Technical data

The power indicated is the maximum power that the corresponding heating body model can deliver. The selected burner and the output or polluting emissions (NOx) constraints may require the burner to be set at a lower calorific flow value.
For more information, please contact the after sales department.

4.5.1. Pyronox LRP NT plus

Technical specifications LRP NT plus (fuel oil)

LRP NT plus				1	2	3	4	5	6	7	8	9	10	11	12	13	14
Power																	
Boiler nominal power q _N (80/60°C)	max.		kW	70	90	120	145	165	190	225	260	300	335	370	440	510	580
	min.	2		39	43	59	65	69	76	93	100	115	135	154	190	216	259
	min.	3		28	31	42	46	49	53	62	60	67	80	89	103	117	158
Calorific power q _F	max.		kW	76	98	130	158	179	207	245	284	329	366	405	478	556	634
	min.	2		41	46	62	69	73	80	98	105	122	143	162	201	228	273
	min.	3		29	32	44	48	51	56	65	62	71	84	93	108	122	165
Modulation rate 60 / 80 °C		2		54%	47%	48%	44%	41%	39%	40%	37%	37%	39%	40%	42%	41%	43%
		3		38%	33%	34%	30%	28%	27%	27%	22%	22%	23%	23%	23%	22%	26%
Modulation rate @ t _m = 40 °C		2		75%	64%	67%	63%	65%	61%	64%	61%	57%	61%	60%	67%	62%	62%
		3		60%	51%	53%	47%	45%	45%	47%	44%	42%	45%	45%	49%	47%	48%
Efficiencies																	
Overall efficiency 60 / 80 °C	100%		%	92.0	91.6	92.2	91.7	92.0	91.5	91.7	91.7	91.2	91.6	91.4	92.1	91.7	91.4
Overall efficiency @ t _m =40 °C	30%	2	%	94.6	94.7	94.8	94.8	94.9	95.0	94.9	95.0	95.0	95.0	95.0	95.0	95.1	95.1
Overall efficiency @ t _m = 40 °C	30%	3	%	95.6	95.7	95.7	95.8	95.8	95.9	95.9	95.9	96.0	96.0	96.0	96.0	96.0	96.0
Efficiency DIN4702-8, 60 / 75 °C	η _N	2	%	93.7	93.9	94.0	94.1	94.2	94.3	94.3	94.3	94.3	94.4	94.4	94.5	94.6	94.6
Mass flows																	
Fuel oil flow	max.	1	kg/h	6.4	8.3	10.9	13.3	15.1	17.5	20.7	24.0	27.8	30.9	34.2	40.3	46.9	53.5
	min.	1,2		3.5	3.9	5.3	5.8	6.1	6.8	8.3	8.9	10.3	12.0	13.7	16.9	19.2	23.0
Exhaust gas mass flow	max. wet		kg/s	0.03	0.04	0.06	0.07	0.08	0.09	0.11	0.12	0.14	0.16	0.17	0.21	0.24	0.27
	min. wet	2		0.02	0.02	0.03	0.03	0.03	0.03	0.04	0.05	0.05	0.06	0.07	0.09	0.10	0.12
Exhaust gas data, losses																	
Overpressure combustion chamber	max.		mbar	0.44	0.86	0.98	1.61	1.77	2.64	1.97	2.27	3.43	2.83	3.80	2.48	3.75	5.74
Exhaust gas temperature at 80/60 °C	max.		°C	176	187	175	187	183	192	189	191	201	192	197	181	191	196
	min.	2		120													
	min.	3		100													
Exhaust gas losses at 80/60 °C	max.		%	7.3	7.9	7.3	7.9	7.7	8.1	8.0	8.1	8.6	8.1	8.4	7.6	8.1	8.4
Stand-by loss q _B	70 °C		W	343	343	442	442	451	451	539	552	552	659	659	779	779	779
Hydraulic data																	
Water resistance	Δt=10K		mbar	43	71	40	58	76	100	48	66	87	108	132	81	108	140
	Δt=20K			11	18	10	15	19	25	12	17	22	27	33	20	27	35
Water flow	max.		m ³ /h	6.0	7.7	10.3	12.5	14.2	16.3	19.3	22.3	25.8	28.8	31.8	37.8	43.8	49.8
Operating temperatures	max.		°C	90													
	SCO			110													

Values acc. EN304 at:
 - λ=1.2, CO₂=12.7%
 - T_{air}=20°C, rel. humidity=60%, p_{baro}=100kPa
 1: LCV = 11.85 kWh/kg
 2: Sulphur content up to 0.2%
 3: Max. sulphur content 0.005% (50 ppm)

3zugskessel, V-07/06
OG

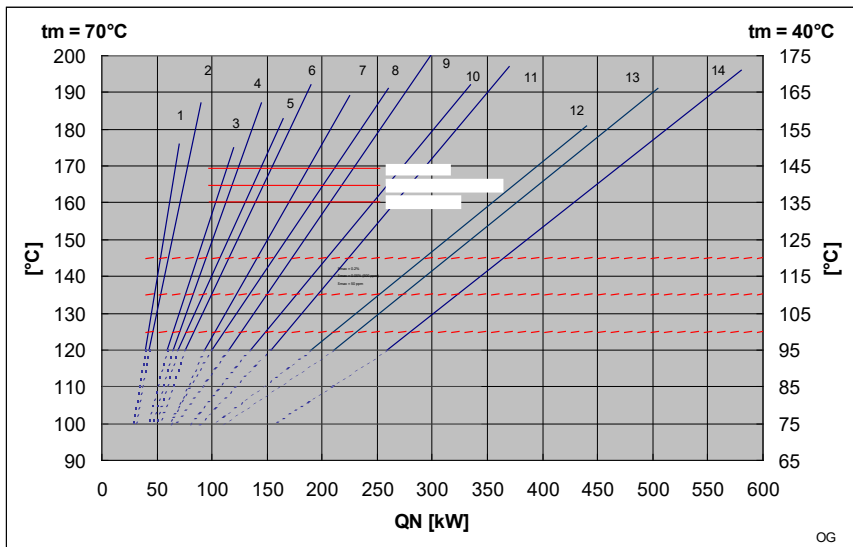

Flue gas temperature diagram LRP NT PLUS, fuel oil with clean boiler
 t_m = average boiler temperature (see also chap. 4.6.1)

LRP NT plus 1 - 14

Technical specifications LRP NT plus (natural gas)

LRP NT plus				1	2	3	4	5	6	7	8	9	10	11	12	13	14
Power																	
Boiler nominal power qN (80/60°C)	max.		kW	70	90	120	145	165	190	225	260	300	335	370	440	510	580
	min.	3		25	26	36	41	43	48	54	52	58	70	78	91	101	125
Calorific power qF	max.		kW	76	99	130	158	179	207	245	284	329	366	406	478	557	635
	min.	3		26	28	38	43	45	50	56	54	61	73	81	96	106	130
Modulation rate	80/60°C			34%	28%	29%	27%	25%	24%	23%	19%	19%	20%	20%	20%	19%	20%
	@ tm=40°C			55%	47%	49%	44%	41%	40%	42%	39%	38%	41%	41%	44%	42%	44%
Efficiencies																	
Overall efficiency 60 / 80 °C	100%		%	91.9	91.5	92.1	91.6	91.9	91.4	91.6	91.6	91.1	91.5	91.2	92.0	91.5	91.3
Overall efficiency @ tm=40 °C	30%		%	95.8	95.9	95.9	96.0	96.0	96.1	96.1	96.1	96.2	96.1	96.2	96.2	96.2	96.3
Efficiency DIN4702-8, 60 / 75 °C	ηN		%	94.4	94.4	94.5	94.5	94.6	94.6	94.6	94.5	94.6	94.7	94.7	94.8	94.9	95.0
Mass flows																	
Gas flow, NG type E	max.	1.2	nm³/h	7.6	9.9	13.1	15.8	18.0	20.8	24.6	28.5	33.0	36.7	40.7	48.0	55.9	63.7
	min.	1.2		2.6	2.8	3.8	4.3	4.5	5.0	5.7	5.5	6.1	7.4	8.1	9.6	10.6	13.1
Exhaust gas mass flow	max. wet		kg/s	0.03	0.04	0.05	0.07	0.07	0.09	0.10	0.12	0.14	0.15	0.17	0.20	0.23	0.27
	min. wet			0.01	0.01	0.02	0.02	0.02	0.02	0.02	0.02	0.03	0.03	0.03	0.04	0.04	0.05
Exhaust gas data, losses																	
Overpressure combustion chamber	max.		mbar	0.45	0.84	1.00	1.64	1.81	2.69	2.21	2.31	3.50	2.88	3.88	2.53	3.83	5.86
Exhaust gas temperature at 80/60 °C	max.		°C	177	188	176	188	184	193	189	191	202	192	198	182	192	197
	min.	3		95													
Exhaust gas losses at 80/60 °C	max.		%	7.5	8.0	7.4	8.0	7.8	8.3	8.1	8.2	8.7	8.2	8.5	7.8	8.3	8.5
Stand-by loss qB	70 °C		W	343	343	442	442	451	451	539	552	552	659	659	779	779	779
Hydraulic data																	
Water resistance	Δt=10K		mbar	43	71	40	58	76	100	48	66	87	108	132	81	108	140
	Δt=20K			11	18	10	15	19	25	12	17	22	27	33	20	27	35
Water flow	max.		m³/h	6.0	7.7	10.3	12.5	14.2	16.3	19.3	22.3	25.8	28.8	31.8	37.8	43.8	49.8
Operating temperatures	max.		°C	90													
	SCO			110													

Values acc. EN303-3 at:
 - λ=1.15, CO2=10%
 - T-air=20°C, rel. humidity=60%, p-baro=100kPa
 1: LCV = 9.97 kWh/nm³
 2: nm³ at 0°C, 1013 mbar
 3: S max = 10 mg / nm³

3zugskessel, V-07/06
GG

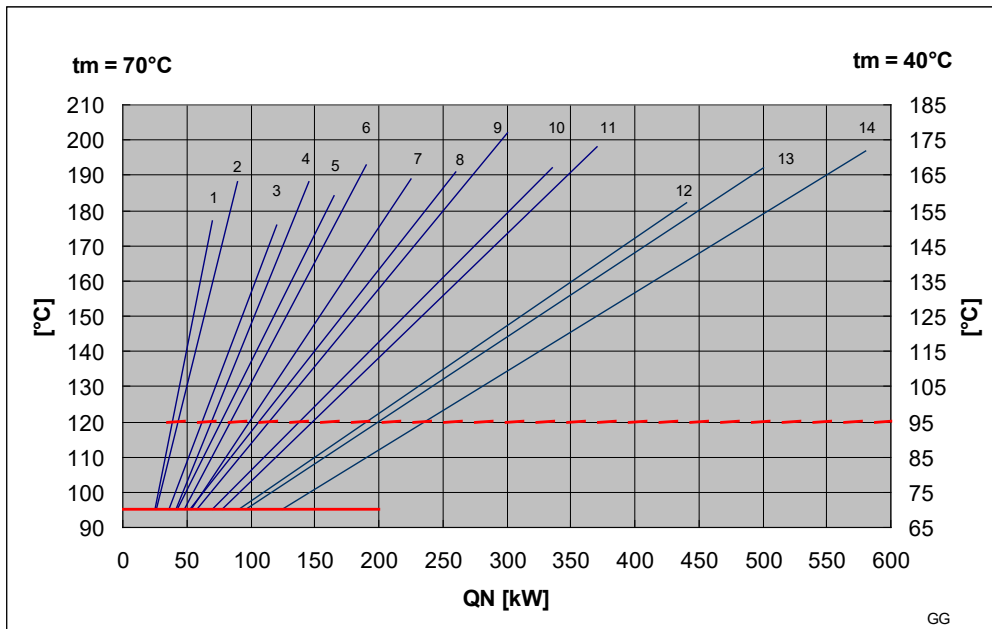

Flue gas temperature diagram LRP NT PLUS, natural gas with clean boiler
 tm = average boiler temperature (see also chap. 4.6.1)

4.6. Correction values for different operating conditions

4.6.1. Flue gas temperature correction values

Average boiler water temperature	t °C	40	50	60	70	80	90
Flue gas temperature difference	Δt K	-25	-16	-8	± 0	+8	+16

Excess air	λ -	1.10	1.15	1.20	1.25	1.30	1.35
Flue gas temperature difference	Δt K	-6	-3	± 0	+3	+6	+8

4.6.2. Modulation range

The minimum power of the boiler is limited by the minimum allowable flue gas temperature. Consequently, the modulation range increases when the average boiler temperature increases. This is exemplarily illustrated in the figure below (example for oil operation with a minimum flue temperature of 120°C).

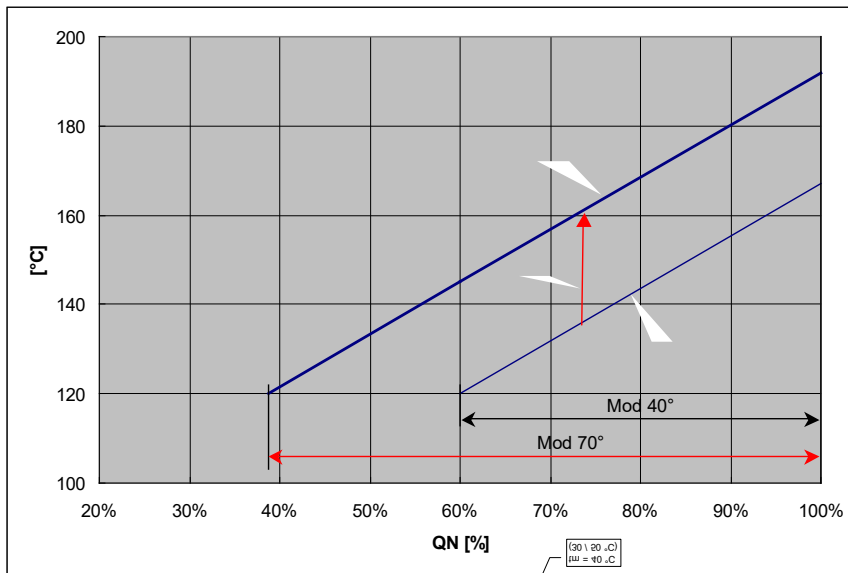

Flue gas temperature – Boiler power diagram, example for two average boiler water temperatures

4.6.3. Stand-by loss correction values

Average temperature difference *	Δt_m	°C	30	40	50	60	70
Stand-by loss correction	Δq_B	%	-40	-20	± 0	20	40

* Average temperature difference = Average boiler water temperature minus ambient air temperature
 Average boiler water temperature = Average of supply and return temperature

5. Boiler control panel

5.1. Description

Pyronox LRP NT PLUS boilers require the use of a control panel equipped with a regulator to avoid condensation in the heater (NAVISTEM B2000 control panel with RVS 63 regulator or equivalent system).

The RVS 63 heating regulator enables management of the operation of the burner, heating circuits and domestic hot water production.

It has digital logic to protect the boiler against cold starting and manage the flow of return water in relation to its temperature by acting on the three-way valves of the heating circuit or to the boiler's insulation valve.

NAVISTEM B2000 control panels are supplied ready to be connected. **The regulators must be set according to the recommendations in the instructions provided in the control panel to protect the boiler against condensation.** Settings must also be adapted to comply with the system's hydraulic configuration (circuits for heating, domestic hot water, etc.). The steel sheet housing is ready to be mounted on top of the boiler cover.

The electrical diagram is attached to the control panel.

5.2. Basic equipment NAVISTEM B1000 and B2000

- Burner ON / OFF switch
- 6.3 A H 250VAC fuse for burner
- 6.3 A H 250VAC fuse(s) for regulator(s)
- Safety thermostat
- Regulating thermostat for 1st and 2nd speed (2nd speed inactive for a NAVISTEM B2000 panel with RVS 63 regulator)
- Overheat indicator
- Burner safety indicator
- External fault indicator
- Water thermometer

5.3. Additional equipment

- Timer and pulse counter speeds 1 and 2
- Dry contacts module / overheating fault, burner fault, burner operation at speed 1, burner operation at speed 2, external fault indicators
- Dry contacts module and burner reset
- Three-phase burner power supply
- RVS 46 additional heating regulator (management of a mixer valve circuit)

5.4. Heating regulators

RVS 46 regulator (optional on the NAVISTEM B2000 control panel)

Regulator not included in the basic panel (sold as additional equipment):

- Slave heating regulator to control a mixer valve heating circuit
- Return temperature mixer valve protection: protection against condensation in the steel heater when the RVS 63 outputs are already used to manage two heating circuits.

RVS 63 regulator (included as standard with NAVISTEM B2000 control panel)

Regulator enabling:

- a burner to be run at one speed, two speeds or modulating
- Running a direct heating circuit
- Running two heating circuits or one heating circuit and a mixer valve protecting the heater in return temperature
- Running domestic hot water preparation
- Achieve a tile effect with one or more other boilers equipped with a SIEMENS regulator (LPB communication bus).

5.5. Cable set

On request, a set of cables with standardised 7 and 4 pin connectors (DIN 4791) can be supplied with the control panel, as well as the connection cable to defer burner failures. The burners used should be equipped with suitable connectors.

6. Installation guide

6.1. Boiler room and boiler room ventilation

The boiler room must be arranged in compliance with local regulations and installation specifications. Particular attention should be paid to the ventilation of the boiler room.

Supply of combustion air must be guaranteed (non-shut opening).

Minimum air requirement is 1.6 m³/h for each kW of boiler power.

Minimum free section of combustion air opening is 6 cm² for each kW of boiler power.

Important: The combustion air must not have high dust concentrations.

Furthermore, it must be free of halogens (chlorine and fluorine compounds). An excessive presence of halogen in the combustion air leads to great corrosion damage. The maximum permitted amount of halogen in the combustion air is 5 ppm.

Halogen compounds are found in spray cans, thinners, cleaning agents, degreasing agents and solvents, among others. In addition, halogen emissions are strongly suspected in the vicinity of dry cleaners', hair dressing salons, swimming pools, printing offices and washing machines installed in the same room.

In the case of doubt, the perfect quality of the combustion air must be ensured with an external air intake. Make sure that there is a minimum loss of pressure, since this could impair the performance of the burner.

6.2. Planning dimensions

6.2.1. Space required

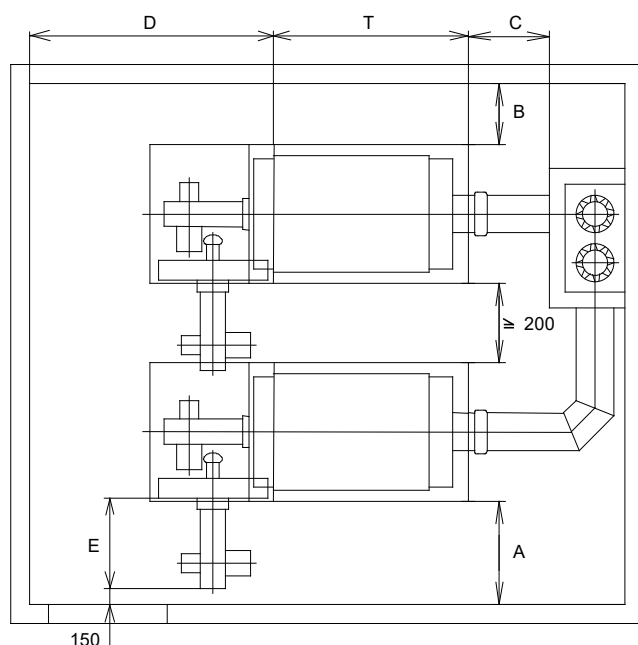

A It should be possible to open the furnace door, including burner, by 90°.

At least 200 mm of free space should be provided to the right and to the left of the boiler to install boiler casing.

B After installing the casing, the boiler can be moved closer to the wall, but at least 60 mm away from it.

C The boiler cleaning hole behind the boiler must be easily accessible and should be 600 mm away from the wall.

6.2.2. Boiler base

If the floor of the boiler room is moist or loose, a sufficiently high boiler base must be provided. Moisture does not go well with electrical equipment!

A base is also a good idea if the height is not sufficient for installing the burner. Otherwise, a boiler base is not required.

6.2.3. Boiler support

It is possible to mount the boiler on vibration dampers (available as option) to reduce noise transmission caused by vibrations.

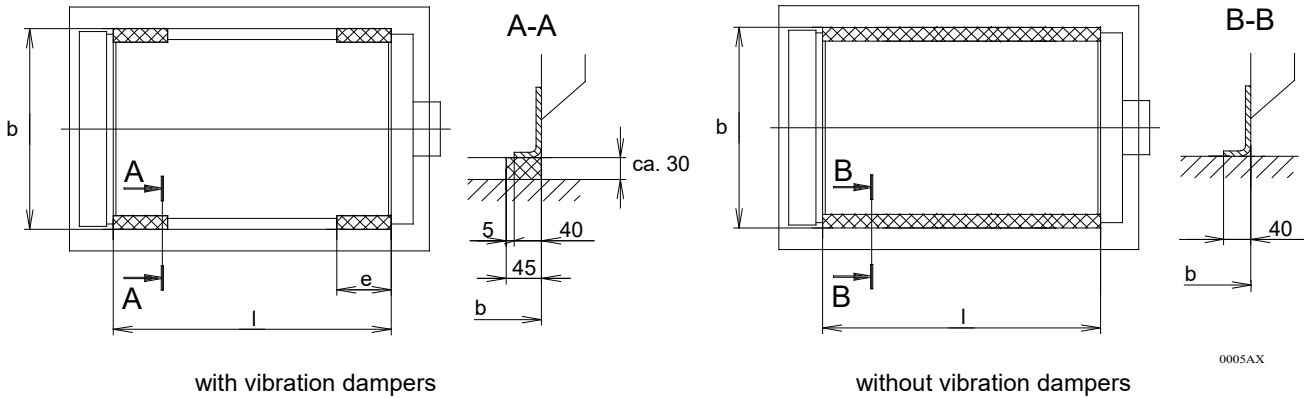

Pyronox LRP NT PLUS		1	2	3	4	5	6	7	8	9	10	11	12	13	14
Front and rear	D mm	1220	1220	1310	1310	1310	1310	1310	1310	1310	1310	1310	1600	1600	1600
Boiler block length	T mm	1015	1015	1155	1155	1355	1355	1335	1615	1615	1615	1615	1870	1870	1870
Boiler feet length	l mm	844	844	986	986	1186	1186	1186	1445	1445	1445	1445	1701	1701	1701
Boiler feet width	b mm	640	640	740	740	740	740	790	790	790	870	870	938	938	938
Vibration damper length	e mm	130	130	130	130	130	130	130	274	274	274	274	274	274	274

The mounting instructions for the silent blocks can be found in the separate assembly guide.

Afterwards, you can start installing the connection tubes on the water side.

Attention! Once the boiler is filled up, it will come down by further 2-3 mm.

6.3. Placement into the boiler room

The boiler can be placed in position in various ways:

The boiler is delivered on a wooden pallet that is suitable for a forklift truck, pallet roller or armoured rollers.

In addition, the boiler is equipped with a lifting eye and the boiler can be placed by means of lifting gear.

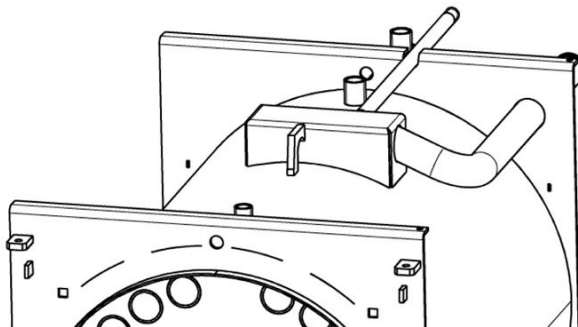

After positioning the boiler, the wooden pallet must be removed.

6.4. Hydraulic connection / technical safety measures

For the hydraulic connection of the heating system and water heaters– in particular with regards to technical safety devices such as safety valves, expansion tanks, etc. – refer to generally accepted engineering rules as well as locally applicable standards, specifications and regulations.

If boilers are installed in **garret-based heating plants** or at the highest point of the heating system, then boilers will have to be provided with additional safety devices (such as protections against water shortage). Observe the minimum operating pressure as specified in chapter 4.1. Act in compliance with local safety regulations in force at all times.

Before connecting the boiler to an old installation, it is necessary to flush the whole heating system. It is also recommended to provide for a sludge separator.

Boiler's maximum operating pressure and the maximum operating temperature are given in chapter 4.1.

No minimum level of the amount of circulating water is required.

Damage can occur from **corrosion** when oxygen continuously enters the heating water through open installations, expansion tanks that are too small, floor heaters with pipe material that is not oxygen-tight, etc. If this cannot be prevented, additional measures are necessary in the form of correctly used oxygen binding agents or chemicals. If it is not possible to realize an installation without oxygen entrance, a **system separation** must be set up using heat exchangers.

6.5. Electrical installation

6.5.1. General notice

The electrical installation must be carried out by an authorised electrician from beginning to end. In carrying out the electrical installation, local regulations as well as any standards and specifications in force must be complied with.

The wiring diagram is joined with the control panel.

Note: Electrical connections, especially the connection to the mains, should only be made after all other assembly and installation work has been completed.

Locally made installations (raceways, etc.) must not be clamped to the boiler's panel work!

6.5.2. Connecting to the supply mains

External supply is one-phase, alternate current type 230VAC, 50Hz, max. 16A or three-phase alternate current 400VAC, 50Hz, 10A. The apparatus is internally protected by a 6,3A delayed-action fuse (burner/boiler) and by an additional 6,3A delayed-action fuse for each additional governor or module.

All external connection cables must be laid to the back side of the boiler through the raceway under the boiler lid.

A DIN VDE 0116-compliant disconnecting device must be provided on site.

6.5.3. Connecting the burner

The electrical connections of the burner (power supply and control) are made by the customer in accordance with the requirements of the burner.

Depending on the order, burner cables with 7 and 4-position DIN4791 connectors are supplied. The burners that are used must be equipped with a corresponding counterpart.

6.6. Turbulators

Thanks to the turbulators, which are to be inserted in the smoke tubes, the combustion gas temperature can be controlled.

All smoke tubes in the third pass must equally be provided with turbulators. These smoke tubes are those that are open on the rear part, in the direction of the combustion gas collector. Also, read and follow the instructions in the assembly guide.

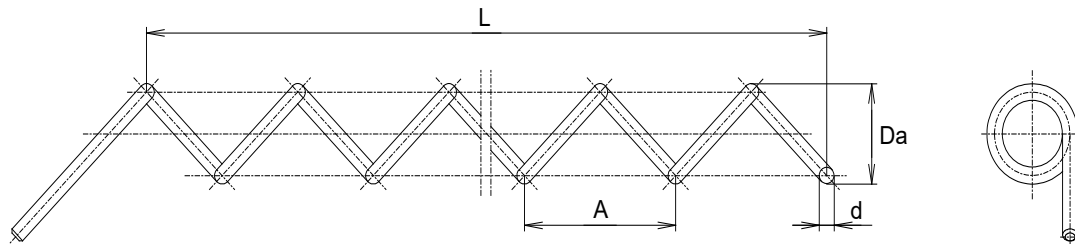

0007AX

Pyronox LRP NT PLUS		1	2	3	4	5	6	7	8	9	10	11	12	13	14
Number of turbulators		9	9	11	11	11	11	15	15	15	19	19	25	25	25
Outer diameter	Da	36													
Edge diameter	d	6													
Pitch	A	55													
Length	L	400	600	600	800	600	800	800	400	600	600	800	400	600	1000

6.7. Boiler control panel and casing assembly

Please refer to the separate assembly guide enclosed with the supply.

Attention: Mount the casing prior to connecting the unit to the flue!

6.8. Connecting the burner

6.8.1. Burner mating elevation / orientation possibilities

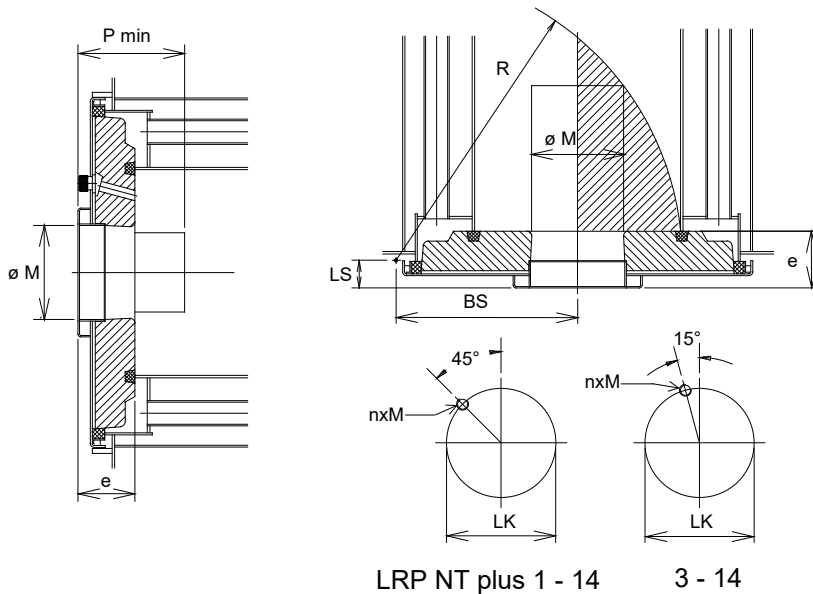

LRP NT plus 1 - 14

3 - 14

Model		1	2	3	4	5	6	7	8	9	10	11	12	13	14	
Furnace																
Lenght	L mm	768	768	910	910	1110	1110	1107	1366	1366	1366	1366	1618	1618	1618	
Diameter	D mm	342	342	415	415	415	415	463	463	463	508	508	530	530	530	
Burner connection																
Burner admittance diameter	M mm	140		190				212				290				
Burner tube lenght * min max (qN max) max (qN low NOx)	P mm	130				140										
		320				365				345						
		330		335		370		390		440						
Screw hole centre diameter	Lk mm	170		220				270				330				
		4 x M8, 45°		45°: 4 x M10 15°: 4 x M12				45°: 4 x M12 15°: 4 x M12								
Maximum door load from burner weight **	kg x m	20								34			60			
Burner orientation																
Max. swivel radius	R mm	470	470	545	545	545	545	605	605	605	665	665	713	713	713	
Distance boiler axle - pivot	BS mm	300	300	338	338	338	338	375	375	375	413	413	445	445	445	
Distance door flange - pivot	LS mm	45	45	45	45	45	45	45	45	45	45	45	45	45	45	
Door thickness	e mm	115	115	115	115	115	115	115	115	115	115	115	116	116	116	

09/06

* Burner tube lengths without consideration of an eventual intermediate flange

** Load as burner weight x distance burner centre of gravity - door. When necessary use a burner support.

6.8.2. Burner assembly

The front door is provided with a norm-conform flange for fitting the burner. An additional, intermediate flange may be necessary to fit the burner. The intermediate flange and relative screws must be supplied by the burner manufacturer.

Attention: The intermediate space between the burner tube and door hole must be filled with the supplied insulating material before the burner is commissioned (see separate assembly guide).

6.8.3. Connection to the fuel supply

The whole installation may only be carried out by a licensed installation company. The installation must be performed in accordance with local regulations.

Particular care is to be taken that measures are foreseen to prevent any burner start when the boiler door is open. Good practice is to connect the fuel supply to the burner in such a way that the supply line has to be

disconnected in order to be able to open the boiler door. Another possibility is to attach the burner cables with glands in such a way that the connectors on the burner have to be pulled to open the door.

Customer installations (oil tubes, etc.) must not be attached to the boiler casing!

6.8.3.1. Gas burner

Observe the separate instructions of the burner.

The gas installation must be dimensioned in accordance with the gas flow rate and the available gas pressure.

A shut-off valve must be installed in the gas supply line to the burner.

Important: Before the gas burner is connected to the gas line, it must be ensured that the line has been blown through and is free from particles and chips.

The gas line must be checked for leakage during commissioning and after each disconnection (leak detector spray).

The installation may only be operated using gas of the intended quality – observe burner type plate!

6.8.3.2. Oil burner

Observe the separate instructions of the burner.

6.8.4. Part load operation

Stick to the minimum power of the supply heat according the technical data, chapter 4.

6.9. Flue gas system

The pertinent rules of technology and good practice as well as the country-specific regulations and valid standards must be observed.

The Pyronox LRP NT PLUS boilers have been developed using the latest technologies. The perfect balance existing between boiler and chimney ensures optimal fuel use and economical system operation as a result.

6.9.1. Section determination

Sections must be calculated for boilers without draught.

Fuel type, power output, combustion gas temperature and quantity, chimney construction and height are all important elements in determining sizes.

6.9.2. Flue gas tubes

We recommend the use of flue gas tubes made from acid-resistant, non-corrosive materials. The tube must be laid and introduced in the chimney to an inclination of 30-45° to minimize pressure loss. The tube will have to be inserted in such a way as to prevent any condensation reversal from the chimney down into the boiler. To avoid vibration transmission, combustion gas tubes must be fitted with adequate sleeve tubes or clamps. Connections exceeding 1 m in length should be insulated.

At the same time, ensure that the measuring pipes extend beyond the insulation and that flanges and cleaning covers remain accessible.

The chimney must be designed so that it is gas and pressure-tight as well as moisture-insensitive and acid-resistant.

Attention: Mount the boiler casing prior to connecting the boiler to the flue (see chapter 6.7)!

7. Operating conditions

7.1. Fuels

The Pyronox LRP NT PLUS boiler is designed for operation with fuel oil EL and natural gas.

Attention: The use of other fuels such as for example biogas is only permitted with the express approval of the manufacturer.

7.2. Combustion air

The combustion air must not have high dust concentrations.

Important: Furthermore, it must be free of halogens (chlorine and fluorine compounds). An excessive presence of halogen in the combustion air leads to great corrosion damage. Make sure that no paints, thinners, cleaning agents, degreasing agents, solvents, chlorine containers, etc. are stored in the boiler room!

7.3. Filling the installation and water quality

The installation must be thoroughly rinsed before it is finally filled.

When filling for the first time and refilling, check the quality of the water in accordance with the values recommended in chapter 4.2. Poor water quality leads to damage in heating installations from calcification and corrosion. On the other hand, the service life, functional reliability and efficiency can be increased using appropriately treated water.

During the filling process, the circulation pumps should be switched off and all ventilating valves opened, so that the air in the system can completely escape. The filling process is finished when the operating pressure has been reached.

7.4. Protection against corrosion

Normally, no corrosion problems arise if systems are properly designed and installed and are run according to these instructions; consequently there is no need to use chemical additives. However, if water is of poor quality or if oxygen seeps from the air into the heating system (expansion chambers open, expansion/supply chambers too small, plastic tubes without diffusion blocking in floor heating) damages are something which cannot be completely excluded. If you happen to use chemical additives in your system, make sure that they are effective, harmless and above all appropriate for the materials your system is made of. Enquire with your chemical additive supplier.

In this case, you will need to arrange for a specialist water company to carry out annual quality checks on the water used in the heating system in order to avoid any damage to the system.

7.5. Requirements for operation

The maximum operating pressure and the maximum temperature to be observed are listed on the type plate. The minimum temperatures to be observed are given in chapter 4.1.

It is strictly recommended to maintain the boiler in operation during several hours after a cold start-up in order to evaporate condensates that are inevitably formed in any boiler during cold start-up.

8. Operation

Read this section of the manual with great care and get an installer to explain the heat producing system in all its different aspects: regulation and control.

If you suspect that the boiler or other part of the system is frozen, do not start the system.

Please also note the operating conditions described in chapter 7.

8.1. Commission

Before commissioning the system, please check:

- Whether the burner and the fuel system have been checked and the settings of the burner correspond to the required performance of the unit. Observe the instructions for putting the burner into operation.
- Whether any foreign matter has been removed from the boiler furnace
- Whether the turbulators have been properly installed (see sticker on boiler door or see chapter 6.6 of this instruction manual)
- Whether the clearance space around the burner tube has been filled with insulation material
- Whether the boiler door is closed properly
- Whether the heating system has been filled up with water and completely vented
- Whether the thermostats are properly regulated and whether the heating system governor has been set according to the necessary parameters by the support service or by the installer
- Whether the regulation and safety devices work properly
- Whether all shut-off valves (of both water and burner) have been opened
- Whether the circulation pumps work
- Whether the air supply is ensured and the flue outlet is free.

The unit is put in operation by actuating the ON/OFF switch on the control panel (I position).

8.2. Decommission

The unit is put out of operation by actuating the ON/OFF switch on the control panel (O position).

Should the heat producing system remain off for several weeks, we recommend that the following measures be taken:

- Close the fuel supply,
- Clean and protect the heating surface of the boiler. Your installation contractor will be pleased to give you some advice.
- In case of frost warnings, drain the system or add an anti-freeze product and follow the instructions given at 7.4.

8.3. First steps to take in case of failure

In the event of system operational failure, perform the checks in the table below. Also check the governor set-up. If the failure cannot be eliminated, call a reliable engineer or your support service.

Problem	Possible cause	Solution
Burner not functioning	No power	Check fuse, switch on main or safety switch. Connect supply and burner plug
	Burner LED is on	Press burner reset button
	No oil	Add oil
	Gas pressure insufficient	Call the gas board
	Overheat temperature LED is on. Safety thermostat has come into operation	Fix the cause, wait until temperature has dropped below overheat setpoint then reset the safety thermostat by pushing in the pin
	External default LED is on.	Fix the cause
Heating elements fail to heat up	Incorrect operation type setting on governor	Set up type of operation and heating programme
	Circulation pump blocked	Remove locking screw, turn shaft until no more resistance is left
	Water level or system pressure	Top up and ventilate
	Shut off elements on supply and return lines closed	Open

9. Maintenance

To maintain the high degree of efficiency of the unit, it is necessary to service it regularly. Depending on the type of operation, annual or semi-annual servicing is recommended.

The boiler and firing must be inspected by a qualified specialist in accordance with the official regulations.

Before performing any work on the unit, it must be disconnected from the mains and the fuel supply must be shut off.

The device contains components made of synthetic silicon mineral fibres (ceramic and glass fibres, insulation wool). In order to avoid all types of health hazards, suitable clothing and a protective mask must be worn for work on or with these components.

9.1. Periodical checks and maintenance operations

- Check manometer with circulation pump off. Low water or pressure level indicates that the system must be filled up with water.
- Check that the expansion chambers function properly
- Check safety valves as well as heating and hot water system blowers
- Carry out burner maintenance according to the recommendations given in the burner manual.
- Check fuel oil level
- Clean boiler and chimney

9.2. Boiler cleaning

Boiler should be cleaned by your chimney sweeper and engineer.

The cylindrical type construction of Pyronox LRP NT PLUS boilers makes cleaning much easier to perform. However, we recommend that heating surfaces in fuel oil boilers be cleaned with appropriate chemical products. Your installation contractor, as an engineer, will know how to best advise you.

- Turn off burner
- Disconnect burner plug from socket
- Loosen boiler door screws and rotate door together with burner till it stops.
- Remove the turbulators
- Clean the combustion chamber and smoke tubes
- Disassemble the lid on the back of the boiler and clean the flue gas collector
- Re-install the cleaned turbulators following the instructions given in chapter 6.6 of these instructions
- Re-install lid and close furnace door
- Start up burner again.

9.3. Burner maintenance

The regular maintenance of the burner (body, jet, burner head, igniter, pump filters) must be carried out by a qualified specialist in accordance with the instructions of the burner.

After the work has been completed, the settings of the burner must be checked to ensure that they meet the performance requirements of the boiler.

10. Spare parts

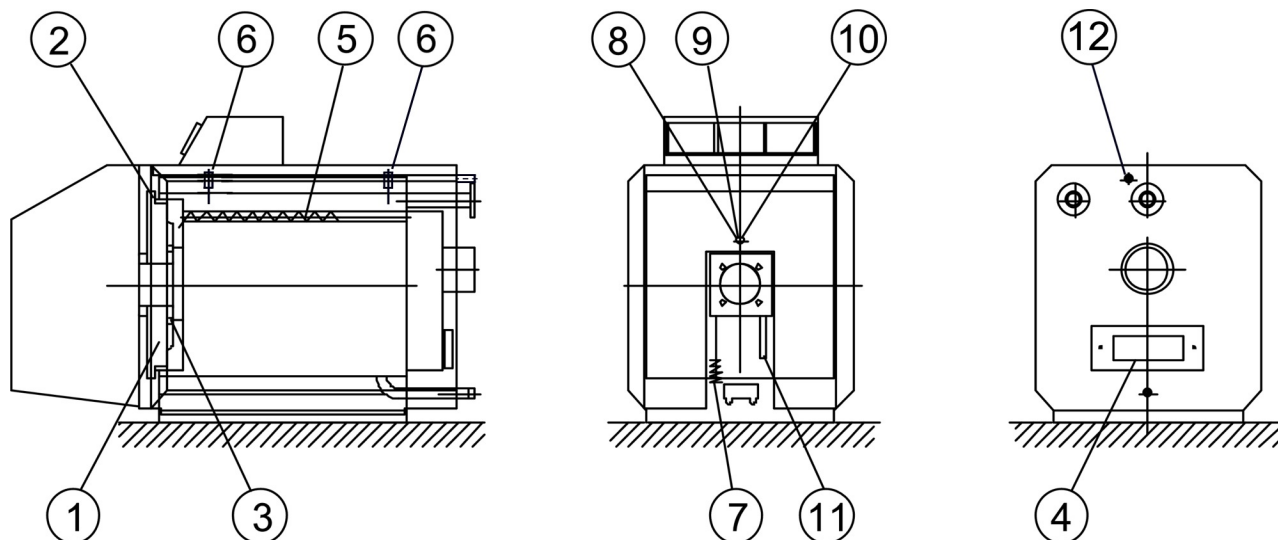

Pyronox LRP NT PLUS		1	2	3	4	5	6	7	8	9	10	11	12	13	14
Pos.	Spare part	Art. Nr.		Art. Nr.		Art. Nr.		Art. Nr.			Art. Nr.		Art. Nr.		
1	Ceramic insert for door	128059		128060		128060		128061			128062		128063		
2	Door outer seal 25 x 25 x length	113118 1850 mm		113118 2070 mm		113118 2070 mm		113118 2350 mm			113118 2600 mm		113118 2850		
3	Door inner seal 25 x 25 x length	113165 1110 mm		113165 1340 mm		113165 1340 mm		113165 1490 mm			113165 1550 mm		113165 1750		
4	Smoke chamber lid seal Ø 10 x length	113177 800 mm		113177 800 mm		113177 800 mm		113177 800 mm			113177 800 mm		113177 800 mm		
5	Turbulator Pieces	120283 9	122517 9	122517 11	120284 11	122517 11	120284 11	120284 15	120283 15	122517 15	122517 19	120284 19	120283 25	122517 25	409489 25
6	Thermostat sleeve LW 15 x 100	152385		152385		152385		152385			152385		153385		
7	Brush	120236		120236		120236		120236			120236		120236		
8	Nut for inspection window G 3/4"	120359		120359		120359		120359			120359		120359		
9	Inspection window Ø 23 x 4	120274		120274		120274		120274			120274		120274		
10	Inspection window seal Ø 24/20 x 1	113073		113073		113073		113073			113073		113073		
11	Door key	160230		160230		160230		160231			160231		160231		
12	Automativ vent valve 3/8" – KW17	409403		409403		409403		409403			409403		409403		