

Instruction Manual

COROLLA PACK 110-150

Installation and use

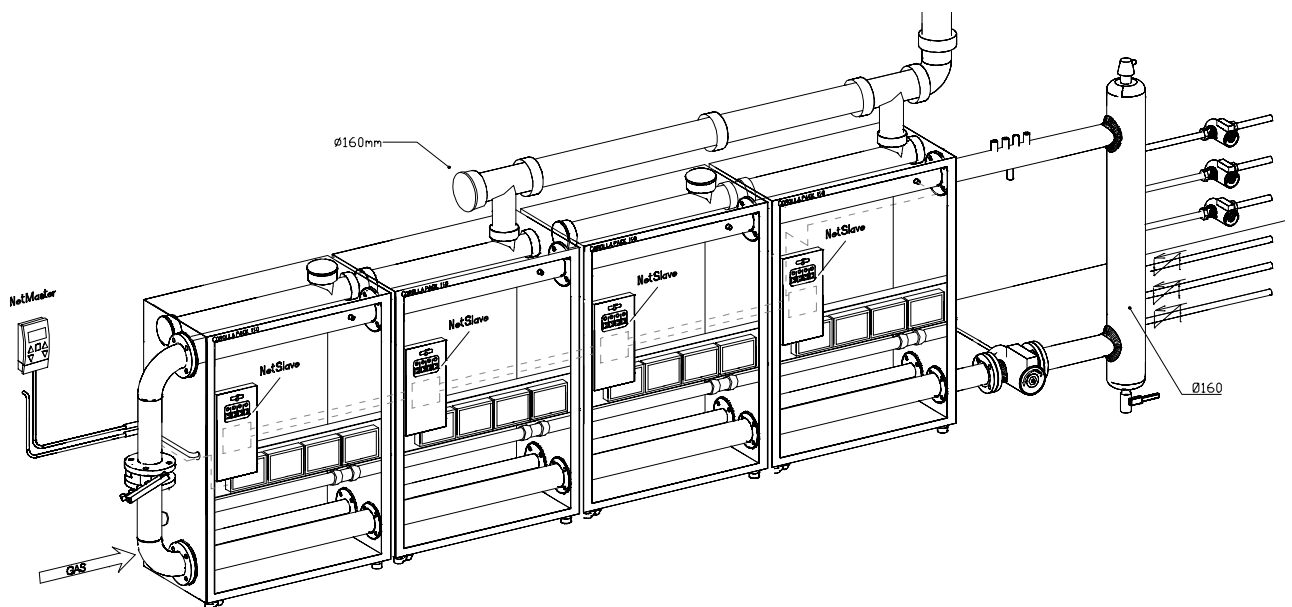

Index

Corolla Pack 110-150 features	3
System structure	4
Packaging and product identification	5
NetMaster use	6
Installation instructions	8
Water connections	9
ELECTRIC CONNENTIONS	11
POSITION FLOW PROBE	16
SAFETY DEVICES	19
Combustion product discharge	21
Dimensions	22
Installation drawing	24
Exploded view	27
Main components technical drawing	28
Electrical schemes	29
Technical data	31

Corolla Pack 110- 150 Features

Corolla Pack is a condensing, modular, pre-mixed, blown, thermal group; it is made up of a series of Corolla thermal elements installed in battery. The group, modulating from 10 to 1088 kW, offers the possibility to match until 29 thermal elements in cascade; each element is able to modulate from 9 to 37.5kW and it is equipped with the NetManager regulation with climatic function and serial bus RS485 link. The generator efficiency reaches 109% on Hi with integrated plastic flue manifold and continuous modulation of both gas and combustion air flow. Continuous modulation is also available (on demand) for the pump speed of each thermal element.

Corolla Pack thermal group, type 110 and 150, represents a point of arrival in terms of managing economy (efficiency up to 109% on Hi), reliability and flexibility. In fact, thanks to the new heat exchanger with improved power, to the new electronic management, to the modularity and versatility, which have distinguished Corolla Pack for more than ten years, it is possible to make a rapid connection to any kind of heating system and storage hot water production.

The new flue exhaust plastic manifold, whose diameter is just 125 mm wide, with socket end attack, placed inside the casing, allows to connect up to three Corolla Pack 150 in a series by using the same pipe. They also offer the possibility to place the discharge either on the right, left or upper side until 30 m high. The insertion of a single thermal element in cascade, over the traditional rotation of the ignition, can take place with variable factor of heating power load, so that when a certain power percentage of the first element is reached (e.g. 30%), the successive element already starts with the same load factor. This latter feature allows to share the power supplied inside more than one heat exchangers (eg. 40 kW divided into four exchangers) power/ exchange surface ratio which is particularly favourable for condensation latent heat. The main advantages of the new Corolla Pack can be summed up as follows:

- ✓ Blown air burner with total pre-mixing
- ✓ condensing heat exchanger with 109% efficiency;
- ✓ Input power from 10 to 150 kW (single Corolla Pack);
- ✓ Input power from 10 to 1088kW (Corolla Pack series);
- ✓ Connection until 29 thermal elements in cascade;
- ✓ 80°C maximum flue temperature;
- ✓ Plastic flue manifold⁽¹⁾ (PP self-extinguishing);
- ✓ Ø125 mm flue manifold up to three Corolla Pack in cascade;
- ✓ Flue exhaust until 30m⁽²⁾ Ø125mm with 450 kW power on Hs;
- ✓ Water manifold, condensate and smoke manifold inside the boiler;
- ✓ Quick connection of both water and condensate manifolds (with exit on the right and left side) and flue manifold (with exit on the right, left and upper side) ;
- ✓ RS 485 serial connection between the different thermal modules and the external board;
- ✓ Standard climatic regulation of the temperature with the NetManager system;
- ✓ modulating and modular regulation of the single thermal elements power;
- ✓ Automatic changeover (at adjustable time intervals) of the burners ignition order;
- ✓ Choice of the cascade insertion criteria of the burner (power %);
- ✓ Hot water and systems at a different temperature management , with or without priority;
- ✓ Winter/Summer automatic mode;
- ✓ Anti-legionella mode;
- ✓ hour and week programming schedule with " holiday program" ;

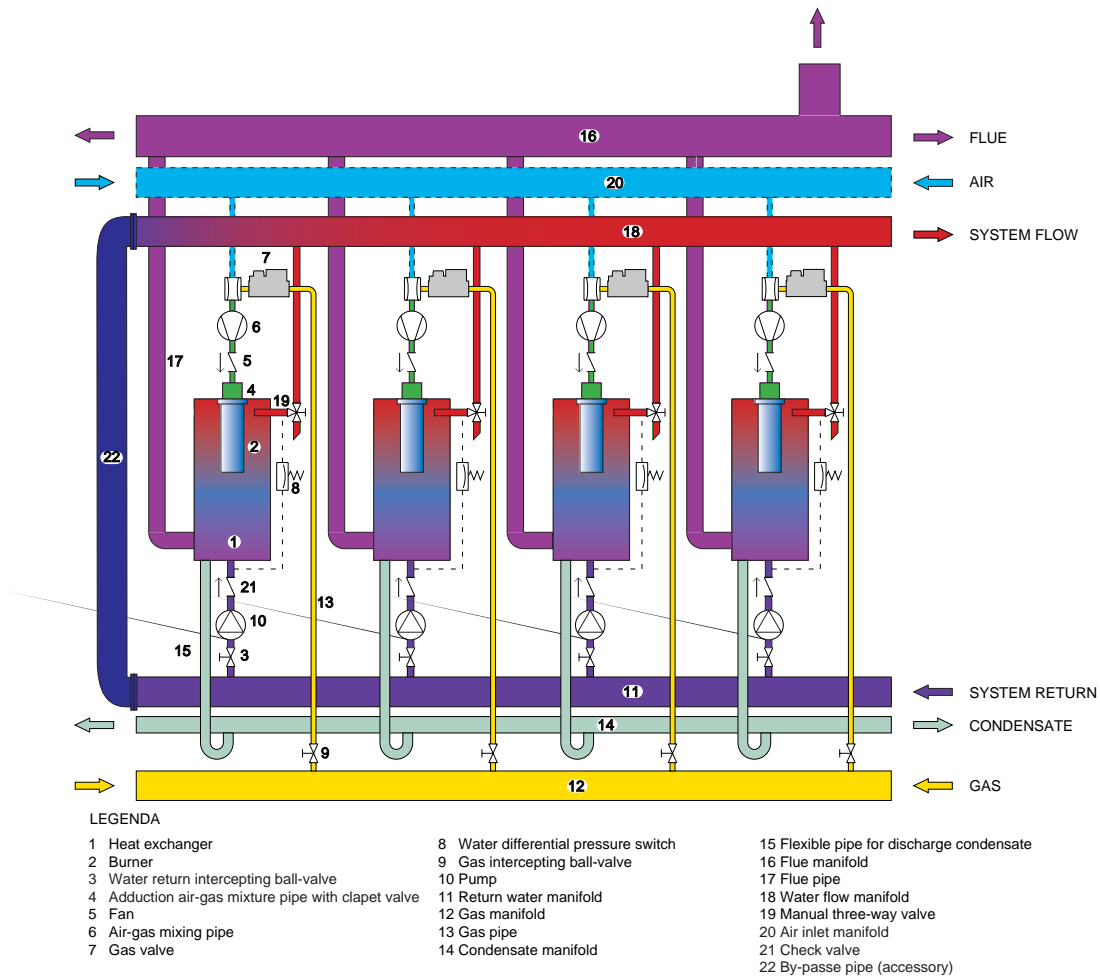

Fig. 1: Logic scheme- Pack 150

System structure

Corolla Pack is made up of a series of Corolla Thermal Units installed in battery placed inside a metal casing.

Each thermal unit is connected to the system in parallel position as compared to the others, through a flow , return, gas , flue manifold and condensated discharge manifold. According to the heat demand, the regulation system switches on and regulates the single thermal units in order to guarantee an optimal balance between power required by the system and power supplied by the boiler.

Each Corolla Pack can be serially matched up with other similar boilers, even with different power, in order to made modular heating thermal plants made up of several "casings" which shall be hydraulic connected and controlled by a single modular boiler integrated inside each single single Pack.

This regulation system has many advantages: maximum exploitation of the condensation technology, excellent modularity of each single boiler and of the whole the battery ones, ratio of the system modulation equal to 1:125 in order to cover any power range from 9 to 1088 kW. All these features contribute to maximize the economy of the condensing boiler and to allow an excellent system-boiler matching.

The thermal element turning off is followed by the turning off of the slave pump so that pressure drops are minimized when the burner is off and a correct water flow is ensured inside the hydraulic system.

The ignition order of each single burner is fully managed by a microprocessor logic device which ensures an equal number of working hours to each thermal unit.

Packaging and product identification

Corolla Pack boilers are delivered on pallets, they are packed and protected with a strapped carton. It is important to check the integrity of the product and the correspondence with the order. Product's features are indicated outside the packaging, i.e.: type, power, version, combustible. In case the product differs from your order, please contact the point of sale immediately.

The boiler's packaging contains the following items:

- n°2 caps Ø 125mm mounted on the upper, right flue outlet;
- n°2 caps Ø 50mm mounted on the condensate discharge manifold;
- n°1 cap l=80mm mounted on the upper flue outlet (for stainless steel version only);
- n°1 gasket Ø 125mm mounted on the upper outlet (for stainless steel version only)
- n°1 pipe with hose nipple mounted on the thermal unit for the system outlet

The boiler is available into the following versions:

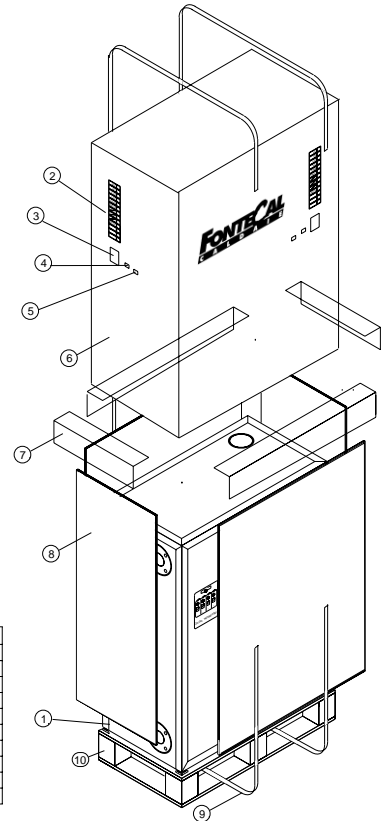

N°	DESCRIZIONE
10	Pallet
9	Strap
8	Polystyrene protective panel
7	Reinforcement
6	Packaging
5	Serial number label
4	CE label
3	Warning label
2	Boiler type label
1	Corolla Pack

Fig. 2: Corolla Pack packaging

Code	Description
4 060 20 4 03	PACK 060 DN80 NATURAL GAS
4 060 20 3 03	PACK 060 DN80 NATURAL GAS INOX
4 060 20 2 03	PACK 060 DN125 NATURAL GAS
4 060 20 1 03	PACK 060 DN125 NATURAL GAS INOX
4 060 20 8 03	PACK 060 DN80 LPG
4 060 20 7 03	PACK 060 DN80 LPG INOX
4 060 20 6 03	PACK 060 DN125 LPG
4 060 20 5 03	PACK 060 DN125 LPG INOX
4 075 20 4 03	PACK 075 DN80 NATURAL GAS
4 075 20 3 03	PACK 075 DN80 NATURAL GAS INOX
4 075 20 2 03	PACK 075 DN125 NATURAL GAS
4 075 20 1 03	PACK 075 DN125 NATURAL GAS INOX
4 075 20 8 03	PACK 075 DN80 LPG
4 075 20 7 03	PACK 075 DN80 LPG INOX
4 075 20 6 03	PACK 075 DN125 LPG
4 075 20 5 03	PACK 075 DN125 LPG INOX
4 110 20 4 03	PACK 110 DN80 NATURAL GAS
4 110 20 3 03	PACK 110 DN80 NATURAL GAS INOX
4 110 20 2 03	PACK 110 DN125 NATURAL GAS
4 110 20 1 03	PACK 110 DN125 NATURAL GAS INOX
4 110 20 8 03	PACK 110 DN80 LPG
4 110 20 7 03	PACK 110 DN80 LPG INOX
4 110 20 6 03	PACK 110 DN125 LPG
4 110 20 5 03	PACK 110 DN125 LPG INOX
4 150 20 4 03	PACK 150 DN80 NATURAL GAS
4 150 20 3 03	PACK 150 DN80 NATURAL GAS INOX
4 150 20 2 03	PACK 150 DN125 NATURAL GAS
4 150 20 1 03	PACK 150 DN125 NATURAL GAS INOX
4 150 20 8 03	PACK 150 DN80 LPG
4 150 20 7 03	PACK 150 DN80 LPG INOX
4 150 20 6 03	PACK 150 DN125 LPG
4 150 20 5 03	PACK 150 DN125 LPG INOX
4 110 40 4 03	PACK 110 DN80 NATURAL GAS GB
4 110 40 8 03	PACK 110 DN80 LPG GB
4 110 40 2 03	PACK 110 DN125 NATURAL GAS GB
4 110 40 6 03	PACK 110 DN125 LPG GB
4 150 40 4 03	PACK 150 DN80 NATURAL GAS GB
4 150 40 8 03	PACK 150 DN80 LPG GB
4 150 40 2 03	PACK 150 DN125 NATURAL GAS GB
4 150 40 6 03	PACK 150 DN125 LPG GB
4 110 30 2 03	PACK 110 DN 125 HONG KONG TOWN GAS
4 150 30 2 03	PACK 150 DN 125 HONG KONG TOWN GAS

CE 0085 1998 ★★★★★ (IT)

Fontecal Spa
65012 VILLANOVA (PE)
-ITALIA-

Year of Manufacturing: **02 07 0576**

Serial Number: **02 07 0576**

Product code: **4 150 20 4 03**

COROLLA PACK 3" natural gas

Category: 2H₃ Type B23,C33X,C53X
N. CE certificate type 0085AQ713
Monophase electric supply 230V 50Hz 580 W

Supply	Type	Pression	Setting
Natural Gas	G20	20 mbar	X
L.P.G.	G31	37 mbar	
	G30	30 mbar	

Nominal Heat input (kW): Hi= 135,0 Hs=150,0
 Efficiency 100% load 80-60 °C = 97,0
 Efficiency 100% load 50-30 °C = 108,3
 Efficiency 30% load 80-60 °C = 99,4
 Efficiency 30% load 50-30 °C = 108,6
 Primary water maximum temperature: 80 °C
 Water primary pressure: max 5 bar, min 0,5 bar
 Water maximum pressure (kg/h) = 22

Net Master use

The Net Master display allows to set all the functions related to the regulation of one or more Corolla Pack thermal modules.

The regulation system consists of a Net Master display (fig.b) and of one or more NetSlave units installed inside the Corolla Pack (display in fig. a). NetSlave modules display is made up of 6 LEDs which indicate the status (ON or OFF) of the connected exits.

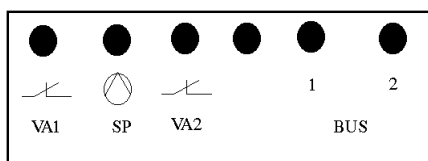

fig. a: NetSlave Display

VA1 Main Pump
 SP Tank pump
 VA2 Programmable exit 2
 Bus1-2 Flashing according to the signals transmitted

Netslave connecting strip and their relative connections are shown in paragraph "electric connections". The Net Master regulator disposes of two entry levels: the first level is addressed to a basic user and enables him to set the desired heating temperature and water standard, whereas the second one allows to set the main system parameters. This manual will show the functions related to the first level.

Regulator switching on.

Once power has been supplied to the Pack of reference (see paragraph "serial connections") the NetMaster will display the software version. This sign shall disappear after the starting procedures are completed and if no system failure rises. If there is no Bus connection, the system switches to the basic general display. This display will be visualized till you pass on to other settings or if further information are requested.

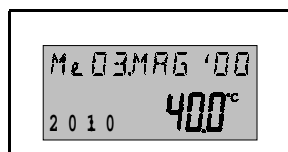



fig. a1: Basic general Display

Continuous heating mode with pre-scheduled timing (chimney sweeper function)

This function implies continuous heating supply

over a pre-scheduled time interval of 30 minutes. All the system's boilers work under the maximum temperature set on the Service level. In this case cascade conditions do not apply. The following scrolling sign is displayed:

MISURAZIONE EMISSIONI
 VALORE NOMINALE 80 GRADI

In order to enter this function, press  for about 2 seconds. The display remains still for the whole time and after 30 minutes or if the function is disactivated, the regulator will switch back to its normal functioning mode with the basic display.

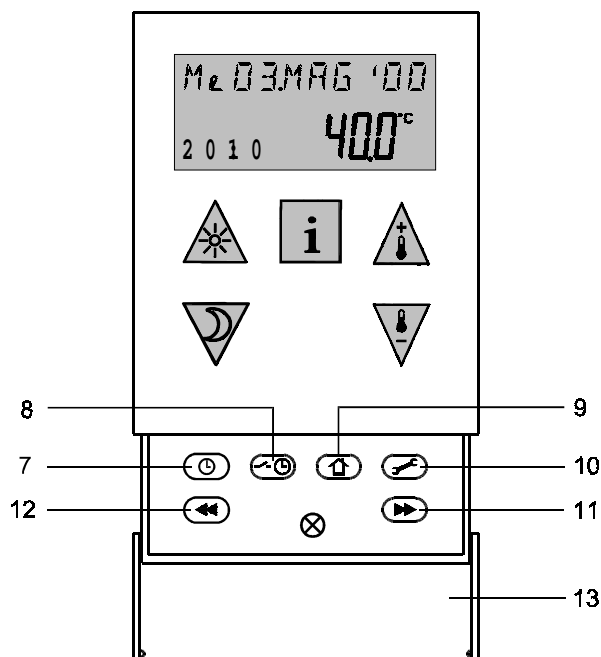





fig.b: NetMaster Regulator

Continuous Heating mode

This function implies continuous heating supply at normal temperature without considering the regulator time programs. Flow temperature is adjusted according to the temperature set (set-point) on the parameters level of the building. In order to activate this function, press  until COMFORT is displayed. After about 3 seconds, you get automatically back to the previous display. With the basic display, the symbol  shall start flashing. To escape this mode, go back to the automatic functioning or step to another functioning mode.

Automatic heating mode

Press  till the sign AUTOMATICO is displayed in order to enter the automatic heating

INSTALLATION AND USER MANUAL

mode with temperature time programs.

Standby mode

This mode implies the complete switching off but with anti-freeze protection still on. In order to activate it, press  till STANDBY is displayed. To escape, go back to the automatic functioning.

Continuous reduced mode







This function implies continuous heating supply at reduced temperature without considering the time programs of the regulator. Flow temperature is adjusted according to the delivery value set on the parameters level of the building. In order to activate it, press  till RIOTTO is displayed.

After about 3 seconds, you get automatically back to the previous display and the flashing symbol  shall be displayed. To escape, go back to the automatic functioning or switch to another type of functioning.



Information about the installation (basic display)

All the installation real values can be read in succession on the display. They have just an informative purpose and do not effect the regulation functions. Once said display as been chosen, it will become the basic one. The information level differs for two ranges: the overall installation one and the one related to the different stages. Enter the information level by pressing , at first the general range will be displayed:

IMPIANTO
INFO 00

1. Press  to enter the general range of the boiler. Information can be obtained by pressing  in succession. The button  allows to scroll back the signs. Press  to go back to the basic display.
2. Use  and  to write the identification number of one thermal element within the battery (unit) e.g.: for the first boiler.

GRADINI
INFO 01

Press  to enter the range. Information can be obtained pressing  in succession. The button  allows to scroll back the signs. To go back

to the basic display, press .

Display for installation data

All the real values of the installation can be read on the display.

To enter this level, press .

to scroll the parameters :  forward

 backward

values displayed

- Total number of boilers
- Number of boilers working
- Total system modulation
- Flow set temperature
- Real flow temperature
- Water flow set temperature + offset.
- Real water flow temperature of the tank
- Sanitary water set temperature
- Real sanitary water set temperature - probe1
- Real sanitary water set temperature - probe2
- Heating circuit watch ACCE/SPEN
- Sanitary circuit watch ACCE/SPEN
- Circulating pump watch ACCE/SPEN

For further information about the Net Master system use and programming, see the manual supplied with the regulator.

Installation instructions

Corolla Pack thermal modules are made up of 3 or 4 thermal elements which are common to all the boilers belonging to the same family and they have a thermal power of 27 kW (Hi) or 33.75 kW (Hi). The modules can be installed in cascade according to the power required by the installation and they can reach a maximum of 29 thermal elements¹.

The grouping of more than one modules allows to make some noiseless thermal plants, with low thermal inertia and high power in a very simple and rational way.

Find below a list of powers and configurations available:

No. of modules for each Corolla Pack	Single element power (kW)	Corolla Pack input power kW (GHV)	Corolla Pack input power kW (NHV)
2	30	60	54
2	37,5	75	67
3	37,5	112,5	102
4	37,5	150	135

Table 1

Each thermal module is equipped with the following connections which have been pre-set for the connection to the system:

Please note that superior and inferior water manifold are available with diameter 3" or 5", according to the power of the Corolla Pack battery installed and to the relative water flow.

MANIFOLDS	DIMENSIONS	NOTE	CONNECTION TYPE
upper water manifold	3" - 5"	- system inlet	} Flanged manifolds for an easy connection to the system
lower water manifold	3" - 5"	- system outlet	
gas manifold	3"	- gas supply can be connected to both ends of the gas manifold at the same time.	
air manifold	110 mm	- for airtight seal installations	} socket end manifolds for an easy realization of the flue system using plastic pipes ² .
condensate manifold	50 mm	- to connect to the sewer system	
flue manifold	125 mm	- see tab. 2.2 for the connection of more than one Pack unit	

Choose the diameter of the water air and flue manifolds according to the flow rate that goes through the battery (see following scheme).

description	unit of measurement	up to 450 kW (GHV)	between 450 and 1088 kW (NHV)
Water manifold	inches	3	5
Flue manifold	mm	125 (included into the boiler)	one circuit for each 450 kW [3]
Air manifold	mm	110	110 [4]
Gas manifold	inches	3	3
Condensate manifold	mm	50	50

Table 2

¹ A set of 29 thermal elements can be achieved, for instance, installing no.5 Corolla Pack 150 and no.3 Corolla Pack 110.

² As for the plastic material utilization, follow the rules in force. Particularly, EN 677, DIN 4705, UNI CIG E01.08.925.0 and rules related to them.

³ See recommended installation schemes on the manual appendix.

⁴ Please contact the Technical Dept. of Fontecal S.p.A. for the dimensioning of the air manifold, in case of input power greater than 450 kW, with air manifold connected outside the boiler room.

INSTALLATION AND USER MANUAL

Follow the procedure below to install the thermal groups:

WATER CONNECTIONS

1. After unpacking the boiler/s, establish the output direction of the water, gas and condensate pipes (eg.: left or right connection). Also establish the modality and the position of both the flue manifold and the eventual air manifold (in case of installation with outside air intake). It is recommended to take into account the electric connections (230 V supply) of the thermal group too (see paragraph ELECTRIC CONNECTION). The dimensions of the several manifolds

are reported in table 2; dimensions might vary according to the power installed. Please note that each pipes connection to the system can be indifferently made at the right or left side of the thermal group.

However, it is suggested to follow one of the scheme of installation reported on this manual.

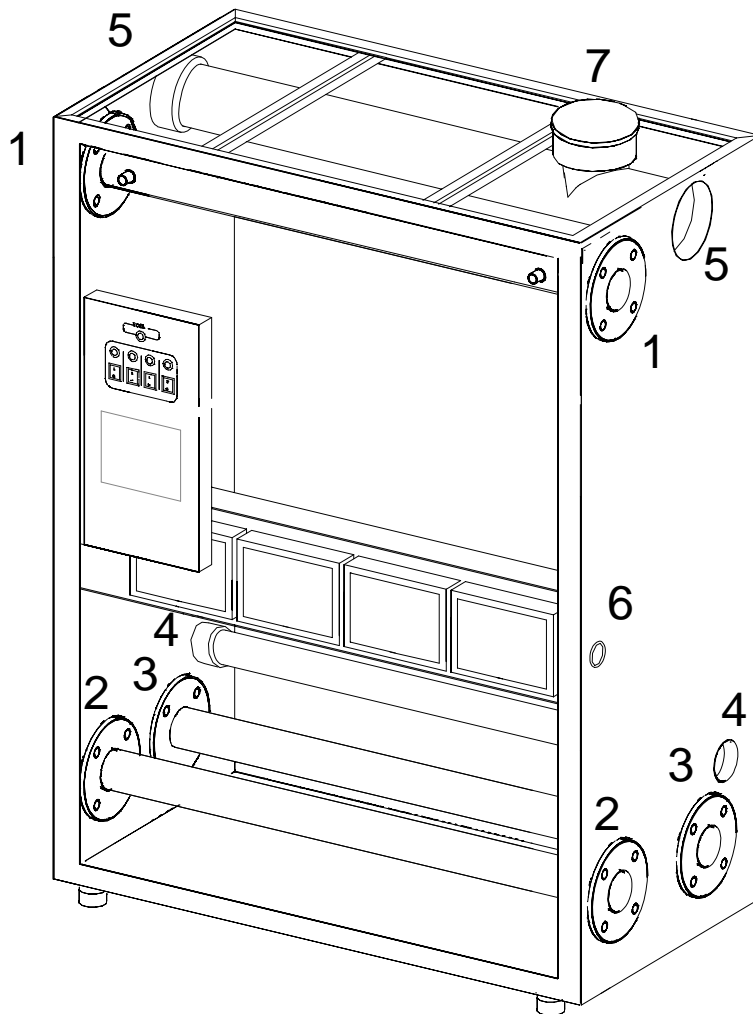

-
- 1 Water flow system
 - 2 Water return system
 - 3 Gas manifold
 - 4 Condensate manifold
 - 5 Flue manifold
 - 6 Serial electric connection
 - 7 Alternative flue manifold
-

Fig. 3

2. Place the thermal group/s near the inlet and outlet pipes of the system. The groups can be installed either with right or left outlet of water, air, smokes, condensate, gas pipes (e.g.: air inlet on the right, water outlet on the left, gas on the right). The position of each Corolla Pack inside the area of installation can vary according to specific requirements of space or to the type of the installation itself (e.g.: leaned against the wall, back-to-back, etc.); in any case, make sure that same necessary space is left for the passage of the electric supply cables of each Corolla Pack and to let the front panel open. Space is also required in case of maintenance services of the flue, condensate, and gas pipes.

INSTALLATION AND USER MANUAL

3. Mount the side panels of the Corolla Pack and connect the first (or the only) thermal group of the battery to the system, use the correct connections and carefully avoid any sudden variation of section among the piping of both the boilers and the system. If necessary, adjust the boiler's feet height to level the frame of the boiler and to open the doors easily .
4. Once water connections between the first group and the system have been made, connect successively the other eventual thermal groups to the first one, following the advice above.

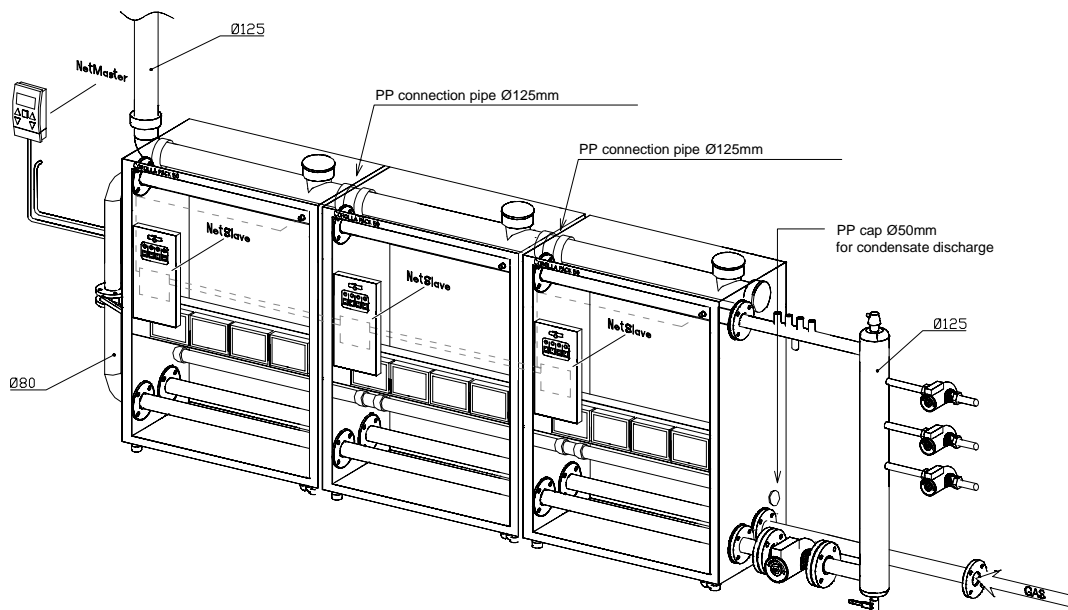

The connections between the socket end flue manifolds of the single Corolla Pack, until a maximum of 450kW on Hs (e.g.: n° 3 Corolla Pack 150), can be made by means of piping sections male/male \varnothing 125 mm in polypropylene of about 15 cm length. Analogously , use sections male/male \varnothing 50 mm of about 13 cm length to connect the different condensate discharges. **See table 2 to choose the diameter of the different pipes.**

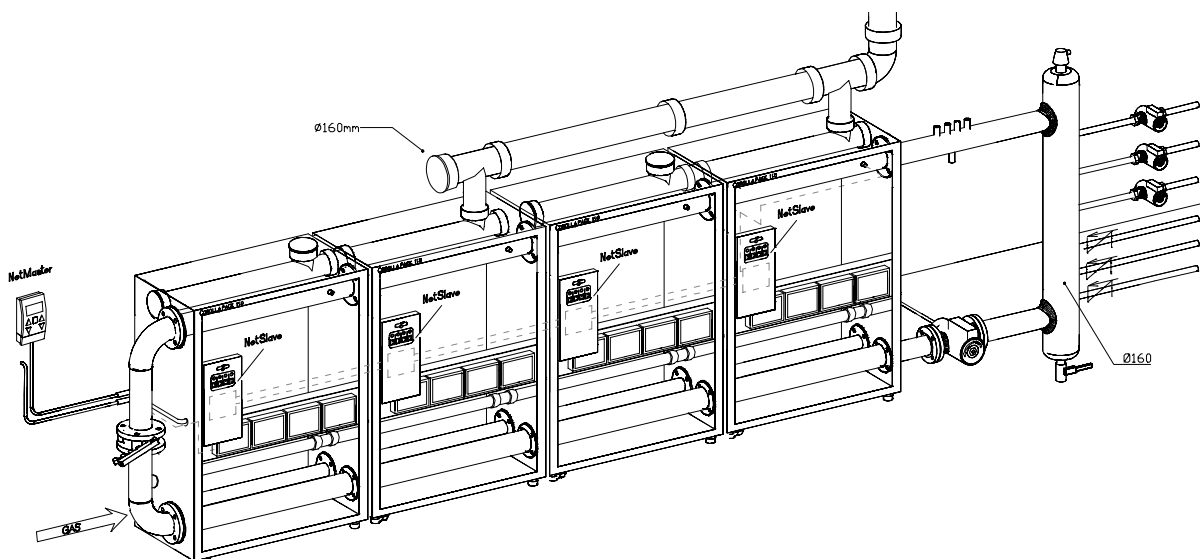

INSTALLATION AND USER MANUAL

If the installation overcomes 450 kW on Hs, use a 5" water manifold, also use a flue manifold for smokes outlet like the one reported on the previous figure (Ø 160 mm). Flanges and blank flanges for water and gas pipes can be easily found in the market (see denomination on the price list). A ricirculation pipe with or without regulation valve is foreseen to connect the two water manifolds. The recirculation pipe can be separately requested, as a spare part, in proportion of one piece for each group or more then one group mounted in battery.

5. Connect the eventual recirculation (by-pass) to the last group of the battery or lock out the manifold with some blank flanges in order to realize one of the suggested schemes.

ELECTRIC CONNECTIONS

Single Pack Installation

The following electric connections have to be made on the thermal group:

Supply 230V AC. The connection has to be made according to the current rules about electric safety, with a multi-polar sheathed cable. The cable has to be properly protected against humidity, abrasions and accidental contacts with L+N+G system.

Connect the power supply cable to the twin disconnecting switch which is placed behind the control panel of the boiler. In order to accede to the switch, dismantle the metal sheet protections unscrewing the screws of connection.

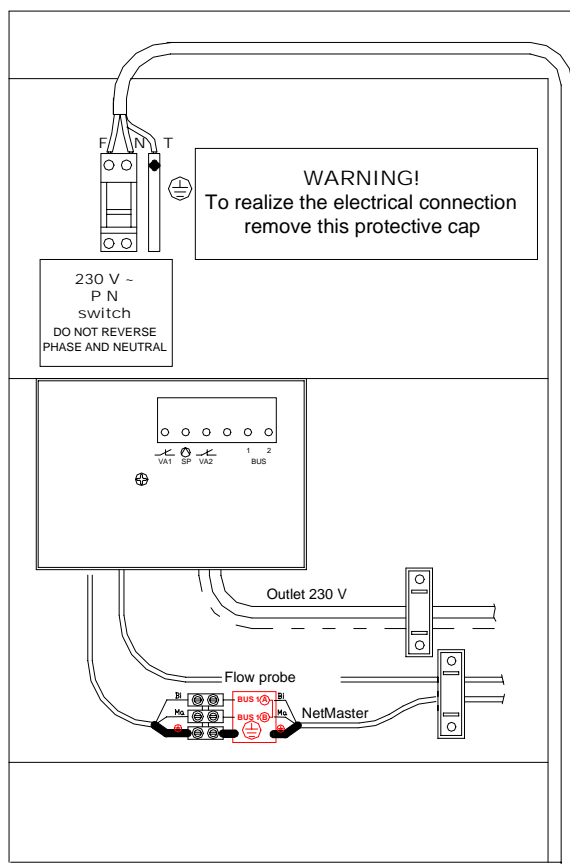

Fig. 4: Real view of the electric panel

The protection conductor (ground) has to be connected to the ground general connecting strip placed next to the switch (see picture on the side).

OTHER CONNECTIONS

Other electric junctions have to be made on the connecting strip inside the NetSlave board; the terminal is placed at the rear side of the control panel, below the disconnecting switch (see picture on the side).

In order to accede to the connecting terminal, remove the cap that protects the Netslave board and unscrew the screw on the front part of the board itself, below the cap. Once the front part of the board has been removed, the general connecting terminal is accessible, see picture below on the following page. The connecting strip is divided into two parts i.e. "230 V" and "LOW VOLTAGE" so that the circuit with different volatage is better separated and any accidental contact or radio-interference is avoided.

INSTALLATION AND USER MANUAL

Connect the following devices to the low voltage part:

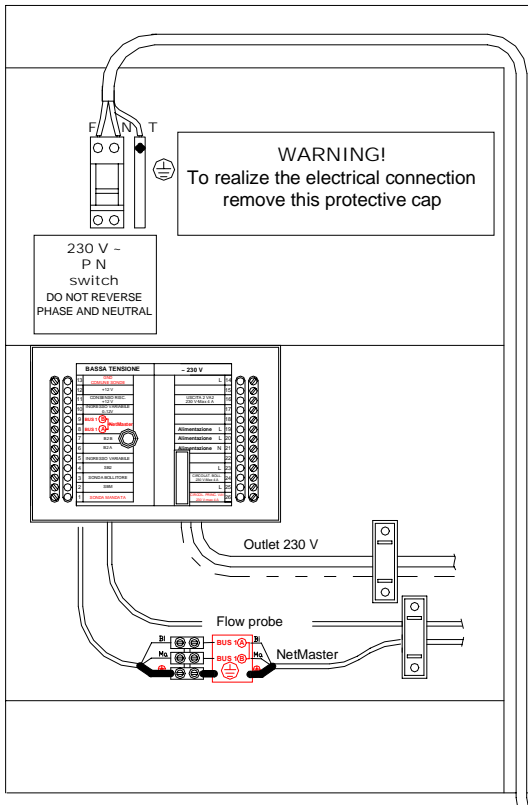

Fig. 5: Real view of the electric panel and connecting strip (box dismantled)

FLOW PROBE. The component is supplied in low voltage, for this reason carefully avoid any closeness to 230V wires for both safety reasons and to avoid any dangerous radio-interference. The probe cable, including the 6 m sheathed cable, is supplied with the Net Master regulation kit. the probe cable has to be connected to contacts N° 13 (probes shared contact) and N° 1 (flow probe).

NetMaster DISPLAY

The connection with the display has to be absolutely made by a twice shielded cable. The shielding must be connected to the ground by one end. The display has to be connected to contacts N° 8 and N° 9 . While connecting the display, mind not to invert contacts A (8) and B (9). ATTENTION! The two conductors are already connected to contacts A (8) and B (9), the new cables will have to be connected together with the already existing ones.

HOT WATER TANK PROBE (if present)

The connection is a low voltage one and it has to be made through the cable supplied with the probe (available on demand) between contact n° 3 (hot water tank probe) and n° 13 (probes shared contact) according to the modalities reported on the previous point.

LOW VOLTAGE		~ 230 V	
13	GND PROBES SHARED CONTACT		L 14
12	+12 V		15
11	HEATING CONTACT +12 V	CONTACT 2 VA2 230 V-Max 4 A	16
10	VARIABLE CONTACT 0÷12V		17
9	BUS 1 B		18
8	BUS 1 A NetMaster	Power supply	L 19
7	B2 B	Power supply	L 20
6	B2 A	Power supply	N 21
5	VARIABLE CONTACT		22
4	SB2		L 23
3	HOT WATER TANK PROBE	HOT WATER TANK PUMP 230 V-Max 4 A	24
2	SBM		L 25
1	FLOW PROBE	MAIN PUMP VA1 230 V-max 4 A	26

Fig. 6: NetSlave connecting strip (dismantle the box to accede it).

ADDITIONAL CONTROLS

Two additional contacts for external devices additional control are available.

The first one, to connector 11, allows to activate the heating function when powered with a +12 V tension is drawn from connector 12. This control is usually disabled .

The second one can be used for the connection to a modulating signal 0 - 12V from an external device.

INSTALLATION AND USER MANUAL

The following devices can be connected to part of the connecting terminal reserved to the 230V connections:

MAIN PUMP

The connection has to be made with a sheathed wire linked to connector n° 26 of the connecting strip. Neutre and Ground can be linked to connecting strip relative contacts of the boiler. Pay particular attention to the pump absorption, **if the absorption is higher than 4A** (resistive load), interpose a suitable power **contactor** between the board and the pump.

HOT WATER PUMP (if present)

The connection has to be made with a sheathed cable linked to connector n° 24 of the connecting strip. Neutre and Ground can be connected to the relative contacts of the connecting terminal of the boiler. Pay particular attention to the pump absorption, if the absorption is higher than 4A (resistive load), interpose a contactor of suitable power between the board and the pump.

PROGRAMMABLE CONTACT (optional)

A programmable contact is available on the board over the ones used for heating and sanitary pumps. Connection above, placed by contact n° 16 of the connecting strip, named OULET 2, can be configured in several ways (generic alarm of external signal, supplementary pump, etc.) by setting the Net Master board properly.

It is recommended not to connect loads higher than 4A directly to the connecting terminal without interposing a power contactor.

OUTDOOR PROBE

The outdoor probe has to be connected to the connecting strip reported on the figure that follows the two connectors indicated with SE.

The connecting strip is placed on the left side of the boiler, inside the board rack. The cabling of the outdoor probe has to be made with a shielded cable (the shielding grid must be connected on the Ground at one extremity).

Probe wires can be inverted on the connecting terminal provided that they are connected to connectors SE.

ROOM THERMOSTAT

Connectors X and Y can be found next to contacts SE, reported on the previous point, they can be used for an eventual connection of a room thermostat. **ATTENTION!** If the contact between the two connectors is shut by a jumper, the thermal elements of the boiler shall work in heating function.

Therefore, if the water temperature of the system is below the set-point, the thermal elements activate themselves.

The main electric connections are reported on scheme E01, E02, E03, E04.

ELECTRIC CONNECTIONS

Corolla Pack cascade installation

Supply 230 V AC. Each module (boiler) must be electrically powered. The connection has to be made with a multi-polar shielded cable according to the current rules about electric safety. The

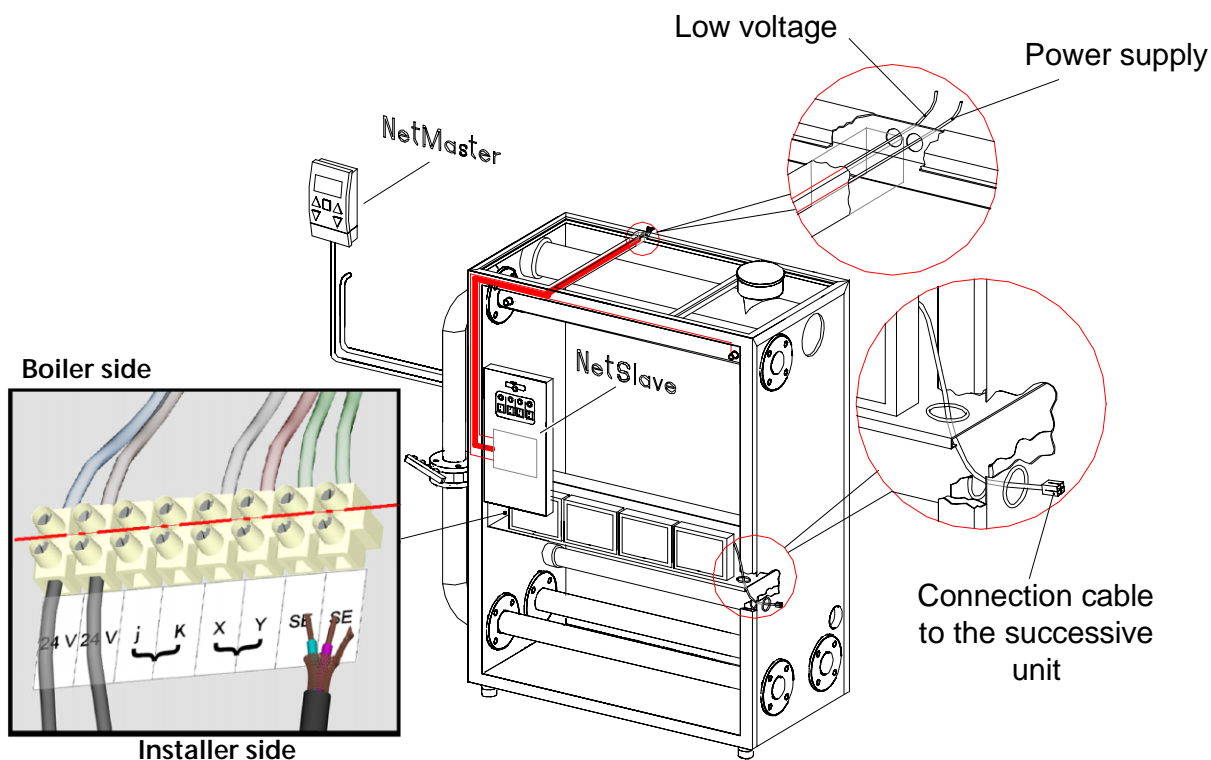

Fig. 7: Outdoor probe contacts and connection to the successive unit .

cable must be properly protected against humidity, abrasions and accidental contacts, with L+N+G system.

The electric connection has to be made for each module as described in paragraph "Single Pack installation" .

OTHER CONNECTIONS

Individuate the **reference Pack** inside the battery.

The **reference Pack** is the closest one to the system inlet. As a consequence, the length of the pump cables, of the inlet probe and of the eventual hot water tank probe, shall be reduced. Low and High voltage connections must be exclusively made on the **reference Pack** as described on paragraph "Single Pack Installation". Follow all the instructions described on paragraphs above ("FLOW PROBE", "DISPLAY NetMaster", "HOT WATER TANK PROBE") while making the connection on the **reference Pack**. The All the Pack of the battery must be connected through a serial wiring which is already preset on the different modules and contained inside the board rack. The connection shall start from the **reference unit** of the battery; unroll the cable highlighted in the figure, pass it through the preset fairleads and connect it to the relative wiring of the successive Pack by using the proper connector.

Pack position	Hierarchic Order	NetMaster address
1°Pack of the battery	Reference Pack	Address 1
2°Pack of the battery	Auxiliary Pack	Address 2
3°Pack of the battery	Auxiliary Pack	Address 3

Tab. 3: addresses configuration of a three Pack battery

INSTALLATION AND USER MANUAL

Once the connection has been made, all the Pack of the battery will be as follows:

1. electrically powered;
2. connected to each others through a serial wiring;
3. connected to the probes, to the pump and to the NetMaster display through the reference Pack.

In order to complete the electric installation, select address of the board itself on the higher side of the NetSlave board of each termal group.

The address can be selected by twisting the arrow of the indicator untill the number corresponding to the position of the unit inside the battery is reached.

The reference Pack must necessary indicate address 1.

Pay particular attention selecting the address 1 on the reference Pack.

Example: three units cascade.

1° Pack of the battery	reference Pack	address 1
2° Pack of the battery		address 2
3° Pack of the battery		address 3

Find below a short list for electric connections:

Reference Pack or single Pack			
connection type	description	wires no.	notes
Power supply 230V~	1 Power supply	3	Line-Neutral-Ground
	2 Main pump	1(line)	Neutral and Ground shared
	3 Hot water pump (if available)	1(line)	Neutral and Ground shared
	4 Programmable connections	/	see connecting terminal
Low voltage electrical connections	a outdoor probe	2	supplied with the NetMaster kit
	b NetMaster visualizer	2	use a shielded cable
	c Flow probe	2	supplied with the NetMaster kit
	d hot water tank probe *)	2	available on demand
	e Available controls	/	see terminal strip
	f Serial bus connection to the successive units	4	pre-wired into the boiler

*) For big storage tanks it is available an additional intermediate temperature probe to be connected to the relative contacts

Other boilers connected the reference one			
connection type	description	wires no.	notes
Power supply 230V~	1 Power supply	3	Line-Neutral-Ground
Low voltage electrical connections	a Serial bus connection to the next units	4	pre-wired into the boiler

POSITION OF THE FLOW PROBE (ON THE FLOW MANIFOLD)

Each unit upper water manifold is equipped with two pockets where the temperature probe has to be inserted. The latter probe continuously checks the flow temperature of the heating circuit.

Either you are installing a single pack or a battery of them, the flow probe, supplied with the NetMaster kit, must always be installed inside the pocket placed downstream, as it is shown on the picture above.

Of course, in case of more than one Pack in battery, the probe must be inserted in the pocket placed downstream on the unit closer to the system inlet.

If prescriptions reported on the previous paragraph have been followed, the reference Pack shall be the closest one to the system inlet. As a consequence, the inlet probe will directly start from the control panel on the boiler on which the probe has to be installed.

The temperature difference read by the probe causes ignition, switching off and modulation of all the thermal elements in cascade.

Installer shall take care to place the probe inside the pocket which is closer to the system inlet, in accordance to the water stream. The two possible solutions are shown on the figure reported on the previous page.

Corolla Pack thermal group is made up of more than one basic elements; which are common to all the boiler of the family and they are matched and contained inside a metal casing.

Such thermal groups (modules) have been studied in order to be easily assembled one with the other, in this case it is also possible to realize high power central thermal plants in an easy and rational way.

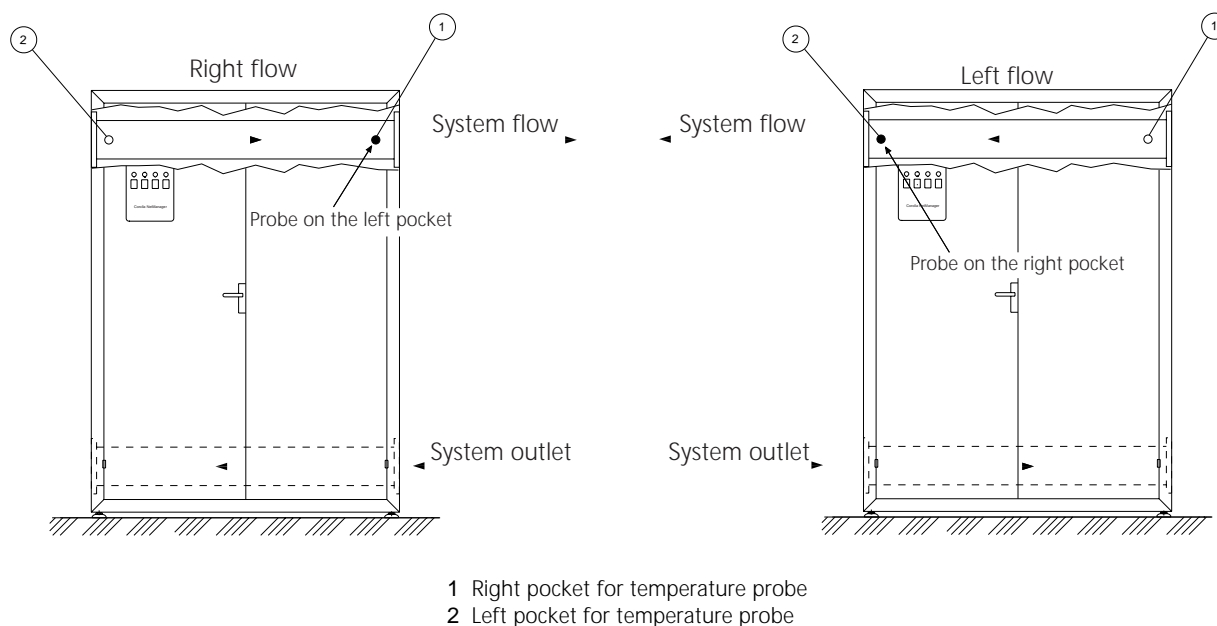

Fig. 8: Installations of the flow temperature probe on the single Corolla Pack manifold

INSTALLATION AND USER MANUAL

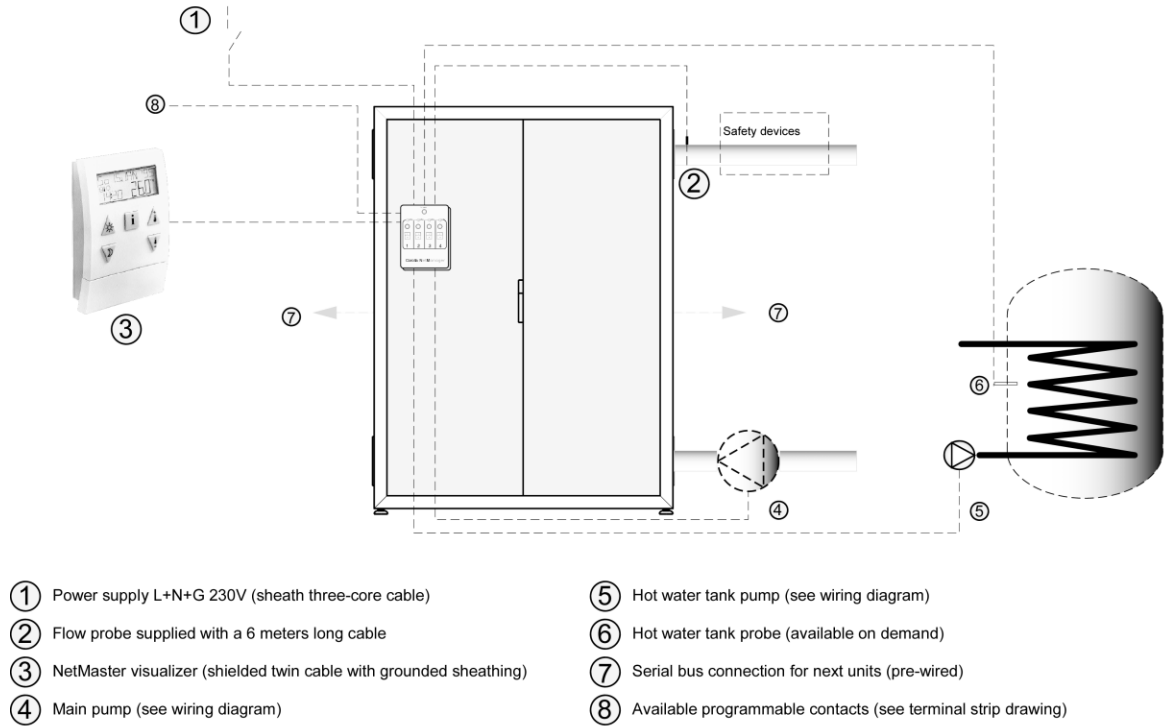

Fig. 9: Electrical logic scheme - 1 unit Corolla Pack with water tank

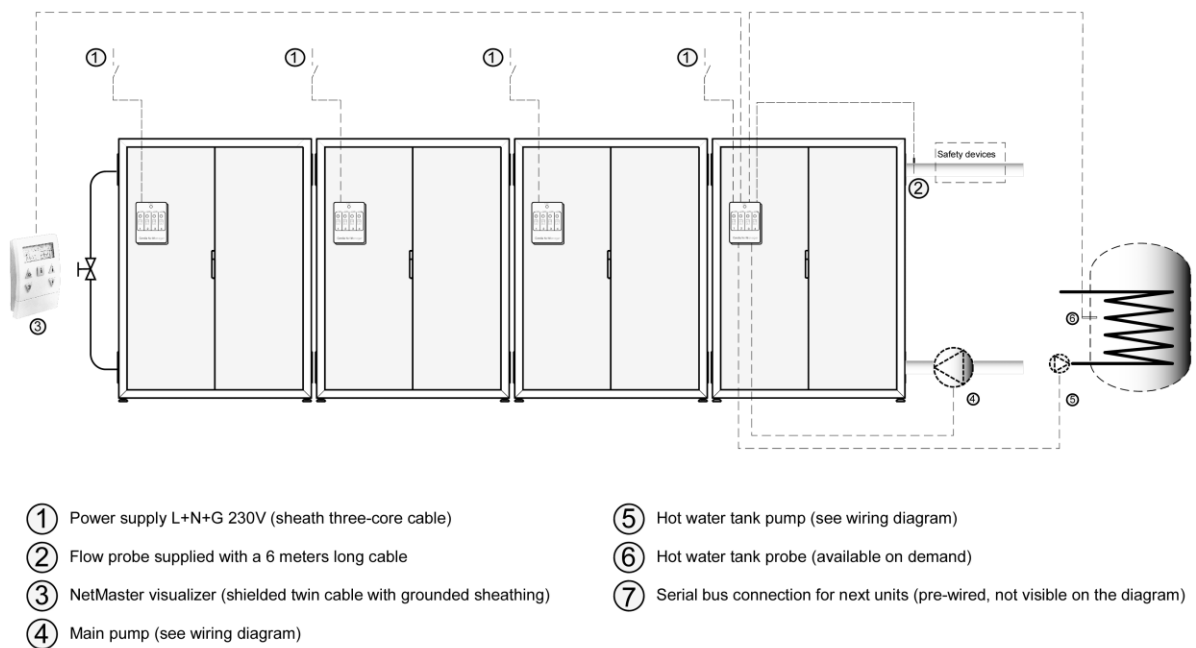
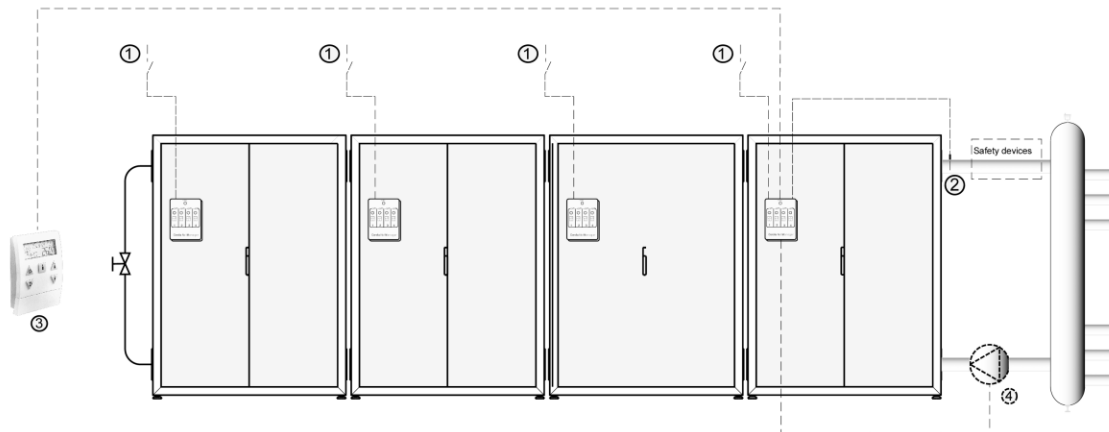

Fig. 10: Electrical logic scheme - 4 units Corolla Pack with water tank

INSTALLATION AND USER MANUAL



- ① Power supply L+N+G 230V (sheath three-core cable)
- ② Flow probe supplied with a 6 meters long cable
- ③ NetMaster visualizer (shielded twin cable with grounded sheathing)
- ④ Main pump (see wiring diagram)
- ⑤ Serial bus connection for next units (pre-wired, not visible on the diagram)

Fig. 11: Electrical logic scheme - 4 units Corolla Pack connected with main pump

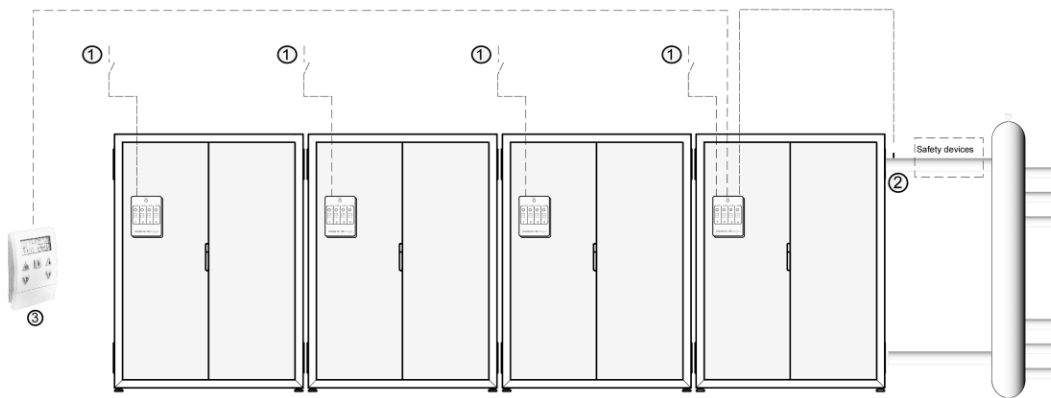

- ① Power supply L+N+G 230V (sheath three-core cable)
- ② Flow probe supplied with a 6 meters long cable
- ③ NetMaster visualizer (shielded twin cable with grounded sheathing)

Fig. 12: Electrical logic scheme - 4 units Corolla Pack connected with flow probe

INSTALLATION AND USER MANUAL

SAFETY DEVICES

All the functions of the thermal module are electrically controlled. Any anomaly causes the lock out of the single thermal element and the automatic shut down of the gas valve.

The following devices are installed on the water circuit:

- Autoreset safety thermostat for for each thermal element
- Safety fluxostat (water differential pressure switch) for each thermal element
- Temperature probe on each thermal element flow and return. Probes are managed by an electronics homologated for safety performances and with a double processor technology. Such device allows to continually control both flow temperature and the Dt between flow and return of the battery element.
- Modulating flow temperature regulation for both single elements and the whole battery

The following devices are installed on the combustion circuit:

- Gas electrovalve in B+C class for each thermal element, with gas flux pneumatic compensation according to the inlet air flow (air/gas 1:1 ratio)
- Ionization electrode for continuous flame detection
- Flue pipes temperature control for each thermal element

Both protection interventions and gas valve shut-off occur, on each thermal element, when the following situations take place,

- Flame extinguishing
- exchange circuit overheat
- Flue high temperature
- air flow reduction

Corolla Pack boilers are pre-arranged for the battery matching up with other thermal modules included within Corolla Pack range having different power as well.

Thanks to the modularity, it is possible to make some compact and flexible thermal plants up to 1088 kW.

Hot water thermal plants with a global boiler power higher than 35 kW are subject to the ISPESL Institute's R Collection, therefore we enclose the specific declarations referred to modular heat boilers required by the new ISPEL R Collection, edition 2000, in course of approval.

INSTALLATIONS WITH MODULAR BOILERS

(ref. Chapter R.12 R Collection, ed. december 2000)

1. Generalities and definitions

- 1.1. Corolla Pack is a modular boiler which is made up of one or more thermal modules pre-arranged by FONTECAL S.p.A. to work singularly or in battery and connected to a single water circuit by a double manifold (i.e.: one return and one flow manifold);
- 1.2. Corolla Pack boiler is made up of 2, 3 or 4 inseparable thermal elements;
- 1.3. One Corolla Pack thermal element consists of an heat exchanger, a burner and its relatives control devices;
- 1.4. Fontecal S.p.A. pre-arranges the Corolla Pack boiler for the battery matching up. Each single thermal module is supplied together with the following items:
 - working drawing with all the electric and mechanic components of the whole boiler;

INSTALLATION AND USER MANUAL

- dimensions and connections in order to provide proper functioning and safety, as foreseen by the manufacturer lay-out(see installation instructions in the technical appendix).

2. Protection devices

(Omissis...).

3. Flux circulation

3.1. The flux minimum flow of each single thermal module is controlled by both a water differential pressure switch, installed inside each thermal element and by a safety electronic system which continually and simultaneously controls a sharp temperature probe, installed on the water flow and return pipe of each single thermal element. Each thermal element is equipped with its own pump, separated from the rest of the circuit and it is subject to the burner functioning with post-circulation after the burner turning off. Therefore, water delivery is linked to the power of the element itself. A three way intercepting device is placed on each element water circuit, in fact the system meets the Collection prescriptions as far as it is the following concerned:

- The thermal element capacity is not higher than 5l, in compliance with the conditions stated on issue 3.2.2 of the R Collection;
- Heat supply is interrupted in case of insufficient water flow thanks to a device installed on the thermal element;
- Although the thermal elements' capacity is lower than 5l, an intercepting device (three way valve) is installed in order to allow the communication of the element with the atmosphere before the interception phase.

3.2. Points 3.1 and 3.2 achievement is guaranteed by a Manufacturer's - FONTECAL S.p.A.- declaration

4. Boilers not pre-arranged by the Manufacturer

Corolla Pack boiler is pre-arranged by the manufacturer in order to be installed in battery and all the documentation supplied and the homologation certificates achieved (e.g.:DVGW, GASTEC, etc.)are EXPLICITLY referred to such kind of installations.

Combustion products discharge

Corolla Pack boilers have been homologated with flue exhaust pipes made of self-extinguishing PP or with materials in compliance with the EN 677, DIN 4705 and other related rules.

The diameters of the pipes foreseen by the discharge system are reported on the table below.

All the listed diameters refer to polypropylene, self-extinguishing pipes (class B1), made with socket-end pipes or similar ones which have been homologated together with the Corolla thermal modules. Said pipes can be supplied on demand with the boilers by Fontecal S.p.A.

The maximum equivalent length of the flue discharge pipes, including the eventual intake pipe (installation Type C), is equal to 45 m with a maximum head of 2m for each 90° elbow. Each module is pre-set for three female, socket-end attacks D 125mm for the combustion products discharge at the right and at the left, on the upper door of the thermal module. The flue discharge pipe can be indifferently connected to one of the three attack in order to make one of the suggested schemes. The picture below shows the position of the three socket end attacks D 125 for the flue exhaust.

Max power (kW)	L max equivalent (m)	Diameter (PP) (mm)
≤ 450 kW	42 m	125
> 450 ≤ 900	42 m	2 x 125 or 1 x 160
> 900 ≤ 1088	42 m	3 x 125 or 1 x 200

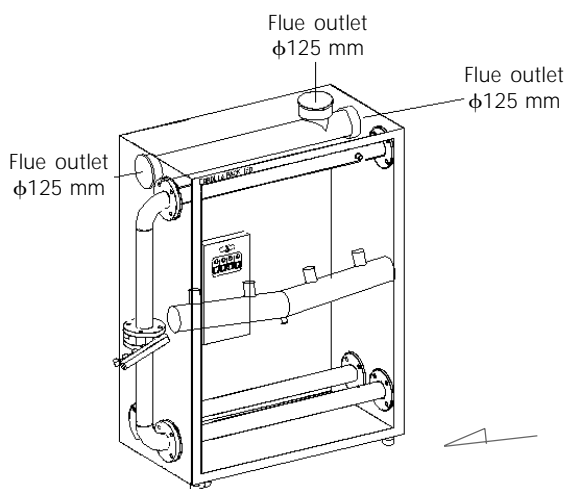

Fig. 13: Flue outlets position

Pressure drops of the elbow

The 90° elbow pressure drops are equal to 2m. The table above refers to plastic materials (self-extinguishing, polypropylene). On the contrary, for metal materials use a normally sold diameter which is closer, for excess, to the ones listed above.

WARNING!

In case of installations with room air intake, (either inside the heating thermal plant or outdoor), do not obstruct the air flow below the metal casing.

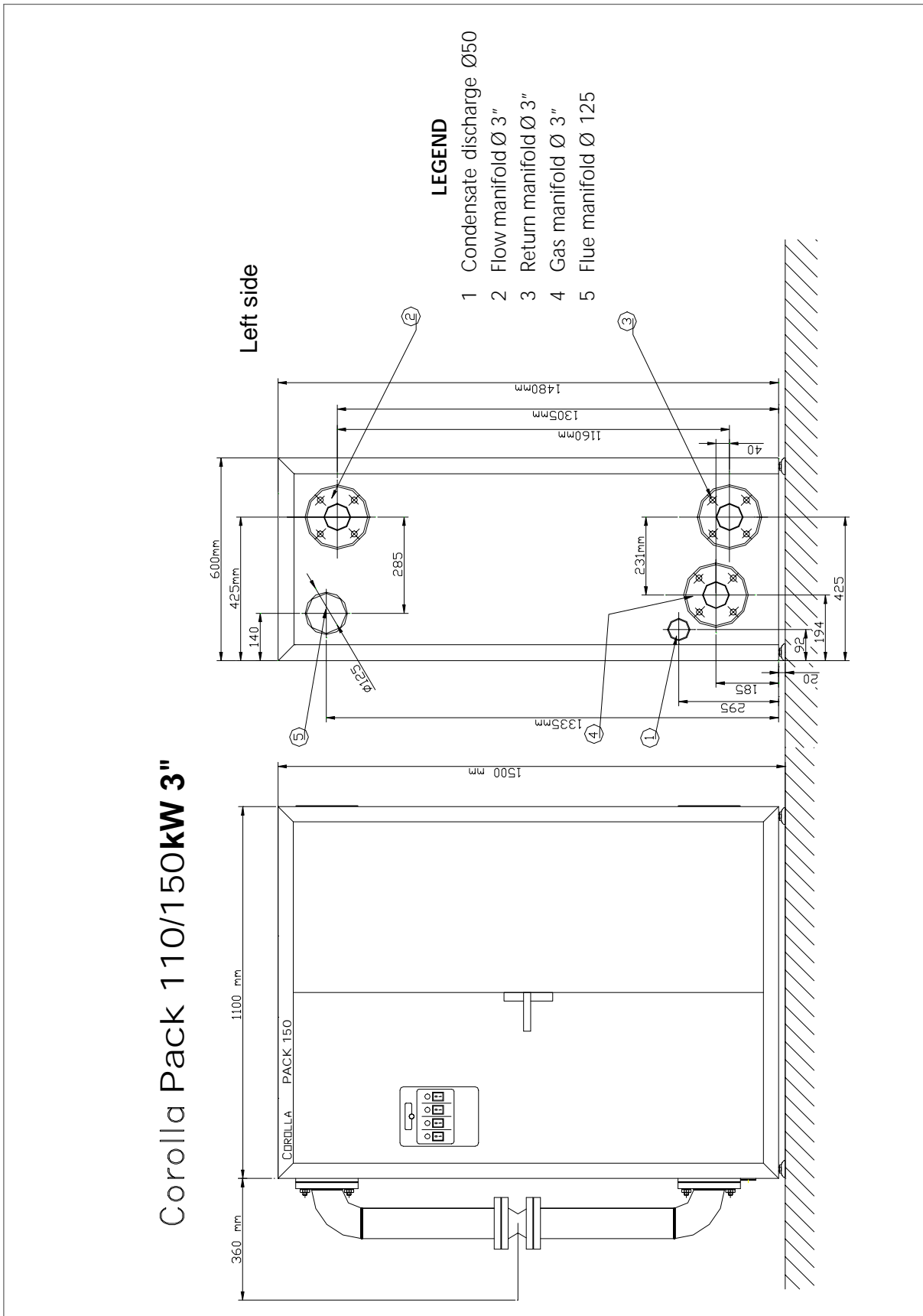

Fig. 14: Corolla Pack 110/150 dimensions. 3" flow and return manifolds

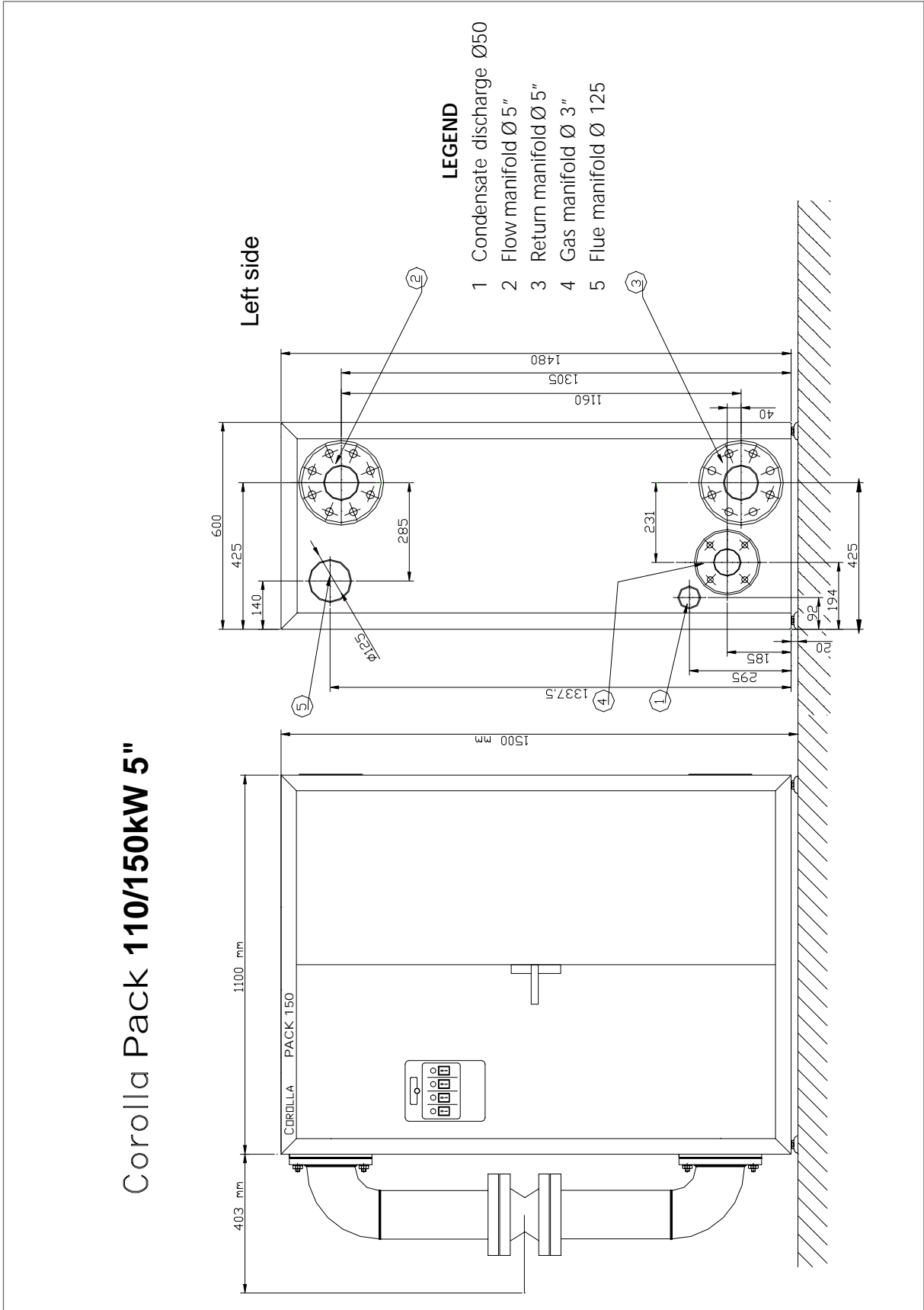
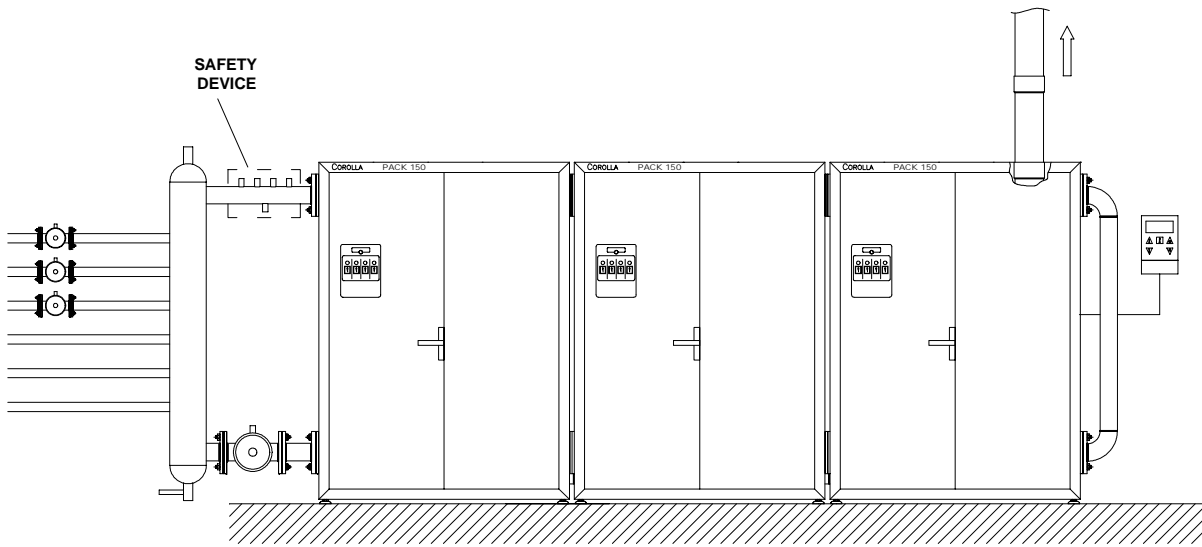

Fig. 15: Corolla Pack 110/150 dimensions. 5" flow and return manifolds

Installation drawings (examples)



Scheme A

Battery of 3 left side connection Pack with Polypropylene flue pipe Ø 125 and safety device position.

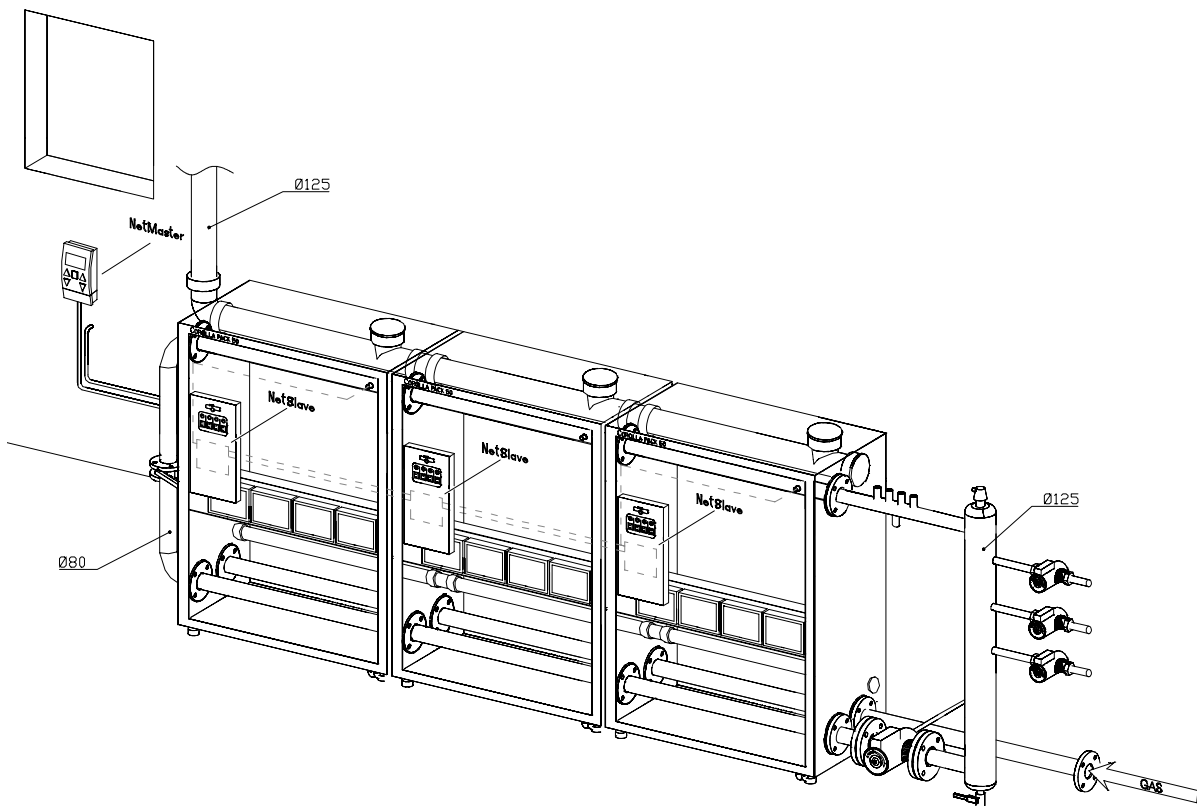

Scheme B

Battery of 3 Pack with left flue pipe, right gas connection and NetMaster connection

INSTALLATION AND USER MANUAL

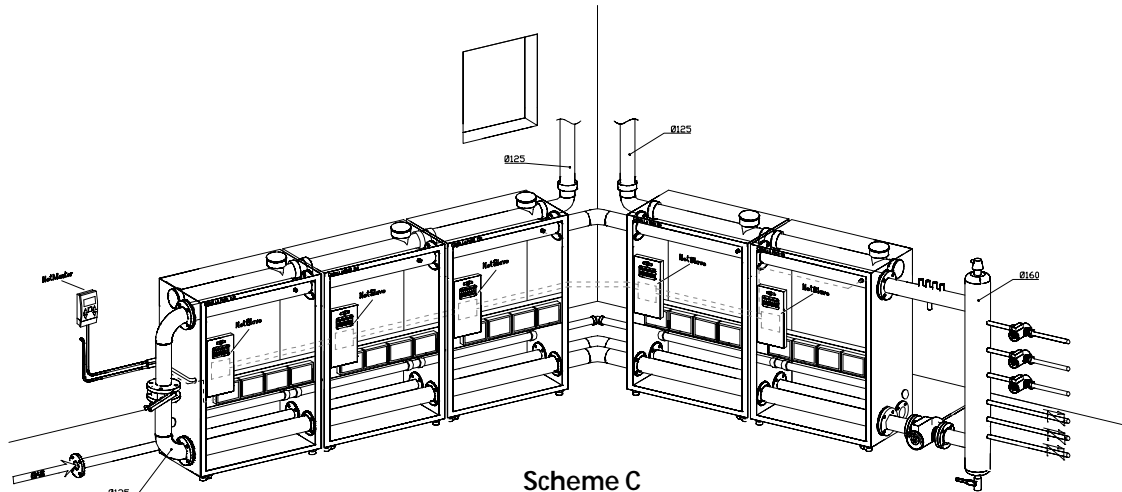

Scheme C
Battery of five Pack connected at a corner in heating thermal plant with double flue exhaust pipe Ø125 and vertical manifold with balancing.

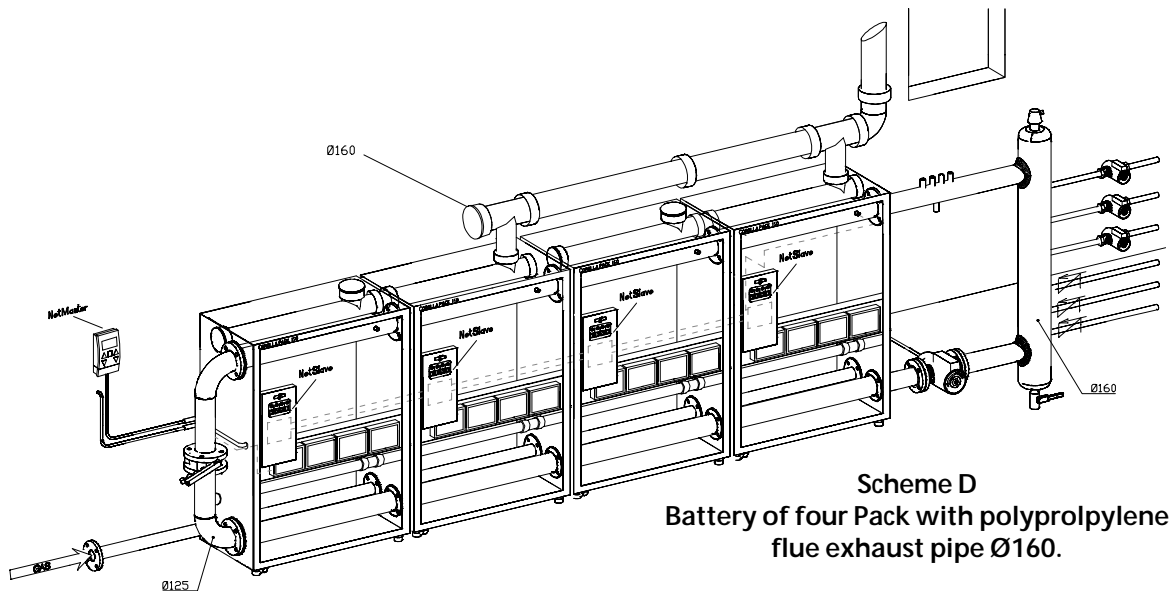

Scheme D
Battery of four Pack with polypropylene flue exhaust pipe Ø160.

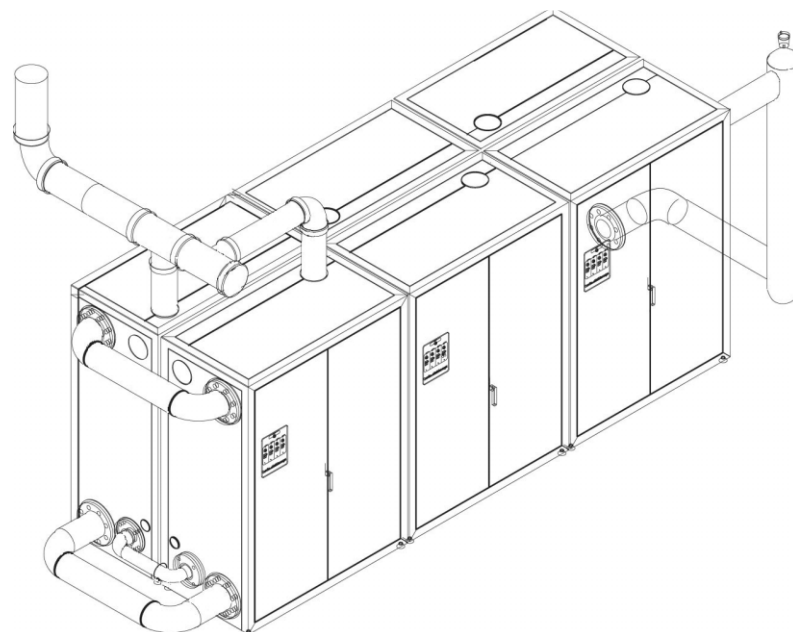

Scheme E
Battery of six Pack installed "back to back" with external exhaust flue pipe Ø160 mm, hydraulic circuit with inverse return.

Pack down a vault:

Example of installation of three Pack down a vault of a house with a vertical balancing manifold and polypropilene flue exhaust pipe i Ø125 .

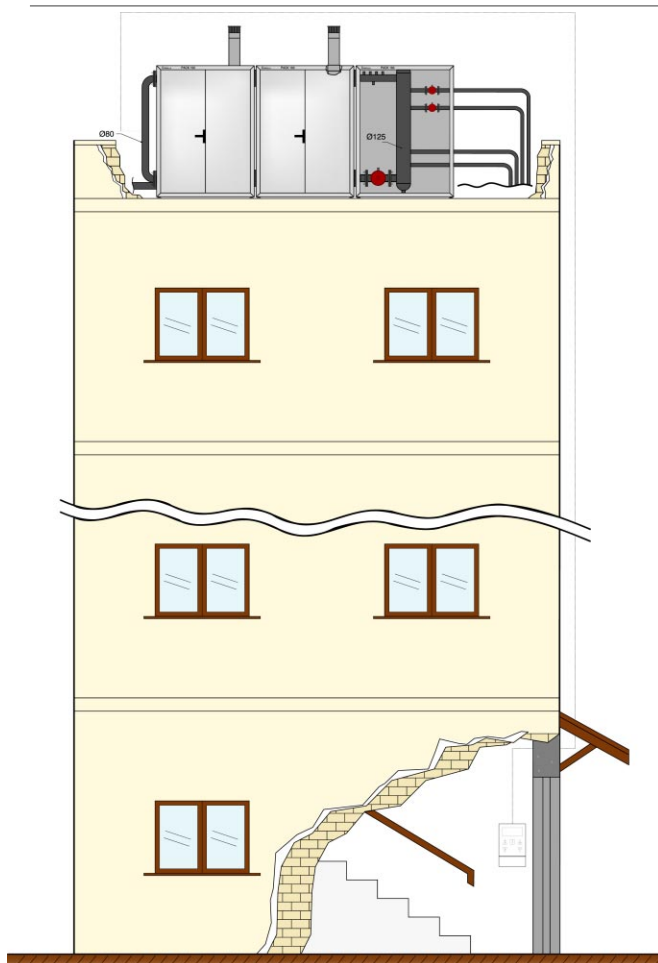
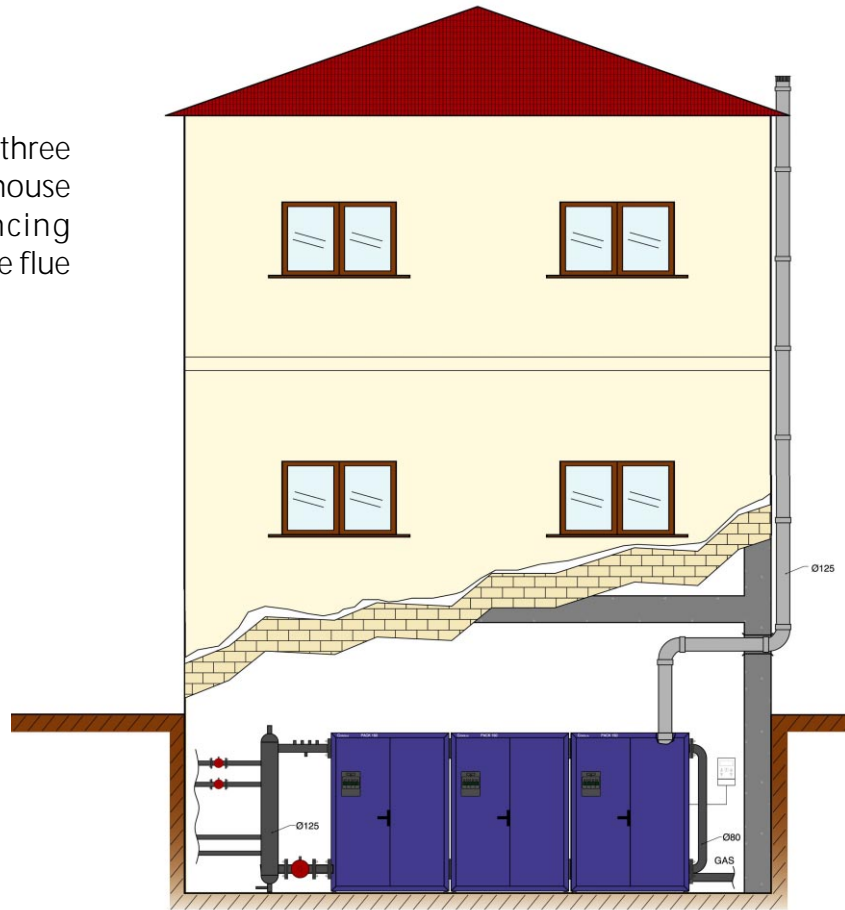

Pack inox on a roof:

Example of installation of two Pack, stainless steel version, with Pack Service hydraulic distribution group and NetMaster board at the building entrance.

Fig. 16: Examples of installation

INSTALLATION AND USER MANUAL

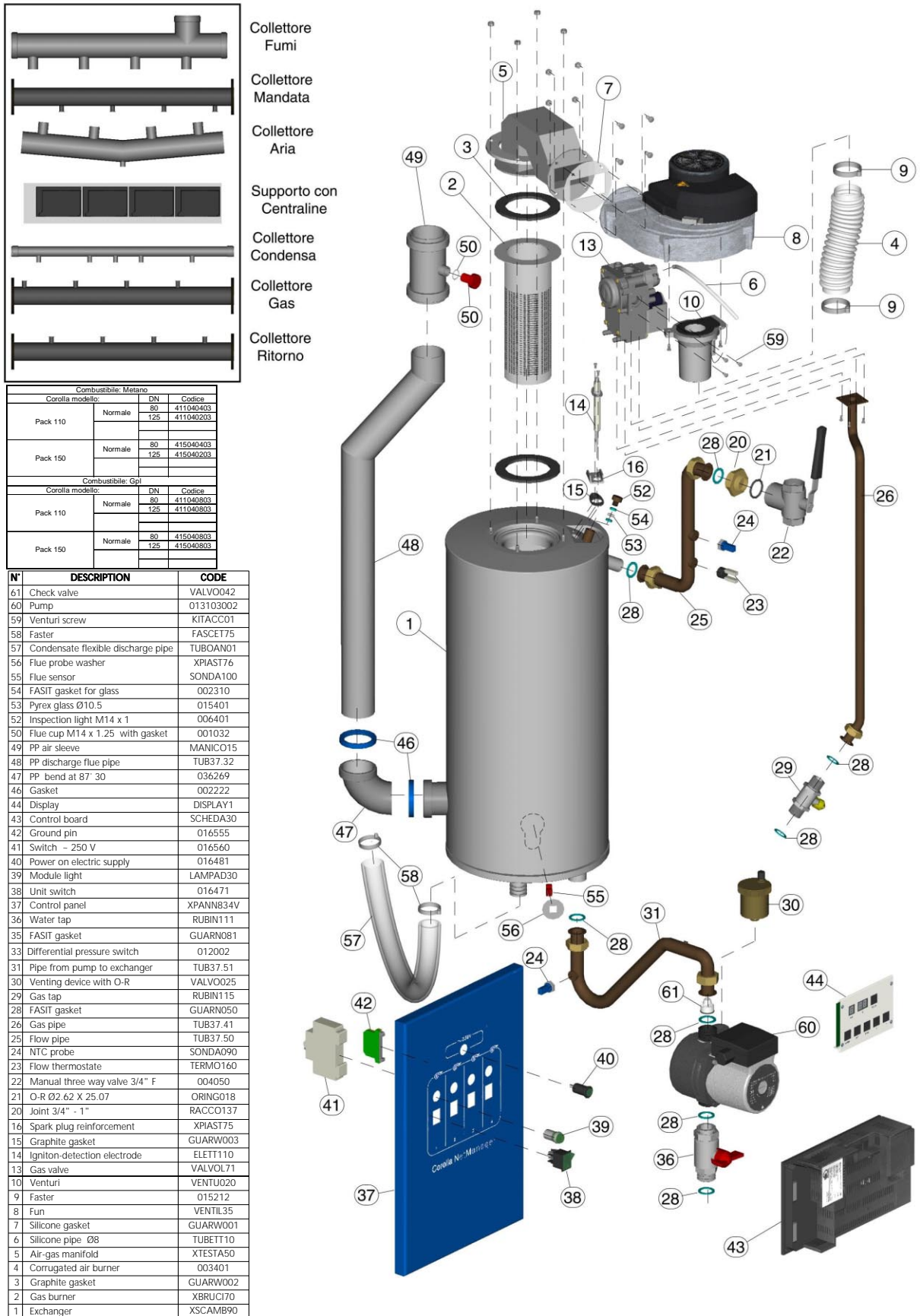

Fig. 17: Corolla Pack exploded view

23	1	Water return temperature valve
22	1	Safety thermostat
21	1	Water flow temperature probe
20	1	Air inlet manifold
19	4	Gas tap
18	1	Condensate discharge manifold d50
17	1	3" gas manifold
16	4	Gas inlet piping
15	5	Condensate exhaust pipe
14	4	Fan
13	4	Water differential pressure switch
12	4	Air/Gas manifold with non return valve
11	4	Changeover valve Room/System
10	1	PP d125 flue manifold
9	1	230V-24V transformer
8	4	Main control board
7	1	Flow water manifold (3" - 5")
6	4	Condensing exchanger
5	4	d50 flue exhaust pipe
4	4	Gas valve
3	4	Thermal element pump
2	4	Return detection tap
1	1	Flow water manifold (3" - 5")

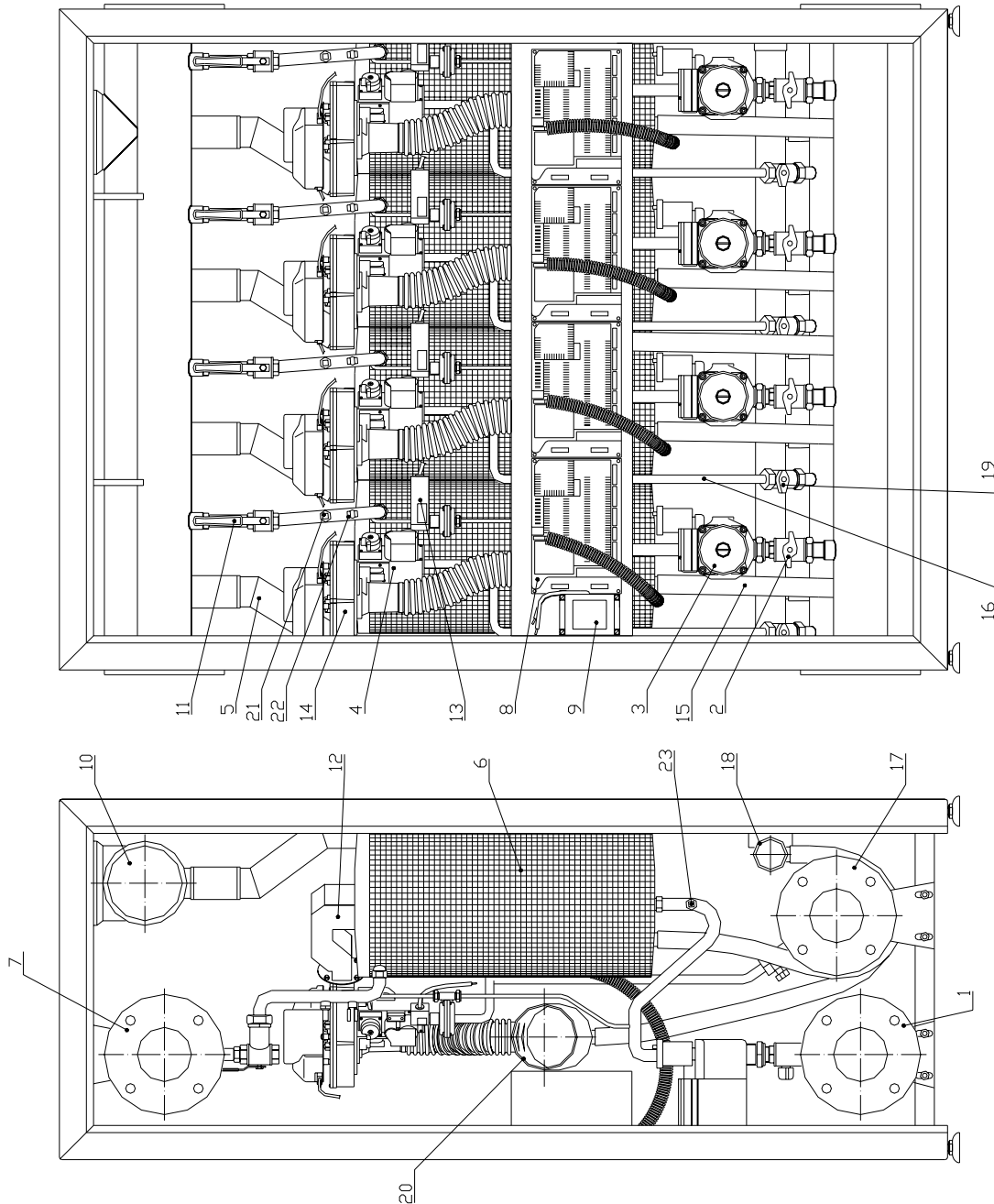

Fig. 18: Main components technical drawing

Electrical schemes - COROLLA PACK

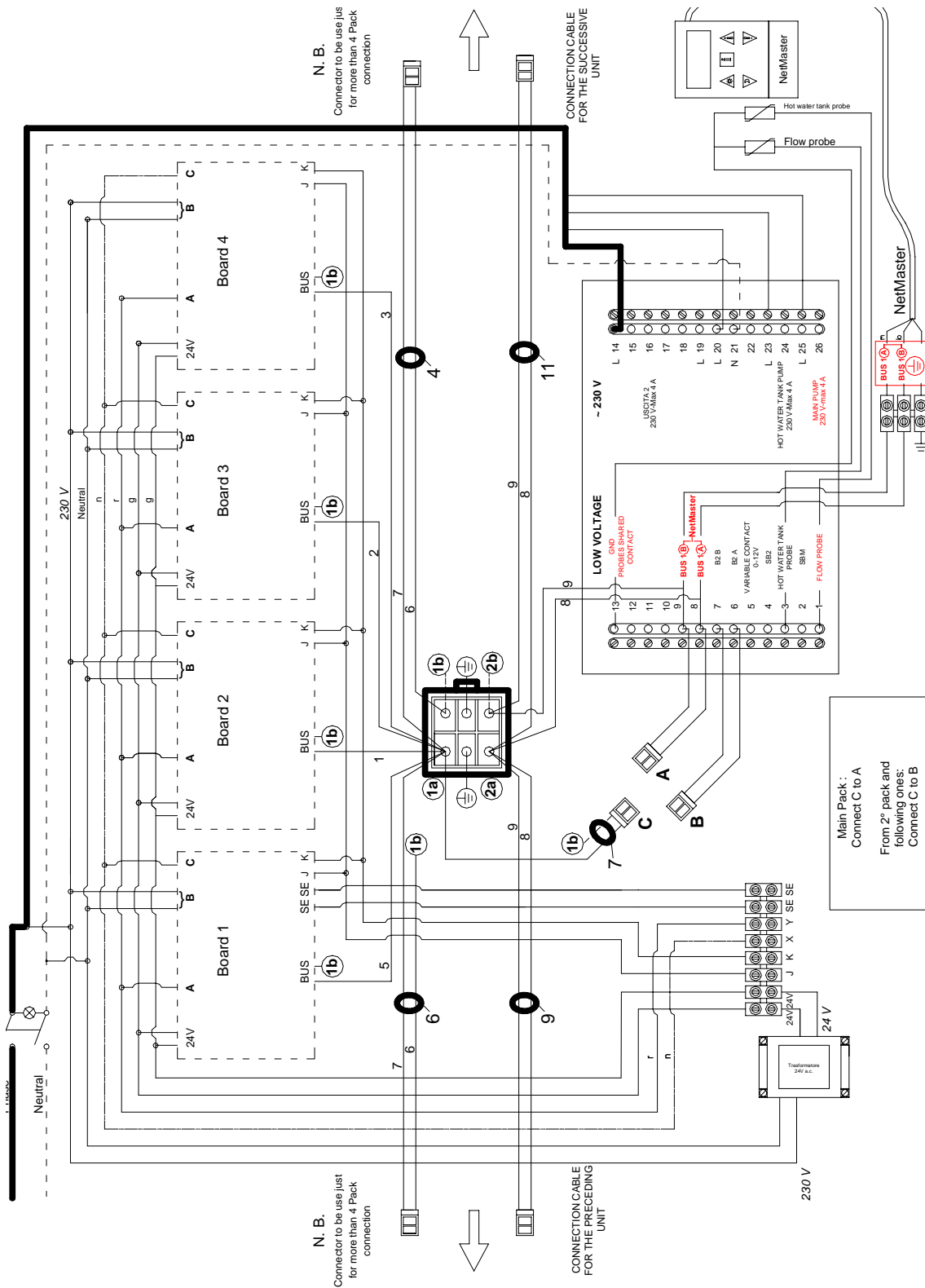

Fig. e1: Electrical scheme (general)

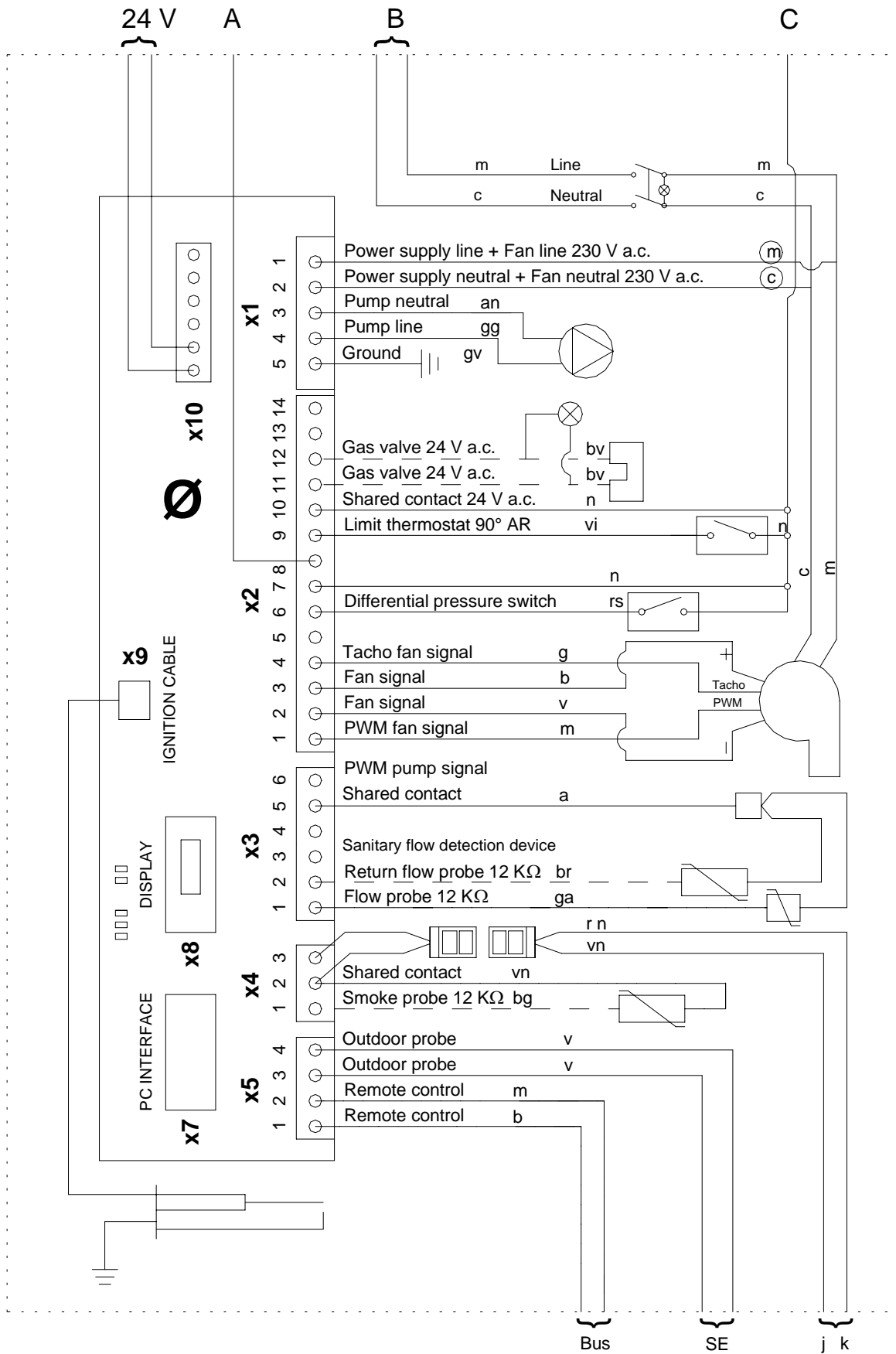

Fig. e2: Electrical scheme (single board)

INSTALLATION AND USER MANUAL

TECHNICAL DATA				
Corolla Pack	CODE: 4.XXX.40.X.03	Unit	110	150
Burners x Nominal heat input (Hs)			3 x 37,5	4 x 37,5
Gas category			II 2H3+	II 2H3+
Boiler type (EN 297)			B 23, C 63x	B 23, C 63x
CE Type	DVGW		0085AQ0441	0085AQ0441
Maximum water pressure	bar		6	6
Minimum water pressure	bar		0,5	0,5
Nominal heat input (Hi)	kW		102	135
Nominal heat input (Hs)	kW		112,5	150
Nominal heat output (80 - 60°C)	kW		99	131
Nominal heat output (50 - 30°C)	kW		110	146
Maximum condensate production (gas G20)	kg/h		16,7	22,3
Maximum electrical power	kW		0,44	0,58
Power supply	V		230	230
Water content (3" header)	l		25	30
Efficiency (Directive EN92/42/EEC) (*)				
Efficiency at full load (80 - 60°C)	%		97,1	97
Efficiency at full load (60 - 40°C)	%		106,6	106,6
Efficiency at full load (50 - 30°C)	%		108,2	108,3
Efficiency at reduced load 30% (80 - 60°C)	%		99,4	99,4
Efficiency at reduced load 30% (60 - 40°C)	%		106,2	106,2
Efficiency at reduced load 30% (50 - 30°C)	%		108,6	108,6
Combustion efficiency (80 - 60°C ; Ta = 20°C)	%		98,3	98,3
Energy lost with burner ON (80 - 60°C) Pf	%		1,7	1,7
Energy lost with burner OFF Pfb	%		0,1	0,1
Energy lost through the casing (T average = 70°C)	%		1,2	1,3
Emissions (*)				
CO - Pmin-Pmax (O2 = 0%)	ppm		14 ÷ 80	14 ÷ 80
CO2 - P.min. ÷ P. max. (0%O2)	%		8 ÷ 9	8 ÷ 9
Nox - Pmin - Pmax (O2 = 0%)	ppm		7 ÷ 20	7 ÷ 20
Manifolds diameters				
Water manifold	"		3" - 5"	3" - 5"
Inlet gas manifold	"		3"	3"
Flue manifold	mm		125	125
Air manifold	mm		50	50
Condensate manifold	mm		110	110
Dimensions and weights				
Height	mm		1500	1500
Width	mm		110	110
Depth	mm		600	600
Empty weight	kg		220	250

(*) gas G20



FONTECAL S.p.a.
Via P. Pignatelli, 13 - 65010 Villanova
(PE) - Italy
Web site: www.fontecal.it
E-mail: info@fontecal.it

This manual is valid for the following items codes:
4 XXX 40 X 03