



HAMWORTHY

heating products

**WARMWELL ATMOSPHERIC CONDENSING
BOILER 60,95 AND 140 MODELS**

**FULLY AUTOMATIC CONTROLS
PERMANENT PILOT CONTROLS**

**INSTALLATION, COMMISSIONING
AND MAINTENANCE MANUAL**

**NOTE! THESE INSTRUCTIONS MUST BE READ AND
UNDERSTOOD BEFORE INSTALLING OR
COMMISSIONING THIS BOILER.**

**WARMWELL HE ATMOSPHERIC HOT WATER CONDENSING BOILER
FOR HEATING AND DOMESTIC HOT WATER INSTALLATIONS
60, 95 AND 140 MODELS**

INSTALLATION, COMMISSIONING AND SERVICING INSTRUCTIONS

**FULLY AUTOMATIC CONTROLS
FULLY AUTOMATIC CONTROLS (HI/LO)
PERMANENT PILOT CONTROLS**

NOTE: THESE INSTRUCTIONS SHOULD BE READ AND UNDERSTOOD BEFORE ATTEMPTING TO INSTALL, COMMISSION OR OPERATE THIS UNIT

THE WARMWELL BOILER IS INTENDED FOR USE AS A COMMERCIAL APPLIANCE AND IS NOT CERTIFIED FOR USE IN DOMESTIC APPLICATIONS.

THIS BOILER IS FOR USE ON NATURAL GAS (2ND FAMILY) ONLY. PLEASE ENSURE RELEVANT INFORMATION REQUIRED WITHIN DOCUMENT IS FOUND RELATING TO SPECIFIC GAS TO BE FIRED BEFORE FIRING BOILER.

**THIS BOILER HAS BEEN TESTED TO COMPLY WITH THE GAS APPLIANCES DIRECTIVE (90/396/EEC).
EC TYPE CERTIFICATE No. BG/EC-87/95/47
EC IDENTIFICATION No. 87AQ47**

**PUBLICATION NO. 500001053
ISSUE 'C'
November 1996**

CONTENTS

	PAGE
1.0 INTRODUCTION	4
2.0 TECHNICAL DATA	4
2.1 Overall dimensions	
2.2 Technical data table	
3.0 GENERAL REQUIREMENTS	8
3.1 Related documents	
4.0 LOCATION	9
5.0 GAS SUPPLY	9
5.1 Service pipes	
5.2 Meters	
5.3 Gas supply pipes	
5.4 Boosted supplies	
5.5 Boilerhouse control valve	
5.6 Boiler gas system leak check	
6.0 FLUE SYSTEM	10
6.1 Suction	
6.2 Design waste gas volume and temperature	
6.3 Flue condensation	
6.4 Materials	
6.5 Disconnection	
6.6 Flue discharge	
6.7 Surface temperature	
6.8 Flue pipe location	
7.0 AIR SUPPLY	11
7.1 Air supply by natural ventilation	
7.2 Air supply by mechanical ventilation	
8.0 WATER CIRCULATION SYSTEM	12
8.1 General	
8.2 Pressure relief valve	
8.3 Open vent pipe and cold feed pipe	
8.4 Altitude gauge (Water pressure gauge)	
8.5 Thermometer	
8.6 Drain taps	
8.7 Circulating pump	
8.8 Minimum water flow	
8.9 Waterside pressure drop	
8.10 Control schemes	
8.11 Pressurised unvented systems	

	PAGE
9.0 ELECTRICAL SUPPLY	13
9.1 Mains cable connection	
9.2 Boiler wiring diagram	
10.0 INSTALLATION OF BOILERS	14
10.1 General	
10.2 Connection of boilers to the flue system	
10.3 Gas connections	
10.4 Water connections	
10.5 Casing and controls assembly	
11.0 COMMISSIONING AND TESTING	23
11.1 Electrical installation	
11.2 Gas installation	
11.3 Water circulation system	
11.4 Lighting the boiler (Initial Commissioning) and system leakage check	
11.5 Gas pressure adjustment and combustion checks	
11.6 Temperature limiter (Limit thermostat)	
11.7 Users instructions	
12.0 FAULT FINDING	31
12.1 Summary of safety features	
12.2 Fault finding procedures	
12.3 Possible causes of boiler lockout	
13.0 SERVICING	32
14.0 REPLACEMENT OF FAILED COMPONENTS	33
15.0 RECOMMENDED SPARES	35

FIGURES	PAGE
Fig No 1 Typical schematic boiler installation layout	5
Fig No 2 Boiler dimensions/recommended clearances	6
Fig No 3 Performance and General Data	7
Fig No 4 Water flowrate/pressure losses	9
Fig No 5 Gas valve/pipework leak check test	10
Fig No 6 Mechanical ventilation flowrates	11
Fig No 7 Balancing of Mixed Boiler Systems	15
Fig No 8 Secondary/Primary heat exchanger assembly	16
Fig No 9 Enclosure assembly details	17
Fig No 9b & 9c Exploded view of casing assembly	18/19
Fig No 10 General layout (Front view)	20
Fig No 11 Site wiring details	21
Fig No 12 Pressure sensing tube/Fan plug assembly	22
Fig No 13 Diagrams of Honeywell & SIT Automatic gas valves	24
Fig No 14 Diagram of 'Hi Flow' gas valve assembly	25
Fig No 15 Pilotstat gas valve assembly	26
Fig No 16 Diagrams of Permanent & Automatic ignition assemblies	28
Fig No 17 Diagrams of Honeywell & SIT Permanent ignition gas valves	30
Fig No 18 Gas Flows in Warmwell HE installations	36
Fig No 19 Permanent Pilot wiring schematic (Pilot-stat operation)	37
Fig No 20 Permanent Pilot wiring schematic (ECO operation)	38
Fig No 21 Automatic wiring schematic	39
Fig No 22 Automatic wiring schematic (inc. Hi/Lo operation)	40
Fig No 23 Permanent Pilot fault finding information	41/42
Fig No 24 Automatic fault finding information	43/44

1.0 INTRODUCTION

1.1 This boiler must be installed by a competent person holding 'CORGI' registration or equivalent. All installations **MUST** conform to the relevant Gas Safety and Building Regulations. Health & Safety requirements must also be taken into account when installing any equipment. Failure to comply with the above may lead to prosecution.

1.2 This boiler is intended for use on Natural Gases (2nd Family) only. For LPG (3rd Family gases) a different model is required. Please consult the boiler data plate to ascertain which gas group the boiler has been manufactured to use. A boiler **MUST NOT** use gas other than for which it was designed and made for.

1.3 The Warmwell HE is an atmospheric, gas fired boiler manufactured from horizontal cast iron sections, nipped at alternate ends. These sections are mounted on a fabricated mild steel basket assembly, which houses the burner bar and igniter assemblies. A unique radiant baffle is fitted beneath the burner bars, protecting the floor below and reducing heat lost by the boiler.

The condensing section is attached to the rear of the boiler assembly. It is arranged such that the flue gases and condensate run in a co-current flow path. This design ensures the heat exchanger is continually flushed of any salts which may form therefore ensuring no re-entrainment of flue gases which could increase acidic levels leading to aggressive condensate. The heat exchanger utilises proven materials both in the water ways (copper) and flueways (aluminium). No special water additives are required in the waterways, normal water treatment should be adequate.

An exhaustor unit pulls the flue gases through both heat exchangers and supplies adequate pressure for the connection to a header. The 45° flue piece can be rotated through 180° thus permitting vertical or horizontal connection on to the header.

1.4 If the boiler is to be connected to an unvented (pressurised) heating system, care must be taken to ensure all extra safety requirements are met and that the relevant interlocks will shut the boiler(s) off should a high or low pressure fault occur.

The Pressurisation unit must also incorporate a low level water switch which protects the water pumps and will directly or indirectly shut down the boiler plant should a low water condition occur.

Consideration should also be given to the maximum working pressure of the boiler as given in section 2: **TECHNICAL DATA**. Consult Hamworthy Heating Technical Department for help or assistance if in doubt.

1.5 The Warmwell HE boiler is not suitable for direct connection to domestic hot water supplies or gravity fed heating systems.

1.6 The Warmwell HE boiler can be installed with

either reverse return water flow layout or with single pipe header layout. See Fig.1/Page 5 for typical schematic layout.

1.7 It is good practice in all heating installations to use some form of water treatment to reduce formation of lime scale and black iron oxide sludge. The very high efficiencies produced by the Warmwell HE Boiler can easily be reduced by lime scale formation. If a pressurised unit is used, it is prudent to include an hours run meter to give an indication of pump running time and hence raw water make up. Any leaks should be attended to as soon as possible to avoid calcium salt build up within the boilers waterways.

Both automatic and permanent pilot control systems are utilised in the Warmwell HE range. Hi/Lo is available on automatic control only. See section 11.0 **COMMISSIONING AND TESTING** for procedure.

2.0 TECHNICAL DATA

2.1 Overall dimensions are shown in Fig.2/Page 6. Both single and multi boiler arrangements are shown.

The Warmwell HE boiler can be installed as a single unit or in modular form where a 'multi' casing reduces required floor area. Each boiler has an independent door for access to the controls and other working components.

It is recommended that a maximum of 6 boilers can be positioned on 533 mm (21") centres if required. Larger numbers should be split into two or more banks with 150 mm (6") between each bank. **NOTE!** To install modular units on 533 mm (21") centres, the casing support rail or spacing plates should be fitted between each boiler before bolting together. See Section 10.1: **GENERAL INSTALLATION OF BOILERS** Ref:- spacing plates for further information. See Fig.2/Page 6 re:- coupling of Warmwell HE and Purewell boilers. The boiler can also be installed in a 'stand alone configuration' if required.

2.2 Technical and General Data information is shown in Fig.3/Page 7.

2.3 **Screw threads:** All screw threads used in the Warmwell HE boiler conform to the following:-
ISO 7/1 or ISO 228/1 for pipe threads where applicable. ISO 262 for all general screw threads.



HAMWORTHY

heating products

Figure No 1 Boiler Installation (Typical)

Key: t - Thermometer
p - Pressure gauge

VENTED SYSTEM

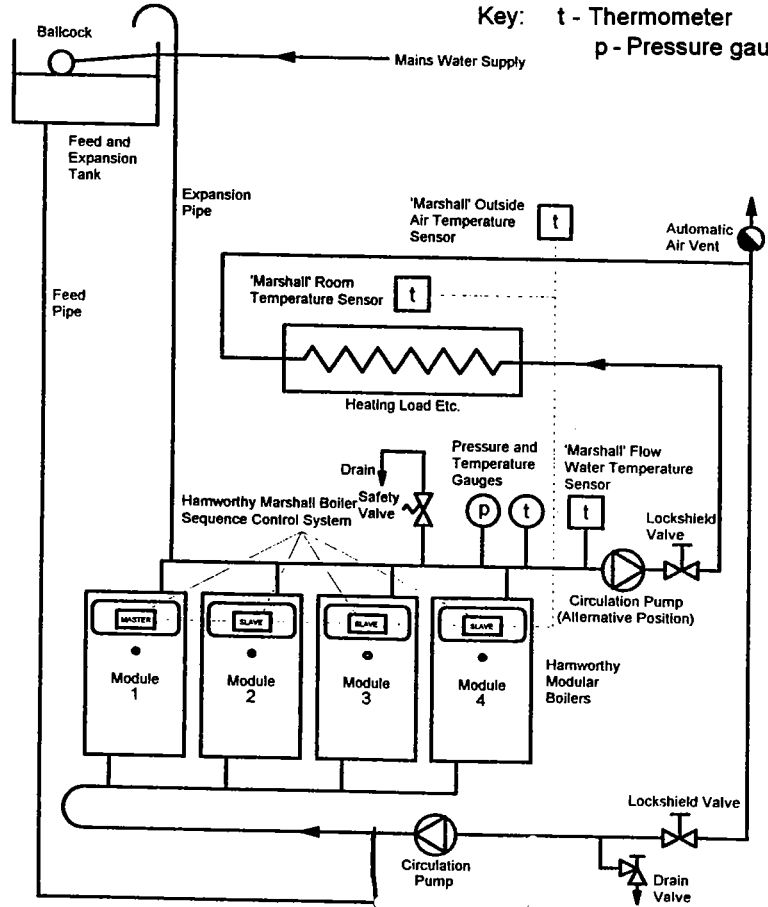

UNVENTED SYSTEM

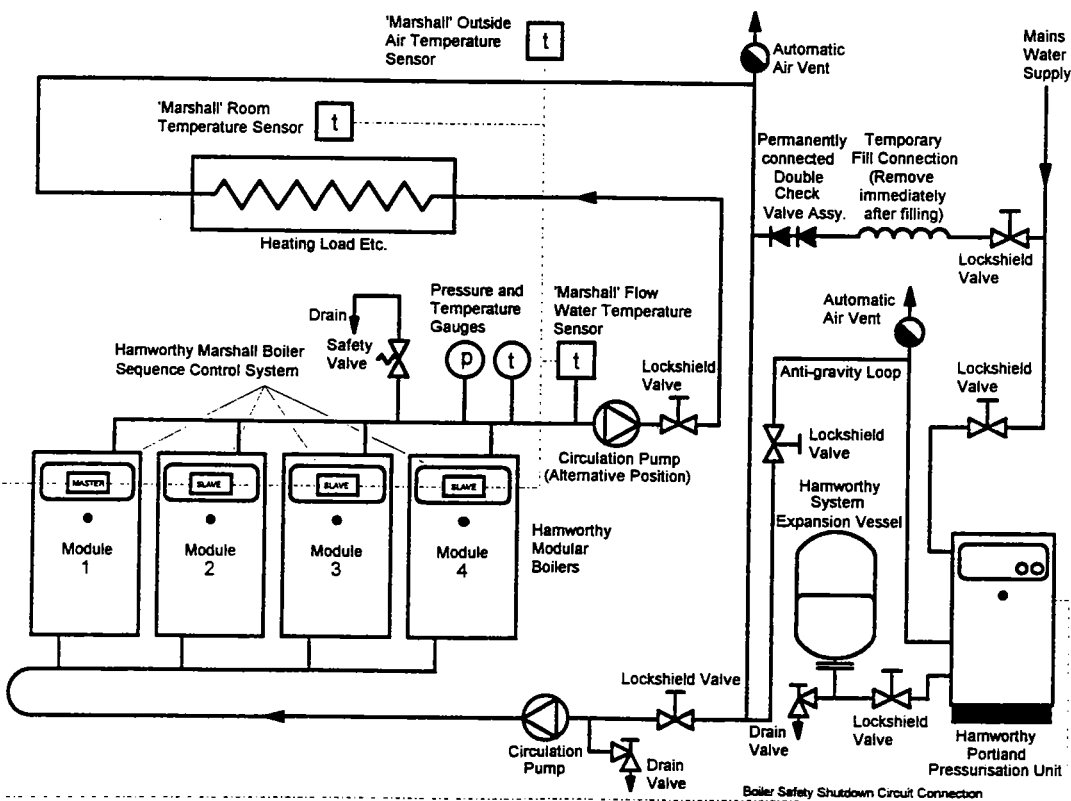



HAMWORTHY

heating products

Figure No 2 Boiler Dimensions/Clearances

	Boiler Model		
	HE 60	HE 95	HE 140
Approx. Dry Weight kg	285	335	450
A - Boiler Height (Casing) mm	872	872	1060
B - Gas Connection Height mm	769	769	957
C - Return Connection Height mm	953	1047	1235
D - Gas Connection - (BSP.T Male)	R ¾"	R ¾"	R 1"
E - Flow Connection Height mm	573	667	855
F - Flue Outlet I/Dia. mm (Nominal)	150	150	150

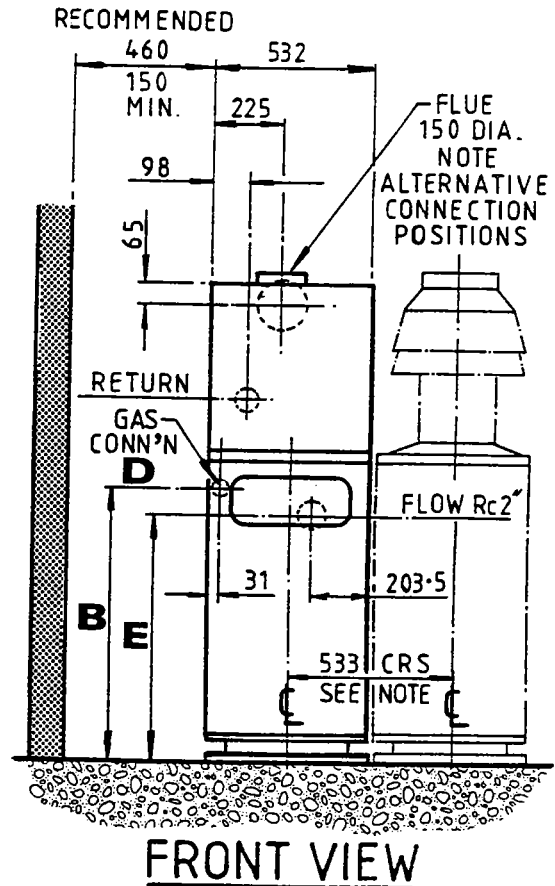
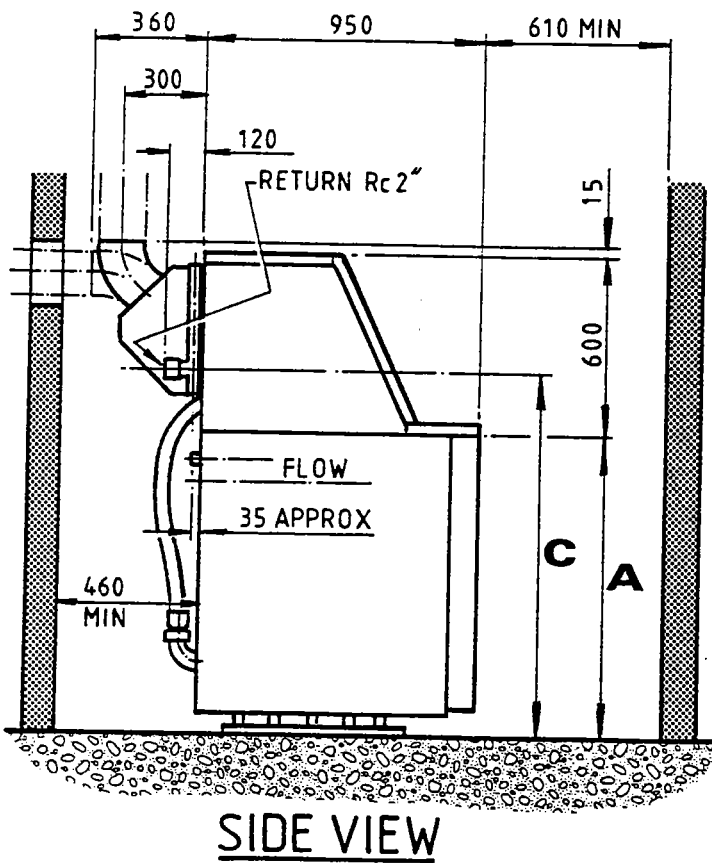

Note! For modular applications, the top casing from the 60 and 95 models can only be fitted to Purewell 40 - 80 kW range. And likewise the 140 model top casing can only be fitted to Purewell 95 - 120 kW range. If a different mix is required the Warmwell HE will have to be installed in stand alone form.

The 533 centres relate to boilers close coupled in modular form. For stand alone applications a minimum of 150 mm should be allowed between casings. (Space baskets 200 mm apart)

Figure No 3 Performance and General Data Information

GENERAL DATA	HE 60	HE 95	HE 140
Boiler input kW (Gross)	63.4	101	150
Boiler input kW (Nett)	57.1	90.9	135
Boiler output (Condensing) kW	59	93	135
Boiler output (Non-condensing) kW	54	86	128
Gas flow rate m ³ /h.	5.92	9.44	14.1
Gas manifold pressure mbar.	12.5	9.5	11.0
Start (low fire) manifold pressure mbar. (Automatic only)	5.0	1.5	1.2
Pressure switch setting. (Normal) / (High) " (Low)	1.8 mbar 1.5 mbar	1.8 mbar 1.5 mbar	3.0 mbar 0.6 mbar
FLUE DATA			
Nominal flue I/Dia. mm.	————— 150 —————		
Approx. flue gas temperature (Condensing) °C	45	45	45
Approx. flue gas temperature (Non-condensing) °C	65	65	65
Approx. flue gas vol. Condensing @ 9% CO ₂ & NTP.(Dry) m ³ /hr	82.81	132.05	197.2
GAS DATA			
Nominal gas inlet press. mbar.	————— 20 —————		
Maximum gas inlet press. mbar.	————— 25 —————		
Injector marking/Dia. mm.	3.1	4.2	4.4
No. of Burner bars/Injectors	————— 4 —————		— 5 —
Gas inlet connection pipe thread size.	————— R ¾" —————		— R 1" —
WATER DATA			
Water Connections	Flow Rc 2"		Return Rc 2"
Loss mbar @ 20°C ΔT rise	17.65	50.0	117.7
Maximum water pressure	————— 6 barg. —————		
Water content litres	36	43	57
Water flow rate @ 15 °C ΔT rise litres/s	0.94	1.46	2.15
" 20 °C ΔT rise litres/s	0.70	1.10	1.61
ELECTRICAL DATA			
Normal Supply Voltage	————— 230 V AC 50 Hz 1 ph —————		
Current Requirements (Std. Boiler)	————— < 2 Ampere —————		

3.0 GENERAL REQUIREMENTS

3.1 RELATED DOCUMENTS.

Gas Safety Installations and Use Regulations 1994. It is law that all gas appliances are installed by competent persons in accordance with the above regulations. Failure to install appliances correctly could lead to prosecution. It is in your own interest, and that of safety, to ensure that this law is complied with.

The installation of the boiler **MUST** be in accordance with the relevant requirements of the Gas Safety Regulations, Building Regulations, I.E.E. Regulations and the byelaws of the local water undertaking.

The installation should also be in accordance with any relevant requirements of the local gas region and local authority and the relevant recommendations of the following documents:-

British Standards

BS 7074: Application, selection and installation of expansion vessels and ancillary equipment for sealed water systems. **Part 2:** Code of practice for low and medium temperature hot water systems.

BS 6891: Installation of low pressure gas pipework of up to 28 mm. in domestic premises. (For larger installations see **IM/2**, **IM/5** and **IM/16**)

BS 6644: Installation of Gas Fired Hot Water Boilers - 60 kW to 2MW.

BS 6700: Design, installation, testing and maintenance of services supplying water for domestic use.

BS 6880: Part 1, 2 & 3: Code of practice for low temperature hot water heating systems of output greater than 45 kW.

BS EN 60335, Part 1. Safety of Household & similar electrical appliances. BS 3456, Part 201: Electrical Standards.

CP 342: Centralised hot water supply.
Part 2: Buildings other than individual dwellings.

British Gas Publications

IM/2 Purging procedures for non-domestic gas installations.

IM/5 Soundness testing procedures for industrial and commercial gas installations.

IM/11 Flues for commercial and industrial gas fired boilers and air heaters.

IM/16 Guidance notes on the installation of gas pipework. (Excluding domestic installations of 25 mm and below.)

Health and Safety Executive:-

Guidance note PM5 - Automatically controlled steam and hot water boilers.

C.I.B.S. Publications:- "C.I.B.S. (I.H.V.E.) Guide"
It is impractical in this document to specify all

relevant information, but the following extracts from the above references are emphasized since failure to comply with these requirements will almost certainly result in an unsatisfactory installation.

3.2 FEED WATER QUALITY

If the boiler feed water has a high degree of hardness, it is recommended that the water be treated to prevent precipitation of scale or sludge in the boiler water passageways. Details of additives can be obtained from any reliable manufacturer of water treatment products or the local water authority.

It should be noted however, that even if the boiler water is of average hardness, not requiring treatment, subsequent draining of the system for repair or constant make-up water due to an undetected leak will cause additional deposits and gradual build-up of scale. It is essential therefore, that leaks are attended to promptly and draining is kept to an absolute minimum.

It is recommended that the system be flushed out at least twice before any water treatment is added. If any doubt exists regarding the internal cleanliness of an old system, consideration should be given to the fitting of a coarse filter in the return pipework to the boilers.

3.3 ADEQUATE WATER FLOW

The Hamworthy Warmwell HE boiler is designed as a quick response, low water content unit, to run continuously with maximum reliability. Care should be taken in the initial design and layout having due regard for adequate water flow through the boilers and the influence of the system controls.

The Warmwell HE boiler is tested with flow/return temperatures of 50°/30°C to ensure condensing takes place thus achieving the correct output. The boiler can also be used in the high efficiency mode with flow/return temperatures of 80°/60°C ie non-condensing where it will provide the lower heat output as given in Fig 3/Page 7.

If the temperature/flowrates of the application cannot meet those given in Fig 4/Page 9, it may be necessary to incorporate mixing valves and shunt pumps to ensure that the boiler will operate satisfactorily. See Fig.7/Page 15.

The pressure loss though the Warmwell HE boiler is generally higher than the equivalent Purewell unit. It therefore may be necessary to incorporate balancing valves where these units are mixed on the same header. See Fig.7/Page 15.

Fig.4/Page 9 shows recommended and minimum water flows required. The control system and valves, where fitted, should be regulated to avoid lower flows occurring. The flow corresponding to 22 °C temperature rise across the boiler is the minimum

Figure No 4 Flowrate/Pressure drop table

Model	60	95	140
Flow rate l/s @ 15 °C ΔT rise	0.94	1.46	2.15
Pressure loss mbar	35.3	86.3	206
Flow rate l/s @ 20 °C ΔT rise	0.70	1.10	1.61
Pressure loss mbar	17.6	50	117.7

recommended at any time. For boiler pressure drop see Fig.4/Page 9.

3.4 TIME CLOCK CONTROL

In order to avoid local overheating and progressive calcium deposition at zero flow conditions where boilers are operated from time clocks, provision should be made for a 5 minute circulating pump over-run after the last boiler has ceased firing.

NOTE! Time clocks should not interrupt live, neutral or earth connections, see Section 9.0: **ELECTRICAL SUPPLY** for details. See Fig.11/Page 21 for wiring details.

3.5 MINIMUM SYSTEM WATER PRESSURE

To comply with guidance note **PM5 (Health and Safety Executive)**, the minimum pressure requirements at the boiler are given below as examples:-

1) Single installed boiler running at 82°C flow temperature. Minimum head required is not less than 2 metres or 0.2 bar.

2) Single installed boiler running at 95°C flow temperature. Minimum head required = 5.1 metres or 0.5 bar. **See Section 8.10.1**

3) Modular boiler installation running at 82°C flow temperature and 11°C rise across system. Minimum head required = 4.3 metres or 0.42 bar.

4) Modular boiler installation running at 82°C flow temperature and 22°C rise across system. Minimum head required = 10.5 metres or 1.03 bar. **See Section 8.11** for Pressurised Water Systems.

4.0 LOCATION

4.1 (See Fig.2/Page 6 for dimensions/weights and clearances.) The location chosen for the boiler **MUST** permit the provision of a satisfactory flue system and an adequate air supply. The location must also provide adequate space for servicing and air circulation around each unit. This includes any electrical trunking laid along the floor.

Allow adequate space, this must not be less than 460 mm. at the rear, for flow and return connections. Also allow at least 460 mm. on one side, the other side must be no less than 150 mm. Allow 610

mm.(minimum) in front of the boiler for servicing.

The boiler must be installed on a level non-combustible surface that is capable of adequately supporting its weight (when filled with water) and any ancillary equipment.

Any combustible material adjacent to the boiler and the flue system must be so placed or shielded to ensure that its temperature does not exceed 65°C (150°F).

Further details regarding boiler location are given in **BS 6644**.

5.0 GAS SUPPLY

5.1 SERVICE PIPES

The local gas region must be consulted at the installation planning stage in order to establish the availability of an adequate supply of gas. An existing service pipe must not be used without prior consultation with the local gas region.

5.2 METERS

A new gas meter will be connected to the service pipe by the local gas region, or a local gas region contractor. An existing meter should be checked, preferably by the gas region, to ensure that it is adequate to deal with the rate of gas supply required.

5.3 GAS SUPPLY PIPES

Supply pipes must be fitted in accordance with **BS 6891** or **IM/16** as appropriate. Pipework from the meter to the boiler must be of adequate size. Do not use pipes of a smaller size than the boiler gas connection. The complete installation must be purged and tested for soundness as described in **BS 6891** or **IM/2** and **IM/5** as appropriate.

See Fig.18/Page 36 for recommended gas flows in pipes.

5.4 BOOSTED SUPPLIES

Where it is necessary to employ a gas pressure booster, the controls must include a low pressure cut-off switch at the booster inlet. The local gas region must be consulted before a gas pressure booster is fitted.

5.5 BOILER HOUSE CONTROL VALVE

A manual valve for boiler house isolation shall be fitted in the gas supply line. It shall be clearly identified and readily accessible for operation, preferably by an exit.

5.6 BOILER GAS SYSTEM LEAK CHECK

Although the boiler receives a gas leak check and gas train component integrity check prior to leaving the factory, transport and installation may cause disturbance to unions, fittings and gas valve assemblies etc. During commissioning a further test for soundness should be carried out on the boiler gas pipework and components. A procedure guide is given below. Care must be taken not to allow leak detection fluid (if used) on or near any electrical parts or connections.

6.0 FLUE SYSTEM

Detailed recommendations for flue systems are given in **BS 6644**, British Gas Publication **IM/11**, "Flues for Commercial and Industrial Gas-Fired Boilers and Air Heaters."

The following notes are intended to give general guidance only.

6.1 FLUE SYSTEM GENERAL REQUIREMENTS

The Hamworthy Warmwell HE series of boilers are designed to be used with natural draught flues. Flue systems should be designed in accordance with current regulations and with reference to the British Gas publication **IM/11** "Flues for Commercial and Industrial Gas Fired Boilers and Air Heaters". The following points should be noted:-

1) Flue gas temperatures from traditional boilers will be typically 150-200°C which gives buoyancy thus tending to balance resistances through the boiler and primary/secondary flueways. Condensing boilers (in condensing mode) have flue gases at/or approaching water return temperatures. These gases will be in a saturated condition therefore continuous condensation in the flueways must be expected.

2) The flue system must be self supporting in the correct position to enable its removal for boiler cleaning. (Condensing heat exchanger only).

3) Boilers should be located as near the chimney as possible the nearest being not more than 2 m. (6 ft) away.

4) The flue system should be designed to achieve a negative suction at all times on all modules in a bank. For optimum performance, draught conditions should be between -0.05 to -0.125 mbar. In some instances, mechanical assistance may be necessary. The boilers are suitable for connection to a fan diluted flue system, refer to British Gas publication **IM/11** "Flues for Commercial and Industrial Gas Fired Boilers and Air Heaters".

6.2 DESIGN WASTE GAS VOLUME AND TEMPERATURE

The flue gas temperature will be dependant on the system return temperature - Fig 3/Page 7 gives maximum and minimum temperatures based on non-condensing and condensing modes. It should be assumed that there will be no buoyancy aid from the hot gas leaving the boiler. It is therefore recommended that the flue resistance should not exceed 0.1" wg.

It is recommended that the volume and temperature of the waste gases used for design of the flue system are as shown in Fig.3/Page 7.

TO CHECK B

- 1) Turn off the electrical power and gas to the appliance.
- 2) Connect the manometer assembly to test point (Fitted on gas valve.)
- 3) With A, B closed open C and monitor manometer

Figure No 5 Warmwell HE Boiler Gas valve/pipework leak test procedure.

over a 2 minute period, a rise indicates a leak on valve B.

TO CHECK A

- 1) Open C.
- 2) Crack B to produce approx. 17 mbar(6.8") static between A and B.
- 3) Close B
- 4) System may be considered sound if over a period of 2 minutes any drop in pressure is less than 0.5 mbar (0.2" wg.).

NOTE: Allow a manometer stabilisation period of approximately 1 minute before each 2 minute check period.

Following soundness tests close valve B and remove manometer connections and tighten test points.

6.3 FLUE CONDENSATION

Care should be taken to ensure the flue is installed in such a way that condensation produced on start up or during normal run is piped to an appropriate drain.

6.4 MATERIALS

Materials used for the flue system must be mechanically robust, resistant to internal and external corrosion, non-combustible and durable under the

conditions to which they are likely to be subjected.

Condense will be produced in normal operation of the Warmwell boiler. The materials used in the flue construction must be suitable for saturated flue gas and assembled such that condense naturally drains to traps and does not 'leak' from joints.

Consideration should be given to possible freezing of condense water traps and pipework. This must be avoided at all times. Insulate condense pipes if freezing temperatures are likely to be encountered.

6.5 DISCONNECTION

Provisions should be made for disconnection of the flue pipe for servicing. It is advisable that bends are fitted with removable covers for inspection and cleaning as appropriate. **NOTE!** The flue system must be self supporting.

See section 13: **SERVICING** for further information.

6.6 FLUE DISCHARGE

The flue system must ensure safe and efficient operation of the boiler to which it is attached, protect the combustion process from wind effects and disperse the products of combustion to the external air.

The flue must terminate in a freely exposed position and be so situated as to prevent the products of combustion entering any opening in a building.

Where the flue diameter is less than 200 mm (8") a terminal must be fitted. Where the flue is of a larger size consideration should be given to the fitting of a flue discharge terminal or grill to stop ingress of birds etc.

6.7 SURFACE TEMPERATURES

Combustible materials in the vicinity of the boiler and flue shall not exceed 65°C during boiler operation. The flue shall not be closer than 50 mm to any combustible material, except where it passes through such material with a non-combustible sleeve when the air gap may not be less than 25 mm.

6.8 FLUE SYSTEM LOCATION

The flue system must not be placed or fitted where there is undue risk of accidental damage to the flue pipe or undue danger to persons in the vicinity. **NOTE!** The flue **MUST** be self supporting. Check that the flue and chimney are clear from any obstruction.

7.0 AIR SUPPLY

Detailed recommendations for air supply are given in **BS 6644**. The following notes are intended to give general guidance. In all cases there must be provision for an adequate supply of air for both combustion and general ventilation, in addition to that required for any other appliance.

7.1 AIR SUPPLY BY NATURAL VENTILATION

The boiler room must have, or be provided with, permanent air vents directly to the outside air, at high level and at low level. For an exposed boiler house, air vents should be fitted preferably on all four sides,

but at least on two sides. Air vents should have negligible resistance and must not be sited in any position where they are likely to be easily blocked or flooded or in any position adjacent to an extraction system which is carrying flammable vapour. Grilles or louvres must be so designed that high velocity air streams do not occur within the space housing the boiler.

The air supplied for boiler house ventilation shall be such that the maximum temperatures within the boiler house shall be as follows:

- 1) At floor level (or 100 mm above floor level) = 25 °C.
- 2) At mid-level (1.5 m above floor level) = 32 °C.
- 3) At ceiling level (or 100 mm below ceiling level) = 40 °C.

Where both low and high level openings are used, the grilles shall have a total minimum free area of:-

Low Level (inlet) 540 cm² plus 4.5 cm² per Kilowatt in excess of 60 Kw total rated input.

High Level (outlet) 270 cm² plus 2.25 cm² per Kilowatt in excess of 60 Kw total rated input.

7.2 AIR SUPPLY BY MECHANICAL VENTILATION

Air supplied to the boiler room by Mechanical means should be as follows:-

1) Mechanical inlet and mechanical extract can be utilised providing design extraction rate does not exceed one third of the design inlet rate.

2) Mechanical extract ventilation with natural inlet ventilation **MUST NOT** be used.

NOTE: For Mechanical ventilation systems an automatic control should be provided to cut off the gas supply to the boiler, in the event of failure of air flow in either inlet or extract fans.

Figure No 6 Mechanical Ventilation Flow Rates

Atmospheric Boilers	Flow rate per 1000 kW total rated heat input	
	Inlet air (Combustion Ventilation)	Extract air (Ventilation)
	m ³ /s	m ³ /s
Volume	1.10	0.45

8.0 WATER CIRCULATION SYSTEM

8.1 GENERAL

The Warmwell HE Boiler has a low water content and the requirements of minimum water flow are given in Section 8.8:MINIMUM WATER FLOW RATES and Fig.4/Page 9. Recommendations for the water circulation system are given in BS 6644 and CP 342. The following notes are of particular importance:-

1) In a combined central heating and hot water system, the hot water storage vessel must be of the indirect cylinder or calorifier type. The hot water storage vessel should be insulated preferably with not less than 75 mm (3 in) thick mineral fibre, or its thermal equivalent.

2) Circulating pipework not forming part of the useful heating surface should be insulated to help prevent heat loss and possible freezing, particularly where pipes are run through roof spaces and ventilated cavities. Cisterns situated in areas which may be exposed to freezing conditions, should also be insulated. Insulation exposed to the weather should be rendered waterproof.

3) Draining taps must be located in accessible positions which permit the draining of the whole system, including the boiler and hot water storage vessel.

4) Each boiler has one 2" BSP female flow and one 2" BSP female return tapping. Boilers should be connected by flow and return headers but sufficient length of connecting pipe should be allowed to clear the casing before connecting into the headers. The headers should be connected to the system in a "reverse return" arrangement (the water flow in each header is in the same direction) to ensure equal flow in each module. Fig.1/Page 5 shows typical layout.

5) Due to the higher pressure losses of the Warmwell HE heat exchanger compared to the Purewell, it may be necessary to install a shunt pump or balancing valve to enable correct flow through these combined boiler systems.

8.2 PRESSURE RELIEF VALVE (SAFETY VALVE)

Each boiler, or in the case of a modular installations, each bank of boilers, must be fitted with a pressure relief valve to BS 759 or BS 6759 Part 1 (ISO 4126) and sized as shown in BS 6644.

BS 6644 provides comprehensive information for the selection and location of safety valves and attention is drawn to the higher capacity requirements of safety valves for pressurised hot water systems.

8.3 OPEN VENT PIPE AND COLD FEED PIPE

(See BS 6644 for further information.)

Every boiler or group of boilers should have an open vent pipe and cold feed pipe installed between the boiler and the first water isolating valve. The minimum bore (mm.) of these pipes per installation is as follows:-

The vent pipe must rise continually, must not be valved except by a design which when closed for maintenance the boiler is open to atmosphere. The

pipe shall be protected against freezing where this might occur.

8.4 ALTITUDE GAUGE (WATER PRESSURE GAUGE)

Every boiler or group of boilers should be provided with a gauge complete with isolating cock. See Fig.1/Page 5 for typical position.

Boiler Input	Feed	Vent
< 60 kW	19	25
60 kW - 150 kW	25	32
150 kW - 300 kW	32	38
300 kW - 600 kW	38	50

8.5 THERMOMETER

See Fig.1/Page 5 for typical position.

A thermometer complete with pocket should be fitted in the pipework to indicate water flow temperature.

8.6 DRAIN COCKS

Each boiler should have a ½" NB drain cock (not H.H.L. supply) fitted to drain the boiler only. The heating system in total should have drain cocks as recommended by BS 6644. See Fig.1/Page 5 for recommended positions.

8.7 CIRCULATING PUMP

One or more circulating pumps will be required to circulate water around the boilers and heating system. Fig.4/Page 9 shows the hydraulic resistance of the boiler. The pump should be sited to facilitate servicing. It is important to note that when Warmwell HE boilers are used to replace boilers on an existing system, the pumps should be checked for performance against the new boiler waterside pressure drop to ensure that the minimum flow rate can be obtained. It is also important that the existing system be flushed through twice to remove any loose matter which may have accumulated. If in any doubt regarding the cleanliness of the system, a coarse filter should be fitted in the return pipework to the boilers.

8.8 MINIMUM WATER FLOW RATES

Minimum water flow rates are shown in Fig.4/Page 9. These flow rates should be maintained through the boiler at all times whilst the boiler is firing. If the water flow rate is allowed to fall below the minimum, the boiler heat exchanger could fail due to the resultant scale formation. Particular attention should be paid to the restriction of external flow circuits during periods of low heat demand.

8.9 WATERSIDE PRESSURE DROP

The waterside hydraulic resistance (Pressure

drop) is shown in Fig.4/Page 9. **NOTE:** If boilers are run off time clock control, a pump overrun (not H.H.L. supply) should be fitted which must run for a minimum of 5 minutes on shut-down of the last boiler.

8.10 CONTROL SCHEMES

8.10.1 TEMPERATURE CONTROLS

An adjustable control thermostat is supplied for each boiler and should be set to operate within the range 30-90°C for standard applications.

If the boiler is required to run in condensing mode the return temperature should be between 30-45°C. The control thermostat should therefore be set at 45-55°C. This will be dependant on boiler water flowrate and hence ΔT achieved.

If a higher water temperature is required ie boiler in non-condensing mode, (and providing sufficient head on the water system is available) the thermostat may be adjusted to operate up to 90°C. A temperature limiter, (hand reset limit thermostat) is also fitted to the boiler and must be set at 100°C. **NOTE!** To meet the EN Standard the temperature limiters maximum setting should be 100°C. The minimum difference between control thermostat and temperature limiter must never be less than 10°C.

8.10.2 WATER FLOW CONTROLS

Any external mixing valve/shunt pump or similar controls should **ALWAYS ENSURE** that the minimum water flow rate as shown in Fig.4/Page 9 is maintained.

8.10.3 FROST PROTECTION

Consideration should be given to fitting a frost thermostat set at approximately 4°C (39°F).

8.11 UNVENTED PRESSURISED SYSTEMS

See Fig.1/Page 5 for typical layout of a Pressurised (Un-vented) Hot Water System. For system design refer to **BS 7074 Part 2**.

In order to correctly size a pressurisation unit for any heating system certain parameters are required. These are:-

- 1) Static height of highest component in system (metres).
- 2) System volume - if it is not known a general rule of thumb of 10 litres/kW of installed boiler power can be used.
- 3) Maximum flow temperature (°C).
- 4) Maximum system hot working pressure, generally given in barg.

From the above information Hamworthy Heating can size the pressure unit and also the expansion vessel required.

Care must be taken in sizing expansion vessels to ensure maximum acceptance factors are not exceeded. Normally manufacturers of vessels impose a limit of 0.5. This value must not be exceeded at any time during the operation of the boiler: this includes the over pressure condition should a safety valve lift.

Consideration should also be given to sizing of the safety valve(s) in the system. See **BS 6759: Part**

1, (**ISO 4126**) for information.

See also **BS 6880: Part 1** for design considerations.

9.0 ELECTRICAL SUPPLY

WARNING: THIS APPLIANCE MUST BE EARTHED

Wiring external to the boiler must be installed in accordance with the I.E.E Regulations and any local regulations which apply. Wiring must be completed in heat resistant 3 core cable. (Size 1.0 mm² c.s.a.). Boilers are normally supplied suitable for 230 volts, 50 Hz. Fascia fuse rating is 2 A. External fuses should be 6 A. for all single boiler sizes.

The method of connection to the mains electricity supply must facilitate complete electrical isolation of the single boiler/battery with a contact separation of at least 3 mm in all poles.

A mains isolator must be provided adjacent to the boiler in a readily accessible position. The supply should only serve the boiler. **NOTE!** Volt free contact electrical supplies must also be isolated when fitted (see note on fascia). Further details regarding connection to the electricity supply are given in **BS EN 60335, Part 1** or **BS 3456, Part 201**.

The power supply should not be switched by a time clock. The Warmwell boiler has a remote stop/start loop which can be used to operate the boiler(s) under a timed regime. This remote loop requires a volt free contact for operation. Power is supplied by the boiler for this circuit to function. The voltage will therefore be the same as the boiler's power supply. Refer to Fig.11/Page 21 for typical site wiring connections. See **B.S. 6644** for further information. Do not modify this circuit in any way. See note in Fig No 11/Page 21 re: external voltages.

9.1 SITE WIRING

Access to the controls is achieved by rotating the ¼ turn latch and removing the door. A 20 mm dia. knockout is provided in each side panel for electrical connections (if required). Any other routing of site cables should ensure they do not pass close to the boiler flue hood or that any cable trunking does not interfere with normal air circulation and supply ducts.

A gland plate is supplied with every Warmwell HE boiler having two 20 mm dia. holes for electrical cable anchorage. A plug and socket arrangement is utilised for site connections. Care must be taken to ensure correct connections are made to the relevant terminals before applying power.

Refer to Fig.19,20,21 & 22/Pages 37,38,39 & 40 for typical wiring diagrams.

10.0 BOILER ASSEMBLY AND INSTALLATION

10.1 GENERAL

Each boiler is despatched to site as follows:-

- 1) Heat exchanger & basket including burners and gas valve(s) etc. on a pallet.
- 2) Casing complete with assembly instructions.
- 3) Control Assembly with relevant control

system.

4) 45° flue pipe.

5) Condensing section assembly (Fitted to item 1).

Further details of each individual assembly are given below:-

1) Factory tested heat exchanger casting assembly complete, including insulation wrap, gas valve assembly including pre-wired plug assembly. The gas connection pipe & insulation wrap is supplied separately and should be fitted to the boiler as shown. **THE GAS PIPE MUST NOT BE USED TO MANOEUVRE OR POSITION THE BOILER. NOTE!** Consideration must be given to the weight of the boiler (See Fig.2/Page 6), before lifting. It is recommended that the boiler is moved complete with pallet and positioned correctly. The pallet can then be dismantled and the boiler slid into position.

2) Casing including all screws, fasteners etc. to permit site assembly. Instructions are included in each box to show method of assembly. Two sizes are manufactured: small casing for the 60 and 95 boilers and large casing for the 140 boiler.

The condensing section casing is supplied separately. See Assembly instructions in Fig.9 & 9b/Page 17 & 18.

NOTE! When installing a multi-casing set the spacing plates must be used to correctly space the boilers approx. 3 mm apart prior to fitting the casing. (See label attached to the basket fixing.)

It is recommended that all mechanical work is carried out prior to fitting the casing assembly as this will reduce possible damage to the panels.

The casing assembly includes a component list which is also shown in Fig.9c/Page 19. You should check to ensure that all parts are supplied prior to assembly.

3) Controls assembly including fascia panel, thermostats, and pressure switch(es). This assembly will be suited for the desired controls variant and include any optional extras required. Refer to Fig.9/Page 17 for fitting instructions. Ensure all thermostat capillaries are inserted and correctly located into the top of the boiler. The controls assembly also incorporates a socket which matches the gas valve wiring plug. Care must be taken to ensure both plug and socket are correctly located and fixed in position by the screws provided.

4) A 45° flue elbow is supplied which locates in the stainless socket at the rear of the boiler. This elbow can be rotated through 180° to give vertical or horizontal flue discharge. Ensure the flue pipework is adequately sealed against condense leakage. In condensing mode the flue gases are saturated and will contain slightly acidic water which must be channelled into drains and not allowed to drip from seams.

The condensing section may be despatched separately, if required, and can be assembled onto the cast iron heat exchanger on site. Fig No. 8/Page 16 shows method of assembly. **Care must be taken in order not to damage the copper tubes or fan assembly during erection.**

All the necessary cabling and pressure pipes are supplied ready to attach to the controls housing when fitted. Please follow assembly instructions regarding these attachments as incorrect connection will result in commissioning problems at a later stage. See Fig No.12/Page 22 for further details.

10.2 CONNECTION OF BOILERS TO THE FLUE SYSTEM.

Notes on the recommendation for design of the flue system are given in Section 6:FLUE SYSTEM.

It is recommended that each individual condensing boiler has its own flue if possible. Due consideration should be given to obtain constant draught conditions if possible at the boiler discharge.

Flueways must be designed with continuous falls to low points where a suitable condensation trap should be fitted. All joints in the flue should be fitted such that condense drains into the preceding flue pipe without leakage.

Some of the flue may be under slight positive pressure therefore escaping vapour may condense on the outer skin of the flue. Again, all joints should therefore be suitably sealed against leakage.

Flues must be constructed with suitable materials to resist corrosion against the acidic nature of the flue gases. Materials used in the joints must also resist attack.

It is important, for service requirements, that the flue system is fully self supporting. Check the flue and chimney are clear from obstruction.

10.3 GAS CONNECTION

The Warmwell boiler is supplied with a gas pipe which exits the casing at the rear, see Fig.2/Page 6 for position. The incoming mains gas supply must be capable of supplying gas to the boiler at the required pressure, under all firing conditions. For sizing information see Fig.18/Page 36. An approved isolating valve & union should be installed for each boiler in a convenient and safe position and be clearly marked.

10.4 WATER CONNECTIONS

See Fig.2/Page 6 for position of water connections (flow and return). A ½" BSP. plug is fitted local to the return connection for the fitting of a drain cock, **NOTE!** (Not H.H.L. supply). Care must be taken when installing water system pipework that undue stress is avoided on the boiler flow and return connections. The return connection is fitted to the copper header on the heat exchanger. **WHEN ATTACHING PIPEWORK TO THIS HEADER IT IS IMPERATIVE THAT NO UNDUE STRESS IS PLACED ON THE 2" BSP CONNECTIONS.**

The header must be suitably supported when screwing in and tightening pipework to this header.

required pressure, under all firing conditions. For sizing information see Fig.18/Page 36. An approved isolating valve & union should be installed for each boiler in a convenient and safe position and be clearly marked.

10.4 WATER CONNECTIONS

See Fig.2/Page 6 for position of water connections (flow and return). A ½" BSP. plug is fitted local to the return connection for the fitting of a drain cock, NOTE! (Not H.H.L. supply). Care must be taken when installing water system pipework that undue stress is avoided on the boiler flow and return connections. The return connection is fitted to the copper header on the heat exchanger. **WHEN ATTACHING PIPEWORK TO THIS HEADER IT IS IMPERATIVE THAT NO UNDUE STRESS IS PLACED ON THE 2" BSP CONNECTIONS.**

The header must be suitably supported when screwing in and tightening pipework to this header. It is recommended that unions are fitted local to the

boiler to permit future servicing requirements. Fully closing valves must not be connected to both flow and return pipes unless the boiler is fitted with an individual, correctly sized, safety valve. It is recommended that a 3-way 'L' port valve is fitted in the flow connection to allow an open vent situation should the boiler need to be fully isolated from the system.

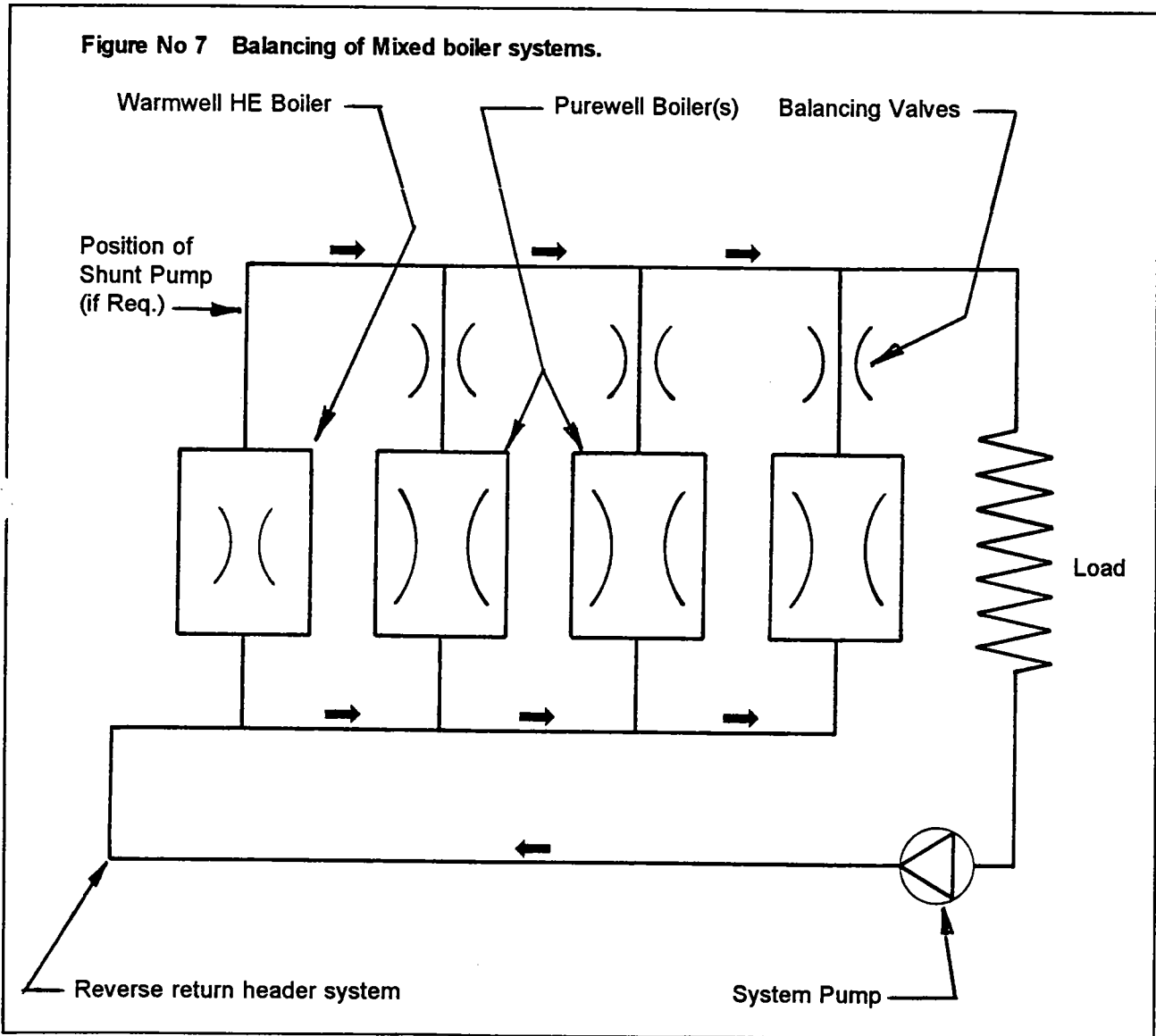

Figure No 8 Assembly of Secondary Heat Exchanger onto the Primary Heat Exchanger, if required.

The secondary & primary heat exchangers can be dispatched separately if required, and will require assembly on site.

This is achieved as follows:-

1) Carefully unpack secondary heat exchanger assembly. A flexible pipe assembly connects both heat exchangers together and is normally dispatched fitted onto the primary heat exchanger.

2) Ensure rope seal is aligned within rope groove on the top casting. Screw on four M8 nuts & washers onto the tie rods.

Gently lower the transition duct onto the top casting - ensure rope seal does not move. Fit M8 nuts & washers to restrain the assembly - **DO NOT**

TIGHTEN AT THIS STAGE. -

3) Connect the flexible pipe to the secondary heat exchanger and tighten - **TAKE CARE NOT TO DAMAGE OR PLACE UNDUE STRESS ON THE COPPER TUBES OR HEADERS.** Tighten nuts onto the transition duct. Do not over tighten otherwise lugs will be distorted. Lock M8 nuts together. Remove transition duct cover and visually inspect rope seal integrity.

4) Ensure all connections are water-tight starting at the base. Re-fit transition duct cover and continue installation.

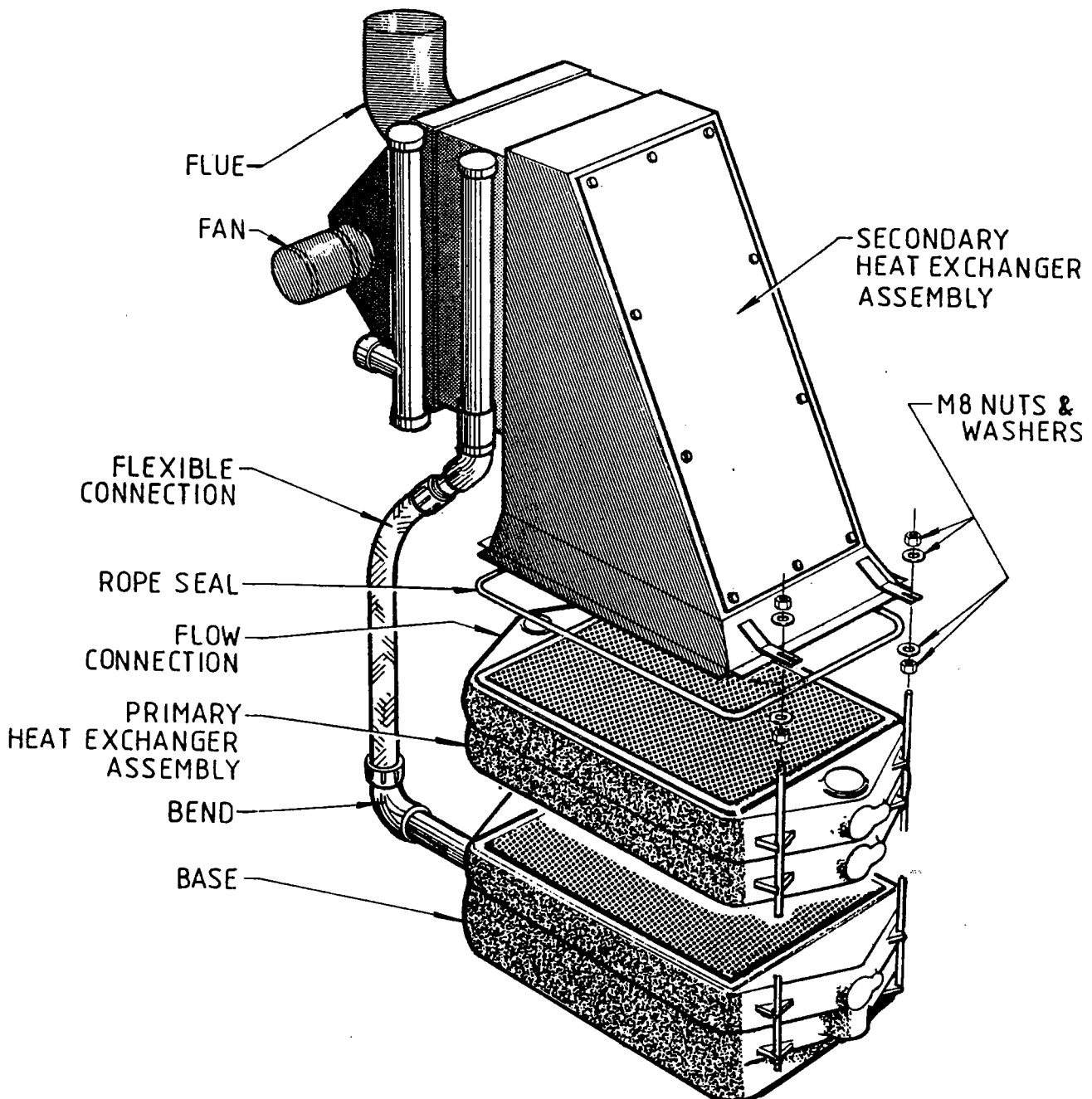

Multi-casing

Note: Where boilers are in Modular form rather than "Stand alone", a multi-casing pack is provided for each additional boiler lower casing in the group or bank, a triple boiler module will therefore need 1 off single casing pack plus 2 off multi-casing packs. The multi-casing pack does not contain side panels but has a casing support frame instead.

For multi-boiler installations the "support bar": (bottom rail of item 22), may already have been removed from the packs at the time of positioning the boilers. However, if the support bar is still in the packs the following procedure must be taken:-

- 1) Loosen the nuts that clamp the boilers together at the basket side plates (2 off - 1 front and 1 rear). Lift the bolt, spacer and nut assembly upwards out of the slots.
- 2) The support bar (item 22) can now be positioned between the boiler baskets. It is designed to fit any way round and either way up. The rear slot in the basket must line up with the end hole in the support bar. Discard the original temporary spacers and use the "pozi-pan head" screws (item 13) and M6 nuts (item 3) to secure.

- 3) Select item 22: the front member, top bar, and rear member, and fit the 'U' nuts (10 off item 4), the latch (2 off item 2) and door location brackets (2 off item 7) as shown opposite. The rear member uses 6 off 'U' nuts, (4 off in the two lower pairs of holes and 2 off in the angle bracket at the top).

Assemble the frame using the No 8 Self tapping screws (item 5) and M6 pan head screws and washers (items 12 and 13).

Single and multi-casings.

- 4) Select the Left hand (item 17) and Right hand (item 18) side panels and fit the 4 off latches (item 2), 4 off 'U' nuts (item 4) and 2 off door location brackets (item 7) as shown opposite using items 1 and 6. Only the two holes at the bottom of the rear edge of the side panels need 'U' nuts fitted. (An optional extended back panel is available which will utilise the other 'U' nut positions).

- 5) Locate and fix the side panels using items 3, 12, 13 and 14. Attach the back panel using 4 off screws (item 5) as shown opposite. **DO NOT TIGHTEN ITEM 5 AT THIS STAGE.**

- 6) Carefully unpack the control panel, there should be 1 off per boiler, and fit between the side panels and/or casing support frame using 4 off No. 8 x 1/2" self tapping screws (item 5) per control panel.

- 7) Select the condensing enclosure side panels (items 24 and 25) and fit the strikers (item 2) into the square holes. Ensure the blade runs 'front to back' to locate the latch. Lower the side panel and press the latch and striker together at the front and rear. Secure the cross mounting support rail (Item 26 for 95 & 140 models) or (Item 37 for 60 model) onto the top of the flue duct with the M6 nuts & washers provided. Fit the 'U' nuts to each end & secure with 2 off No.8 screws to both side panels. Holes are slotted to provide for squareness adjustment, tighten screws.

Fit L/Hand & R/Hand back panel brackets (Item 30 & Item 38) to both upper and lower side panels using 'U' nuts and 4 off No. 8 screws.

- 8) Tighten all the back panel screws and fit screw covers (part of item 14) to side panel screws.

Assemble pressure switch sensing tubes onto the sensing pipe assembly fitted to the flue outlet plenum chamber (local to fan). The top pressure switch connection(s) fit onto the tapping nearest to the flue outlet. The bottom pressure switch connection(s) fit onto the tapping nearest to the secondary heat exchanger headers. (see Fig.12/Page 22).

Connect the fan plug/socket to the controls unit as shown in the relevant wiring diagram. See Fig No 19,20,21 or 22 for details (pages 38-41).

- 9) Attach 4 off spacer sets (items 33 and 34) and 2 off spring latches (items 35 and 36) into top panel (item 27) and press onto top of casing.

Attach 4 off spacer sets (items 33 and 34) and 2 off spring latches (items 35 and 36) into sloping front panel (item 29) and press onto front of casing.

- 10) Ensure thermostat bulbs are correctly fitted and located into boiler pocket. Fit 2 off spacer sets (items 33 and 34) and 2 off 'U' nuts into short top panel. Locate into side casing and secure with 2 off No. 8 screws.

- 11) Locate control plug on gas valve. Push into control housing firmly. Affix with screws provided.

- 12) Select the door and attach the location pins (item 8) to the two holes in the 25mm return by using M4 x 20 pan head screws (item 9), washers (item 11) and nuts (item 10). To fit the door, locate the two slotted holes in the bottom onto the location brackets (item 7). Close the door against the control panel fascia ensuring the locating pins enter the pierced holes. Turn the 1/4 turn latch in the centre of the door to lock.

- 13) Fit & connect the condense trap as required. **Note!** the condense trap is a siphonic unit and will pass condensed water in pulses. Two terry clips are supplied which can be used to attach the trap to the lower casing back panel if required. Otherwise site the trap in a suitable position to ensure condensed water passes down a local tundish. **Note!** The condense trap is made from plastic and care should be taken in handling and positioning the unit.

Figure No 9b

Exploded View of Warmwell/Purewell Casing Set

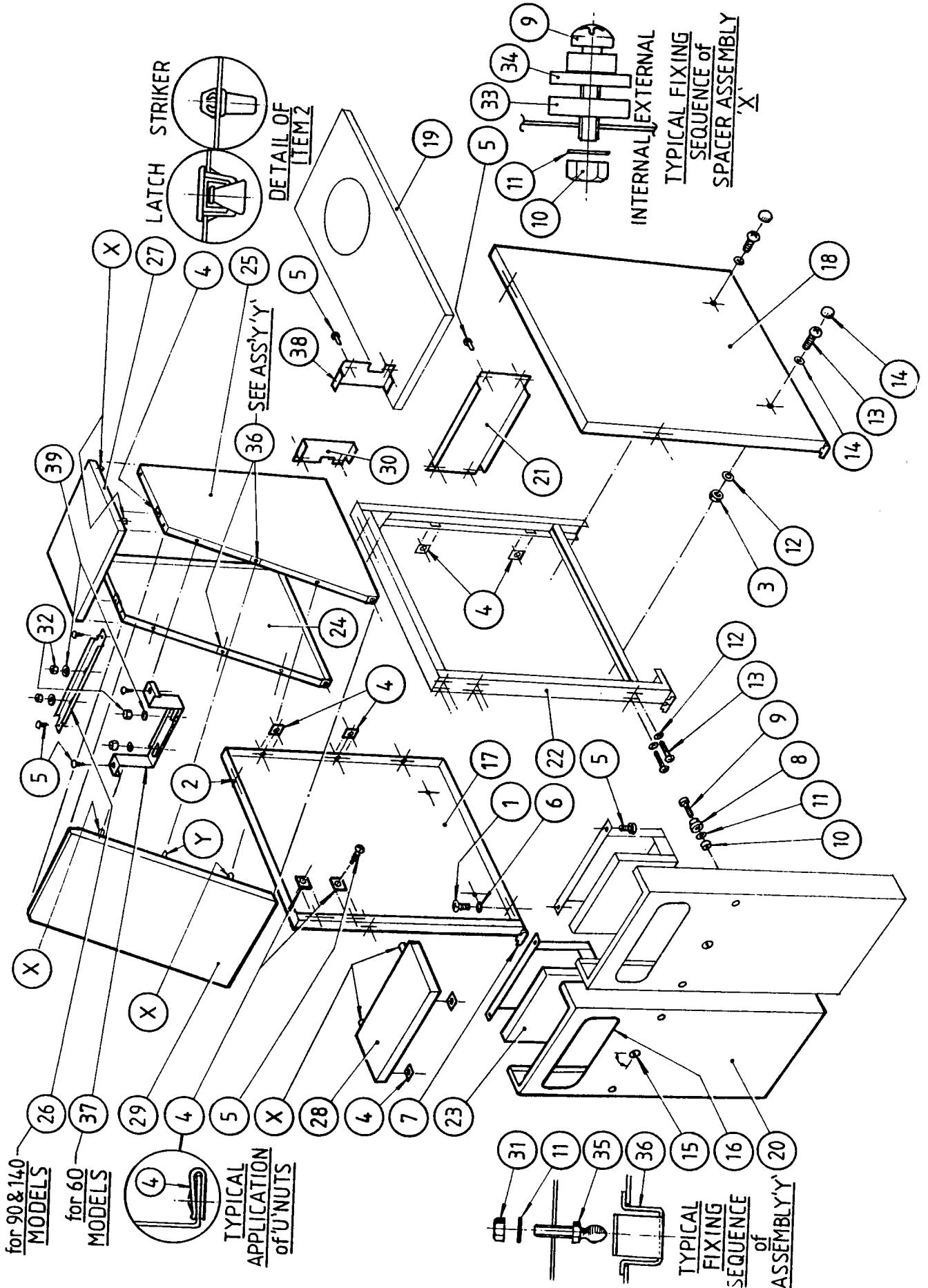

Figure No 9c Inventory of Warmwell HE/Purewell casing set.

NOTE!.....* = Single Casing Set ** = Multi-casing Set

Purewell Primary heat exchanger casing assembly.

Item	Description	No *	No **	Item	Description	No *	No **
1	M5 x 6 Pan.Hd Screw	4	4	12	M6 Int. Shakeproof Washer	4	6
2	Latch and Striker	2	2	13	M6 x 16 Pan. Hd. Screw	4	6
3	M6 Nut	4	2	14	M6 Screw Cover	4	-
4	'U' Nut for No. 8 Screw	10	16	15	Latch Assembly	-	-
5	No.8 x ½" Self tap. Screw	10	16	16	Door Edging	-	-
6	M5 Spring Washer	4	4	17	L.H. Side Panel	1	-
7	Door Location Bracket	2	2	18	R.H. Side Panel	1	-
8	Nylon Door Location Pin	2	2	19	One Piece Top Panel	1	1
9	M4 x 20 Pan. Hd. Screw	2	2	20	Door	1	1
10	M4 Nut	2	2	21	Back Panel	1	1
11	M4 Shakeproof Washer	2	2	22	Top, Front, Rear & Support Bars	-	1 ea.

Warmwell HE Secondary Heat Exchanger Casing Assembly

2	Latch and Striker	2	2	31	2 BA Nut	4	4
4	'U' Nut for No. 8 Screw	6	6	32	M6 Nut	4	4
5	No.8 x ½" Self tap. Screw	6	6	33	Plastic Washer	10	10
9	M4 x 20 Pan Hd. Screw	10	10	34	Stepped Spacer	10	10
10	M4 Nut	10	10	35	Ball Catch	4	4
11	M4 Shakeproof Washer	10	10	36	Door Catch	4	4
24	L.H. Side Panel	1	1	37	Side Panel Support (60)	1	1
25	R.H. Side Panel	1	1	38	R/Hand Casing support Bkt.	1	1
26	Side Panel Support (95/140)	1	1	39	M6 Washer	4	4
27	Top Cover	1	1				
28	Front Cover	1	1				
29	Sloping Front Cover	1	1				
30	Back Panel	1	1				

Note! Item 19 (One piece top panel) is not used on Warmwell HE Condensing Boiler.

Item 26 is used on the 95 & 140 models only, & Item 37 is used on the 60 model only.



HAMWORTHY

heating products

Figure No 10 General Layout (Front View).

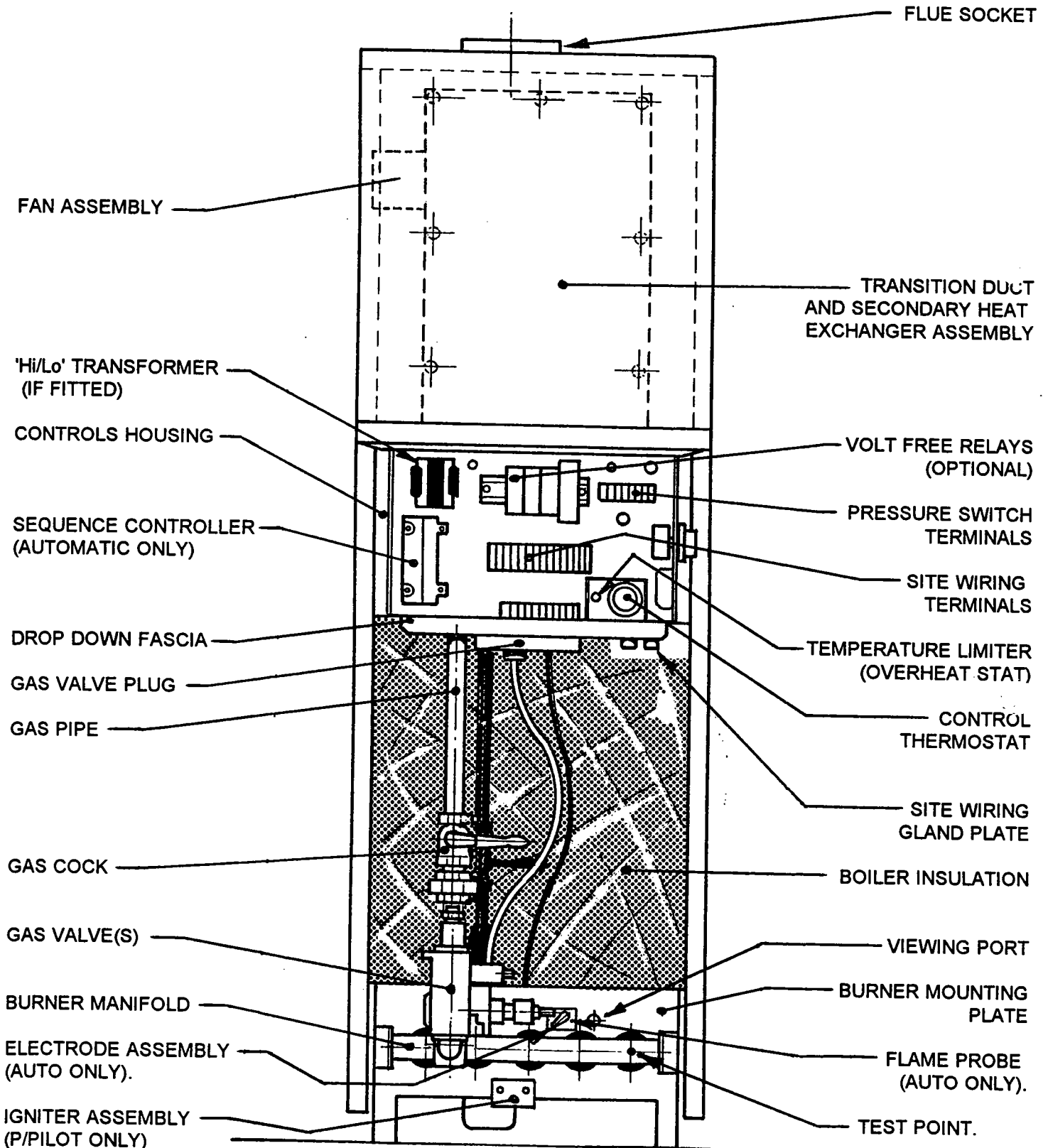



Warmwell HE Condensing Boiler Site Wiring Diagram

Wire colour	Terminal ident.	Function
Red/Brown	C3	High/low control loop (Closed for High fire) (Automatic Only)
Red/Brown	C4	
Black	C1	Flame probe test loop (Automatic Only)
Black	C2	
Pink	3	Remote control On/off loop
Pink	4	
Red/Green	15	Overheat loop (Automatic only)
Red/Green	16	
Yellow/Red	17	
Yellow/Red	18	Lockout indication loop
Pink/Black	19	
Pink/Black	20	Boiler on indication loop
White/Red	21	
Red	Live	Pump Terminal (Marshall only)
Blue	Neutral	
Green/Yellow	Earth	
		Live 230 Volt AC 50 Hz
		Neutral line
		Earth line

Volt free contacts (Optional) *

NOTE!....Maximum rating of a volt free contact(s) is : 3 Amperes Resistive

WARNING! External voltage MUST NOT be applied to remote stop/start terminals 3 & 4 or high/low control loop terminals C3 & C4 or any terminals on the fascia.

NOTE! * Volt free contacts may have separate supply. Ensure all power supplies are completely isolated prior to working on the electrical circuits of this appliance.



HAMWORTHY

heating products

Fig No 12 Pressure Sensing Tube/Fan Plug Assembly

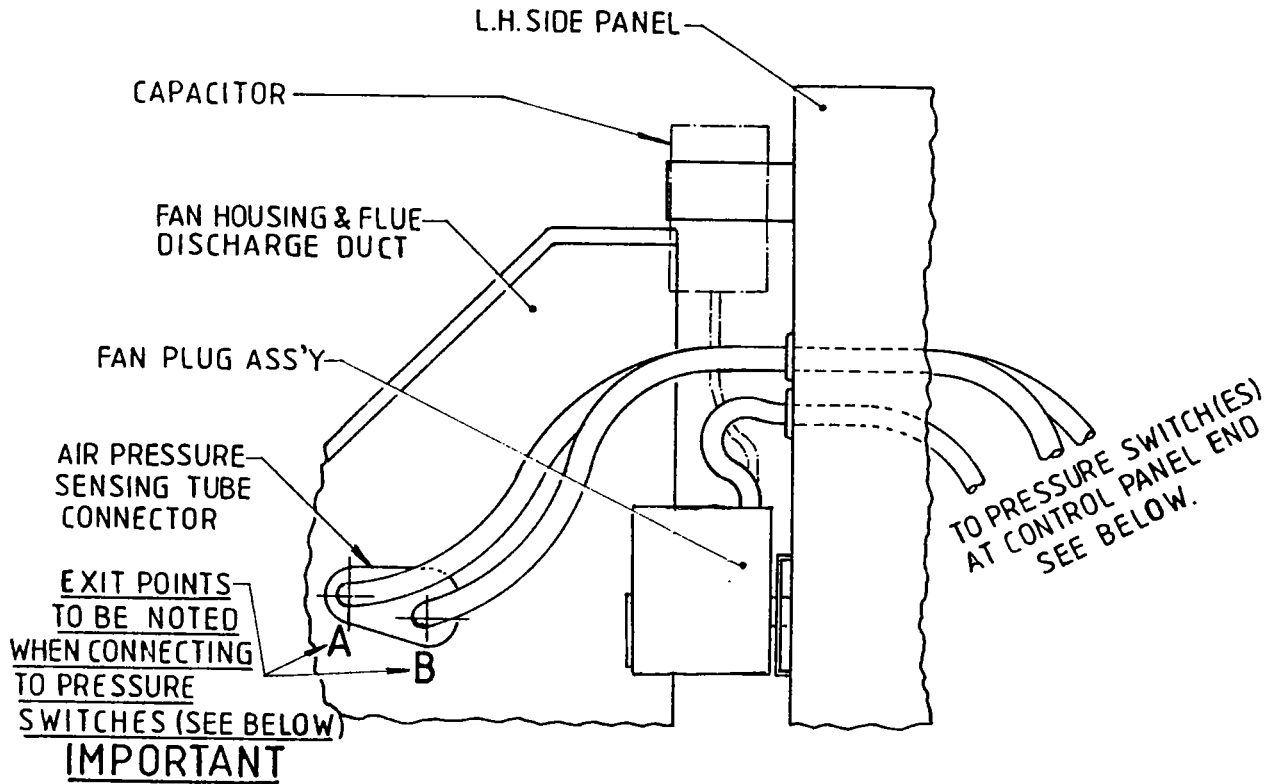

SIDE VIEW of FAN PLENUM CHAMBER

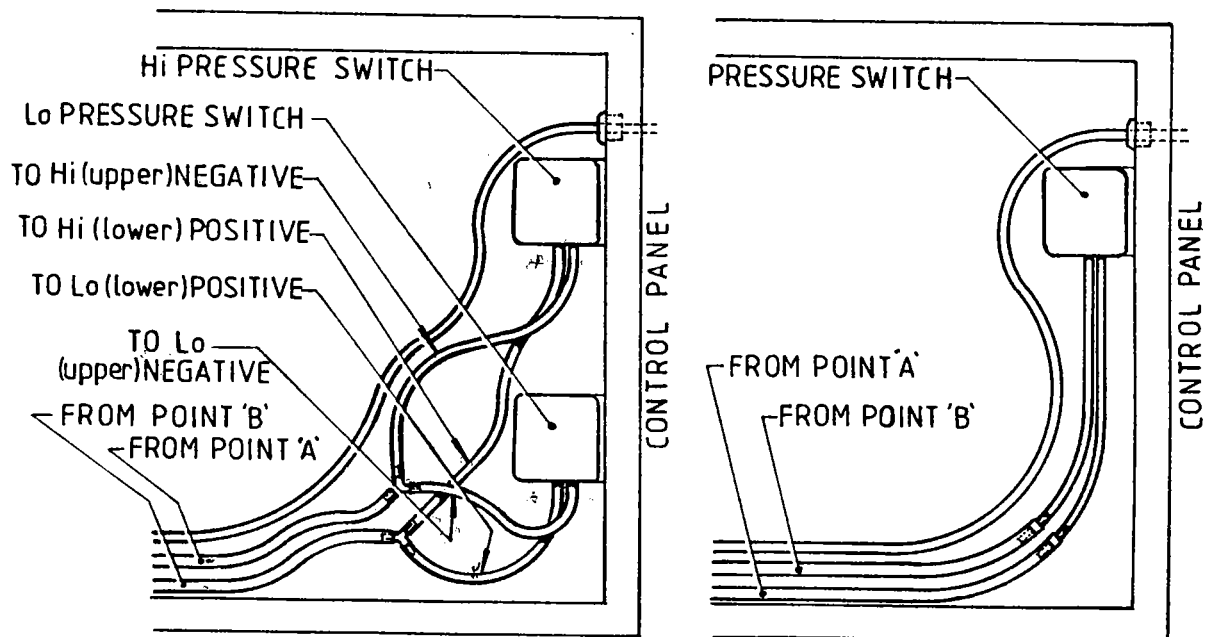

PLAN VIEWS of PRESSURE SWITCH CONNECTIONS

Hi-Lo

BASIC

11.0 COMMISSIONING AND TESTING

11.1 ELECTRICAL INSTALLATION

Wiring **MUST** be checked by a suitably competent person. Power supply required is 230 volts 50 Hz single phase. An isolator correctly fused at 6A. should be sited close to the boiler.

Access to the controls is achieved by rotating the ¼ turn latch and removing the door. Connections to the boiler should pass through the 2 x 20 mm wiring gland plate. The boiler is supplied with a remote stop/start circuit for time clock operation. **Any other interlocks, ie. Pressurisation unit, B.E.M. System should be wired in series with the remote stop/start loop.**

The site wiring terminal rail is marked with Live, Neutral and Earth connections. See Fig.11/Page 21 for details. **IMPORTANT READ THE WARNING NOTE REGARDING EXTERNAL VOLTAGES.** It is a plug/socket type terminal rail and can be unplugged for wiring if required.

A schematic of the control circuit is shown in Fig.19/Page 37 (Pilotstat), Fig.20/Page 38 (Permanent Pilot) & Fig.21 & 22/Pages 39 & 40 (Automatic).

The fan motor will be pre-wired to a suitable plug/socket assembly. The 3 core cable must be connected to the controls assembly as shown in the wiring diagrams. The connections are brown wire to terminal 8, blue wire to neutral, and green/yellow wire to earth.

11.2 GAS INSTALLATION

For design see Section 5:GAS SUPPLY.

The whole of the gas installation including the meter must be inspected and tested for soundness and purged in accordance with the recommendations of BS 6891 or IM/2 or IM/5 as appropriate.

11.3 WATER CIRCULATION SYSTEM

For design see Section 8:WATER SYSTEM.

The system should be thoroughly flushed out with cold water without the pump in position. Ensure all the valves are open.

With the pump fitted the system should be filled and air locks cleared. Vent the radiators and check for leaks.

If the system is unvented the pressurisation unit should not be utilised for the initial filling. This should be carried out using a W.R.C. approved double check valve and temporary filling loop. In order to comply with local Water Authority Regulations, this loop must be disconnected when filling is complete. Water treatments should not be fed through the pressurisation unit unless permitted by the manufacturer. Check the expansion vessel cushion pressure as detailed by the manufacturer's Installer's Guide.

11.4 COMMISSIONING THE BOILER (Permanent Pilot and Automatic)

Before attempting to commission any boiler, ensure that personnel involved are aware of what action is about to be taken and begin by making the

following checks:-

- 1) Flueway passages to chimney are clear.
- 2) If necessary, remove the inspection cover and ensure the boiler flueways are clear. Ensure secondary heat exchanger passages are clear and clean. Re-fit the cover.
- 3) Adequate ventilation as per Section 7: **AIR SUPPLY** exists in the boilerhouse.
- 4) The system is fully charged with water, ready to receive heat. All necessary valves are open and the pump is circulating water. Ensure secondary heat exchanger is purged of air.
- 5) The pipework and valve arrangement is installed to Hamworthy Heating recommendations in such a way that water flow rates will be in accordance with Fig.4/Page 9.
- 6) The gas supply pipework is clear of any loose matter, tested for soundness and purged to CP:331/3.

11.4.1 BOILER CHECKS PRIOR TO LIGHTING (Automatic and Hi/Lo Only)

NOTE! Refer to Fig.3/Page 7 for maximum gas inlet pressure for normal operation.

1) Gas supply is connected but turned to the "off" position. Any unions or fittings are correctly tightened, test points are closed, burners correctly positioned, injectors are in place (of correct size) and tight and that the ignition and probe leads are connected correctly. Ensure ignition assembly electrodes are not cracked or broken.

2) Ensure electricity is connected and 2A. fuse on boiler removed, the plug/socket gas valve connection is correctly located and fully tightened with screws provided and that the thermostat bulbs are fully inserted into the pocket. Reset temperature limiter by firmly pressing pin (in controls housing.)

3) Check setting of both temperature limiter and control thermostat. The temperature limiter must be set at 100°C maximum to comply with the European Standard requirements. Set control thermostat to required temperature. Ensure limits are set if required. Set Hi/Lo thermostat to required temperature (if fitted). This is generally set 3 - 5°C below control thermostat temperature.

4) Drop down fascia on controls housing to reveal the main terminal rail. Fig.11/Page 21 shows the correct location of incoming wires. Remove link on terminals C1 and C2 (black wire) and insert a multi-meter set to read D.C. μ A.

Figure No 13 Diagram of Automatic Gas Valves

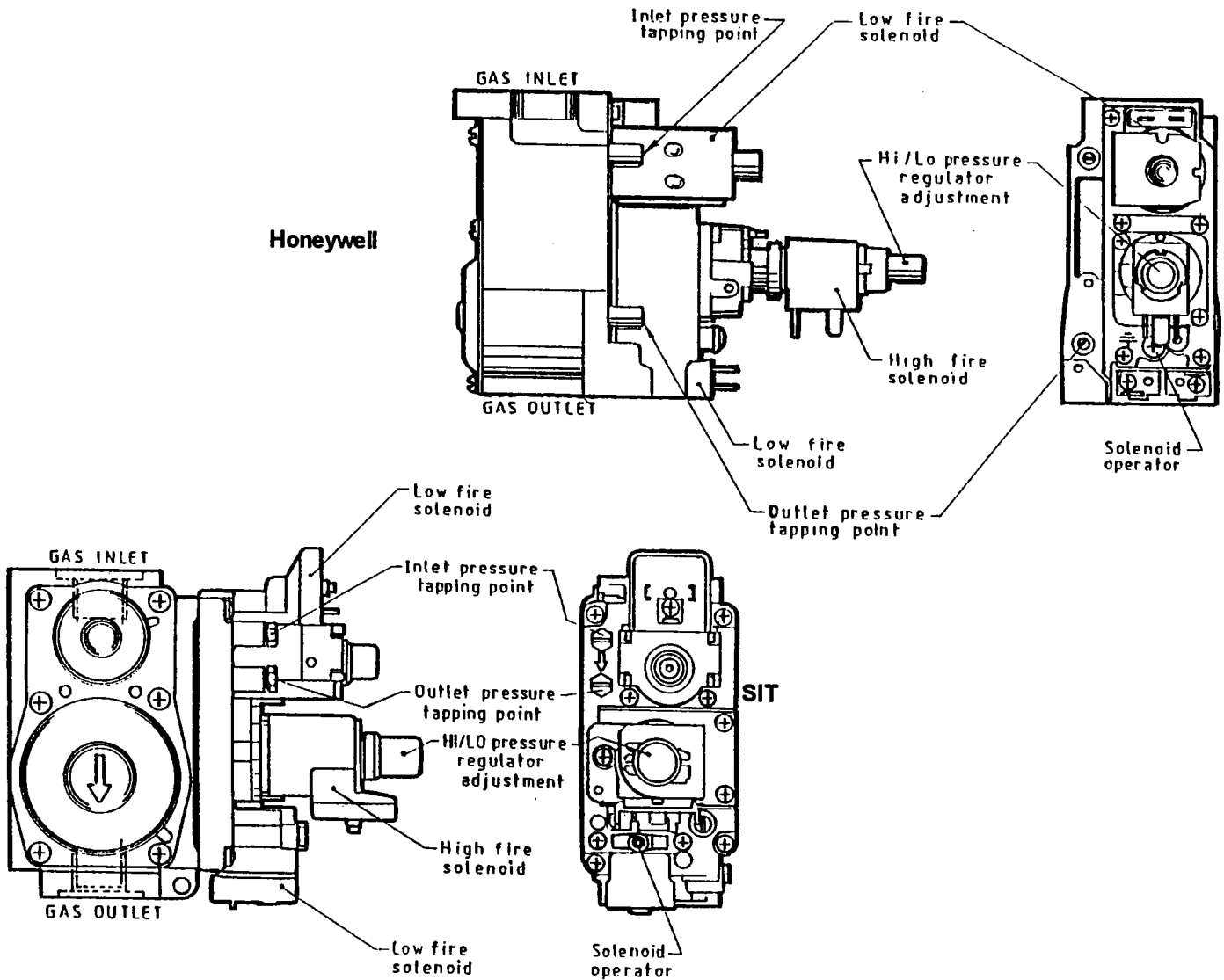

ADJUSTMENT PROCEDURE.

Refer to Fig 3/Page 7 to find the low fire/start and high fire gas pressures for the boiler being fired.

Fit a manometer (suitable for 30 mbar) onto manifold test point.

Light up the boiler. Then remove the protective cover from the Hi/Lo pressure regulator.

To adjust the high fire gas pressure, turn the outer nut on the hi/lo pressure regulator.

To adjust the low fire/start gas pressure, remove link on terminals C3 and C4, nominally set the low fire/start gas pressure by rotating the inner

crosshead screw, whilst keeping the outer nut from rotating. Turn the boiler off then on again and fine trim the gas pressure.

Insert or make the high fire link on terminals C3 and C4; the boiler should drive to high fire. Replace the protective cap on the Hi/Lo pressure regulator.

Note! The low fire setting must always be set last of all. The valves operation may be incorrect if this is omitted.

Note! It is also advisable to carry out this procedure with all boilers firing. The long term reliability of the ignition system may well be reduced unless this procedure is carried out correctly.



HAMWORTHY

heating products

Figure No 14 Diagram of 'Hi' Flow Gas Valve Assembly

PUREWELL 95 - 120 kW Automatic &
WARMWELL HE 140 Automatic.

The 'Flowshare' gas valve assembly is designed to pass the correct quantity of gas at the nominal inlet pressure of 20 mbar and a maximum inlet pressure of 25 mbar.

Refer to Fig.3/Page 7 to find low fire/start and high fire gas pressures for the boiler being fired.

Fit a manometer (suitable for 30 mbar) onto gas manifold pressure tapping point.

Light the boiler. Remove protective cap from the Hi/Lo pressure regulator.

Turn the Hi/Lo valve high fire rate adjuster (outer nut) clockwise until the pressure stops increasing. Loosen Throttle locking nut (if fitted) and rotate the throttle valve adjuster screw until the manifold pressure is approx. 0.5 mbar greater than the required high fire gas pressure.

Tighten the locking nut (if fitted) on the throttle adjuster screw.

Turn the Hi/Lo valve high fire rate adjuster anti-clockwise to fine trim the high fire pressure.

Refer to Fig.13/Page 24 for procedure on how to adjust valves for correct low fire/start gas pressures.

NOTE! Honeywell valves shown in diagram.

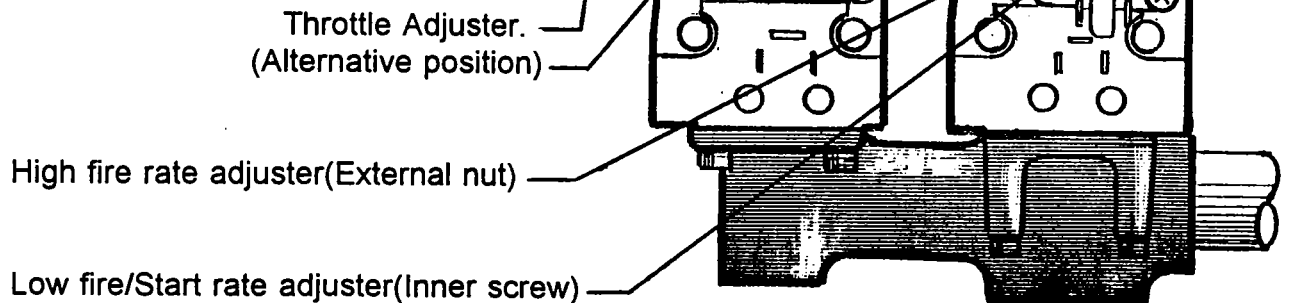



HAMWORTHY
heating products

Figure No. 15 Pilotstat Valve Assembly

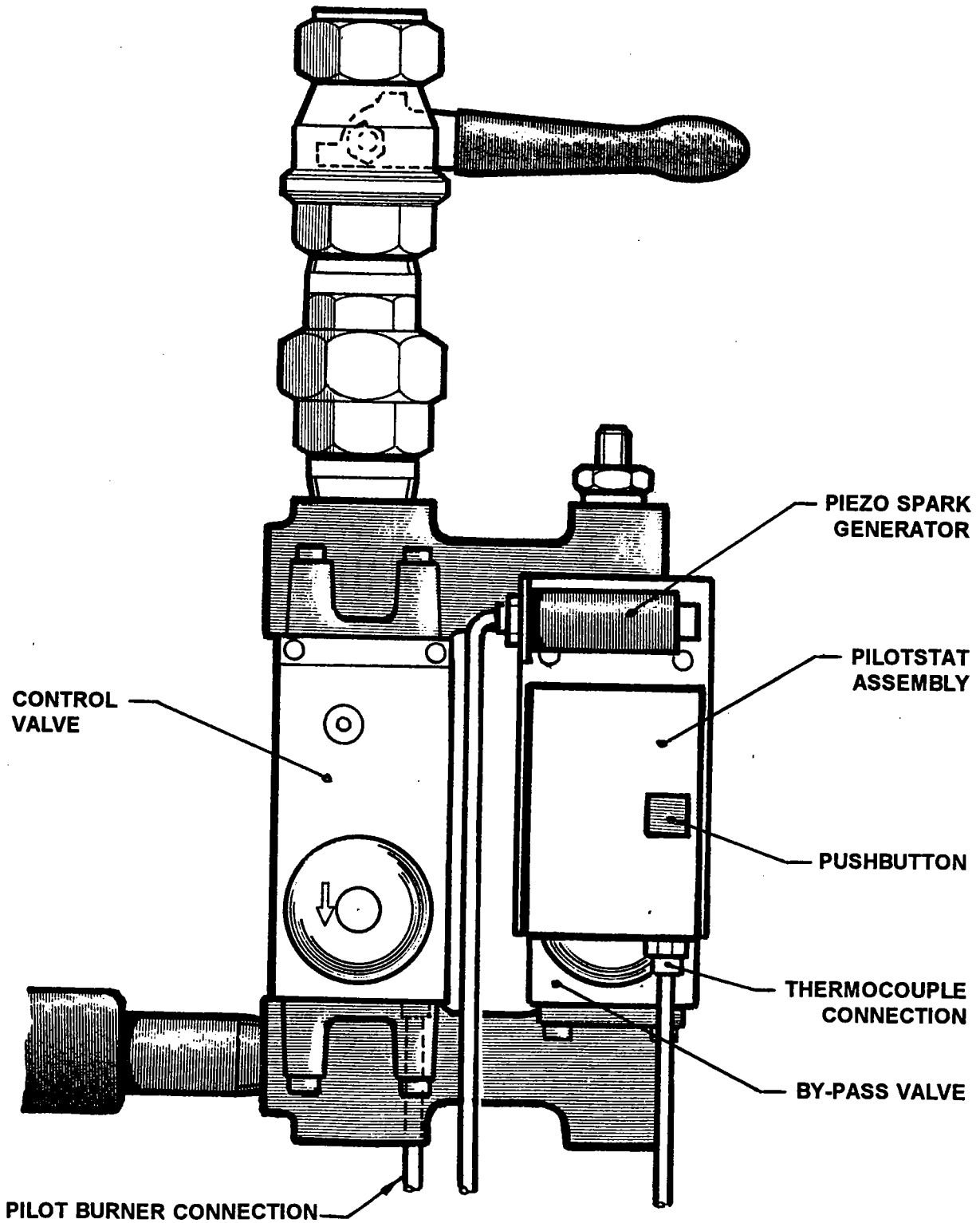

5) The Warmwell HE fully automatic boiler utilises a low fire start gas rate ignited by direct spark ignition (D.S.I), see Fig.16/Page 28. To ascertain which type of gas valve is fitted, refer to Fig.13/Page 24. The method of low fire and high fire adjustment is explained on this data sheet. You should familiarise yourself with this procedure for use later when required.

Ensure pressure switch sensing tubes are correctly fitted, without twists or kinks. Refer to Fig.3/Page 7 for provisional pressure switch setting(s). Refer to Fig.12/Page 22 for position.

11.4.2 PROCEDURE FOR INITIAL LIGHTING (Automatic and Hi/lo)

Ensure gas service cock is in the "off" position. Replace 2A. fuse in fascia. Press lockout button on fascia to re-set timer (wait at least 15 seconds before pressing again if lockout neon does not go out. The induced draught fan will start and run for a pre-purge period (approximately 10 seconds). During this time the 'fan on' neon should illuminate showing 'pressure proved'. After a delay the spark should be heard across the electrodes. As the gas service cock is closed, the controls should go to lockout after approximately 3 seconds (amber neon on fascia lit). If the above occurs correctly, open service cock and press re-set button on fascia.

After the pre-purge period the ignition should be heard and main gas valve will energise lighting the main burner. Turn the control thermostat to the required flow temperature. **Note!** the multi-meter should be reading at least 1 μ A (Honeywell controller).

11.5 After the boiler has operated for approximately 10 minutes, remove the 2A. control fuse on the fascia. If necessary adjust low fire/start and high fire gas pressures. Refer to Fig.13/Page 24 for adjustment procedure of relevant gas valve fitted.

The Warmwell HE boiler is designed to conform to the requirements of the Gas Appliance (Safety) Regulations(1992). Therefore the gas pressure governor control system is configured for a nominal gas inlet pressure of 20 mbar with a maximum inlet pressure of 25 mbar. The 140 Warmwell boiler is fitted with the patented flow share gas valve arrangement. Refer to Fig.14/Page 25 for adjustment procedures. **NOTE!** The by-pass valve throttle **MUST** be used as the coarse gas pressure adjuster, the main control **MUST** always be accomplished by the high/low control valve. For the 60 & 95 Warmwell HE models see Fig.13/Page 24 for adjustment procedures.

Remove manometer and close pressure test point. Record all readings for future reference on the relevant commissioning sheet. Allow system to warm up sufficiently to check operation of control thermostat.

11.6 Check temperature limiter setting. This can be achieved by removing plastic cover (unscrewing) if fitted. Undo holding nut and withdraw into the controls housing. Adjust if required and refit in reverse order to that above.

A combustion check must be taken when first commissioning the boiler. **NOTE!** Care should be exercised if the boiler is firing as the flue can achieve temperatures which can produce injury if touched.

Combustion figures should be as follows:-

CO₂ = 7-8% condensing or 8-9% non-condensing (Dry flue gas).

CO = 0-50 ppm: however figure should not exceed 200 ppm under normal operating conditions.

11.7 To check for correct operation of the controller, remove multi-meter μ A link (Terminals C1 and C2): the boiler should lockout after approximately one second. Check that the flame has been extinguished. Remove multi-meter and replace wire link. Wait at least 15 seconds before pressing re-set button on fascia to re-set controller. After a waiting period the boiler will light and run normally.

11.8 When the above is complete, the boiler owner or their representative should be made aware of the lighting and operating instructions fitted to the inside of the boiler door. A practical demonstration should be given describing each functional step. This Installer's Guide and user's instructions should then be handed over and be kept in a safe place for easy reference.

11.9.1 BOILER CHECKS PRIOR TO LIGHTING (Permanent Pilot Only) All models

NOTE! Refer to Fig 3/Page 7 for maximum gas inlet pressure for normal operation.

1) Gas supply is connected but turned to the "off" position. Any unions or fittings are correctly tightened, test points are closed, burners correctly positioned, injectors are in place (of correct size) and tight and that the pilot is connected to the gas valve.

2) Ensure electricity is connected and 2A. fuse on boiler is removed, the plug/socket gas valve connection is correctly located and fully tightened with screws provided and that the thermostat bulbs are fully inserted into the pocket.



HAMWORTHY heating products

Figure No 16

Diagram of Igniter Assemblies

AUTOMATIC IGNITION

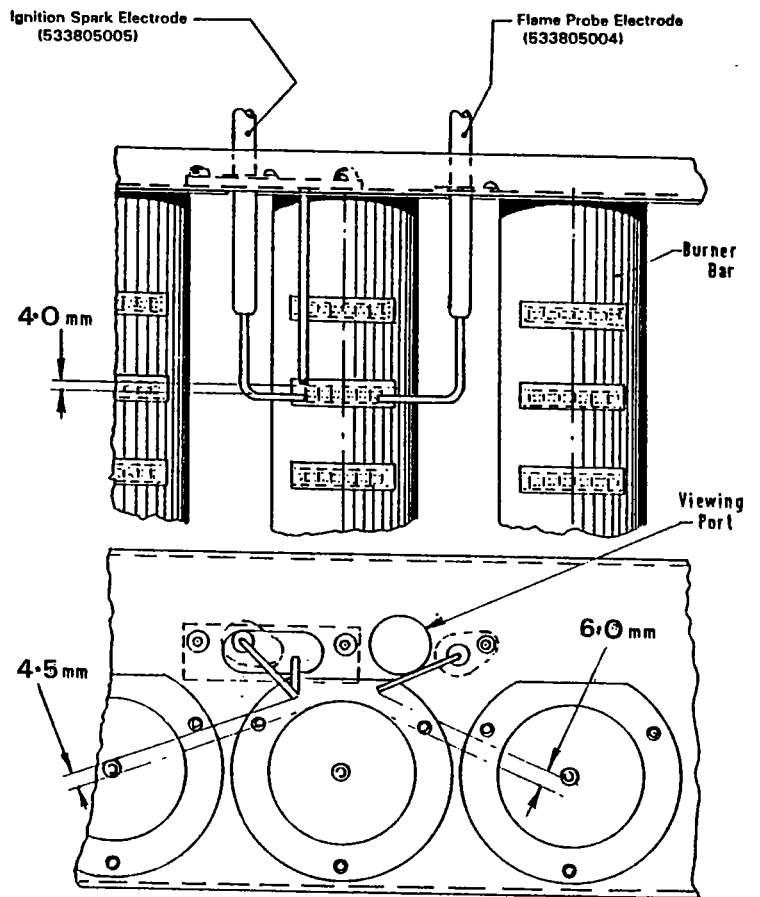

PERMANENT IGNITION

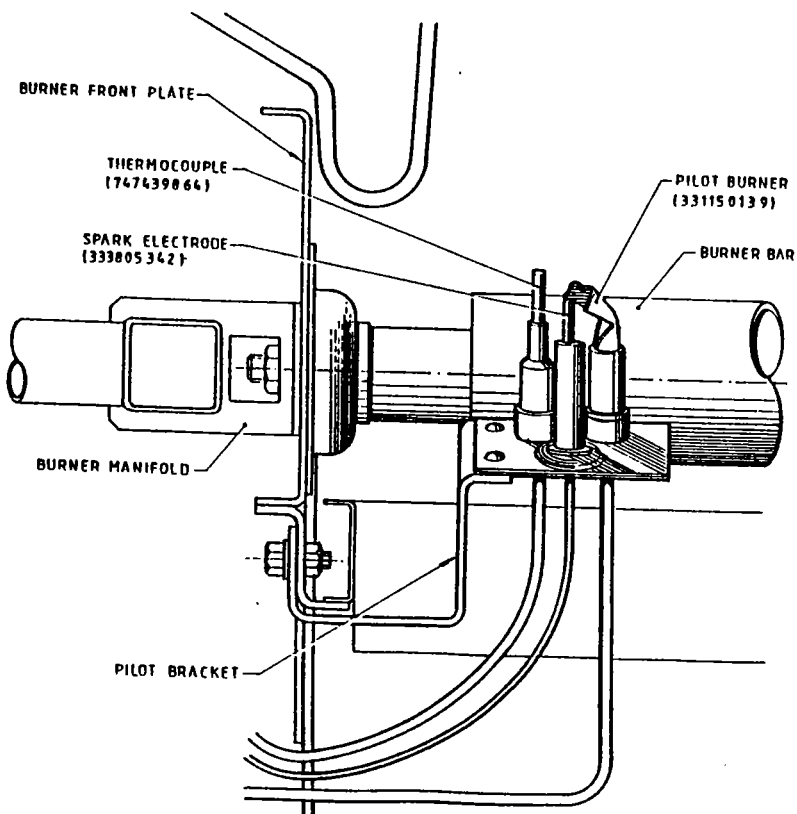

Ensure the thermocouple is connected between gas valve and pilot burner.

3a) **60 and 95 models only.** Energy cut-off (ECO) connector is correctly located between valve and thermocouple. Check the leads for damage and that they are firmly fitted to the temperature limiter (high limit) thermostat. Re-set temperature limiter by firmly pressing pin on unit.

3b) **140 model only.** Ensure thermocouple is secured to the pilotstat assembly. A standard automatic temperature limiter circuit is used on this model, ECO and gold plated limiter are not required. Please refer to relevant spares chart for specific thermostat required. Reset temperature limiter by firmly pressing pin on unit. See Fig.15/Page 26 for information.

4) Ensure the Piezo unit is fitted securely on its bracket and the lead is undamaged and correctly located.

5) Check setting of both temperature limiter and control thermostat. The temperature limiter must be set at 100°C. to comply with the European Standard. Set control thermostat to required temperature and ensure limits are set if required.

Ensure pressure switch sensing tubes are correctly fitted, without twists or kinks. Refer to Fig.3/Page 7 for provisional pressure switch setting(s). See Fig.12/Page 22 for position.

11.9.2.1 PROCEDURE FOR INITIAL LIGHTING (Permanent ignition) 60 and 95 models only.

WARNING: If the pilot light is extinguished either intentionally or unintentionally, **NO** attempt should be made to re-light the pilot until at least 3 minutes have elapsed. **This delay is for safety reasons and MUST not be ignored.**

Ensure electricity supply to the boiler is off. ie (2A, fuse on fascia is removed). Turn control thermostat to minimum!

Light pilot burner by repeatedly pressing the button on the piezo unit whilst pushing/twisting the 'start' button on the control valve fully in. (See Fig.17/Page 30 for valve description). Hold the button in for a further 20 seconds once the pilot is seen to light. Release button slowly. The pilot burner should remain alight. If however it goes out, push in the 'stop' button and wait 3 minutes before repeating above procedure.

If the pilot does not light after repeatedly operating the piezo unit for several seconds, re-vent the gas line to the outside of the building. Check whether spark and gas are present at the pilot. (See Section 12:FAULT FINDING). Having established the pilot, release the 'start' button and remove the pilot adjustment cover screw on the gas control valve. (See Fig.17/Page 30) for relevant gas valve fitted).

Adjust the pilot screw so that the flame envelops the tip by approx. 12 mm. After pilot adjustment, check time clock circuits (if fitted) are closed. Replace 2A. control fuse on fascia. Adjust control thermostat to the required temperature. The induced draught fan will start and run for a pre-purge period (approx. 10 seconds). During this time the 'fan on' neon should illuminate showing 'pressure proved'. The gas valve

should open and main burner ignite.

11.9.2.2 PROCEDURE FOR INITIAL LIGHTING (Pilotstat Permanent ignition model 140 Only).

WARNING: If the pilot is extinguished either intentionally or unintentionally, **NO** attempt should be made to re-light the pilot until at least 3 minutes have elapsed. **This delay is for safety reasons and MUST not be ignored.**

Ensure electricity supply to the boiler is on and the 2A fuse on fascia is inserted. Turn control thermostat to minimum!

Refer to Fig.15/Page 26 for positions of PilotStat button etc. To Light the pilot press the pushbutton marked 'pilot gas valve' on the fascia whilst operating the piezo unit. Once the pilot has lit, stop pressing the piezo spark unit and depress the red button on the pilot stat unit. After approximately 20 seconds release the Pilotstat button and then the fascia pushbutton. The lockout indicator should be 'off' at this stage. If the neon lights again **NO** attempt should be made to re-light the pilot until at least 3 minutes has elapsed. **This delay is for safety reasons and MUST not be ignored.**

Adjust the pilot screw so that the flame envelops the tip by approx. 12 mm. After pilot adjustment, check time clock circuits (if fitted) are closed. Adjust control thermostat to required temperature. The induced draught fan will start and run for a pre-purge period (Approx 10 seconds). During this time the 'fan on' neon should illuminate showing 'pressure proved'. The gas valve should open and main burner ignite.

11.10 After the boiler has operated for approximately 10 minutes, remove the 2A control fuse on the fascia. Open the pressure testpoint screw on the burner manifold and fit a manometer (suitable for 30 mbar). Check gas pressure reading against that shown in Fig.3/Page 7. Adjust servo pressure regulator as required by removing cap and turning with a screwdriver. Refer to Fig.15/Page 26 for details of particular gas valve type fitted.

Remove manometer and close all pressure test points (replace caps if fitted). Record all readings for future reference on relevant commissioning sheet. Allow system to warm up sufficiently to check operation of the control thermostat.



HAMWORTHY

heating products

Figure No 17 Diagram of Honeywell/SIT Permanent Pilot Gas Valves

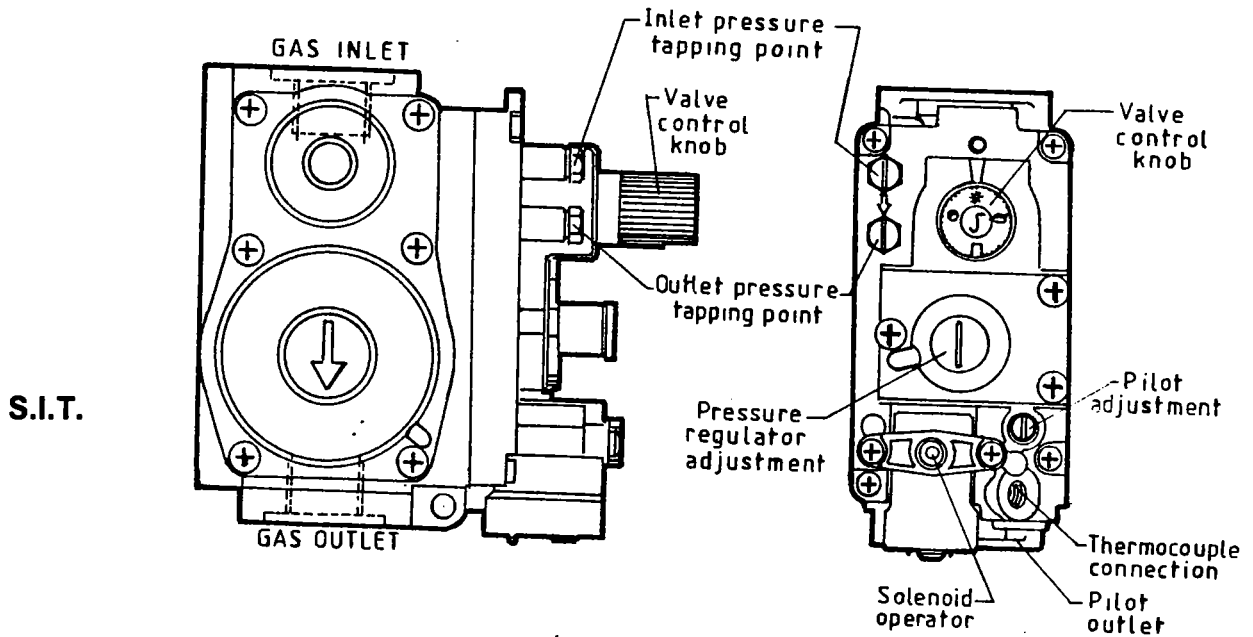
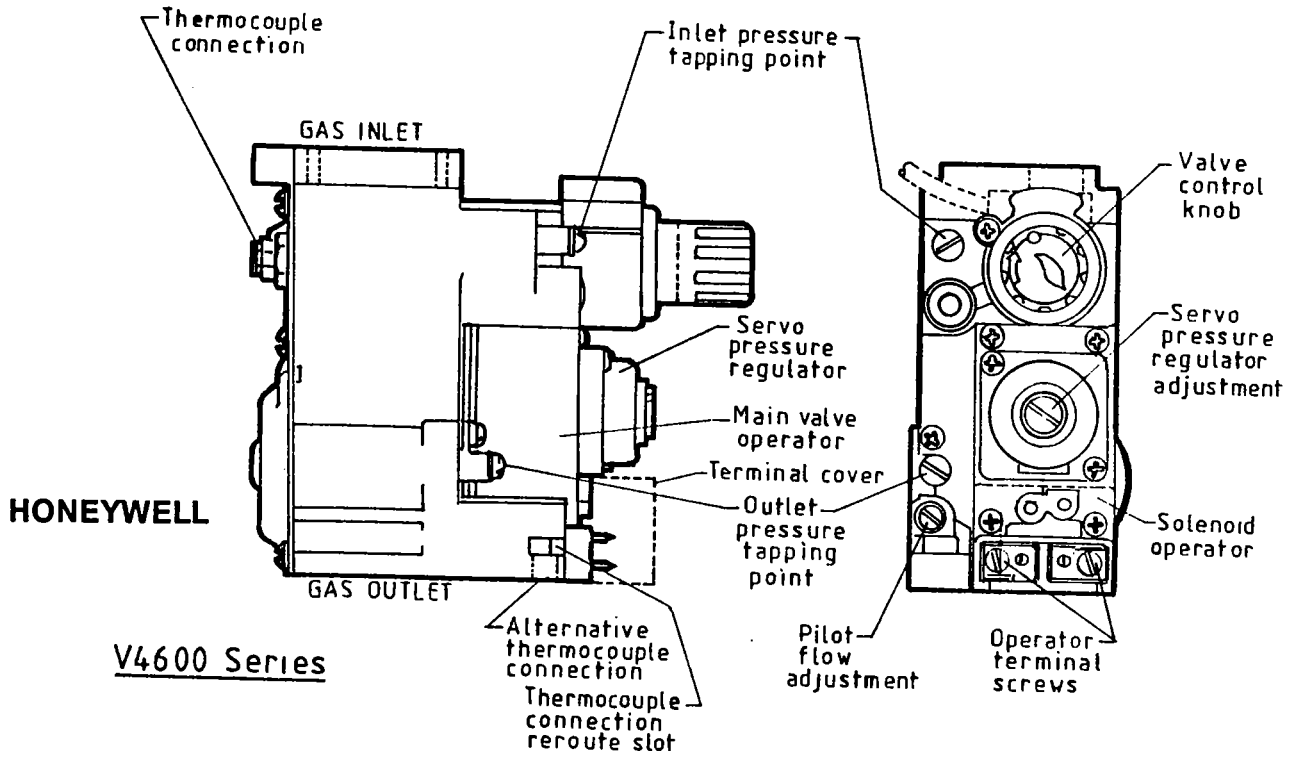

11.11 Check temperature limiter setting. This can be achieved by removing plastic cover (unscrewing) if fitted. Undo holding nut and withdraw into the controls housing. Adjust if required and replace in reverse order to above.

A combustion check must be taken when first commissioning the boiler. **NOTE!** Care should be exercised if the boiler is firing as the flue can achieve temperatures which may produce injury if touched.

Combustion figures should be as follows:-

CO₂ = 7-8% condensing or 8-9% non-condensing (Dry flue gas).

CO = 0-50 ppm: however figure should not exceed 200 ppm under normal operating conditions.

The flame supervision device can now be checked by closing the gas cock on the inlet of the gas valve or by pressing/twisting the stop button on the gas control valve (Operation dependant on gas valve type fitted). After approximately 45 seconds the solenoid valve should be heard to click close. **Wait a further 3 minutes** and carry out pilot lighting procedure.

11.12 When the above is complete, the end user or their representative should be made aware of the lighting and operating instructions fitted to the inside of the boiler door. A practical demonstration should be given describing each functional step. This Installer's Guide and user's instructions should then be handed over and be kept in a safe place for easy reference.

12.0 FAULT FINDING (AUTOMATIC ONLY)

12.1 SAFETY FEATURES SUMMARY

Should the control thermostat fail, the temperature limiter will trip thus creating an immediate shutdown regardless of firing mode. An overheat neon on the controls fascia will indicate this condition has occurred. The door will have to be removed to permit access to the temperature limiter re-set pin. If, after pushing the pin in, the light on the fascia does not go out and the boiler does not light up, it could be that the boiler is still too hot, i.e. the control thermostat has not re-set. An investigation should be carried out to ascertain the reason for the overheating. An obvious reason would be too low a water flow rate through the boiler.

The flame is under constant supervision by the burner logic controller. This is accomplished by measuring the flame's ability to rectify an AC current. If the flame diminishes for whatever reason and the rectified current drops below the controllers minimum (Honeywell controller minimum detection current is 0.7 μ A D.C.), the controller will induce a non volatile lockout which will require a manual re-set (situated on the controls fascia) to re-start the control sequence. If the boiler continues to lockout, then an investigation must be made to ascertain the cause. See Fig.24/Page 43/44 for possible corrective scenarios.

A pressure switch is fitted to monitor the correct operation of the induced draught fan fitted to the

Warmwell HE. It ensures sufficient air is pulled through the boiler to facilitate correct combustion. The control circuit is configured to establish a light/dark check thereby ensuring the switch is open (no air) before starting the fan. Once started the circuit then checks that the switch has changed position (full air) thus allowing the boiler to light and continue firing.

12.2 FAULT FINDING PROCEDURES

General fault finding is shown in Fig.24/Page 43/44. If the boiler still cannot be operated satisfactorily after following the chart, consult your local office of Hamworthy Heating for assistance.

12.3 POSSIBLE CAUSES OF BOILER LOCKOUT (Automatic Ignition only)

- 1) Ignition failure due to no spark at electrode.
- 2) Ignition failure due to faulty gas valve.
- 3) Ignition failure due to broken igniter electrode or probe lead.
- 4) No gas supply.
- 5) Fan failure.
- 6) No ignition due to faulty controller.

12.4 FAULT FINDING (PERMANENT PILOT)

12.4.1 SAFETY FEATURES SUMMARY

Should the control thermostat fail, the temperature limiter will trip thus causing an immediate shutdown regardless of firing mode. If this occurs the temperature limiter situated in the controls housing will require re-setting by pushing the small pin in firmly. **Note!** Access to this pin is gained by removing door and unscrewing safety cover (if fitted). An investigation should be carried out to ascertain the reason for the overheating. An obvious reason would be to low a water flow rate through the boiler. **NOTE!** The pilot will not remain established if this is not carried out.

Volt free contacts are available for connection to B.E.M.System (optional extra). A pressure switch is fitted in the pilot gas line (**60 & 95 models only**) and in the event of pilot failure, a lockout neon illuminates on the controls fascia.

An air pressure switch is fitted to monitor the correct operation of the induced draught fan fitted to the Warmwell HE. It ensures sufficient air is pulled through the boiler to facilitate correct combustion. The control circuit is configured to establish a light/dark check thereby ensuring the switch is open (no air) before starting the fan. Once started the circuit then checks that the switch has changed position (full air) thus allowing the boiler to light and continue firing.

12.5 FAULT FINDING PROCEDURES

General fault finding is shown in Fig.23/Page 41/42. If the boiler still cannot be operated satisfactorily after following the chart, consult your local office of Hamworthy Heating for assistance.

12.6 POSSIBLE CAUSES OF BOILER LOCKOUT (Permanent ignition only)

- 1) Pilot failure due to faulty thermocouple.
- 2) Weak pilot due to blockage in pilot orifice.
- 3) No gas supply.
- 4) Temperature limiter operating due to high boiler temperature or faulty thermostat.
- 5) Faulty main gas valve.
- 6) Loose ECO lead from gas valve to thermostat. (60 & 95 only)
7. Fan failure.

13.0 SERVICING

13.1 Regular annual servicing is recommended to ensure trouble free operation. Although cleaning of flueways may not be necessary on a yearly basis, it is important that all controls and safety features are checked for correct operation. **NOTE!** Measuring flue gas CO₂ and gas temperatures will give an indication of the state of the boiler flueways and waterways. Results should be compared with previously measured values to establish possible loss of efficiency.

13.2 Before servicing the boiler, the following procedure must be carried out:- **WARNING: Isolate all electrical supplies and turn off the gas service cock to the boiler module being serviced.**

- 1) Remove the front casing door by using a screwdriver to rotate the ¼ turn latch.
- 2) Turn off the gas service cock, (fitted upstream of gas control valve).
- 3) Undo both screws on gas valve wiring plug, situated under controls assembly, and disconnect plug completely by pulling firmly downwards.
- 4a) **(Automatic Ignition).** Disconnect igniter and probe leads carefully. (Protective boots will require pulling back to reveal connectors.)
- 4b) **(Permanent Ignition).** Disconnect ECO connectors at gas valve if fitted and undo and disconnect pilot bundy tube from gas valve: disconnect piezo lead and thermocouple.
- 5) Slacken union below gas service cock and release. Slacken and remove nuts/washers holding gas valve and manifold assembly. Remove manifold assembly taking care not to damage gas solenoid or bundy tubing etc (if fitted).
- 6a) **(Automatic).** Carefully remove burner assembly by pulling burner front plate. Check condition of igniter assembly and probe for damage, clean as required. Check position of electrodes See Fig.16/Page 28.

Check burner bars and clean using a soft brush if required (if possible use compressed air to blow out the dust inside the bar). Damaged or cracked burner bars should be replaced. To replace an individual bar will require drilling out the rivets holding it on to the front plate, a replacement burner bar will be supplied with clinch nuts and screws to fix it onto the burner front plate.

6b) **(Permanent Ignition).** Undo and remove igniter assembly by removing screws from front tie bar (2 off). Carefully remove igniter assembly from under burner bar tie rod taking care not to twist or bend igniter electrode or bundy tubing. See Fig 16/Page 28

for position of items.

7) Carefully remove burner assembly by pulling burner front plate. Check condition of igniter assembly thermocouple and burner injectors for damage, clean as required. Check burner bars and clean using a soft brush if required (if possible use compressed air to blow out the dust inside the bar). Damaged or cracked burner bars should be replaced. To replace an individual bar will require drilling out the rivets holding it on to the front plate. A replacement burner bar will be supplied with clinch nuts and screws to fix it onto the burner front plate.

13.3 The boiler flueways can now be cleaned as follows:-

1) Carefully remove sloping front panel by pulling both edges around the centre position, this will give access to the transition duct cover. Remove nuts to gain access to the flueways. (Insulation jacket should be carefully prised open to reveal duct).

2) The boiler flueways are now exposed and can be brushed through diagonally in both directions to remove deposits from the cast iron finned surfaces. Check secondary heat exchanger surfaces and wash if required. Re-assemble the boiler in the reverse order to that shown above. Ensure a new seal is fitted to the cover to ensure a gas tight seal.

Before replacing the burner bar assembly, lift out both halves of the radiant reflector and brush off any dust and fallen deposits accumulated on it. Also clean the area under the reflector before re-placing it in its correct location. Ensure cutout is positioned on left side (Permanent Ignition model only). Re-assemble the burner bar assembly, ensuring correct location on the rear support bracket.

Check all gas connections are tightened securely before opening the gas service cock. Switch on the electricity supply and re-light the boiler following the correct procedure on the inside of the door.

Take gas pressure readings and exhaust gas readings and compare with Fig.3/Page 7, adjust as required. Ensure no gas leaks are evident from the gas connections, see Fig.5/Page 10 for procedure.

Check thermostat settings and adjust if required. Re-fit door and tidy floor around boiler as necessary.

14.0 REPLACEMENT OF FAILED COMPONENTS

There are a number of components listed below which can be replaced simply and quickly by following the given procedure. In each case the operation of each replaced component must be checked by carrying out the appropriate part of the commissioning procedure. See Section 11.0: **COMMISSIONING & TESTING. NOTE: Isolate electrical supply to the boiler and turn off the gas supply before removing controls cover and commencing any servicing or component exchange procedure.**

14.1 IGNITER ASSEMBLY (AUTOMATIC IGNITION)

Reference to Fig.16/Page 28 shows position of igniter assembly. To remove assembly the igniter

lead must first be disconnected from the electrode, (Protective boot to be pulled along cable to reveal connector). Fig.16/Page 28 shows diagram of igniter assembly and relevant components and part numbers. Renew components as required and generally remove any loose sooty deposits and clean as required. Ensure positions of components are as recommended in Fig.16/Page 28. (Ensure protective boot is replaced over electrode.)

14.2 PILOT BURNER ASSEMBLY (PERMANENT IGNITION)

Reference to Fig.16/Page 28 shows position of pilot burner. To remove pilot assembly the bundy tube, thermocouple and piezo spark cable must first be disconnected from the gas valve. Fig.16/Page 28 shows diagram of pilot assembly and relevant components and part numbers. Renew components as required and generally remove any loose sooty deposits and clean as required. Ensure positions of components are as recommended in Fig 16/Page 28.

14.3 CONTROL THERMOSTAT RENEWAL: PART NO. 339009345 OR 533901178

Alternative thermostat manufacturers may be used in the Warmwell HE boiler controls assembly. However, the fitting and wire spade connections are physically identical. The terminal identification may well be different from that shown on the wiring diagram inside the fascia. Please refer to the thermostat to ensure correct electrical connections are made and correct operation is obtained.

To replace the thermostat the following procedure must be followed. **NOTE!** Record existing temperature setting of thermostat for reference before removal. Remove holding screws underneath front cover and lift boiler top panel to reveal thermostat pocket. Carefully remove thermostat phials. Drop down fascia to reveal controls section. Remove the 'push on' spade connectors from the thermostat body noting position of coloured cables. Pull off the control knob and remove bezel. (**Note!** This may be retained by the two M3 screws holding the thermostat to its bracket). Check whether screws are of different type/length for re-assembly purposes before removing them. The thermostat body can now be removed by gently feeding capillary through the controls bulkhead. Fit the new thermostat and ensure the capillary is correctly located within the boiler pocket. Do not force the bulb into the pocket by placing undue stress on the capillary. Close fascia and re-fit top panel correctly.

Run the boiler and turn the thermostat up and down to check for correct operation. Set thermostat to previously noted setting.

14.4 TEMPERATURE LIMITER (LIMIT STAT) RENEWAL: PART NO. 533901168/533901180 (PERMANENT PILOT) OR PART NO. 533901179/339011044 (AUTOMATIC AND PILOTSTAT-PERMANENT PILOT)

The temperature limiter renewal procedure follows that of the control thermostat with some minor differences. These are as below:-

Remove the 'push on' spade connections from the temperature limiter body noting position of coloured cables. Remove plastic cover (if fitted) and unscrew holding nut to detach temperature limiter from housing. Gently feed the capillary back through the controls bulkhead. Set temperature limiter to 100°C. Re-assemble temperature limiter into controls housing ensuring correct cable notation. Refer to thermostat diagram if terminal identification differs from those given in Fig.19,20,21 & 22/Page 37,38,39 & 40 (Boiler schematic wiring diagrams).

14.5 MAIN GAS VALVE (AUTOMATIC)

NOTE! Some gas valve components can be replaced without completely removing the whole assembly from the boiler. However, Hamworthy Heating strongly recommend that a new gas valve assembly is fitted to ensure safe, reliable operation of the boiler. Please refer to Hamworthy Heating Technical Department before attempting to remove components from the gas valve. Various types and manufacturers of gas valves are used. Refer to Fig.13/Page 24 for particular valve(s) fitted.

1) Ensure power and gas supplies are isolated.

2) Remove the gas valve wiring plug from the socket in the controls housing by un-doing both screws and pulling firmly downwards. Undo the union connection and 8 mm nuts holding the gas valve/manifold assembly to front plate, this will allow the whole assembly to be removed from the boiler.

3) Remove the gas valve by unscrewing cap head screws holding valve to pipework. **NOTE!** The position of the relevant electrical cables should be noted, especially on the 140 boiler. When replacing the gas valve, it is advisable to renew the 'O' ring seals sealing both ends. See recommended spares section for Part Nos. Note that the 60 and 95 'O' ring is different to the 140 'O' ring. Do not over tighten cap head screws in gas valve body. Ensure electrical plugs are firmly and correctly located and holding screws are tightened.

4) Replace assembly ensuring correct orientation of the gas valve. Ensure that the gas flow is in the same direction as the arrow on the bottom of the valve. Refit all external components and replace plug into controls housing socket, re-fit and tighten screws holding plug to housing. Switch on gas and power supply and check for integrity of all joints using a proprietary leak detector. Ensure gas valve(s) operation is correct and safe before continuing. Refer to Fig.5/Page 10 if necessary for valve integrity check procedure.

5) Re-light the boiler using instructions on the inside of the door. Check and adjust, the low fire/start gas and high fire gas pressures, refer to Fig.3/Page 7 for correct settings. If necessary, refer to Section 11.4 **COMMISSIONING THE BOILER**, for correct procedures.

14.6 MAIN GAS VALVE (PERMANENT PILOT)

NOTE! Some gas valve components can be replaced without completely removing the whole assembly from the boiler. However, Hamworthy Heating strongly recommend that a new gas valve

assembly is fitted to ensure safe, reliable operation of the boiler. Please refer to Hamworthy Heating Technical Department before attempting to remove components from the gas valve. Various types and manufacturers of gas valves are used. Refer to Fig 17/Page 30 for particular valve fitted.

1) Ensure power and gas supplies are isolated.
2) To remove the gas valve first undo and remove the pilot bundy tube, thermocouple, ECO connections (if fitted) and the piezo spark generator bracket (if fitted).

3) Remove the gas valve wiring plug from the socket in the controls housing by un-doing both screws and pulling firmly downwards. Undo the union connection and 8 mm nuts holding the gas valve/manifold assembly to front plate, this will allow the whole assembly to be removed from the boiler.

4) Remove the gas valve by unscrewing cap head screws or screwed fitting holding valve to pipework. **NOTE!** The position of the relevant electrical cables should be noted.

When replacing the gas valve, it is advisable to renew the 'O' ring seals (if fitted). See recommended spares section for Part No.s. **NOTE!** That the 60 and 95 models gas valve 'O' ring is different to the 140 model gas valve 'O' ring. Do not over tighten cap head screws in gas valve body. Ensure electrical plugs are firmly and correctly located and holding screws are tightened.

5) Replace assembly ensuring correct orientation of the gas valve. Ensure that the gas flow is in the same direction as the arrow on the valve. Refit all external components and replace plug into controls housing socket, re-fit and tighten screws holding plug to housing. Switch on gas and power supply and check for integrity of all joints using a proprietary leak detector.

Ensure gas valve's operation is correct and safe before continuing. Refer to Fig.5/Page 10 if necessary, for valve integrity check procedure.

6) Re-light the boiler using instructions on the inside of the door. Check and adjust, the manifold gas pressure, refer to Fig 3/Page 7 for correct setting relating to the boiler size installed.

If necessary, refer to section **11.4:COMMISSIONING THE BOILER**, for correct procedures.

14.7 FAN ASSEMBLY

Ensure power supply is isolated. Access to the rear of the boiler is required to service this item.

NOTE! The plug and socket assembly requires a 'tool' to disengage the locking mechanism. A screwdriver should be inserted into the slot in the plug and socket assembly. The plug can then be pulled away from the socket.

Undo the 4 nuts holding the motor assembly to the fan housing and remove complete motor and impeller unit.

Due to the aggressive media being handled, it is recommended that the complete fan motor and impeller assembly is replaced if a motor has failed.

If required clean fan impeller taking care not to bend or distort assembly.

Re-assemble unit in reverse order of dis-assembly. **NOTE!** All models have a capacitor fitted. Before replacing motor due to possible failure, ensure the capacitor is functioning correctly.

Ensure all screws are tightened and re-fit plug/socket assembly.

Periodically check the fan volute which is inside the plenum chamber. This will require removal of the stainless steel plenum chamber at the rear of the boiler. Ensure flue is supported before removal.

The fan volute is fitted internally and fixed to the plenum by the pressure tapping connection assembly. **NOTE!** Connect pressure sensing tubes to their relevant positions to achieve correct operation of the pressure switch(es). See Fig. 12/Page 22 for tube/switch assembly layout.

Re-fit the fan assembly ensuring the gasket between the fan fixing plate and plenum is replaced if damaged. Spin the fan to ensure the impeller is free. Ensure the fan plug and socket assembly is securely fitted and locked together. Re-light the boiler and check for correct operation of pressure switch(es). See Fig.3/Page 7 for correct settings.

15.0 RECOMMENDED SPARES

Please Note! To ensure the correct spare parts are despatched by our spares department, it is imperative that the complete Boiler/Control Panel Serial Numbers are given. The Boiler Serial Number is located on the gas manifold inside the door. The Electrical Serial Number is located inside the Control panel on the maximum power rating label. These numbers **MUST** be quoted when ordering spare parts.

SPARES ITEM	PART NO.
ELECTRICAL ITEMS	
2 Amperes Control Fuse	747225834
Green Neon	533901031
Amber Neon	533901030
Red Neon	533901029
Reset-button/Gas Valve Pushbutton	533901132
Hours Run Meter	533901067
Ignition Sequence Controller	533901169
Time delay relay	533901035
230 Volt Single Pole Relay	533901204
230 Volt Double Pole Relay	533901206
230 Volt Four Pole Relay	747247523
Fan speed controller	533901231
'Lo' speed transformer	533901234
Fan assembly (Complete)	533901229
MECHANICAL ITEMS	
Single Burner Bar	533301003
Heat Exchanger Nipple	330502033
Injector Copper Washer	339008347
Pilot burner injector (Natural Gas only)	331101843
Gas Valve 'O' Ring Joint (60-95 model only)	742111245
Gas Valve 'O' Ring Joint (140 model only)	742122069
Spark Electrode (Automatic Only)	533805005
Probe Electrode (Automatic Only)	533805004
Control Thermostat	533901178(lmit)
"	
	339009345(L&G)
Temperature Limiter (Automatic and Pilot-stat Only)	533901179(lmit)
"	
	339011044(L&G)
Piezo Generator and Lead	333805342
Temperature Limiter 60 & 95 models (Permanent Pilot Only)	533901180(lmit)
"	
	533901168(L&G)

Fuse holder 747224779

For replacement gas valves refer to Hamworthy Heating spares department.

For service or spares please contact:- **Hamworthy Heating Ltd.**
Fleets Corner
Poole
Dorset BH17 0HH

Phone No. 01202 665566
Fax. No. 01202 665111

Figure No 18

GAS FLOWS IN PIPES WARMWELL HE BOILERS

Total Gas Input M ³ /Hr	Maximum length of gas pipe (Metres)						
	¾" dia.	1" dia.	1½" dia.	2" dia.	2½" dia.	3" dia.	4" dia.
4.73	10	42	-	-	-	-	-
5.92	-	25	180	820	-	-	-
7.10	-	16	120	540	-	-	-
8.27	-	11	85	380	-	-	-
9.44	-	-	62	280	900	-	-
11.19	-	-	42	185	580	-	-
12.36	-	-	33	145	470	-	-
14.1	-	-	25	110	345	-	-
18.88	-	-	12	56	180	-	-
22.38	-	-	-	38	120	750	-
24.72	-	-	-	30	96	600	-
28.20	-	-	-	22	72	440	-
33.57	-	-	-	15	47	290	-
37.08	-	-	-	11	37	235	-
42.30	-	-	-	-	27	170	810
44.76	-	-	-	-	24	150	730
49.44	-	-	-	-	19	115	570
56.40	-	-	-	-	14	86	430
61.80	-	-	-	-	11	71	340
70.50	-	-	-	-	-	51	245
74.16	-	-	-	-	-	46	220
84.60	-	-	-	-	-	34	165

The above table expresses pipe lengths from gas meter to appliance which will produce approx. 1 mbar pressure loss. This table must be used in conjunction with losses of various fittings fitted in the gas line shown below.

Fitting Type	¾" dia.	1" dia.	1½" dia.	2" dia.	2½" dia.	3" dia.	4" dia.
Per elbow	0.5 m	0.5 m	1.0 m	1.5 m	2.0 m	2.5 m	3.5 m
Per Tee	0.5 m	0.5 m	1.0 m	1.5 m	2.0 m	2.5 m	3.5 m
Per 90° Bend	0.3 m	0.3 m	0.3 m	0.5 m	0.5 m	1.0 m	1.5 m

For example:- 1 Warmwell HE 140 & 1 Purewell 120 Kw Boiler being fed by 2½" pipe with 6 elbows between gas meter and boiler header can have a maximum length of 72 m - (6 x 2 m) = 60 metres run to achieve a 1 mbar loss. **Note! Information above is based on IM/16.**



HAMWORTHY

heating products

Figure No 19 Permanent Pilot Wiring Schematic (Pilot-stat operation).

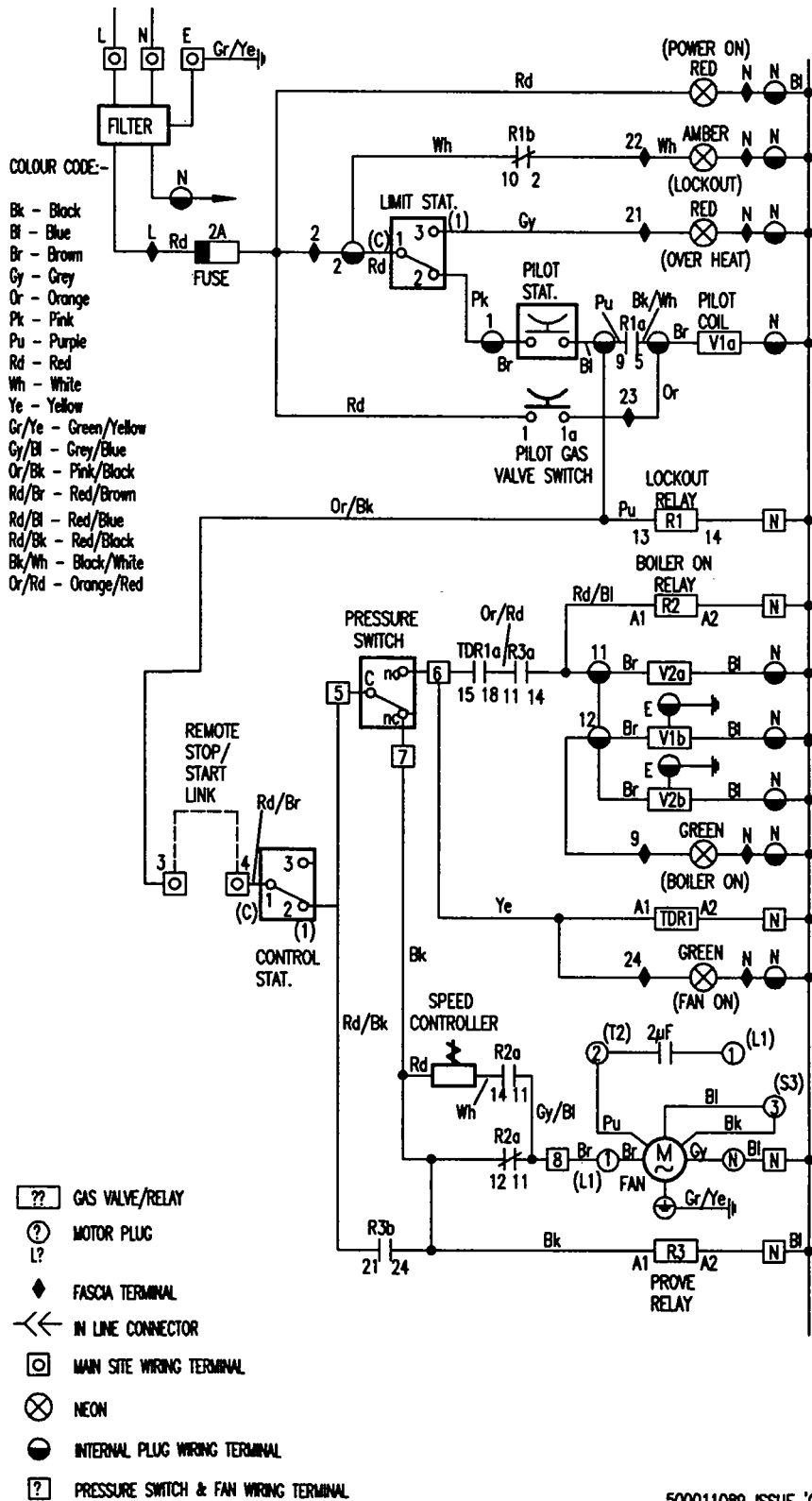

500011089 ISSUE 'C'



HAMWORTHY

heating products

Figure No 20 Permanent Pilot Wiring Schematic (ECO operation).

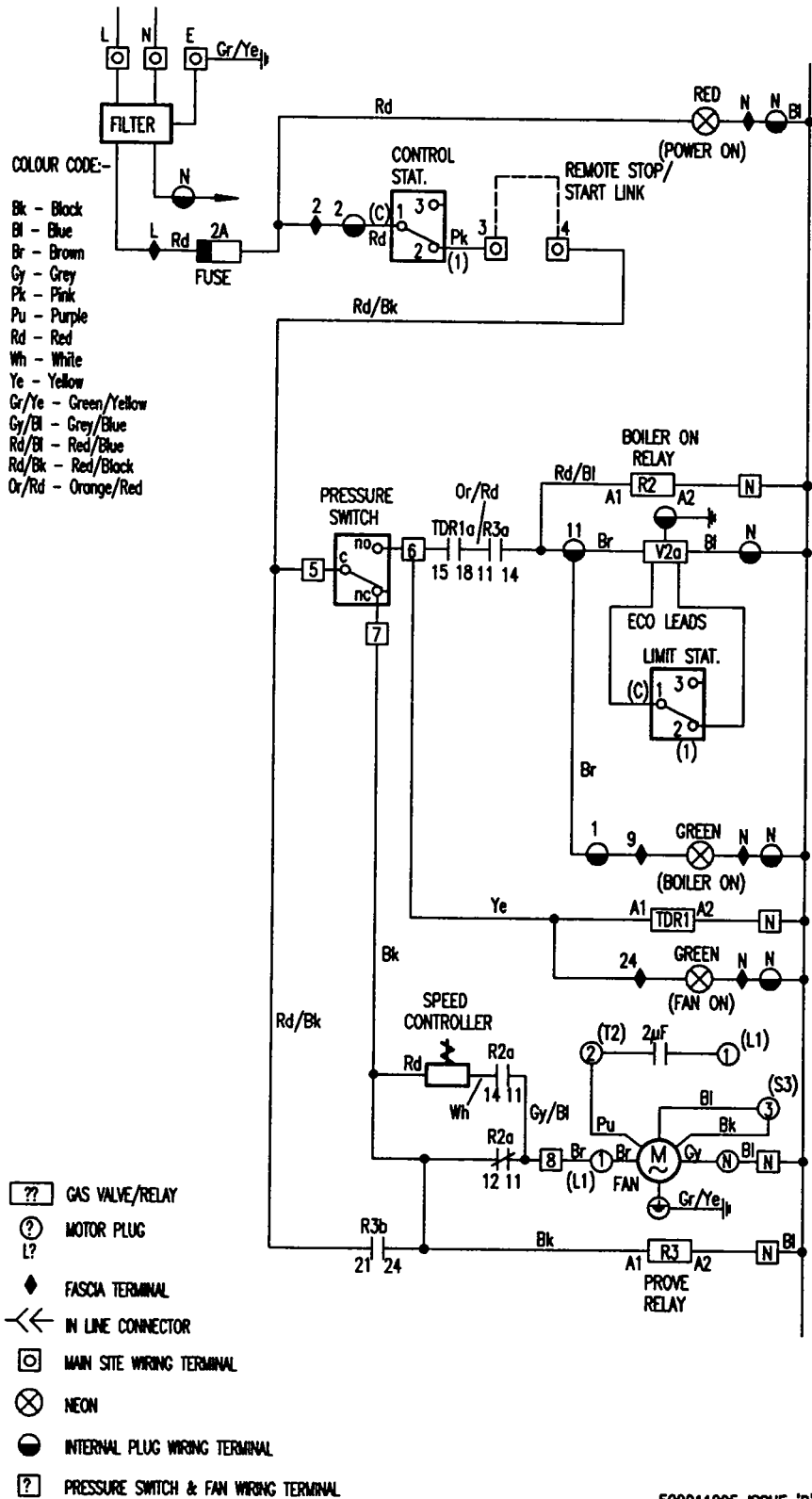

500011095 ISSUE 'D'

Figure No 21 Automatic Wiring Schematic.



HAMWORTHY
heating products

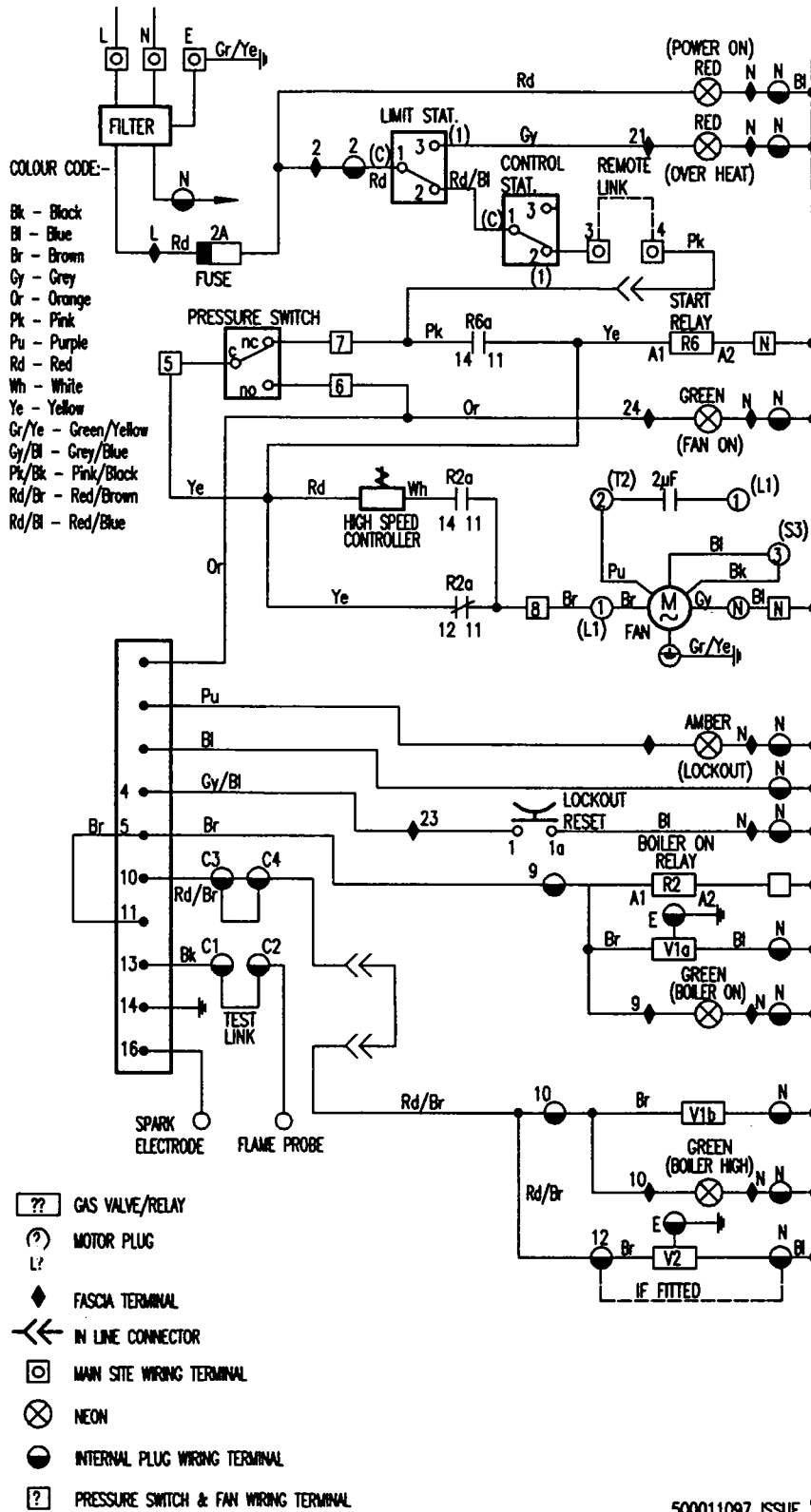
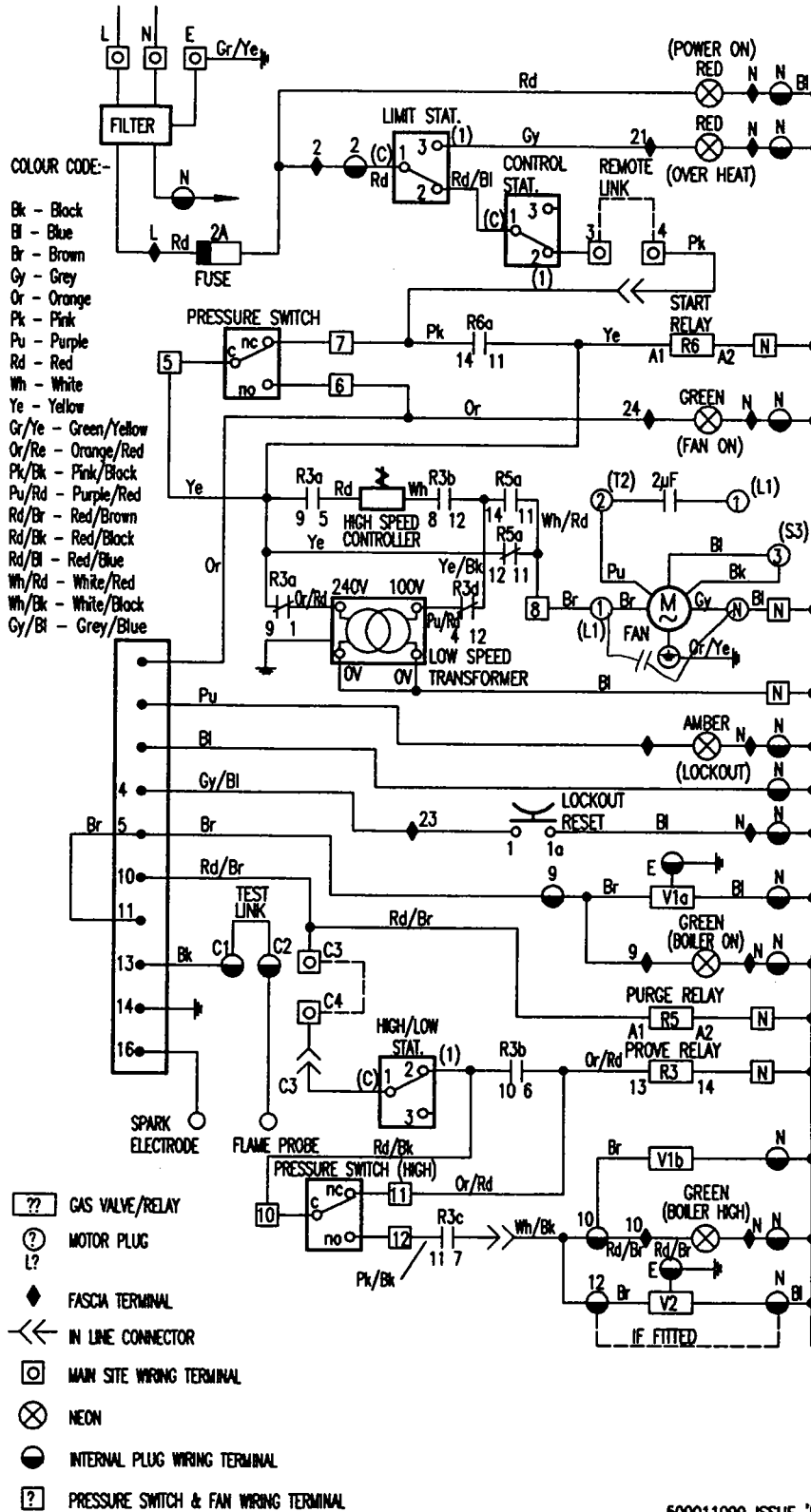

Figure No 22 Automatic Hi/Lo Wiring Schematic.



HAMWORTHY
heating products



500011099 ISSUE 'F'



Figure No 23a

Fault Finding Procedures (Permanent Pilot Only)

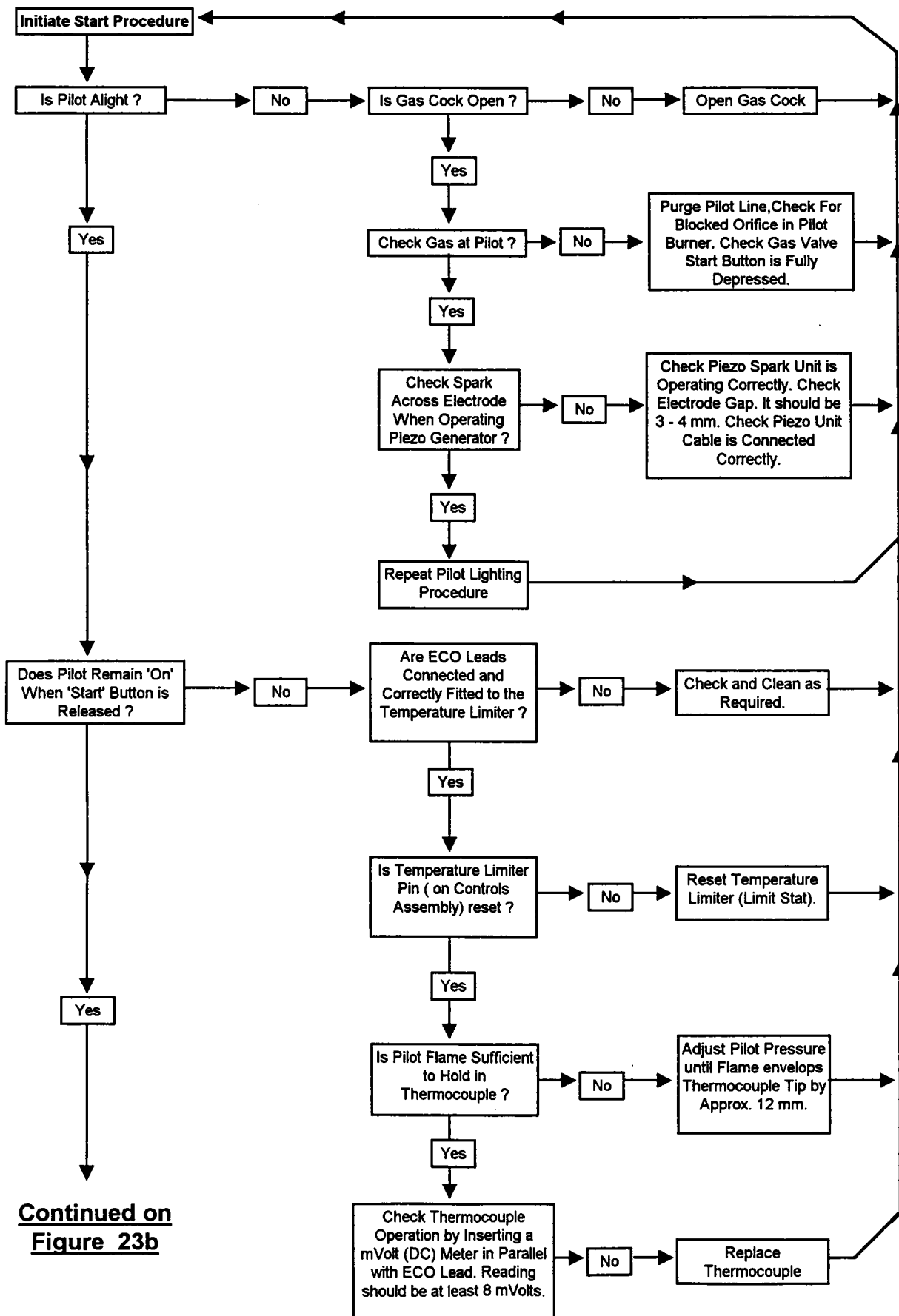

Continued on Figure 23b



Figure No 23b

Fault Finding Procedures (Permanent Pilot Only)

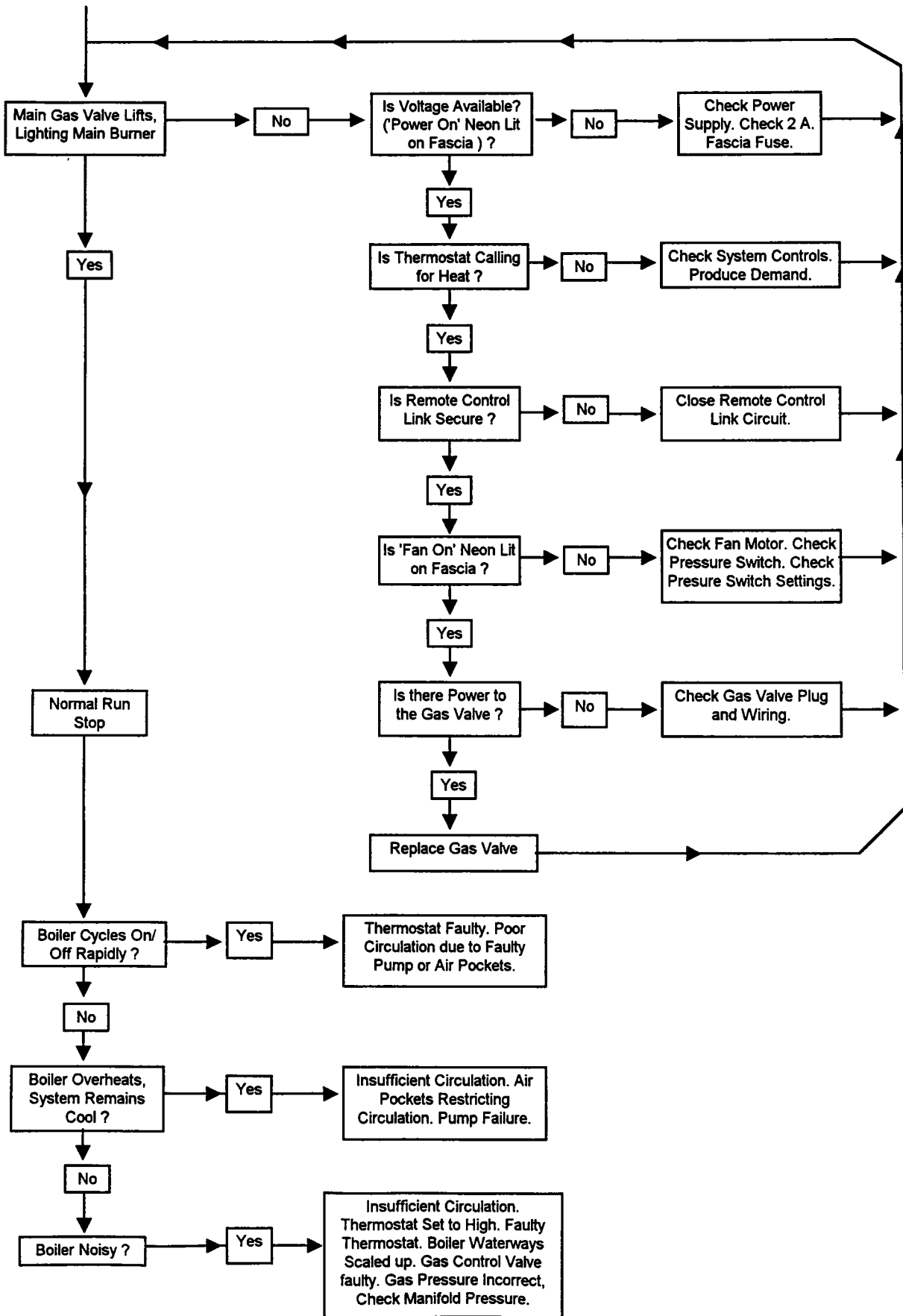
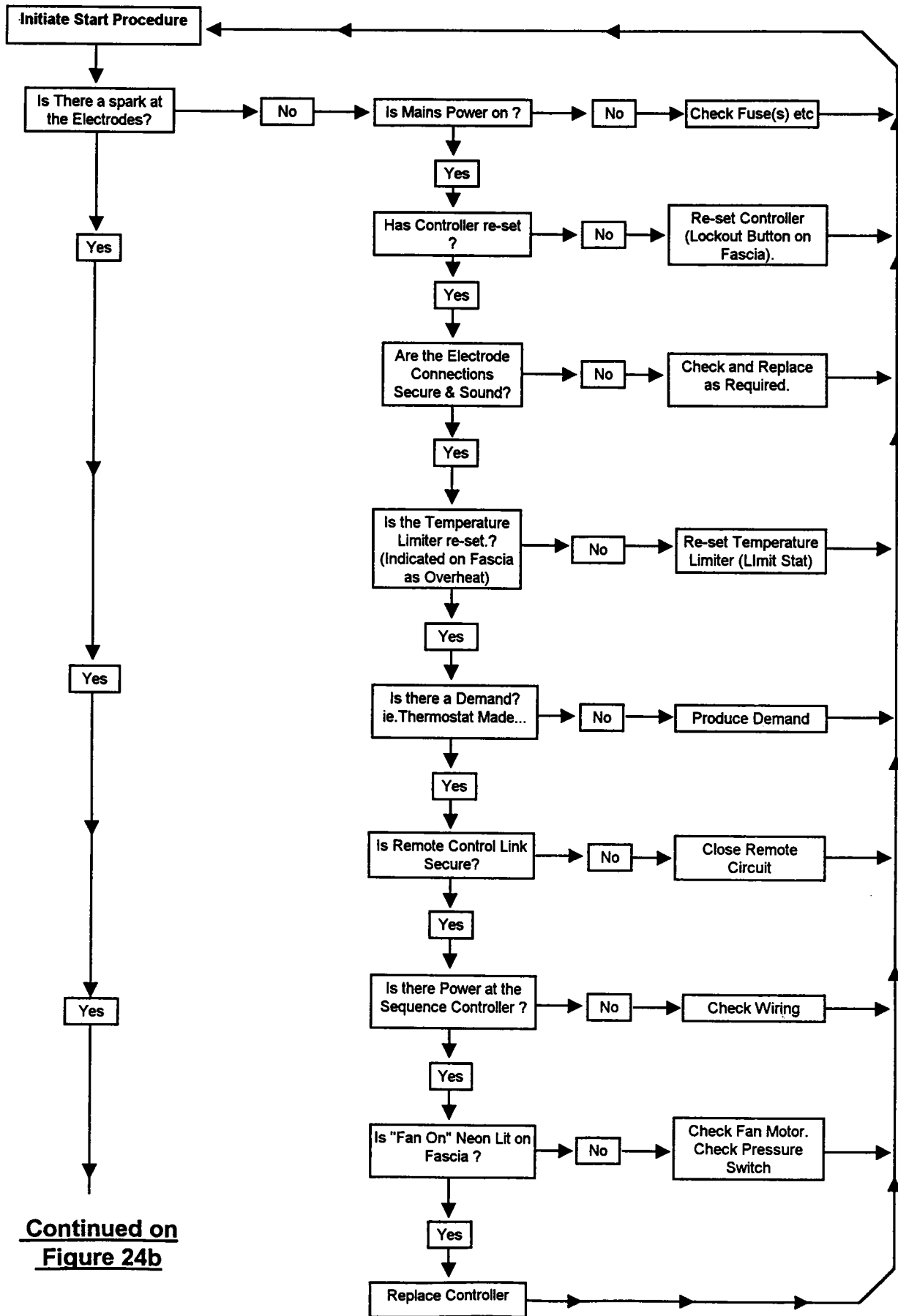



Figure No 24a

Fault Finding Procedures (Automatic Only)



Continued on Figure 24b



Figure No 24b

Fault Finding Procedures (Automatic Only)

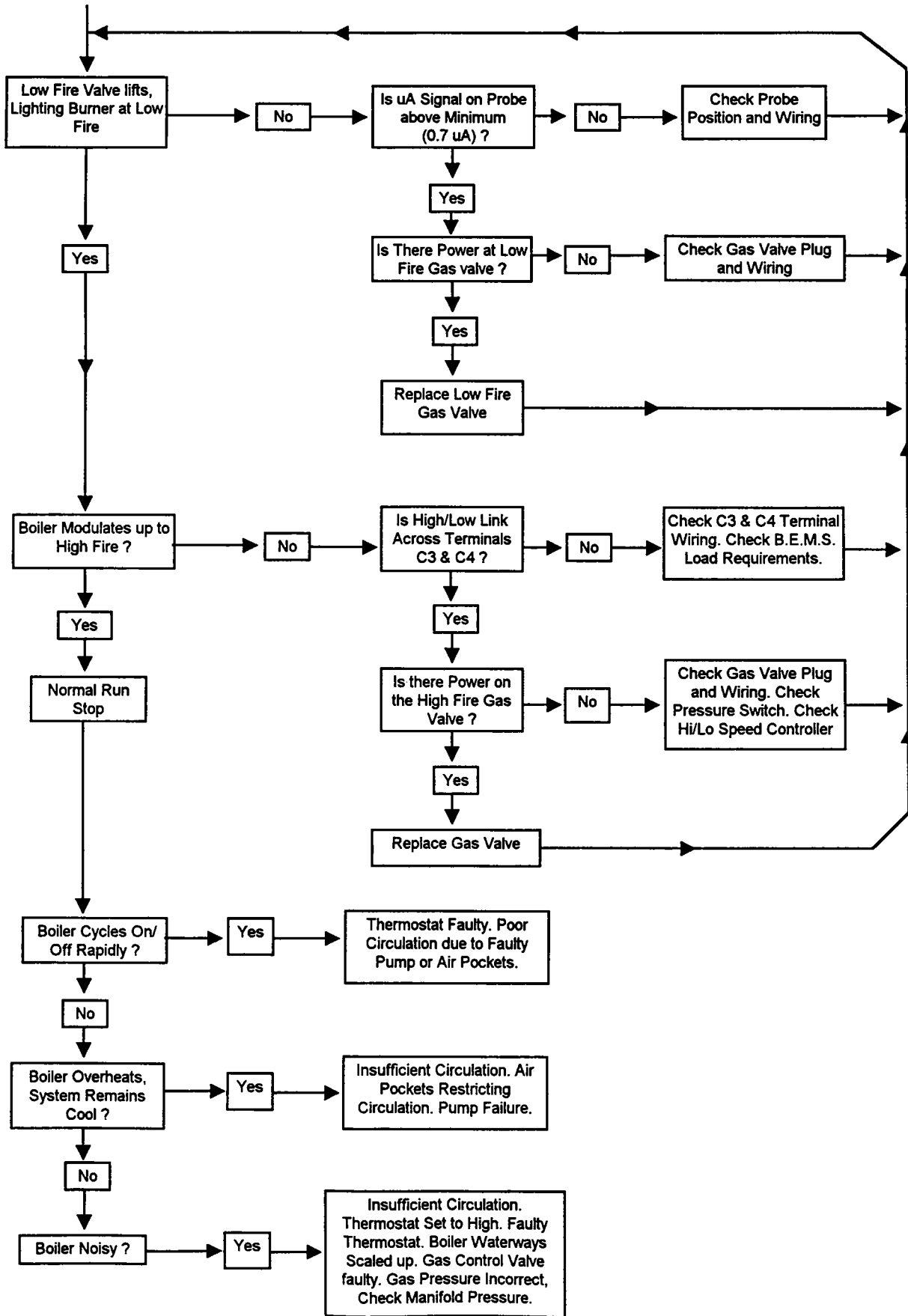

Customer Services

CUSTOMER SERVICES

APPLICATION

To supplement the detailed Technical Information Booklets, technical advice on the application and use of the Hamworthy Heating Product Range is available from Poole and through the regional Sales offices and Accredited Agents.

COMMISSIONING

A commissioning service is offered for all the Hamworthy Heating Products. Commissioning by the manufacturer ensures the most efficient performance is achieved safely and ensures correct operation.

Hamworthy commissioning reports are detailed and definitive. Such information reports on the original status of the plant are essential for future routine maintenance and fault finding situations.

ROUTINE SERVICE

Hamworthy offer routine service contracts for all products. Planned maintenance of equipment by routine servicing reduces operational costs considerably below that associated with repair or breakdown approach. Regular servicing by Hamworthy trained staff ensures that all equipment is operating to optimum efficiency.

The frequency of visits to maintain installations up

to required level is variable depending upon the equipment type and usage.

BREAKDOWN SERVICE, REPAIR, REPLACEMENT

Even when the commissioning and routine servicing has been carried out to the highest standard there are always occasions when the unexpected breakdowns occurs. Hamworthy provide a rapid response breakdown, repair or replacement service through its regional offices and Accredited Agents located throughout the UK.

SPARE PARTS

A comprehensive spare parts service is operated from our head office at Poole providing delivery, even for out of date items in most cases. In some instances spares may be available from regional offices and Accredited Agents.

Delivery of parts and components is normally from stock within 7 days. However, a 24 hour service is available for breakdowns and emergencies for the additional cost of the courier.

For your spares enquiries and orders please contact Carol Miller on 01202 665566.

To help Carol and her staff help you, please give as much detail as possible of the product type, serial number or any other identifying marks or codes.

**HEAD OFFICE (DEPOT & WORKS)
HAMWORTHY HEATING LIMITED
FLEETS CORNER,
POOLE, DORSET BH17 0HH
TEL: 01202 665566
FAX: 01202 665111**

OFFICES:

**MIDLANDS
HAMWORTHY HEATING LIMITED
Shady Lane,
Great Barr,
Birmingham B44 9EX
Tel: 0121 360 7000
Fax: 0121 325 0890**

**ACCREDITED AGENTS:
BERKS, BUCKS, OXON,
SURREY & WEST LONDON
FOWLER COMBUSTION CO. LIMITED
18 Oxford Road,
Wokingham,
Berks RG11 2XY
Tel: 01734 784350 Fax: 01734 771497**

**SOUTH (CENTRAL)
DRIVER ENGINEERING LIMITED
778 Wimborne Road,
Moordown,
Bournemouth BH9 2DX
Tel: 01202 525140 Fax: 01202 536442**

**NORTH WEST (PART)
GILLIES MODULAR SERVICES
210-218 New Chester Road,
Birkenhead,
Merseyside L41 9BG
Tel: 0151 666 1030**

**NORTH EAST (PART)
ALLISON HEATING PRODUCTS
17 Beach Road,
South Shields,
Tyne & Wear NE33 2QH,
Tel: 0191 455 7898 Fax: 0191 455 7899**

**SCOTLAND
McDOWALL MODULAR SERVICES
97a Hawthorn Street,
Glasgow G22 6JD
Tel: 0141 336 8795 Fax: 0141 336 8954**

**NORTHERN IRELAND
McCAIG COLLIM LIMITED
94 Dargan Crescent,
Duncrue Industrial Estate,
Belfast BT3 9JP
Tel: 01232 777788**

HAMWORTHY
heating products

Offices and Agents throughout the world

Hamworthy reserve the right to make changes and improvements which may necessitate alteration to the specification without prior notice.