

# **Cranborne THR 10-50c Wall Hung Gas Fired Condensing Boiler Room Sealed or Open Flue**

## **INSTALLATION, COMMISSIONING AND SERVICING INSTRUCTIONS**

**IMPORTANT NOTE: THESE INSTRUCTIONS MUST BE READ AND UNDERSTOOD BEFORE INSTALLING, COMMISSIONING, OPERATING OR SERVICING THIS APPLIANCE.**

**THE CRANBORNE THR 5-25c BOILER IS INTENDED FOR USE AS A DOMESTIC / LIGHT COMMERCIAL APPLIANCE FOR HEATING AND DOMESTIC HOT WATER INSTALLATIONS.**

**THIS BOILER IS FOR USE ON GROUP H NATURAL GAS (2<sup>ND</sup> FAMILY) I<sub>2H</sub>. PLEASE ENSURE RELEVANT INFORMATION REQUIRED WITHIN DOCUMENT IS FOUND RELATING TO SPECIFIC GAS TO BE FIRED BEFORE FIRING BOILER.**

**THIS BOILER COMPLIES WITH ALL RELEVANT EUROPEAN DIRECTIVES  
EC IDENTIFICATION No. CE-0085AR0323**

**PUBLICATION NO. 500001107  
ISSUE 'A'  
MAY 2001**

## CONTENTS

	PAGE
Front Cover	i
Index	ii
<b>1.0 GENERAL PRESENTATION</b>	<b>1</b>
1.1 Description	
1.2 Technical specification	
1.3 Delivery	
1.4 Options	
<b>2.0 OPERATION</b>	<b>3</b>
2.1 Principle	
2.2 Control options	
2.3 Functions common to the control options	
2.4 Heat exchanger/condenser	
2.5 Gas valve	
<b>3.0 DIGITAL DISPLAY</b>	<b>12</b>
3.1 Normal operation	
3.2 List of display codes	
3.3 List of alarm codes	
<b>4.0 INSTALLATION</b>	<b>13</b>
4.1 Related documents	
4.2 Location of boiler	
4.3 Air supply	
4.4 Water circulation system	
4.5 Mounting and clearances	
4.6 Spacer back plate	
4.7 Ancillary connections	
4.8 Water flow through heat exchanger	
4.9 Flue systems	
4.10 Gas supply	
4.11 Electrical supply	
<b>5.0 COMMISSIONING</b>	<b>23</b>
5.1 General	
5.2 Procedure for initial lighting	
<b>6.0 MAINTENANCE</b>	<b>26</b>
6.1 General	
6.2 Annual service	
<b>7.0 DOMESTIC HOT WATER TANKS</b>	<b>27</b>
7.1 Water connections	
7.2 Electrical connections	
7.3 Operating principle	

**FIGURES:**

	PAGE
Fig 1 Boiler dimensions	2
Fig 2 Boiler components	3
Fig 3 Control panel	4
Fig 4 Operating diagram	5
Fig 5 Air/gas servo system	6
Fig 6 Basic boiler control scheme	6
Fig 7 Boiler with outside sensor	7
Fig 8 Compensation chart	7
Fig 9 Boiler with inside and outside sensors	8
Fig 10 Efficiency chart	10
Fig 11 Gas valve	11
Fig 12 Mounting and clearances	14
Fig 13 Spacer back plate mounting	15
Fig 14 Open flue system	17
Fig 15 Room sealed flue systems	18
Fig 16 Vertical room sealed flue system	19
Fig 17 Standard horizontal room sealed flue system	20
Fig 18 Extended horizontal room sealed flue system	21
Fig 19 Horizontal room sealed flue system terminal positions	22
Fig 20 Wiring diagram	24
Fig 21 Combustion system	26
Fig 22 Ignition setting dimensions	26
Fig 23 Water connections to hot water tank	27
Fig 24 Electrical connections to hot water tank	27

**TABLES:**

Table 1 Technical specification	1
Table 2 Minimum air vent free areas	14
Table 3 Boiler settings/readings	25

THIS PAGE BLANK

## 1.0 GENERAL PRESENTATION

### 1.1 Description

The Cranborne THR 10-50c is a wall mounted gas fired condensing boiler suitable only for sealed hot water systems and operating with either an open flue system (B<sub>23</sub>) or a room sealed flue system (C<sub>13</sub>, C<sub>33</sub>). In the room sealed mode of operation, the flue outlet/air intake system must be designed to and comprise the details and items shown within this installers guide.

The boiler incorporates linear power modulation and a pre-mix burner with an air-gas servo-control system, meeting the requirements of prEN483 (12-97), EN437 (02-94) and prEN677 (03-96).

The power output is controlled by an integrated electronic regulator according to the heating system's or domestic hot water requirements. The gas/air ratio is controlled by a servo-valve system which maintains the correct mixture across the full operating range.

A styled casing contains the following components:-

- A high performance condensing heat exchanger made from finned tubes.
- A variable speed fan controlled by the regulator.
- A premix burner with a heat resistant stainless steel flame ring.
- A 24 Volt gas valve unit with dual air pressure valve control.
- A heating circuit safety valve set at 3 bar.
- A condensate siphon trap.
- An 'Overheat' safety cut-out with manual reset set at 100°C.
- A water pressure sensor.

- A 'Flue Gas Overheat' safety cut-out with manual reset set at 85°C.
- A circulating pump.
- A micro-processor based control panel providing boiler regulation, ensuring smooth operation and including the following:-
  - flame ionisation monitoring
  - heating system temperature adjustment
  - domestic hot water temperature adjustment
  - pressure display
  - operating sequence display
  - fault display
  - on/off switch

### 1.2 Technical Specification

For technical data, see Table 1

For dimension data, see Figure 1

Connection sizes: -

Gas Inlet	R 1	(Item 2)
Heating Flow	R 1	(Item 3)
Heating Return	R 1	(Item 4)
Primary HWS Return (if fitted)	R 1	(item 7)
Condensate Drain	32mm PVC	(Item 5)
Pressure Relief Valve Drain	27mm	(Item 6)
Flue Diameter:-		
Room Sealed C13 (horizontal)	80mm	(Item 1)
Room Sealed C33 (vertical)	80mm	(Item 1)
Open Flue B23	139mm	(Item 1)

(Item Numbers refer to Figure 1)

**Table 1 - Technical Specification**

MODEL		THR 10-50c
EC Approval		CE0085AR0323
Category		II <sub>2H3P</sub>
Heat Output (min/max)	30/50°C (B <sub>23</sub> ) 30/50°C (C <sub>13</sub> /C <sub>33</sub> ) 60/80°C (B <sub>23</sub> )	kW 10.6 / 50.5 kW 10.6 / 47.8 kW 9.5 / 47.0
Heat Input (min/max)		kW 10.0 / 50.0
Efficiency on NCV (min/max) at 30/50°C		% 106.0 / 101.0
	at 60/80°C	% 95.0 / 94.0
Efficiency on GCV (min/max) at 30/50°C		% 95.4 / 91.0
Type of Gas		Natural Gas H or Propane
Combustion Products Temperature (max)	°C	80
Combustion Products Rate (min/max)	kg/h	18.0 / 90.0
Allowable Back Pressure on Flue (max) (B <sub>23</sub> )	Pa	0
NO <sub>x</sub> Emission	mg/kWh	<60
CO Emission	mg/kWh	<50
Heating Water Pressure (min/max)	Bar	1.0/3.0
Heating Water Temperature (max)	°C	75
Boiler Water Capacity	litres	3.8
Weight - without water	kg	70.0
- with water	kg	73.8
Electrical Supply/Frequency		230V (+10%, - 15%)/50Hz
Electrical Power Consumption	W	245
IP Rating - Room Sealed (C <sub>13</sub> /C <sub>33</sub> )		IP44
- Open Flue (B <sub>23</sub> )		IP24
Wall Losses at 70°C	W	190

### 1.3 Delivery

The boiler is delivered complete within a palletised cardboard carton that also contains the wall plate. A 20l container of 'Inibal' water treatment and an aluminium 80/139mm flue adapter (for use with open flue systems) are packed within the boiler casing. Care should be exercised when first removing the boiler front casing. Locate the 4 toggle clamps (2 on top and 2 underneath the boiler) and remove the 4 cap head screws which act as locks. Release the clamps and carefully pull the casing front forward. Allow it to rest on the 2 extended supports at the top internal corners of the boiler and disconnect the earth cable before removing completely. The room sealed flue parts and

the available options are delivered in separate cardboard cartons.

### 1.4 Options

The boiler can also be supplied with the following options: -

- a) A spacer back plate which fits between the boiler and the wall to provide space to run pipework behind the boiler, refer to section 4.6.
- b) An outside sensor, refer to section 2.2.2.
- c) A room sensor/programmer to be used in conjunction with the outside sensor, refer to section 2.2.3.
- d) A hot water kit that is required if DHWS is to be generated from the boiler, refer to section 7.0.

Fig. 1

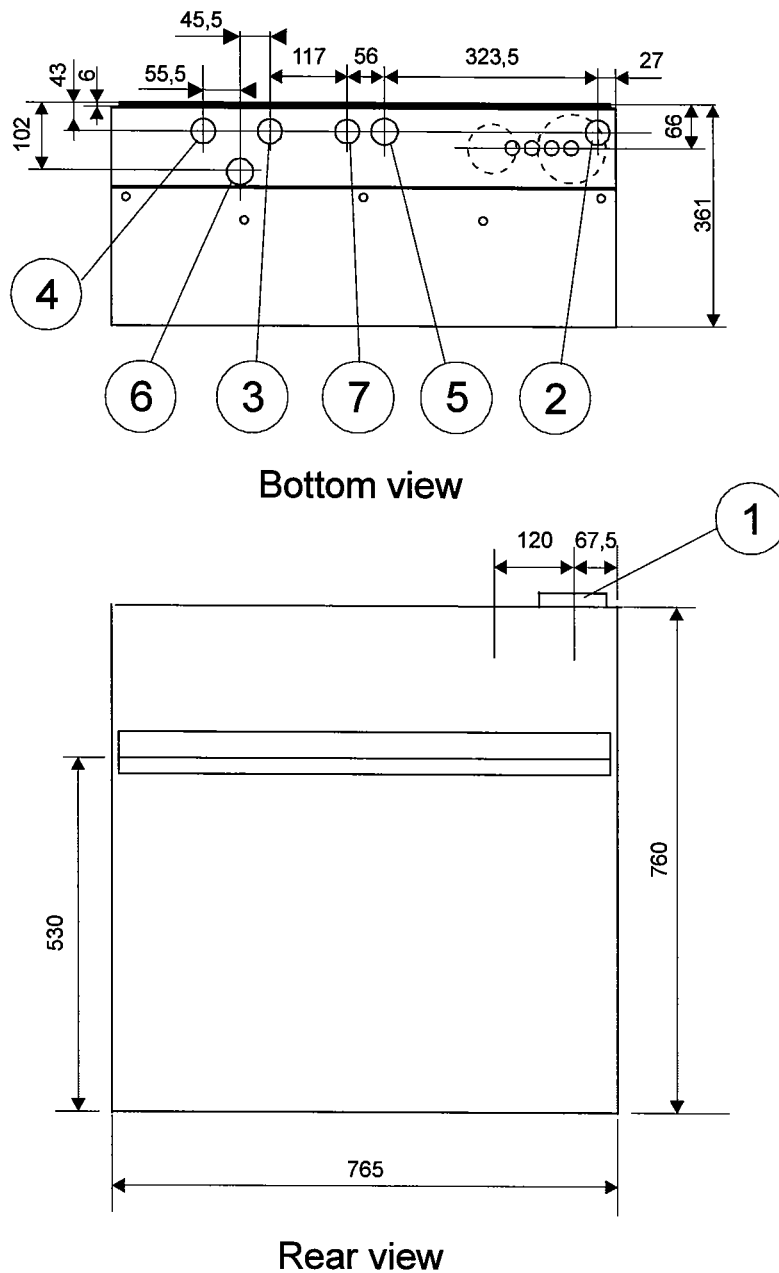

## 2.0 OPERATION

### 2.1 Principle

#### 2.1.1 Components

Refer to Figure 2

Fig.2

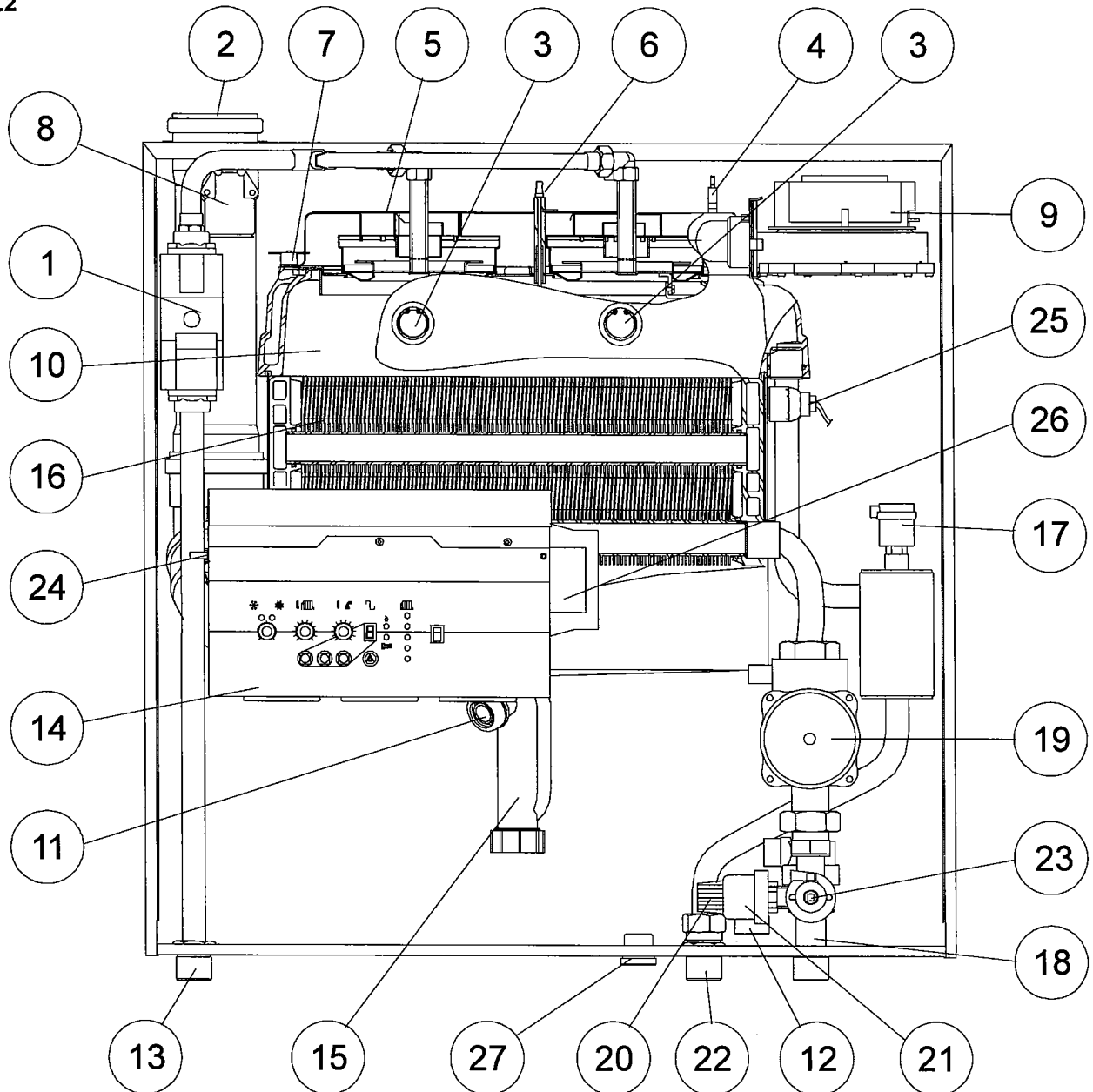

- |   |   |   |
|---|---|---|
| 1. 24 V gas valve (solenoid valve and regulator). | 10. Combustion chamber.                 | 19. 230 V 3 speed circulating pump.           |
| 2. Combustion products flue.                      | 11. Condensate drain.                   | 20. Pressure relief valve (3 bar).            |
| 3. Sight glass.                                   | 12. Pressure relief valve discharge.    | 21. Water pressure sensor.                    |
| 4. Ignition Electrode.                            | 13. Gas supply.                         | 22. Heating flow.                             |
| 5. Gas burner.                                    | 14. Microprocessor based control panel. | 23. Drain cock and filter.                    |
| 6. Ionisation (flame) probe.                      | 15. Condensate trap.                    | 24. Flue gas temperature safety cut-out.      |
| 7. Overheat safety thermostat.                    | 16. Finned tube heat exchanger.         | 25. Heating temperature sensor.               |
| 8. Ignition transformer.                          | 17. Automatic air vent.                 | 26. Mains transformer 230 V.                  |
| 9. Fan (39 V/230 V).                              | 18. Heating return manifold.            | 27. Connection for primary return, if fitted. |

## 2.1.2 Control Panel

**Fig. 3**

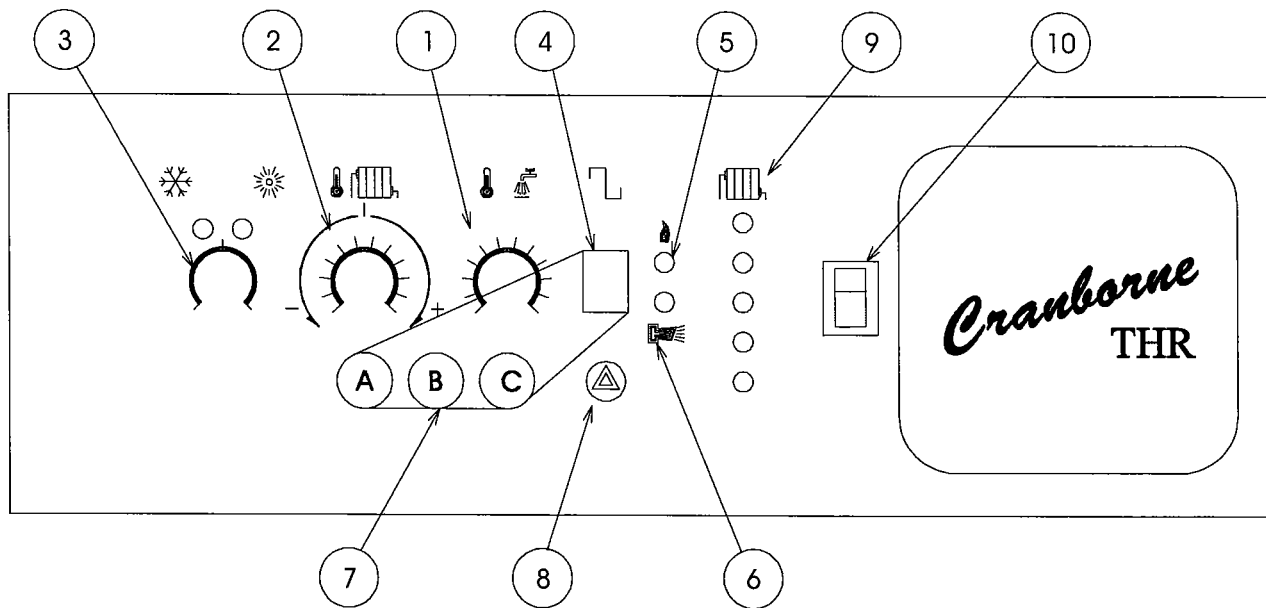

The control panel (refer to Figure 3) is equipped with the following items:-

- 1) A domestic hot water temperature control potentiometer - only used when optional DHW kit is fitted and indirect hot water tank installed. (refer to section 7.0).
- 2) A heating temperature control potentiometer or a warmer/cooler control potentiometer when boiler is fitted with the optional outside sensor. (see section 2.2.2).
- 3) A Winter/Summer switch giving heating and hot water in the winter position and hot water only in the summer position. On heating only systems, the switch should remain in the winter position.
- 4) A sequence display showing a single character. Each character shows the current status of the boiler, be it during the ignition sequence or in an alarm condition.
- 5) A 'flame on' indicator lamp.
- 6) A 'fault' indicator lamp.
- 7) Three buttons marked 'A', 'B' and 'C', which are used during commissioning by the installer. They can also be used to modify the heating parameters when an outside sensor has been added as an option.
- 8) A reset button for use if a fault occurs.
- 9) An array of lamps to show the pressure within the heating circuit.
- 10) An 'on/off' switch.



### 2.1.3 Operating Diagram / Sequence

For operating diagram, refer to Figure 4

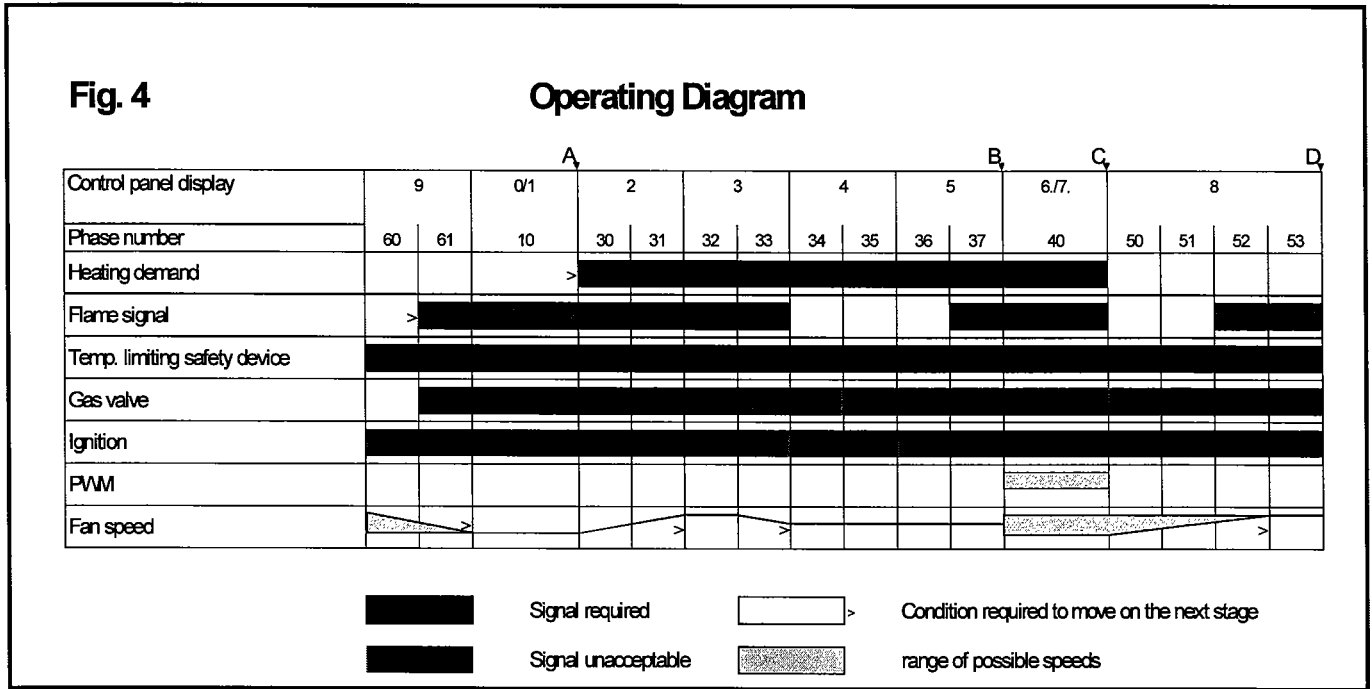

**Phase 10: Stand-by**

The boiler is on standby awaiting a demand for heat. Point A is the Start-up position initiated by the boiler regulator or the domestic hot water regulator.

**Phase 30-31: Fan run up time**

This time ends as soon as the fan motor speed reaches the load programmed for pre-purge.

**Phase 32: Pre-purge time**

This time ends as soon as the programmed ignition load is reached.

**Phase 34: Pre-ignition time (3 seconds)**

The ignition spark is brought on prior to the opening of the gas valve which occurs at the beginning of phase 35.

**Phase 35-36-37: Safety time (3 seconds)**

A flame signal should be present (ionisation current > 2.8  $\mu$ A) before the safety time has elapsed. If this does not occur, another ignition attempt is made.

**Phase 40: (points B - C) Burner operation**

Burner operation following a demand for hot water (display 6) or heating (display 7).

**Phase 50-53: (points C - D) Shut-down**

The change of operating position to stand-by is referred to as a 'shut-down' and occurs when the demand for heat ceases. The gas valve closes and the combustion gases are evacuated by a post-purge.

**Phase 50-51: Blocking time**

Blocking time for test purposes (about 2 seconds).

**Phase 52: Closure time**

Time required to arrive at the programmed air flow rate.

**Phase 53: Post-purge time (3 seconds)**

The fan remains on during the post-purge period.

**Phase 60-61: Return to initial position**

Obligatory passage from the shut-down position to standby. This phase is also used to bring the gas control box to the stand-by position after exceptional events such as a reset.

## 2.1.4 Principle of Air/Gas Servo-Control System

The gas valve is controlled by the air pressure supplied by the fan, thus guaranteeing a correct air/gas ratio over the whole range of operation (constant CO<sub>2</sub>). The ratio remains constant despite

any pressure drop in the combustion products outlet or the air intake. The air-gas link is pneumatic. Refer to Figure 5.

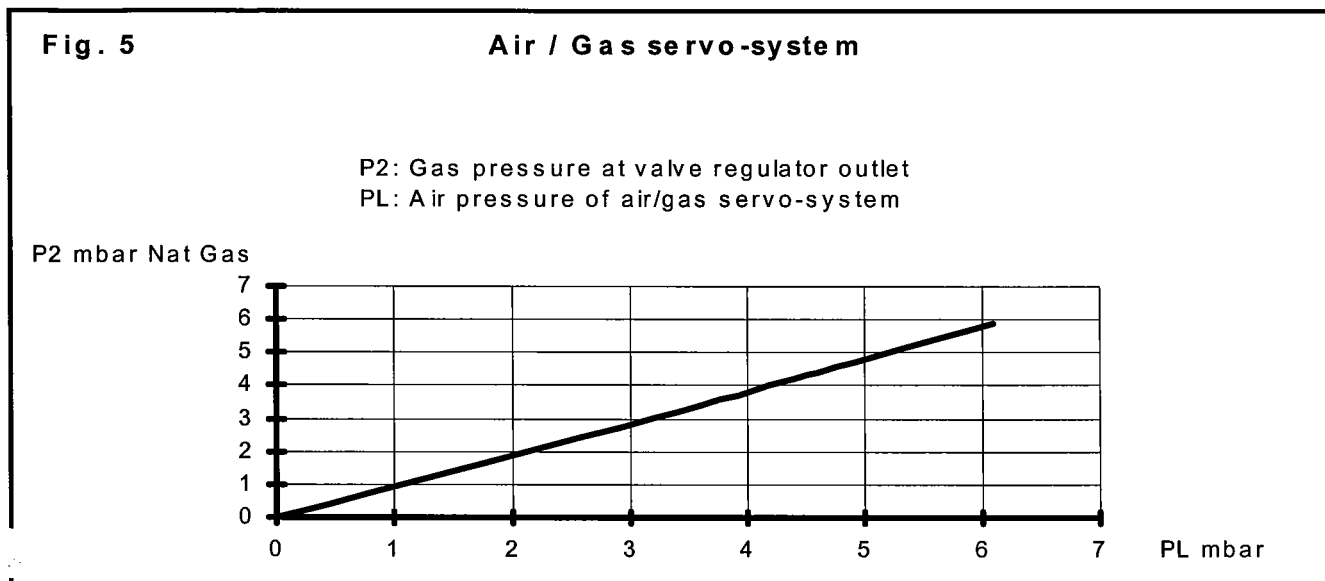

## 2.1.5 Air Pressure Variation Procedure

The boiler has a 230 Volt variable speed fan. It is controlled by the regulator which calculates the speed needed, at any given time, to produce the required pressure.

## 2.1.6 Emission of Pollutants

The boiler is fitted with a high performance pre-mix burner. CO and NO<sub>x</sub> emissions are within the values laid down by the most demanding of quality standards.

## 2.2 Control Options

### 2.2.1 The Basic Boiler Control

No outside or room sensor fitted, refer to Figure 6. Manual adjustment of heating flow and domestic hot water temperatures (if hot water tank is fitted) on the boiler control panel.

The heating regulator defines the heat output required to achieve the heating and hot water settings entered by the user. These are set using the temperature knobs for the boiler flow and hot water. A winter/summer switch can be used to switch from hot water only (summer position) to heating and hot water (winter position).

Whether the switch is set to winter or summer, the boiler is protected against freezing when the temperature drops below 5°C.

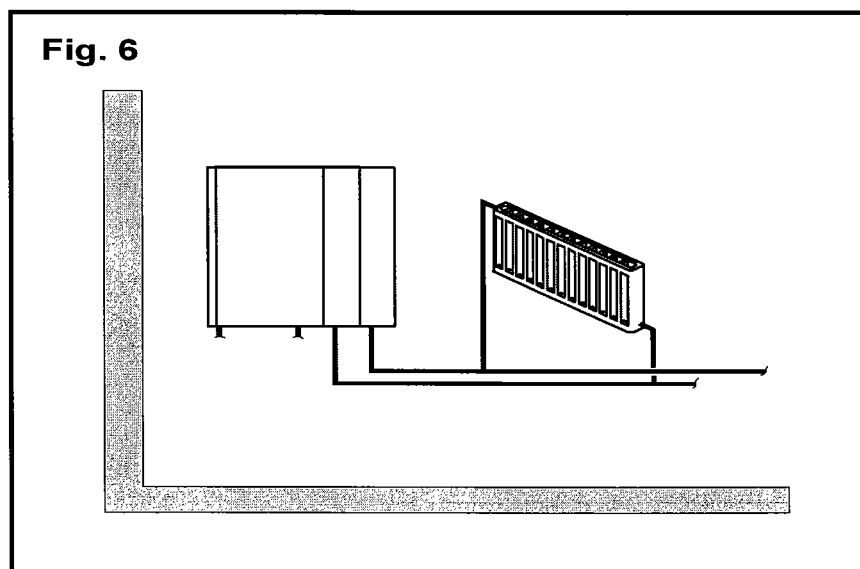

## 2.2.2 Boiler Fitted with Outside Sensor

Refer to Figure 7.

Correction of flow temperature and adjustment of hot water temperature (if hot water tank is fitted) on the boiler control panel.

### 2.2.2.1 Principle

The hot water temperature setting is adjusted using the hot water temperature control knob on the control panel.

With the summer/winter switch set to the winter position, the regulator automatically switches between winter and summer. The boiler provides only hot water

when the average outdoor temperature exceeds 19°C. Otherwise, the boiler provides heating and hot water.

The heating temperature control knob becomes inactive and the heating flow temperature is regulated as a function of the real outside temperature conditions. This is achieved using the heating curves integrated into the regulator itself. Refer to Figure 8.

The slope of this curve is pre-set to an average value, but can be corrected using the heating knob and button 'C' located on the control panel, to a warmer or cooler condition (shifted parallel). Once this parameter has been set, the heating system becomes completely independent, the heating flow temperature varying automatically according to the outside temperature, and will produce room temperatures that are finely calculated to give the optimum performance.

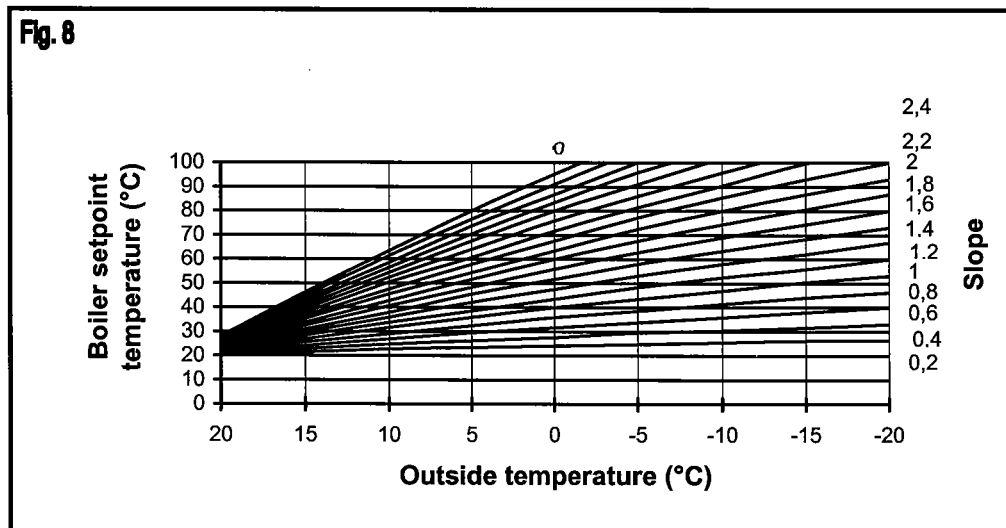
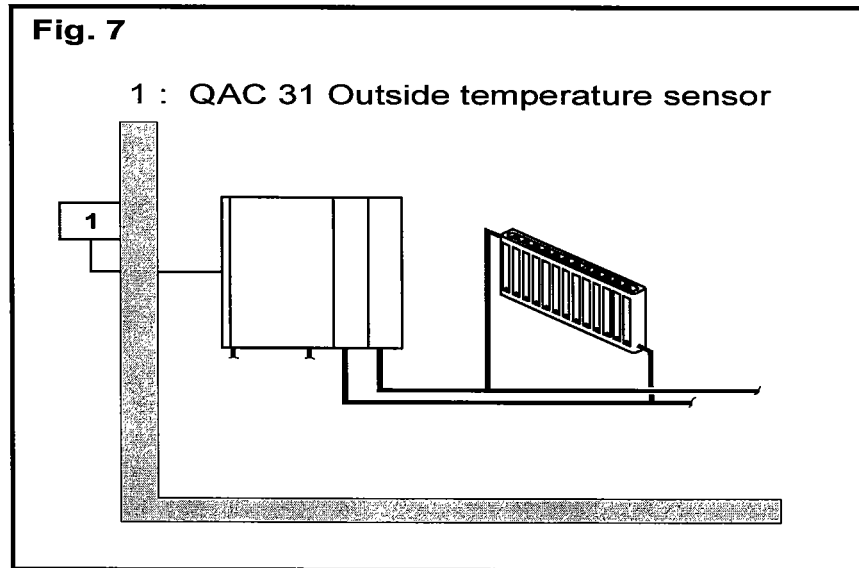

### 2.2.2.2 Modifying Heating Parameters

#### a) Under floor heating.

The heating curve slope is factory pre-set to 1.5 to cater for heating by radiator. This value requires changing to 0.8 when used with under floor heating. To change the parameter, locate the three buttons A, B and C on the control panel, and press them simultaneously until a 'flashing L' appears on the

display, followed by a 'flashing I I'. The slope has now been corrected. It is however possible to refine the following parameters according to the precise needs of the installation (see section 2.2.2.2.c) Modifying parameters) by increasing or reducing the temperature setting by a few degrees.

## b) Radiator heating.

The factory settings correspond to heating by radiator. The characteristics of the building (e.g. insulation, heating surface) may mean that the setting needs adjusting in order to obtain a higher or lower level of heating. This involves modifying the heating curve parameters (refer to section 2.2.2.2.c) Modifying parameters).

## c) Modifying parameters

Adjust the heating knob to the right to obtain a warmer temperature setting (Room temperature warmer) (max. + 3°C) and to the left for a cooler setting (max - 3°C). Press button C until an 'F' appears on the display (about 3 s). The parameters have now been adopted by the system.

If the radiator temperature setting needs to be increased by more than 3 degrees, this operation can be repeated, but first wait for 10 minutes to allow the regulator time to register the new parameters properly. The inherent inertia in buildings and their heating systems means that it may take several hours to react to a change, so it is better not to change this parameter too often.

To return to the standard parameters, press the three buttons A, B and C simultaneously until an L appears on the display.

## 2.2.3 Boiler Fitted with Inside and Outside Sensors

All the controls, settings, overrides and corrections for heating flow/hot water temperatures (if optional hot water tank is fitted) can be carried out using the room sensor. Refer to Figure 9.

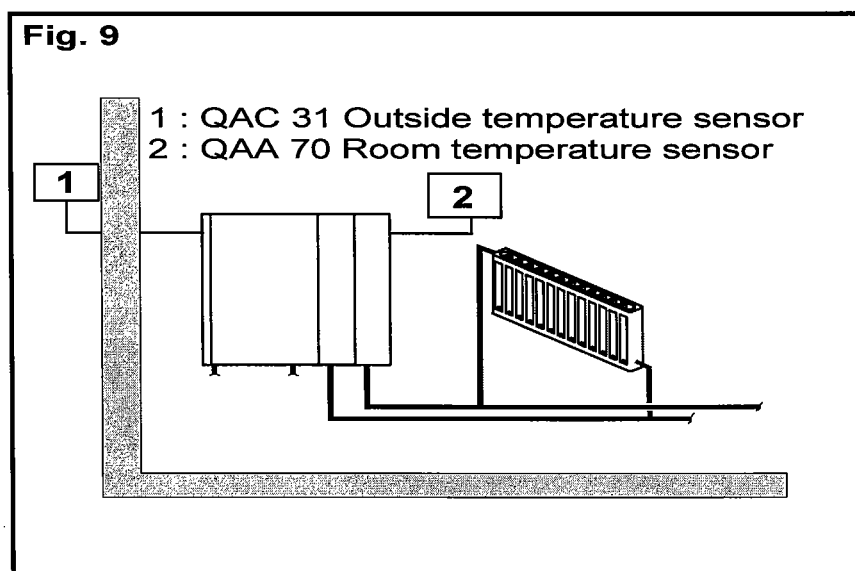

### 2.2.3.1 Principle

This version is designed to provide optimum comfort. As well as the functions linked to the outside sensor described for the model above, the system also has a room sensor. This QAA70 room sensor provides the following functions:

- Compensation for ambient conditions.
- The ability to programme three daily periods for heating or hot water.
- A simple programme override to switch the system off either momentarily or for longer periods (e.g. holidays).
- An ambient temperature setting for each programmed period.
- A setting for the hot water temperature.
- A display showing the time, the outside temperature, the ambient temperature, the boiler temperature, the hot water temperature and indicating the presence of any faults on the boiler system.
- The ability to anticipate and defer water heating. The hot water tank will start being fed with hot water one hour before the heating period and this will continue until 10 minutes after the end of this period.

When a demand for a domestic hot water is made during a period of reduced heating, the boiler automatically ensures that the water is at the hot water temperature setting.

### 2.2.3.2 Adjustments

Fitting the QAA70 module on the boiler cancels the functions of the heating and hot water temperature knobs on the boiler control panel. The expected temperatures must be set on the QAA70 sensor (refer to separate technical instructions).

#### a) Winter/Summer Switch

When the winter/summer switch is set to the winter position, the boiler can switch automatically from winter to summer operation. Summer operation is active when the outside temperature, measured over the previous 24 hours, exceeds the set point by 1°C. i.e. it reaches 20°C. When summer operation is active it can be overridden temporarily by pressing simultaneously the 'clock' and 'house' buttons on the QAA70.

The system automatically returns to summer operation, when the outside temperature measured over the previous 24 hours is at least 1 °C less than the set point. i.e. below 18°C. The 19°C set point can only be changed by using a special interface unit. When the winter/summer switch is set to the summer position, the boiler provides hot water only (if a hot water tank is fitted).

### **b) Ambient Conditions Compensation Function**

This function can be used to correct the boiler flow temperature according to the real ambient temperature measured by the QAA70 sensor. The function should be activated or deactivated when the boiler is commissioned, depending on the position of the sensor. The function should be inactive if the QAA70 is placed outside the heated space, in a room with another heating system, in a position exposed to sunshine, or in a room where the radiators are controlled by thermostatic valves. When the ambient conditions compensation function is inactive, the QAA70 becomes a remote control acting on the heat curve to cater for the drop in temperature from daytime to night-time.

The ambient conditions compensation function is activated by pressing buttons **A** and **C** on the control panel simultaneously for 5 seconds until the  $\Gamma$  symbol appears on the display. The function is switched off by pressing buttons **A** and **C** simultaneously for 5 seconds until the  $\perp$  appears on the display.

### **c) Auto-Adapt Function**

This function automatically corrects the heating curve based on a measurement of the real ambient temperature.

The corrected loss can be read via the special interface unit. The function should not be active in the installation situations described above for the ambient conditions compensation. The auto-adapt function is activated by pressing buttons **B** and **C** on the control panel simultaneously for 5 seconds until the  $\square$  symbol appears on the display. The function is switched off by pressing buttons **B** and **C** simultaneously for 5 seconds until the  $\sqcup$  symbol appears on the display.

## **2.3 Functions Common to the Control Options**

**Note:** For these functions to work (frost protect, pump kick, automatic winter/summer switching, anti-legionella etc.), the on/off switch must not be operated (needs to be kept permanently in the "on" position).

### **2.3.1 Frost Protect Function ( with QAC 31 and / or QAA 70)**

#### **a) Frost protection for the boiler**

When boiler temperature falls below 5°C the burner and the heating circuit pump are switched on. When the temperature increases and exceeds 15°C the

burner is switched off and the pump continues to circulate for 10 minutes.

#### **b) Frost protection for the installation.**

The heating pump will operate automatically either intermittently, if the outside temperature falls below 1.5°C, or continuously, if the temperature falls below – 10°C.

#### **c) Frost protection for the building.**

When the boiler is equipped with a QAA70, protection is provided by maintaining ambient temperatures at a minimum of 5°C.

#### **d) Frost protection for domestic hot water.**

When hot water production is not required, the circuit is maintained automatically at a minimum temperature of 4°C.

## **2.3.2 Anti-Legionella Function**

To provide a degree of protection against the development of pathogenic bacteria in the hot water tank during prolonged shut-downs, the domestic hot water needs to be heated once a week to above 60°C. The anti-legionella function is used for this purpose and heats the hot water storage tank, if fitted, to an "anti-legionella" temperature of 65°C automatically on a weekly basis.

## **2.3.3 Pump Overrun**

At the end of a heating period, the circulating pump remains on for a further 10 minutes overrun.

In hot water storage systems, at the end of a water heating period, the circulating pump remains on until the boiler temperature drops below 70°C. During this pump overrun period, the selector valve remains in the "domestic hot water" position.

## **2.3.4 Selector Valve and Pump Kick**

If, during shut-down periods, either the heating circuit has not operated or the selector valve has not been switched for more than approximately 24 hours, these are activated for a period of about 5 seconds.

## **2.3.5 Boiler Overheat Protection**

The regulator incorporates a temperature limiting function that will switch the burner off when the temperature of the water in the boiler reaches the maximum of 85°C. The circulating pump will remain on until the real temperature of the water in the boiler drops below 79°C when the burner is allowed to restart.

A separate boiler overheat thermostat is also fitted which, when operated, switches on the heating circuit circulating pump and the fan motor for 10 minutes. The selector valve is also switched to the 'heating' position and an alarm is generated on the boiler. This is a lockout condition which should be investigated prior to manually resetting by pressing the 'reset' button on the control panel and returning the boiler to normal operation.

### 2.3.6 Burner Short Cycling Protection Function

The minimum time that the burner can operate is set to 60 seconds.

### 2.3.7 Sweep Function

(display code: flashing '5').

The sweep function is activated by pressing button 'B' on the control panel, for at least one second, when a demand for heating is made so that the system comes on. The regulator's internal 'on-off' functions remain inactive in this situation. The heating then operates at maximum heat output, to allow the taking of flue gas measurements, until the temperature controller responds.

### 2.3.8 TUV Function

(display code: flashing '4').

Pressing 'A' and 'B' buttons on the control panel for at least one second activates the TUV function, i.e. the internal regulator/temperature controller function becomes inactive. The heating then operates at maximum heat output until the safety temperature limiter responds. Releasing either of the two buttons interrupts the TUV function.

### 2.3.9 Regulator 'Off' Function

(display code: flashing '7').

Pressing the 'A' button only on the control panel, for at least 3 seconds, activates the 'regulator stop' function. This allows the fan speed (and therefore the heat output) to be adjusted manually on the hot water setting potentiometer (e.g. for adjusting the gas pressures etc.). The boiler operates in its heating mode with the internal "on-off" regulator and the temperature controller function active. The 'regulator off' function is ended by pressing the button again or by switching the burner off.

### 2.4 Heat Exchanger/Condenser

The heat exchanger is of sufficient heat transfer area that, when combined with the water-cooled combustion chamber above, it functions as both primary heat exchanger and condensing unit. Condensation occurs on the tube walls where the temperature is below the dew point for the combustion products. Refer to Figure 10 for the nett efficiency curve with respect to return water temperature for both maximum and minimum heat inputs.

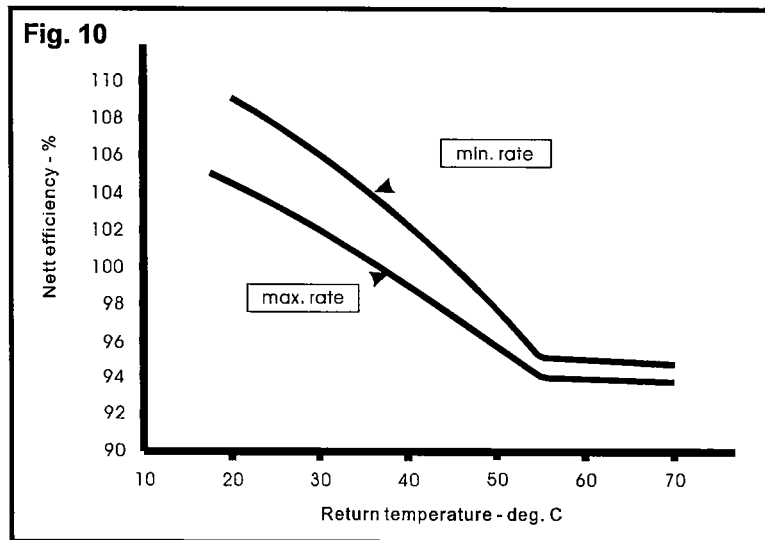

## 2.5 Gas Valve

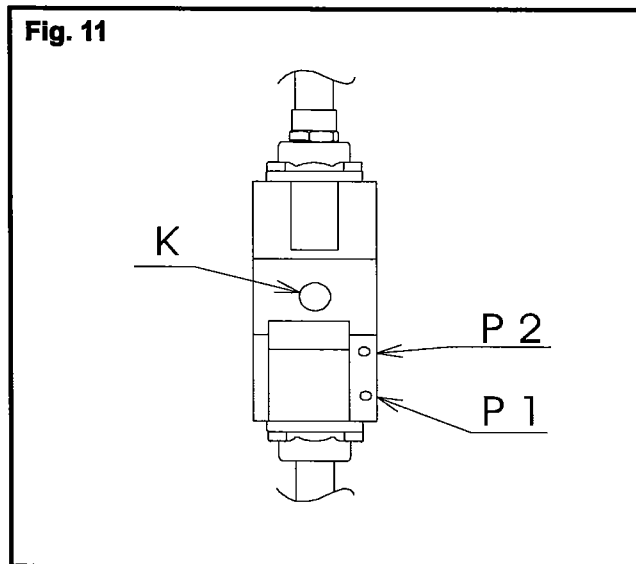

$P_1$  = inlet gas pressure.

$P_2$  = outlet gas pressure to burner

**K** = Adjustment screw used to produce a parallel shift in the gas characteristic. This screw is factory pre-set and should not normally require any adjustment, even for a change of gas. If however it should prove necessary to make an adjustment, this must only be

carried out with the burner **operating at minimum output** using a small scale pressure gauge (0 to 10 mmWG) and a **CO<sub>2</sub> & CO analyser**. Turning the screw clockwise increases the pressure measured at  $P_2$ .

### 3.0 DIGITAL DISPLAY

#### 3.1 Normal Operation

Display	Meaning
0	Awaiting demand for heating or hot water
1	Shunt 6 not present - switch open
2-3	Fan speed rise time/ Pre-ventilation
4	Pre-ignition – Ignition
5	Flame presence verification
6	Burner operating on hot water
7	Burner operating on heating
8	End of demand for heating or hot water, post-ventilation
9	Return to initial position, reinitialise gas control parameters (fan off)

#### 3.2 List of Display Codes

The 'ALARM' lamp remains off and the display flashes. If several signals occur, the code with the highest priority is displayed.

Display	Meaning	Priority
1	Boiler potentiometer setting absent	1
2	Hot water potentiometer setting absent	1
4	TUV function active	1
5	Sweep function active	1
7	Regular off function active	1
8	Domestic hot water sensor: Circuit broken	1
0	Domestic hot water sensor: Short circuit	1
A	Anti-legionella function active	2
C	Sweep button closed after RESET/Unlock	1
D	TUV button closed after RESET/Unlock	1
E	Forced intermission active	2
F	Warmer / cooler correction executed	1
L	Revert to standard values	1
P	Q1 heating circuit pump kit active	2
U	Q3 hot water pump or selector valve kick active	2

#### 3.3 List of Alarm Codes

The 'ALARM' lamp remains on and the display flashes.

Display	Fault	Possible Cause / Solution
0	Incorrect fan speed during pre-ventilation phase	Check parameter DA3.
2	Overheat thermostat or flue gas thermostat activated	Check water pressure and flow (Pmin. = 1 bar). Purge the installation correctly.
4	Flame fault or premature flame signal	1 The flame does not appear: no gas, gas valve will not open, significant gas valve adjustment error, defective HT transformer, HT lead, or HT electrode. 2 The flame only appears for 3 seconds: Live/neutral reversed, defective ionisation probe or ionisation probe lead.
5	Incorrect fan speed at maximum load	Check parameter DA4.
6	Fan speed rise time too long	Check that the fan is able to rotate freely.
9		
A	Maximum fan speed exceeded during pre-ventilation phase	1 Check mains voltage (too high). 2 Check that neither the flue nor the fan air inlet are blocked. 3 Check parameters DA.
H	Boiler sensor circuit broken	Replace boiler sensor.
L	Boiler sensor circuit broken	Replace boiler sensor.
C	Boiler water pressure too low	1 Check the water pressure in the heating circuit. 2 Check that the pressure sensor is working – accessed by removing the plastic cover.

All other codes result from internal faults



## 4.0 INSTALLATION

### 4.1 Related Documents

**The Gas Safety (Installation and Use) Regulations 1998 (as amended).** It is law that all gas appliances are installed by competent persons, in accordance with the above regulations. Failure to install appliances correctly could lead to prosecution. It is in your own interest, and that of safety, to ensure that this law is complied with.

The installation of the boiler **MUST** be in accordance with the relevant requirements of the Gas Safety Regulations, Building Regulations, IEE Regulations and the Water Supply (Water Fittings) Regulations.

The installation should also be in accordance with any relevant requirements of the local gas region and local authority and the relevant recommendations of the following documents: -

#### British Standards

**BS 6891:** Specification for installation of low pressure gas pipework of up to 28mm.

**BS 6798:** Specification for installation of gas-fired boilers of rated input not exceeding 70 kW net.

**BS 5449:** Specification for forced circulation hot water central heating systems for domestic purposes.

**BS 5546:** Specification for installation of gas hot water supplies for domestic purposes.

**BS 5440:** Installation and maintenance of flues and ventilation for gas appliances of rated input not exceeding 70 kW net. **Part 1:** Specification for installation and maintenance of flues. **Part 2:** Specification for installation and maintenance of ventilation for gas appliances.

**BS 7074:** Application, selection and installation of expansion vessels and ancillary equipment for sealed water systems. **Part 1:** Code of practice for domestic heating and hot water supply. **Part 2:** Code of practice for low and medium temperature hot water heating systems.

**BS 6700:** Design, installation, testing and maintenance of services supplying water for domestic use within buildings.

**CP 342:** Code of practice for centralized hot water supply. **Part 2:** Buildings other than individual dwellings.

#### I. Gas E. Publications

**IGE/UP/1** Soundness testing and purging of industrial and commercial gas installations.

**IGE/UP/1A** Soundness testing and direct purging of small low pressure industrial and commercial natural gas installations.

**IGE/UP/2** Gas installation pipework, boosters and compressors in industrial and commercial premises.

**IGE/UP/7** Gas installations in timber frame buildings.

**NOTE:** The boiler is only suitable for installation in a sealed system and must not be used with an open vented system.

### 4.2 Location of Boiler

The boiler can be installed on the inner face of an external wall – and some internal walls – providing they are flat, vertical and capable of adequately supporting the weight of the boiler and any ancillary equipment.

The boiler may be installed in any room or internal space, although particular attention is drawn to the requirements of the current I.E.E Wiring Regulations and, in Scotland, the electrical provisions of the Building Regulations applicable in Scotland with respect to the installation of the boiler in a room or internal space containing a bath or shower. Where installation is in a room containing a bath or shower, any electrical switch or boiler control utilising mains electricity should be situated so that it cannot be touched by a person using the bath or shower.

Where installation will be in an unusual location, special procedures may be necessary and **BS 6798** gives detailed guidance on this subject.

A compartment used to enclose the boiler **MUST** be designed and constructed specially for this purpose. An existing cupboard or compartment may be used provided it is modified for the purpose. Details of essential features of cupboard/compartment design, including airing cupboard installations, are given in **BS 6798**.

In siting the boiler, the following limitations **MUST** be observed:

**a)** The position selected for installation **MUST** allow adequate space for servicing in front of the boiler and for air circulation around the boiler.

**b)** This position **MUST** also permit the provision of a satisfactory flue termination.

**NOTE:** If the boiler is to be fitted in a timber framed building, it should be fitted in accordance with the IGE publication **IGE/UP/7**. If in doubt, advice must be sought from the Local Gas Region.

When siting the boiler, provision must be made for the disposal of the condensate, refer to Section 4.7.

The pressure relief valve connection should be routed to an external, visible point where the discharge of steam or water cannot create a hazard to persons or property. **BS 5449** refers.

### 4.3 Air Supply

Detailed recommendations for air supply and ventilation requirements are given in **BS 5440: Part 2**. The following notes are intended to give general guidance. In all cases there must be provision for an adequate supply of air for both combustion, where applicable, and ventilation in addition to that required for any other appliance.

**a) For room-sealed systems**

Where the boiler is to be installed in a room or internal space, the boiler does not require the room or internal space containing it to have a permanent air vent. Where the boiler is to be installed in a cupboard or compartment, permanent high and low level air vents are required for cooling purposes in the cupboard or

compartment. Both vents must communicate with the outside air on the same wall or to the same internal space. The minimum effective free area of the permanent air vents required in the cupboard or compartment are given in Table 2.

**Table 2 Minimum Air Vent Free Areas**

Position of Air Vents	Air to Room or Internal Space	Air Direct to Outside
High level	500 cm <sup>2</sup>	250 cm <sup>2</sup>
	77.5 in <sup>2</sup>	39 in <sup>2</sup>
Low level	500 cm <sup>2</sup>	250 cm <sup>2</sup>
	77.5 in <sup>2</sup>	39 in <sup>2</sup>

**b) For natural draught open flue system:**

Detailed requirements are given in **BS 5440 Part 2**.

**4.4 Water Circulation System**

A suitable expansion vessel must be fitted to the system external to the boiler and must be sized to accommodate the expansion of the total water content of the sealed system.

**BS 7074** gives guidance in this subject.

The central heating system should be in accordance with the relevant recommendations given in **BS 6798** and, in addition, for small bore and microbore systems **BS 5449**. The domestic hot water system, if applicable, should be in accordance with the relevant recommendations of **BS 5546**.

Copper tubing, to **BS EN 1057** is recommended for water carrying pipework.

**4.5 Mounting and Clearances**

The boiler is supplied with a wall plate which must be securely attached to the wall. Positions of the mounting holes and the position of the wall plate relative to the mounting bracket fixed to the rear of the boiler are shown in Figure 12. When mounting the boiler in an internal corner, the minimum clearances shown in Figure 12 must be observed.

**Fig. 12**

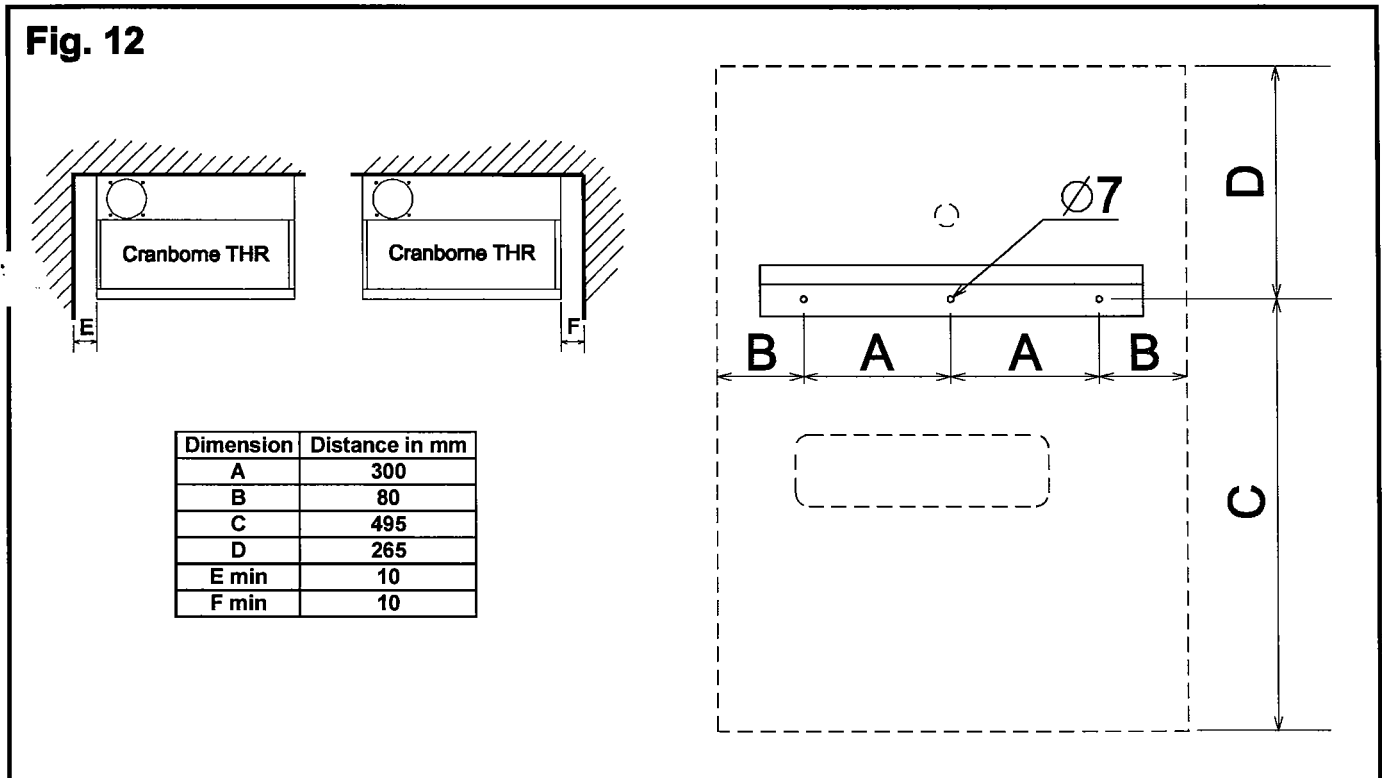

**Fig. 20**

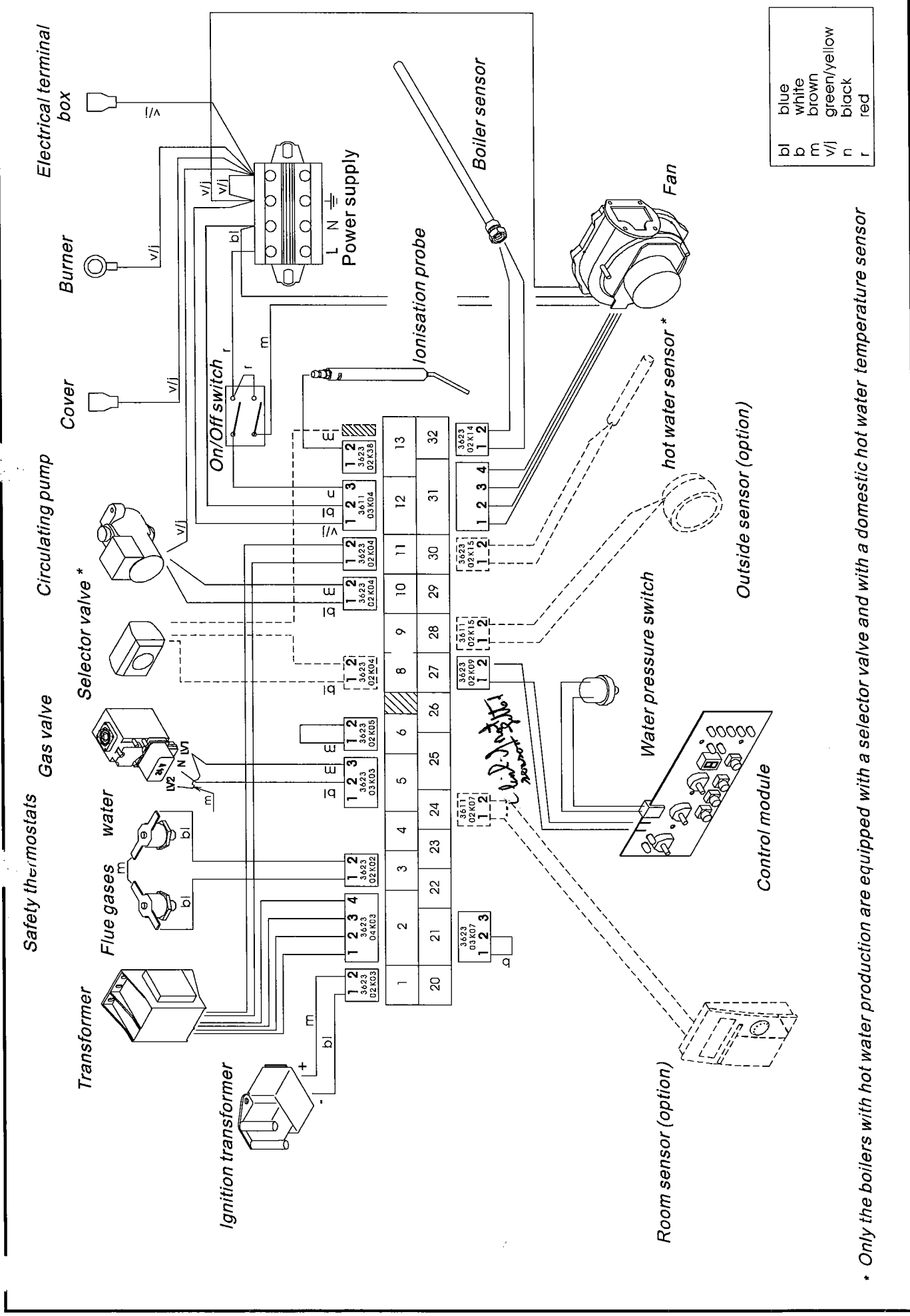

\* Only the boilers with hot water production are equipped with a selector valve and with a domestic hot water temperature sensor

#### 4.6 Spacer Back Plate (Supplied as an option)

The spacer back plate allows the connection pipes (gas, water flow, water return etc.) to be run up behind the boiler where the system connections are located above the boiler. The general layout is shown in Figure 13.

- To assemble the spacer back plate, fit as follows: -
- Fit the wall plate supplied with the boiler to the wall.
  - Hang the spacer back plate on to the wall plate.
  - Hang the boiler onto the spacer back plate.

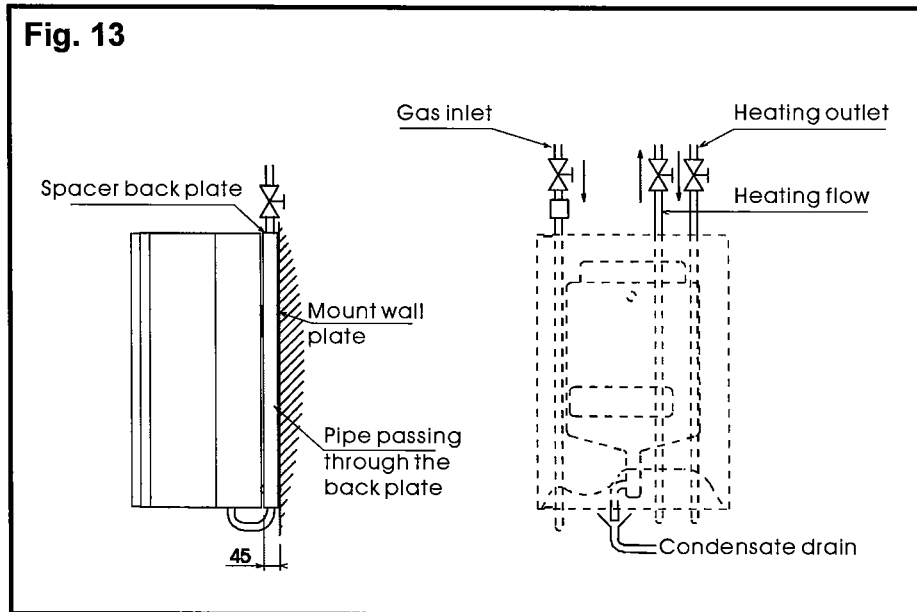

#### 4.7 Ancillary Connections

**a) Expansion vessel** pre-charged to 0.5 bar and suitably sized for the total system volume. Ensure that the vessel(s) is connected correctly and check charge pressure before filling.

**b) Safety pressure relief valve** supplied fitted to the boiler set at 3 bar. Ensure the valve discharge is piped to drain via a tundish and trap.

**c) Condensate drainage siphon trap** supplied fitted to the boiler. Ensure the trap discharge is piped to drain via a tundish and trap using 32 mm dia. PVC pipe. When installing the system, ensure the siphon traps are filled with water before commissioning. These should be inspected twice a year.

**d) Circulating pump** with an air separator and automatic air vent supplied fitted to the boiler. Ensure that the silicon tube from the air vent discharge is terminated inside the tundish.

The heating flow and return pipes must be fitted with isolating valves so that work can be carried out on the boiler if required without draining the installation.

Ensure that the boiler and installation are correctly purged by increasing the water pressure to at least 1 bar (manometer). Check that it is fully purged again a few days after commissioning.

#### 4.8 Water Flow Through the Heat Exchanger

Because of the heat input modulating system and the sensitivity of the temperature sensor located inside the heat exchanger, the heat input supplied by the boiler will follow the flow rate. The flow rate can be set to between 1200 and 2500 litres/hour (0.33 and 0.7 litres/second), according to the installation's rated heat output. To ensure that the heat transfer operates correctly and to avoid any risk of boiling, the flow rate **must** never be less than 1200 litres/hour.

To obtain maximum heat input the installation's nominal flow rate must be calculated to provide for a temperature drop of 20°C between flow and return. A flow rate of approximately 0.6 l/s will give a temperature drop of 20 C.

#### 4.8.1 Pressure/Flow Rate Graphs

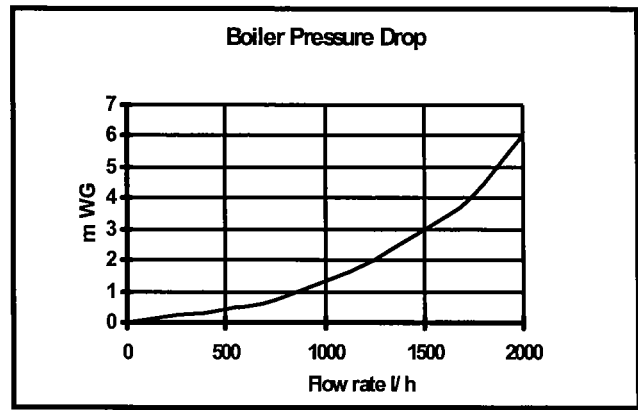
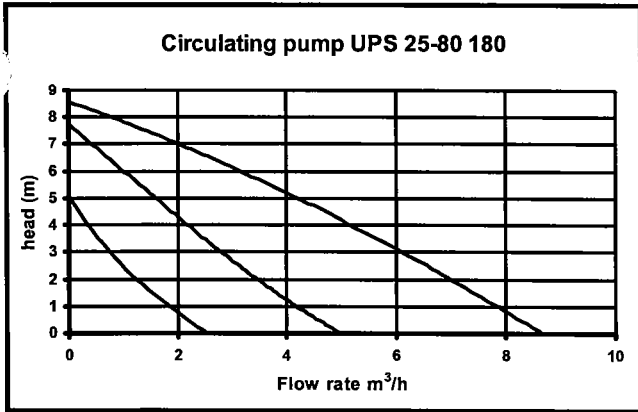

#### 4.8.2 Water Treatment in Multi-metal Circuits

A water treatment product 'INIBAL' is supplied with the boiler located inside the casing.

This **must** be added to the heating circuit when the installation is filled with water. The system should be closed with one litre of 'INIBAL' to one hundred litres of water. If the installation is not new, ALWAYS flush the system using clear water before finally filling it.

#### 4.8.3 Under-floor Heating Installation

If the boiler is to be used to operate an under-floor heating system the following points should be noted: -

##### a) Basic Boiler (without optional sensors)

This boiler model cannot be fitted for use in an under-floor heating system unless it is installed with an independent electronic control.

##### b) Boiler with outside sensor only

To operate the boiler with an outside sensor as part of an under-floor system, the internal regulator parameters have to be changed when commissioning the system. This modification is explained in section 2.2.2.2. Incorrect changes to these parameters may cause damage to the installation.

A safety device has to be fitted in order to comply with the regulations. This manual reset device, which is independent from the regulation system, must cut off the heat supply and should function even in the absence of power or motor fluid. The connection of a switching device to connector No. 6 of the control box satisfies this requirement.

##### c) Boiler with outside sensor and room sensor

Installing this type of boiler as part of an under floor heating system imposes the same constraints as for the previous version, namely that the internal regulator parameters have to be changed (see section 2.2.2.2) and an independent safety device has to be fitted.

#### 4.9 Flue System

##### 4.9.1 General

Detailed recommendations for flue systems are given in **BS 5440 Part 1**. The following notes are intended to give general guidance only.

The Cranborne THR boiler is designed to operate with the following types of flue system: -

a) Standard open flue system with air intake from the correctly ventilated space housing the boiler and 139mm dia. flue connection to a proprietary natural draught vertical flue. European designation for this type of boiler and flue system is **B<sub>23</sub>**.

b) 80/125 mm concentric room sealed, balanced flue system for remote vertical discharge and air entry. European designation is **C<sub>33</sub>**.

c) 80/125 mm concentric room sealed, balanced flue system for 'through the wall' and remote horizontal discharge and air entry. European designation **C<sub>13</sub>**.

**Note:** The flue systems for the room sealed boiler variants are regarded as part of the appliance and approved as such and hence **must** be purchased with the boilers from Hamworthy Heating Ltd. No other type of concentric flue system can be fitted. There are limitations on the length of the room sealed flue systems that must be adhered to.

Details of the different systems are shown in the following sections.

##### 4.9.2 Evacuation Using Standard Open Flue (Type B<sub>23</sub>)

Refer to Figure 14. The boiler is of the condensing type, hence a watertight flue must be used. The combustion products are saturated with water vapour that will continue to condense on the flue walls. The condensate must therefore be collected at the base of the flue and piped to drain. As the condensate is acidic (pH = 4), the use of stainless steel is recommended.

**Note:** Avoid horizontal sections where condensate is liable to collect. Always ensure a minimum slope of 2° upwards in the direction of the flue gas flow is used.

**Fig. 14**

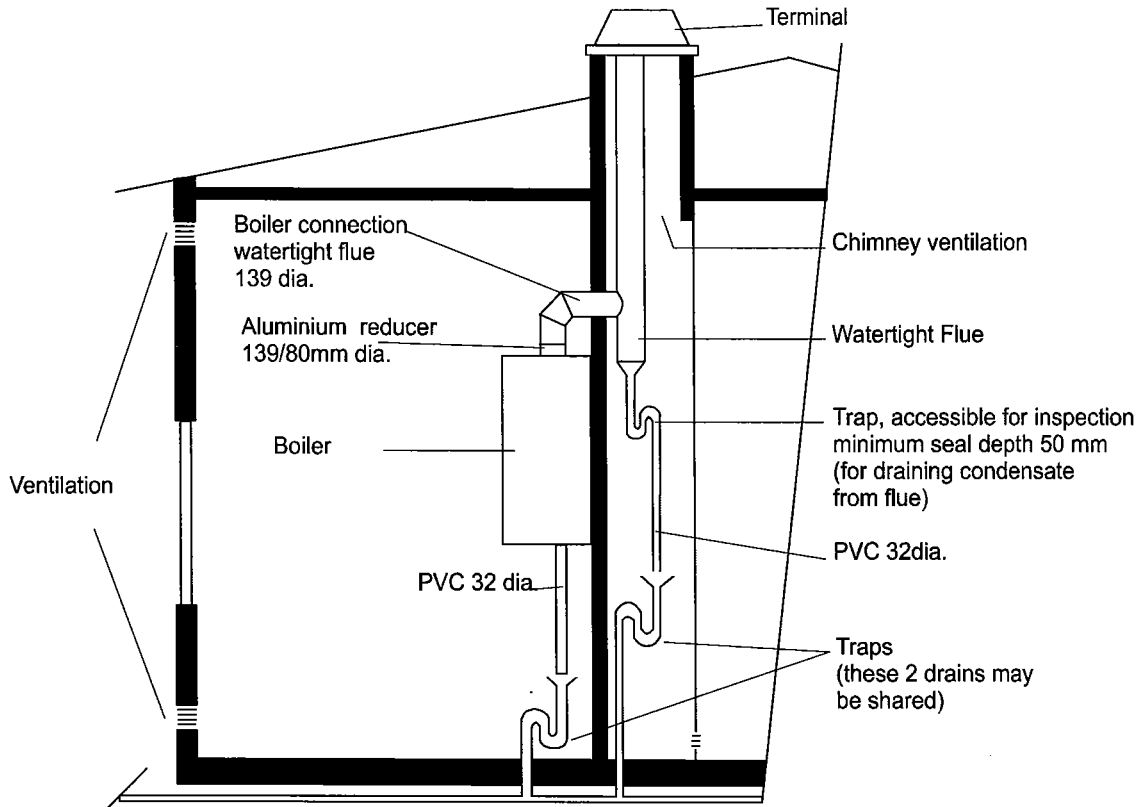

**4.9.3 Evacuation Using a Room Sealed Flue (Type C<sub>13</sub> and C<sub>33</sub>)**

When connected to a vertical or horizontal room sealed flue, the boiler combustion circuit is independent of the ventilation conditions in the room where it is installed. A horizontal room sealed flue must only be installed where the external surface of the wall adjoining the boiler is situated in a well ventilated location.

Two concentric tubes supply air to the burner and evacuate the combustion products. Bends can be added allowing the system to be adapted to most installation situations.

The flue terminal cover is specially designed to withstand wind from all directions as well as rain and snow. Examples are shown in Figure 15. The various

elbows and connection pieces on the flue gas exhaust route and the air intake must be fitted in a leak proof manner in order to avoid flue gas recirculation. It is most important that the seals in the flue system ( casing cover, flue box, flue joints etc.) are kept in good condition and replaced if necessary. The boiler input is automatically reduced by means of the air/gas servo-control system - refer to diagram below. No systematic adjustment is required when commissioning the installation. Only the usual CO and CO<sub>2</sub> checks should be carried out - refer to table 3. The maximum  $\Delta P$  of 100 Pa is obtained with a vertical room sealed 80/125 mm concentric flue of length 8 m including two 45° bends.

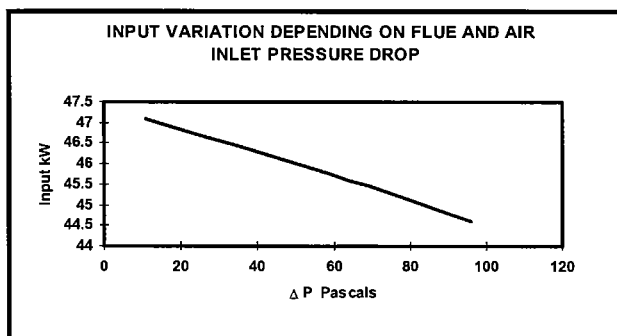

### 4.9.3.1 Evacuation Using Vertical Room Sealed Flue (Type C<sub>33</sub>)

The maximum allowable length of the flue system is 8 metres which includes 2 off 45° bends. Each additional 45° bend reduces the maximum allowable length by 500mm and a 90° bend reduces the length by 1 metre. The flue system is manufactured from plastic tubes, polypropylene for the inner (flue gas) and PVC for the

outer (air). The maximum temperature of the flue gas is 80°C. Refer to Figure 16 for standard parts available to construct the vertical flue system.

**Note:** Items 1 and 2 of figure 16 are supplied with the boiler as standard, items 4 to 9 need to be ordered specifically using the reference numbers detailed.

Fig 16

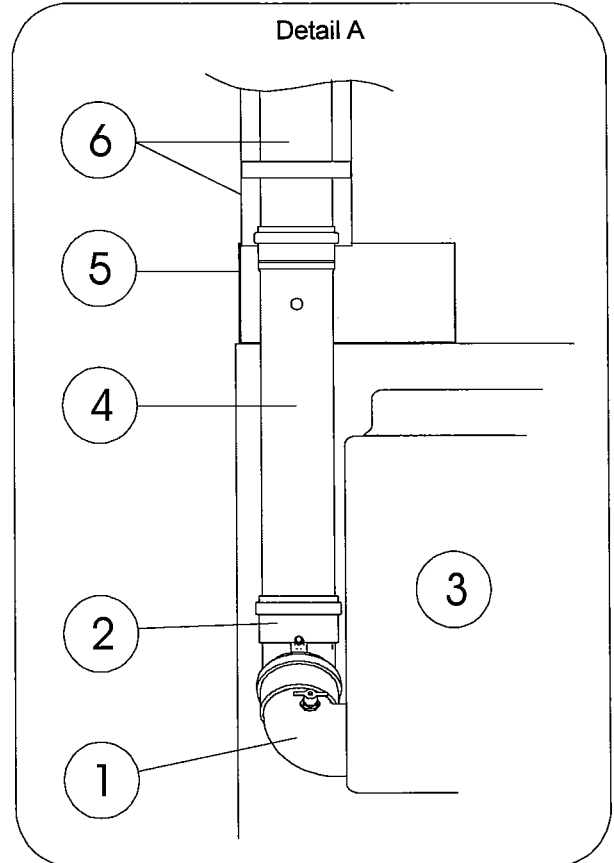
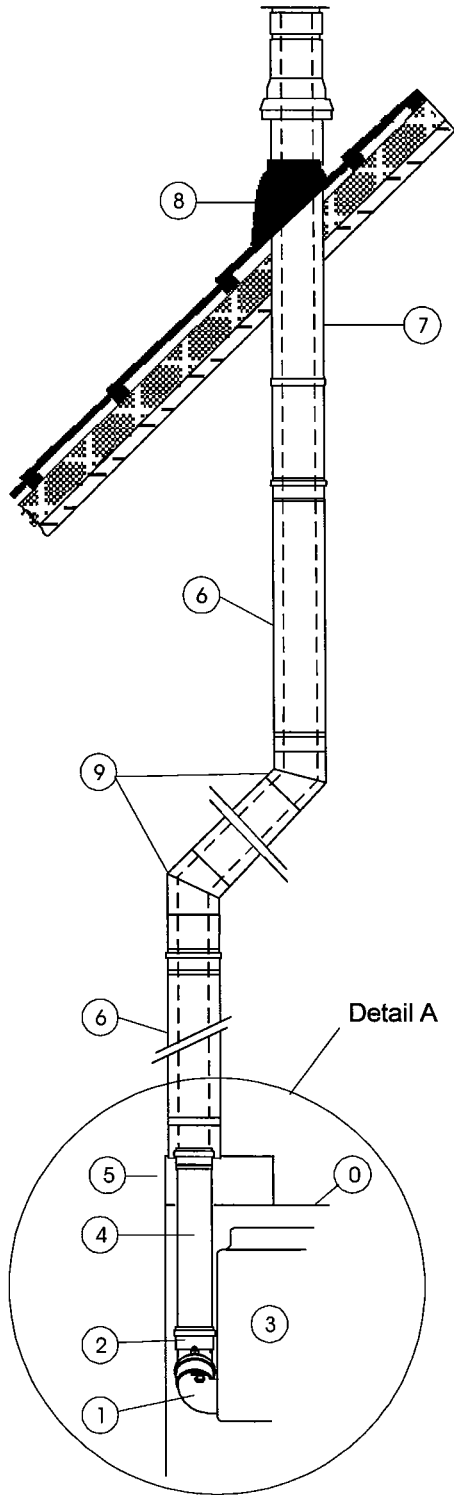

- 0 - Boiler casing
- 1 - 90 deg. bend 80mm dia.
- 2 - 45 deg. Bend 80mm dia.
- 3 - Heat exchanger
- 4 - Flue section 80mm dia., 505mm long (Ref C038)
- 5 - Flue adaptor box (Ref C038)
- 6 - Concentric extension 80/125mm dia.  
Length 500mm (Ref C026)  
Length 1000mm (Ref C027)
- 7 - Concentric vertical flue terminal assembly 80/125mm dia.  
Length 1150mm- black (Ref C025)
- 8 - Roof flashing with adaptable coupling according to roof covering type and slope.  
terracotta 25/45 deg. (Ref C 030)  
terracotta 35/55 deg. (Ref C 031)  
black 35/55 deg. (Ref C032)
- 9 - Concentric bend 80/125mm dia.  
45 deg. (Ref C 028)  
90 deg. (Ref C 029)

Fig. 15

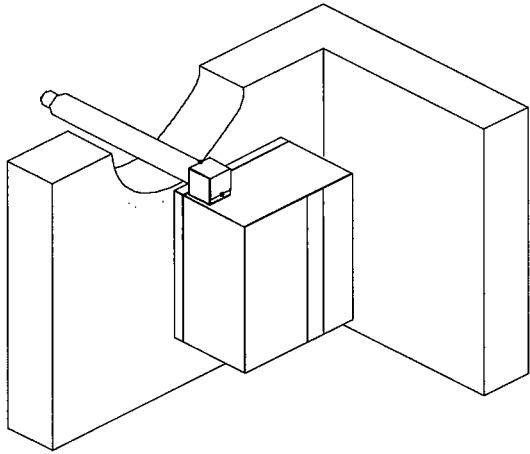

HORIZONTAL ROOM SEALED FLUE INSTALLATION

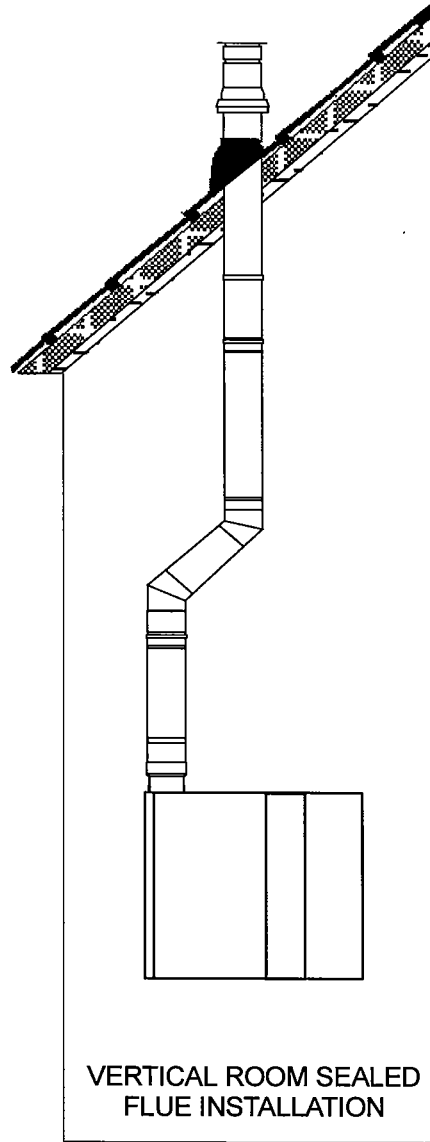
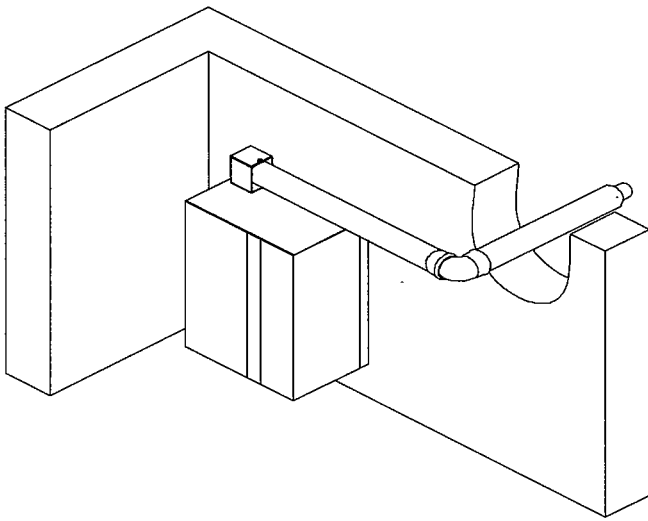

VERTICAL ROOM SEALED FLUE INSTALLATION



### 4.9.3.2 Evacuation Using Horizontal Room Sealed Flue (Type C<sub>13</sub>)

The room sealed flue outlet must be located at least 3 m from any opening window or air ventilation opening. Two balanced flue outlets (from two distinct adjacent boilers) must be at least 1.5 m apart vertically and 0.3 m horizontally. For further limitations on terminal positioning refer to Figure 19 and **BS 5440 Part 1**.

The flue gas exhaust tube must slope towards the outside at 1 cm per metre to avoid accumulation of rain water in the vent-air intake system.

### a) Standard Horizontal Room Sealed Flue

The boiler can be supplied with a standard 1m length flue system (Ref. C035) which can be used to pass through a wall up to 1 metre thick located directly behind the boiler. The flue may also be mounted to the right or to the left of the boiler. For shorter distances, the flue system can be carefully cut to length whilst ensuring that the terminal position and dimension at the wall outlet shown in Figure 17 are maintained. For greater lengths, the flue system can be extended as shown in section b).

Fig. 17

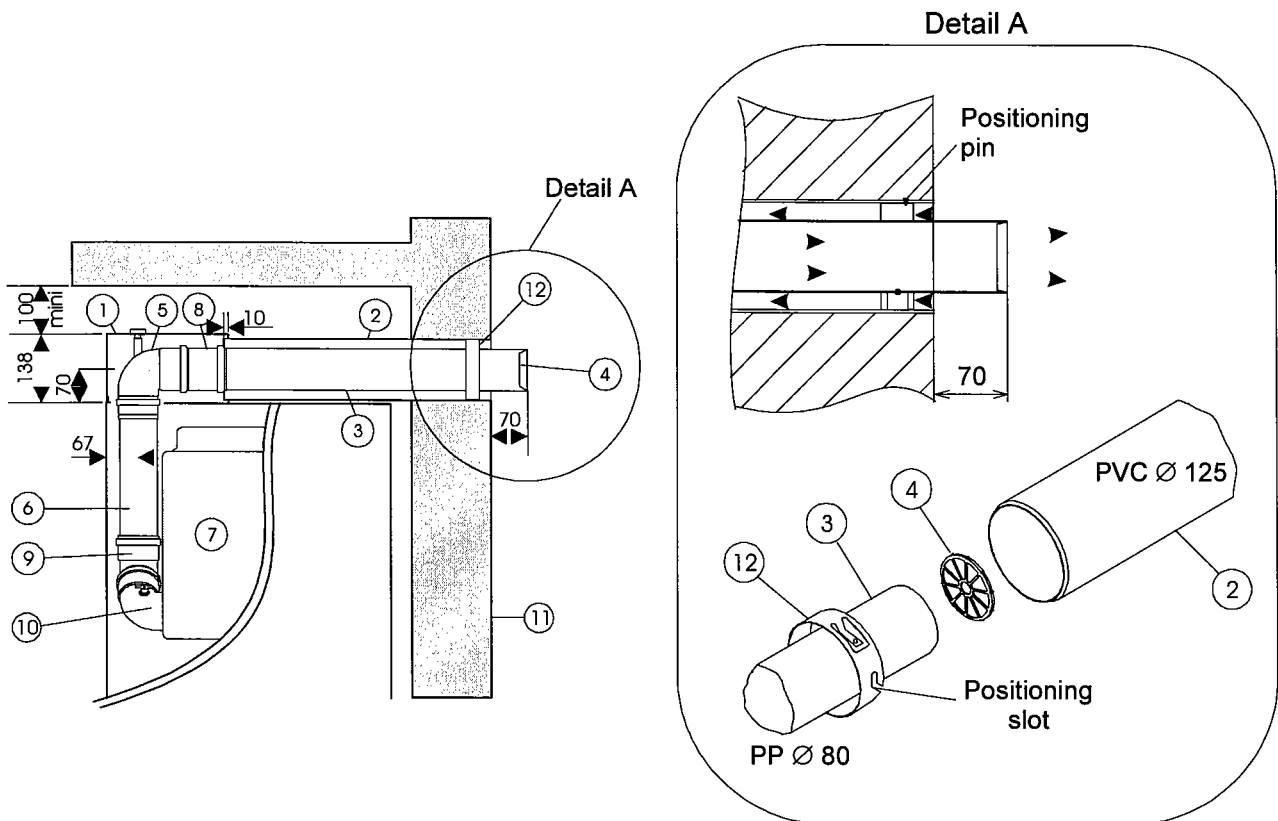

- 1 - Metal adaptor box
- 2 - 125 mm dia. PVC air inlet tube
- 3 - 80 mm dia. PP flue gas tube
- 4 - Non-corrodible terminal
- 5 - 80 mm dia. PP 90 deg. bend
- 6 - 80 mm dia. PP tube length 370 mm

- 7 - Boiler heat exchanger
- 8 - 80 mm dia. PP tube length 140 mm
- 9 - 80 mm dia. PP 45 deg. bend
- 10 - 80 mm dia. PP 90 deg. Bend
- 11 - Outside wall
- 12 - Centering ring

## b) Extended Horizontal Room Sealed Flue

The standard horizontal room sealed flue can be extended by the addition of concentric straight lengths and bends (refer to Figure 18). There is however, a limitation on the total length to which the system can be extended. The maximum equivalent straight length of flue system **must** be limited to **4 metres**. The addition of one 90° bend is equivalent to a straight length of 1 metre and hence only 3 metres maximum

of straight flue are permitted. The following are general examples: -

- 1) 4 metres straight flue. Total - 4 metres.
- 2) 2 metres straight + 1 bend + 1 metre straight. Total - 4 metres.
- 3) 1 metre straight + 1 bend + 2 metres straight. Total - 4 metres.
- 4) 1 metre straight + 2 bends + 1 metre straight. Total - 4 metres.

**Fig. 18**

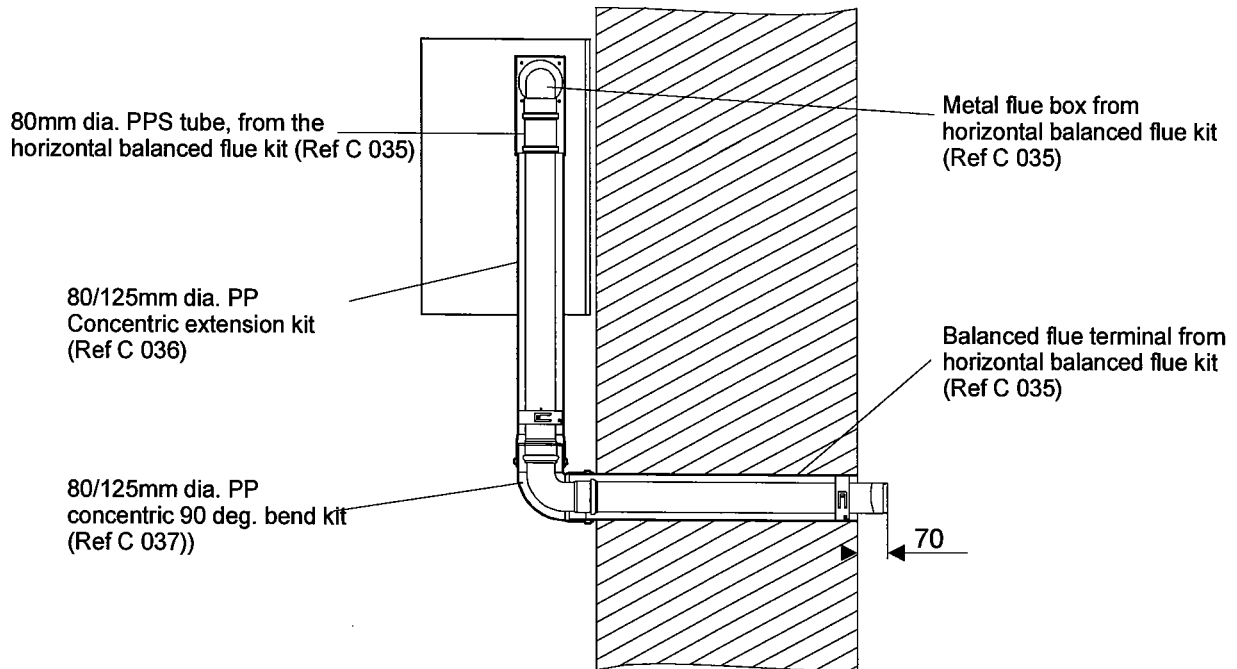

#### 4.9.3.3 Terminal Positions

The flue system must ensure safe and efficient operation of the boiler to which it is attached, protect the combustion process from wind effects and disperse the products of combustion to the external air.

The flue must terminate in a freely exposed position and be so situated as to prevent the products of combustion entering any opening in a building. Details

of terminal positions and other relevant information can be found in **BS 5440 Part 1** and Figure 19 gives general information on the minimum distances a flue terminal must be from commonly occurring features.

**Note:** When the application requires the flue discharge to terminate less than 2 metres above ground level, the use of a terminal guard is required. These can be obtained from most Plumbers and Builders merchants.

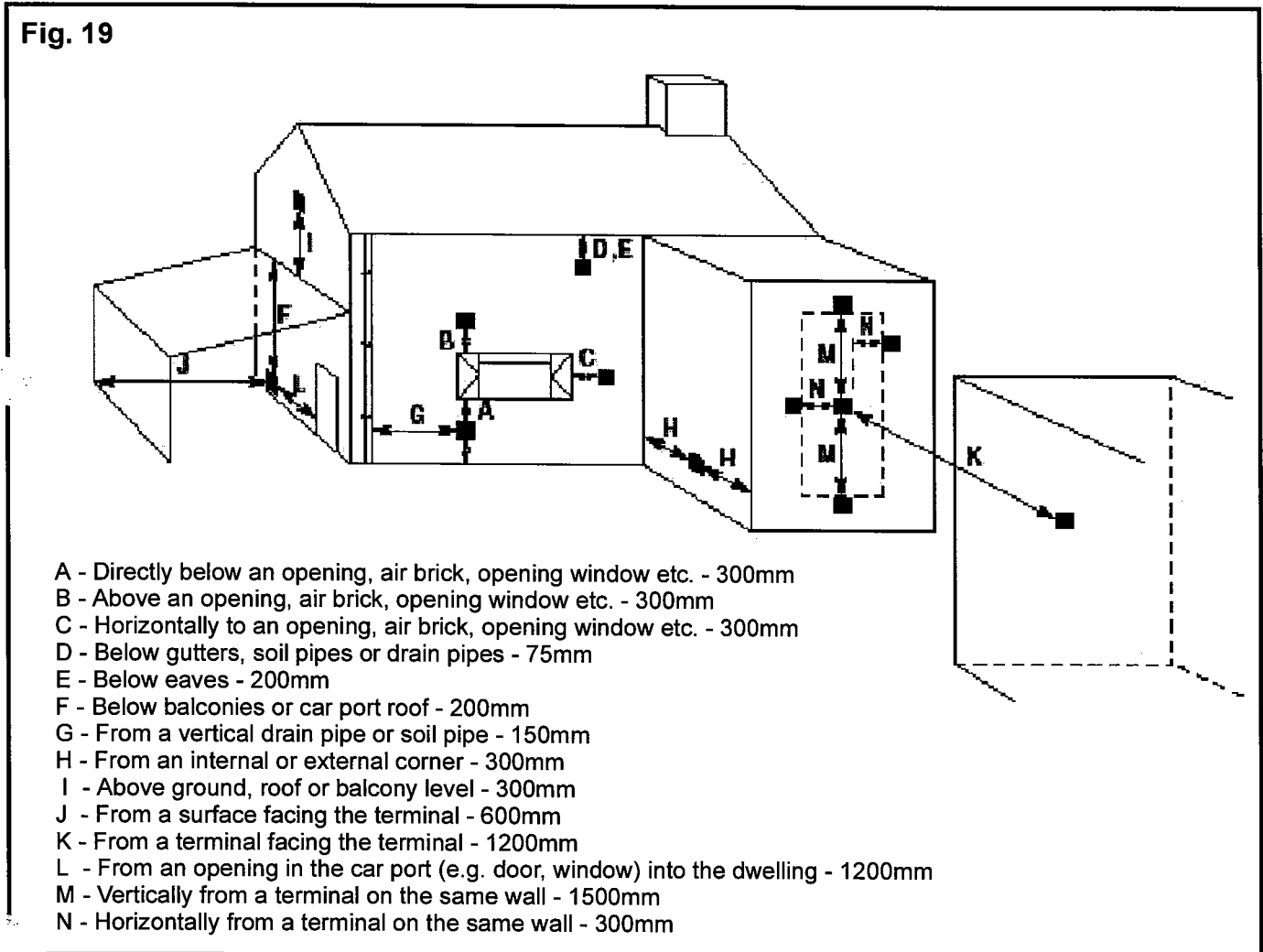

#### 4.10 Gas Supply

##### 4.10.1 Service Pipes

The local gas region must be consulted at the installation planning stage in order to establish the availability of an adequate supply of gas. An existing service pipe must not be used without prior consultation with the local gas region.

##### 4.10.2 Meters

A new gas meter will be connected to the service pipe by the local gas region or their approved contractor. An existing meter should be checked, preferably by the gas region, to ensure that it is adequate to deal with the rate of gas supply required.

##### 4.10.3 Gas Supply Pipes

Supply pipes must be fitted in accordance with **BS 6891** or **IGE/UP/2**. Pipework from the meter to the boiler must be of adequate size and not cause a pressure drop of more than 1 mbar at maximum flow conditions. Do not use pipes of a smaller size than the 1" gas connection on the boiler. During construction, ensure adequate protection is provided to prevent ingress of debris and water into the gas pipework. Blow through the pipework to remove particles before completing final connection to the boiler.

An appropriate approved gas isolating valve, preferably with a union connection downstream to facilitate disconnection, should be fitted local to each boiler.

The complete installation must be purged and tested for soundness as described in **BS 6891, IGE/UP/1 & /1A** as appropriate, prior to commissioning. If high pressure testing of the supply pipework is to be carried out, ensure that the boiler is either not connected or isolated. The maximum allowable test pressure on the gas carrying components of the boiler is 100 mbar.

#### 4.10.4 Boiler House Control Valve

A manual valve for boiler house isolation shall be fitted in the gas supply line. It shall be clearly identified and readily accessible for operation, preferably by an exit.

#### 4.10.5 Boiler Gas System Leak Check

Although the boiler receives a gas leak check prior to leaving the factory, transport and installation may cause disturbance to unions, fittings and assemblies etc. During commissioning, a further test for soundness should be carried out on the boiler gas pipework and components using a manometer or leak detection fluid.

#### 4.11 Electrical Supply

**WARNING: THIS APPLIANCE MUST BE EARTHED  
: ENSURE CORRECT POLARITY OF L & N**

##### 4.11.1 General

Wiring external to the boiler must be installed in accordance with the IEE Regulations and any local regulations which apply. Wiring must be completed in heat resistant 3 - core cable (size: 0.75mm<sup>2</sup> csa). The boiler is supplied suitable for connection to a 230 volt 50 Hz supply solely for use by the boiler. External fuses should be rated at 6A. A mains isolator must be provided adjacent to each boiler in a readily accessible position. The method of connection to the mains electricity supply must facilitate complete electrical isolation of each boiler with a contact separation of at least 3mm on all poles. The boiler can be controlled by an external time clock switching the live supply but this

will act in a similar manner to the boiler on/off switch and some automatic functions of the boiler control system will not operate in off periods, refer to section 2.3. The wiring schematic for the boiler is shown in Figure 20.

#### 4.11.2 Connecting QAC 31 outside sensor and QAA 70 room sensor options

Position the sensors where required and wire back to the boiler using 2 core cable (80m maximum for 1mm<sup>2</sup> csa, 120m maximum for 1.5mm<sup>2</sup> csa). At the boiler, connect the cable to the plug provided (polarity of the wires is not significant) and connect to the boiler terminal rail in the appropriate position, see Figure 20.

### 5.0. COMMISSIONING

#### 5.1 General

Only competent persons registered for working on this type of appliance should attempt the following. Before attempting to commission any boiler, ensure that personnel involved are aware of what action is about to be taken and begin by making the following checks:

- 1) The boiler is correctly adjusted for the gas to be used.
- 2) The gas supply pipework is clear of any loose matter, tested for soundness and purged to **BS 6891, IGE/UP/1 & /1A** as appropriate.
- 3) The flue system is correctly fitted and clear and together with the boiler forms the type of system specified (room sealed, open flue etc.).
- 4) Adequate ventilation for the type of system installed exists in the boiler house or compartment/room.
- 5) The system is fully charged with water and the water conditioner added, ready to receive heat. All necessary valves are open and the system pressure is 1.5 bar. (**Note:** Pressure must not fall below 1 bar).
- 6) The electrical connection is correct with the correct polarity and supply voltage (230 V 50 Hz single phase).
- 7) The condensate discharge is connected to a drain and the trap is filled with water.

## 5.2 Procedure for Initial Lighting

- 1) Open the manual valve on the gas supply.
- 2) Switch the mains electrical supply and the boiler 'on/off' switch to 'on'.

The regulator undergoes a self-check sequence, showing codes L, P, C. 6 and 5 in turn on the digital display. The display then shows 9 and finally 0.

- 3) Ensure any time clock or controls/sensors connected to the boiler are calling for heat. Refer to section 2.2.

Following a wait of a few seconds, the boiler will start an ignition cycle. If the boiler is showing an alarm condition when switched on, press the manual reset button to extinguish the alarm lamp and reset - refer to Figure 3. (If this alarm persists, refer to the list of fault codes, section 3.3).

- 4) Burner adjustment:

**The boiler is factory pre-set for Natural Gas type H (G20)** but the following checks should be carried out with the burner on (refer to Figures 11, 21 and section 2.5 for gas valve test connections).

### a) Gas Inlet Pressure Check

Connect a suitable manometer to the gas inlet pressure test point on the gas valve. Pressure  $P_1$  should read approximately 20 mbar for Natural gas type H (G20).

### b) Burner Gas Pressure Adjustment and Flue Gas Analysis

Connect a suitable manometer to the gas outlet pressure test point  $P_2$  and a combustion analyser to the flue gas test point on the flue discharge to the left of the boiler. Select the regulator 'off' position, refer to section 2.3.9 (the display shows a flashing "7"). Check the  $CO_2/CO$  readings at maximum and minimum input

by adjusting the hot water control to fully clockwise for maximum and fully anticlockwise for minimum. Compare the figures obtained with those in Table 3 and adjust gas flow at the valve (refer to section 2.5), if necessary, to obtain the listed readings. **Note:** The figures in Table 3 are based on a back pressure of zero in the flue. The values of  $P_2$  and  $PL$  may be higher or lower depending on the actual back pressure. **Warning!** Wait for a stable  $CO_2$ ,  $CO$  reading on the analyser before adjusting  $K$ . Switch from minimum to maximum rate several times to ensure that the adjustment has been made correctly. Use an accurately calibrated analyser.

$K$  offsets the curve without changing the slope.

Only adjust  $K$  at the minimum input.

5) To check the correct operation of the flame monitor, break the flame probe circuit by carefully pulling off the connection. The burner should extinguish after approximately 1 second. It will then attempt a re-ignition followed by lockout. Check the flame has been extinguished, reconnect the lead and reset the boiler by pressing the manual reset button.

6) To check the correct operation of the safety thermostats, with the boiler firing, carefully remove one of the connections to either the overheat or flue thermostats. The boiler should immediately shut down. Check the flame has been extinguished, reconnect the lead and reset the boiler by pressing the manual reset button.

7) Check other functions of the controller - refer to section 2.2 and any optional controls fitted - refer to individual instructions.

Table 3

Boiler Settings (factory pre-set to NATURAL GAS type H)				
Data		Unit	Setting/Reading	
			Minimum Input	Maximum Input
Heat output	30/50°C B <sub>23</sub>	kW	10.6	50.5
	30/50°C C <sub>13</sub> /C <sub>33</sub>	kW	10.6	47.8
	60/80°C B <sub>23</sub>	kW	9.5	47.0
	60/80°C C <sub>13</sub> /C <sub>33</sub>	kW	9.5	44.5
Heat input (net)		kW	10.0	50.0
Gas reducer dia.	Natural gas H	mm	7.30	
Air ring dia.	Natural gas H	mm	none	
Gas flow (15°C/1013 mbar)	Natural gas	m <sup>3</sup> /h	1.06	5.29
G20				
Gas Pressure $P_2$ (gas valve-burner)	Natural gas H	mbar	0.40	6.00
Servo-air pressure (PL)		$P_a$	40	610
$CO_2$	Natural gas H	%	7.5 - 8.0	9.0 - 9.5
CO	Natural gas H	ppm	0	20
Nox	Natural gas H	ppm	20	25

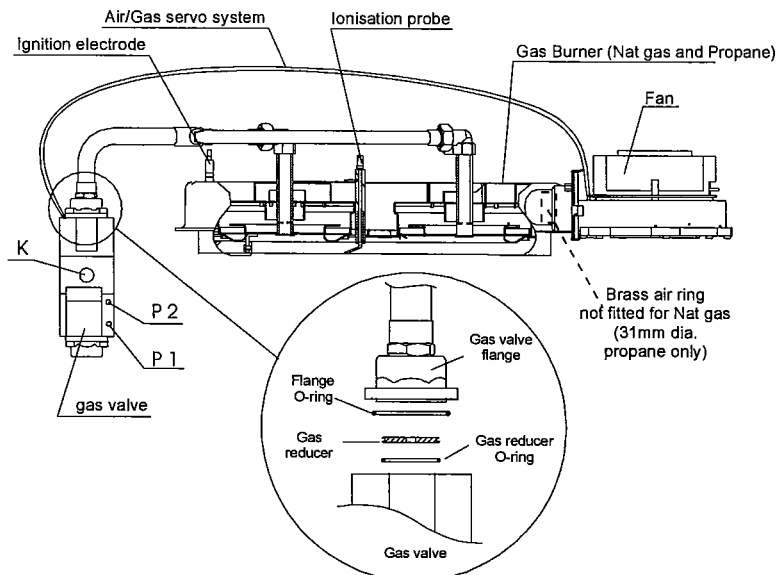
**Fig. 21**

## 6.0 MAINTENANCE

### 6.1 General

A competent person registered for working on the gas appliance should check and ensure that the flue, its support and terminal, the ventilation, safety valve and drain etc. are in a serviceable and working condition and remain compliant with the relevant standards and codes of practice - refer to section 4.1

#### **Regular annual servicing is recommended,**

preferably by a Hamworthy appointed person, to ensure trouble free operation. Although cleaning of flueways may not be necessary on a yearly basis, it is important that all controls and safety features are checked for correct operation.

### 6.2 Annual Service

**Warning: Before servicing the boiler, isolate all electrical supplies and turn off the gas service valve.**

Remove the boiler front casing by removing the 4 cap screws that act as locks on the 4 toggle clamps (2 on top and 2 underneath the casing). Release the 4 toggle clamps and pull the casing forward, release earth cable, and remove.

The main items to be checked are as follows: -

a) Check that the combustion gas circuit, the fan and the burner are clean and that the ignition electrodes, ionisation probe and seals are in good condition. Replace where necessary and set to the dimensions shown in Figure 22.

The burner can be cleaned using a vacuum cleaner, placing the suction tube first on the air inlet, then on the gas inlet (with the burner dismantled).

The heat exchanger can be cleaned by spraying water over the tubes with the burner dismantled. The water is drained away via the condensate trap.

Clean the condensate trap and fill it with water.

b) If not cleaning the heat exchanger, check and clean if necessary, the condensate trap and fill with water.

c) Re assemble and fire the boiler. Carry out a full combustion check and flue gas analysis as detailed in section 5.2.

**Warning:** The combustion products circuit is slightly pressurised. Do not pierce the circuit without subsequently sealing off the hole made.

d) Check the flame monitor by disconnecting the ionisation probe as detailed in section 5.2. 5)

e) Check that the safety thermostat circuit is operating correctly as detailed in section 5.2. 6).

f) Check other functions of the controller and any additional options fitted.

g) When fitting the front casing, reconnect earth cable before engaging the toggle clamps.

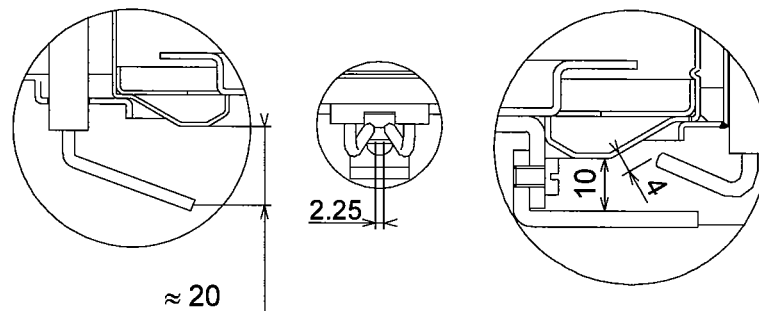
**Fig. 22**

Dimensions in mm

## 7.0 DOMESTIC HOT WATER TANKS

The Cranborne boiler is suitable for connection to a indirect domestic hot water tank sited local to the boiler and with a capacity of between 75 and 300 litres dependant upon the quantity of water required. Hamworthy can supply a range of Powerstock calorifiers suitable for this purpose, to cover the larger hot water requirement. An optional kit can be supplied with the boiler that contains the necessary items to control a hot water tank. These include an actuator and inner valve assembly for the selector valve, the body of which is pre-fitted to every boiler, and the sensor, complete with 4 m of cable, to control the HWS temperature.

### 7.1 Water Connections

The indirect hot water tank should be piped to the boiler as shown in figure 23 and the hot water conversion kit fitted to the boiler. This entails inserting the selector valve cartridge into the body of the valve that is pre-fitted, and adding the pre-formed primary

hot water return pipe from the valve to the boiler casing.

### 7.2 Electrical Connections

The hot water kit contains the electrical actuator for the selector valve and the temperature sensor that should be inserted into an appropriate thermostat pocket on the tank. Both items are complete with cables and plugs that should be inserted into the terminal rail of the boiler. Refer to figure 24 for the correct positions taking care that the 2 way plug on the actuator cable is inserted in terminal 8 and the single connector is inserted in the 3<sup>rd</sup> contact point of terminal 13.

### 7.3 Operating Principle

Once the selector valve and the hot water sensor are installed, the regulator takes hot water production into account and satisfies heating and hot water requirements. Hot water temperature adjustments are made on the boiler or the room sensor, depending on the options fitted - refer to section 2.2.

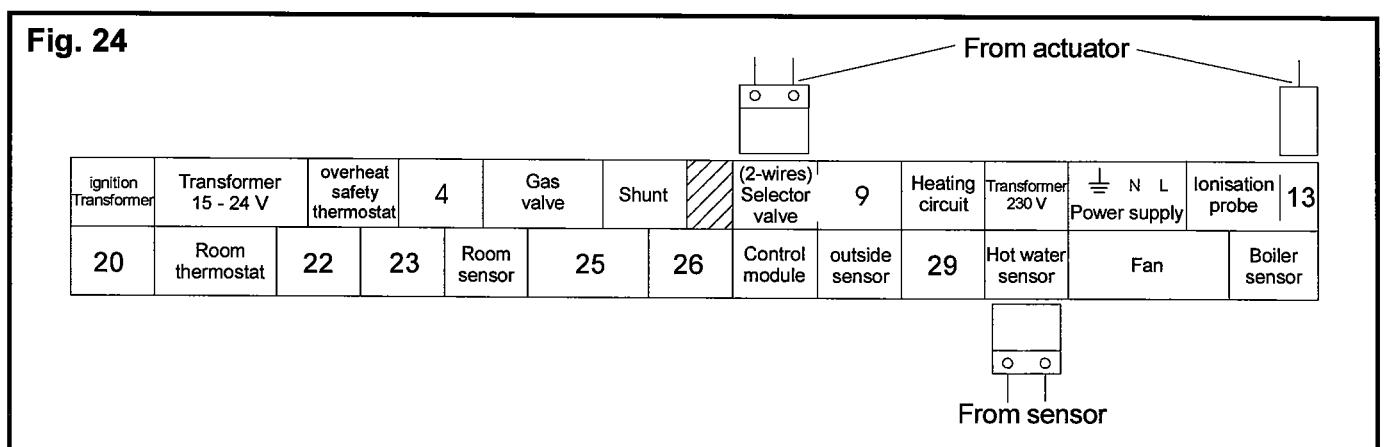
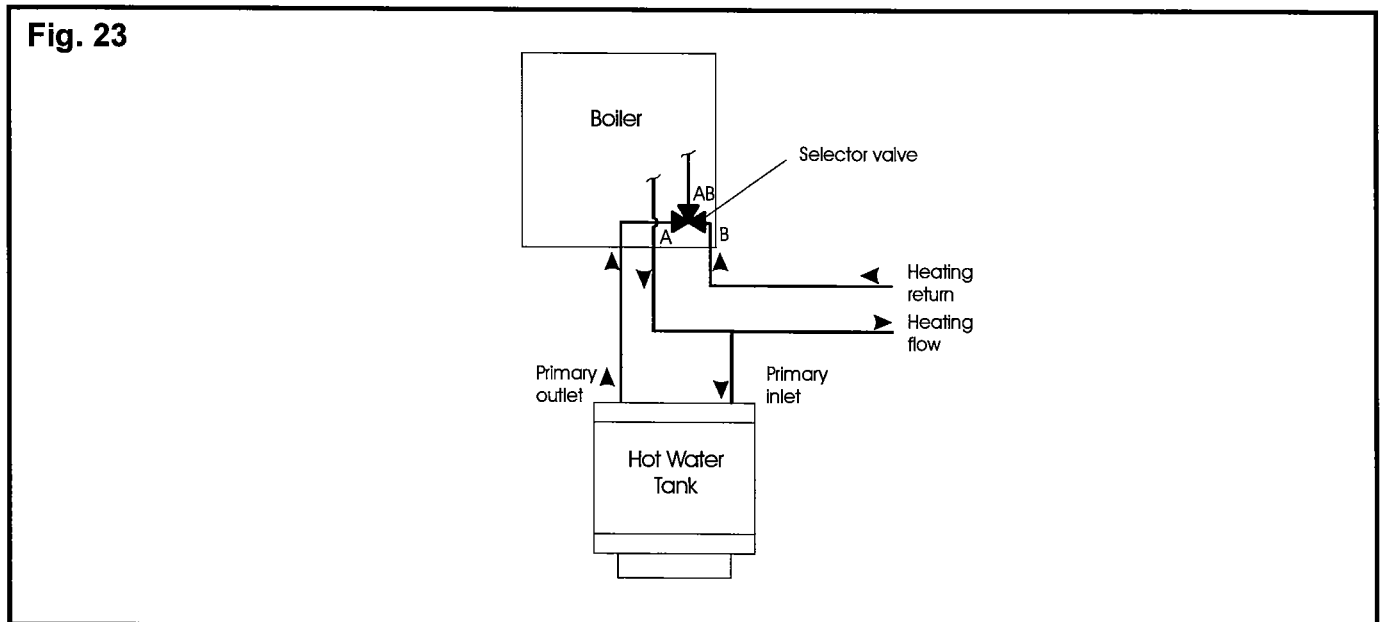

THIS PAGE BLANK