

Technical submittal

Products: **Tyneham CO2 Heat Pump 95kW**

Project:

Customer:

Date:

- ⊙ Made in UK
- ⊙ Monobloc air source heat pumps
- ⊙ Ultra-low GWP due to the use of R744 natural refrigerant
- ⊙ Single unit with the refrigeration cycle contained within the outdoor unit
- ⊙ Inverter controlled compressor to accurately match the heat demand
- ⊙ Highly efficient coefficient of performance (COP)
- ⊙ Quiet noise level as standard, with low noise level models available
- ⊙ Suited to larger installations – cascade systems to achieve higher output
- ⊙ 2 year warranty on parts only
- ⊙ Combine with Hamworthy's boilers for a hybrid heating system

	Tyneham model	Units	95kW
ENERGY	Heat Pump Space Heating [55°C]	ErP rating	-
	Heat Pump Space Heating [55°C]	COP	3
	Heat Pump Space Heating [65°C]	ErP rating	-
	Heat Pump Space Heating [65°C]	COP*	3.4
	Refrigerant		R744
	Refrigerant Charge	(kg)	6.5
HEATING	Global Warming Potential	GWP	1
	Heating (A7/W65)	Capacity (kW)	95
	Heating (A7/W65)	Power Input (kW)	25
	Heating (A7/W65)	SCOP	3.5
	Max Flow Temperature	Max [°C]	70
SOUND	Air Temperature Range	Min/Max [°C]	(-15 no max)
	Sound Data Outdoor unit	Power Level dB(A)**	75
CONNECTIONS	Sound Data Outdoor unit	Pressure Level at 10m dB (A)***	44
	Pipework Connection Sizes	Heating Flow (mm)	35
ELECTRICS	Pipework Connection Sizes	Heating Return (mm)	35
	Electrical Supply	(v)	400
	Phase		Three
	Max Running Current	(amp)	67.55
DIMENSIONS	Fuse Rating	(amp)	80
	Width	(mm)	3051
	Depth	(mm)	1160
	Height	(mm)	1853
	Weight	(kg)	1260



Every effort has been taken to ensure the details are accurate. Hamworthy Heating does not, however, guarantee the accuracy or completeness of any information nor does it accept liability for any errors or omissions in the information. Hamworthy Heating reserves the right to make changes and improvements which may necessitate alteration to product specification without prior notice.

Technical submittal

Products: **Tyneham CO2 Heat Pump 95kW**

Project:

Customer:

Date:

Dimensions

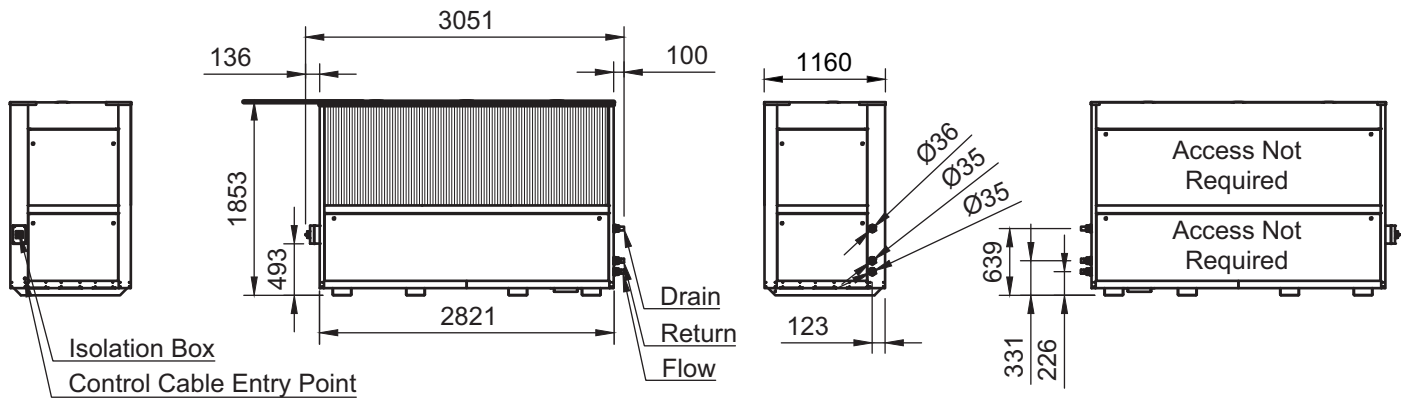

Note: All dimensions in mm unless otherwise stated.

Minimum installation clearances:

Front: 1000mm

Rear: 0mm (Designed to back up to a wall)

Left/Right: 1000mm

Accessories and options:

	Included	Optional
Master controller		•
DHW controller		•
Flexible hoses		•
Burst disc pressure relief kit		•
Exogel antifreeze kit		•
Anti-corrosion coating for installations close to the sea (special order)		•

Terms and conditions apply:

Tyneham CO2 & CO2Q models all represent the output at Air 7°C & Water 65°C.

* Coefficient of Performance (COP) rated at EN14825 test conditions Water 65°C / Air 7°C.

** The sound power has been established in general accordance with BS EN ISO 3740: 2019 with a survey grade accuracy (sR0) = 4 dB.

*** Sound pressure level at 10m determined in accordance with Annex D of BS EN ISO 13487(TC): 2019.

Every effort has been taken to ensure the details are accurate. Hamworthy Heating does not, however, guarantee the accuracy or completeness of any information nor does it accept liability for any errors or omissions in the information. Hamworthy Heating reserves the right to make changes and improvements which may necessitate alteration to product specification without prior notice.