

AIR CONDITIONER

Simultaneous multi

DESIGN & TECHNICAL MANUAL

INDOOR

AUHG18LVLB × 4
AUHG22LVLA × 4
AUHG24LVLA × 3



AUHG30LRLE × 3
AUHG36LRLE × 2
AUHG45LRLA × 2



ARHG18LLTB × 4



ARHG22LMLA × 4
ARHG24LMLA × 3
ARHG30LMLE × 3
ARHG36LMLE × 2
ARHG45LMLA × 2



ABHG18LVTB × 4
ABHG22LVTA × 4
ABHG24LVTA × 3



ABHG30LRTE × 3
ABHG36LRTE × 2
ABHG45LRTA × 2

OUTDOOR

AOHG72LRLA
AOHG90LRLA

FUJITSU GENERAL LIMITED

Notices:

- Product specifications and design are subject to change without notice for future improvement.
- For further details, please check with our authorized dealer.

CONTENTS

Part 1. INDOOR UNITS1

1. Model lineup	2
2. Specifications	3
2-1. Compact cassette type	3
2-2. Cassette type	4
2-3. Slim duct type	5
2-4. Duct type.....	6
2-5. Floor/Ceiling type	8
2-6. Ceiling type	9
3. Dimensions	10
3-1. Compact cassette type	10
3-2. Cassette type	12
3-3. Slim duct type	14
3-4. Duct type.....	17
3-5. Floor/Ceiling type	19
3-6. Ceiling type	21
4. Wiring diagrams	23
4-1. Compact cassette type	23
4-2. Cassette type	24
4-3. Slim duct type	25
4-4. Duct type.....	26
4-5. Floor/Ceiling type	28
4-6. Ceiling type	29
5. Air velocity and temperature distributions	30
5-1. Compact cassette type	30
5-2. Cassette type	36
5-3. Slim duct type	42
5-4. Floor/Ceiling type	44
5-5. Ceiling type	50
6. Fan performance	53
6-1. Slim duct type	53
6-2. Duct type.....	55
7. Airflow	95
7-1. Compact cassette type	95
7-2. Cassette type	101
7-3. Slim duct type	107
7-4. Duct type.....	108
7-5. Floor/Ceiling type	113
7-6. Ceiling type	116
8. Noise level curve	119
8-1. Compact cassette type	119

CONTENTS (continued)

8-2. Cassette type	121
8-3. Slim duct type	123
8-4. Duct type.....	124
8-5. Floor/Ceiling type	127
8-6. Ceiling type	129
8-7. Sound level check point	131
9. Electrical characteristics	135
10. Safety devices	136
11. Accessories	137
11-1.Compact cassette type	137
11-2.Cassette type	138
11-3.Slim duct type	139
11-4.Duct type.....	140
11-5.Floor/Ceiling type	141
11-6.Ceiling type	142

CONTENTS (continued)

Part 2. OUTDOOR UNIT	143
1. Specifications	144
2. Dimensions	145
2-1. Models: AOHG72LRLA and AOHG90LRLA	145
3. Installation space	146
3-1. Models: AOHG72LRLA and AOHG90LRLA	146
4. Refrigerant circuit	149
4-1. Models: AOHG72LRLA and AOHG90LRLA	149
5. Wiring diagrams	152
5-1. Models: AOHG72LRLA and AOHG90LRLA	152
6. Capacity table	153
6-1. Model: AOHG72LRLA.....	153
6-2. Model: AOHG90LRLA.....	159
7. Capacity compensation rate for pipe length and height difference	165
7-1. Model: AOHG72LRLA.....	165
7-2. Model: AOHG90LRLA.....	166
8. Airflow	167
8-1. Model: AOHG72LRLA.....	167
8-2. Model: AOHG90LRLA.....	167
9. Operation noise (sound pressure)	168
9-1. Noise level curve.....	168
9-2. Sound level check point	169
10. Electrical characteristics	170
11. Safety devices	171
12. Accessories	172

CONTENTS (continued)

Part 3. SYSTEM DESIGN173

1. Installation precautions	174
1-1. Indoor unit installation precautions.....	174
1-2. Outdoor unit installation precautions	178
2. Pipe design	179
2-1. Important items when using refrigerant (R410A).....	179
2-2. Piping limitation.....	180
2-3. Pipe size	187
2-4. Selection of pipe heat insulating material.....	189
2-5. Additional charge calculation	190
3. Pipe installation.....	195
3-1. Caution of piping	195
3-2. Piping to outdoor unit.....	197
3-3. Pipe connection	198
3-4. Branch pipes	202
4. Wiring design	209
4-1. Precaution for electrical wiring	209
4-2. Power supply cable wiring.....	211
4-3. Control patterns	217
5. System setting.....	221
5-1. Indoor unit setting	221
6. External input and output.....	225
6-1. Indoor unit.....	225
6-2. Outdoor unit	232
7. Remote controller	236
7-1. Wireless remote controller (AR-RAH2E/AR-RAH1E).....	236
7-2. IR receiver kit with Wireless remote controller (UTY-LRHGA2: Optional part).....	239
7-3. IR receiver kit with Wireless remote controller (UTY-LRHGM: Optional part)	242
7-4. Wired remote controller (UTY-RNNGM)	245
7-5. Wired remote controller (UTY-RVNGM: Optional part)	249
7-6. Simple remote controller (UTY-RSNGM: Optional part).....	257
8. Function settings	261
8-1. Indoor unit (setting by DIP switch and jumper wire)	261
8-2. Indoor unit (setting by wireless remote controller).....	263
8-3. Indoor unit (setting by wired remote controller)	269
8-4. Indoor unit (setting by simple remote controller)	275
8-5. Outdoor unit	279
8-6. Function details.....	284
8-7. Wired remote controller (UTY-RNNGM)	290
8-8. Wired remote controller (UTY-RVNGM).....	292
8-9. Simple remote controller (UTY-RSNGM)	293

CONTENTS (continued)

9. Check and test.....	294
9-1. Test run.....	294
9-2. Error code	296
9-3. Pump down.....	297
10. Optional parts installation	299
10-1.Drain pump unit for duct type (UTZ-PX1NBA)	299
10-2.Drain pump unit for ceiling type (UTR-DPB24T)	302
10-3.Fresh air intake kit for cassette type (UTZ-VXRA)	303
10-4.Fresh air intake kit for compact cassette type (UTZ-VXAA).....	313
10-5.Auto louver grille kit (UTD-GXTB-W)	322

CONTENTS (continued)

Part 4. OPTIONAL PARTS.....325

1. Branch pipes	326
1-1. Model: UTP-SX272A.....	326
1-2. Model: UTP-SX372A.....	327
1-3. Model: UTP-SX236A.....	328
1-4. Model: UTP-SX254A.....	329
2. Controllers	330
2-1. Lineup	330
2-2. Parts	331
3. Cassette grille.....	332
3-1. Lineup	332
3-2. Parts	332
4. Others.....	333
4-1. Lineup	333
4-2. Parts	334

Part 1. INDOOR UNITS

COMPACT CASSETTE TYPE:

AUHG18LVLB
AUHG22LVLA
AUHG24LVLA

CASSETTE TYPE:

AUHG30LRLE
AUHG36LRLE
AUHG45LRLA

SLIM DUCT TYPE:

ARHG18LLTB

DUCT TYPE:

ARHG22LMLA
ARHG24LMLA
ARHG30LMLE
ARHG36LMLE
ARHG45LMLA









FLOOR/CEILING TYPE:

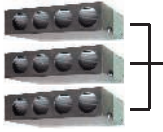
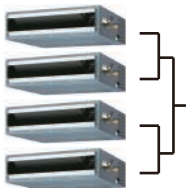





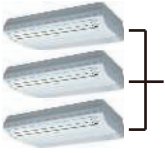

ABHG18LVTB
ABHG22LVTA
ABHG24LVTA

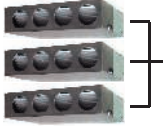
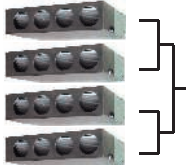
CEILING TYPE:

ABHG30LRTE
ABHG36LRTE
ABHG45LRTA

1. Model lineup

Indoor unit			Outdoor unit
Twin	Triple	Double twin	
36 kBtu/h × 2	24 kBtu/h × 3	18 kBtu/h × 4	
ARHG36LMLE 	ARHG24MLA 	ARHG18LLTB 	AOHG72LRLA 
AUHG36LRLE 	AUHG24LVLA 	AUHG18LVLB 	
ABHG36LRTE 	ABHG24LVTA 	ABHG18LVTB 	

Indoor unit			Outdoor unit
Twin	Triple	Double twin	
45 kBtu/h × 2	30 kBtu/h × 3	22 kBtu/h × 4	
ARHG45MLA 	ARHG30LMLE 	ARHG22LMLA 	AOHG90LRLA 
AUHG45LRLA 	AUHG30LRLE 	AUHG22LVLA 	
ABHG45LRTE 	ABHG30LRTE 	ABHG22LVTA 	

2. Specifications

2-1. Compact cassette type

Model name				AUHG18LVLB	AUHG22LVLA	AUHG24LVLA
Power supply				1Ø 230 V ~50 Hz		
Available voltage range				198—264 V		
Fan	Airflow rate	Cooling	HIGH	m ³ /h	680	930
			MED		580	830
			LOW		490	600
			QUIET		410	450
		Heating	HIGH		800	930
			MED		680	860
			LOW		580	700
			QUIET		450	530
	Type × Q'ty		Turbo fan × 1			
	Motor output		W			
		54				
Sound pressure level *	Cooling	HIGH	dB (A)	38	49	
		MED		34	44	
		LOW		30	36	
		QUIET		26	30	
	Heating	HIGH		43	49	
		MED		38	45	
		LOW		34	40	
		QUIET		30	33	
Heat exchanger type	Dimensions (H × W × D)		mm	210 × 1,310 × 13.3 210 × 1,250 × 13.3	210 × 1,375 × 13.3 210 × 1,310 × 13.3 210 × 1,250 × 13.3	
	Fin pitch		mm	1.20	1.45	
	Rows × Stages			2 × 10	3 × 10	
	Pipe type			Copper tube		
	Fin type			Aluminum		
Dimensions (H × W × D)	Net		mm	245 × 570 × 570		
	Gross			265 × 730 × 625		
Weight	Net		kg	15	16	
	Gross			18	19	
Connection pipe	Size	Liquid	mm (in)	Ø6.35 (Ø1/4)		
		Gas		Ø12.70 (Ø1/2)	Ø15.88 (Ø5/8)	
	Method			Flare		
Operation range	Cooling	°C	18 to 32			
		%RH	80 or less			
	Heating	°C	16 to 30			
Drain hose	Material		Hard PVC			
	Size		mm			
Cassette grille (Option)	Model name			UTG-UFGD-W		
	Material			PS		
	Color			White (Approximate color of Munsell N 9.25/)		
	Dimensions (H × W × D)	Net	mm	49 × 700 × 700		
				Gross	120 × 765 × 755	
	Weight	Net	kg	2.6		
		Gross		4.5		
Remote controller type				Wireless (Wired [option])		
NOTES:						
<ul style="list-style-type: none"> The protective function might work when using it outside the operation range. *: Sound pressure level: <ul style="list-style-type: none"> These are the measured values in the manufacturer's anechoic chamber. Because of the surrounding sound environment, the sound levels measured in actual installation conditions might be higher than the specified values here. 						

2-2. Cassette type

Model name				AUHG30LRLE	AUHG36LRLE	AUHG45LRLA
Power supply				1Ø 230 V ~50 Hz		
Available voltage range				198—264 V		
Fan	Airflow rate	Cooling	HIGH	1,600	1,800	1,900
			MED	1,400	1,400	1,640
			LOW	1,270	1,270	1,460
			QUIET	1,150	1,150	1,250
		Heating	HIGH	1,600	1,800	1,900
			MED	1,400	1,400	1,640
			LOW	1,270	1,270	1,460
			QUIET	1,150	1,150	1,250
	Type × Q'ty		Turbo fan × 1			
	Motor output		W			
Sound pressure level *	Cooling	HIGH	40	43	46	
		MED	38	38	42	
		LOW	36	36	40	
		QUIET	32	32	36	
	Heating	HIGH	40	43	46	
		MED	38	38	42	
		LOW	36	36	40	
		QUIET	32	32	36	
Heat exchanger type	Dimensions (H × W × D)		mm	252 × 2030 × 26.6 252 × 2093 × 26.6		252 × 2,021 × 13.3 252 × 2,087 × 13.3 252 × 2,153 × 13.3
	Fin pitch		mm	1.20		1.30
	Rows × Stages		2 × 12			
	Pipe type		Copper tube			
	Fin type		Aluminum			
Dimensions (H × W × D)	Net		mm	288 × 840 × 840		
	Gross		360 × 960 × 985			
Weight	Net		kg	26		
	Gross		31			
Connection pipe	Size	Liquid	mm (in)	Ø9.52 (Ø3/8)		
		Gas	Ø15.88 (Ø5/8)			
	Method		Flare			
Operation range	Cooling	°C		18 to 32		
		%RH		80 or less		
Drain hose	Material	°C		16 to 30		
		Hard PVC		Ø 25 (I.D.), Ø 32 (O.D.)		
Cassette grille (option)	Model name		UTG-UGGA-W			
	Material		PS			
	Color		White (Approximate color of Munsell N 9.25/)			
	Dimensions (H × W × D)	Net	mm	50 × 950 × 950		
		Gross	115 × 1,020 × 1,000			
	Weight	Net	kg	5.5		
		Gross	8.6			
	Remote controller type		Wired			

NOTES:

- The protective function might work when using it outside the operation range.
- *: Sound pressure level:
 - These are the measured values in the manufacturer's anechoic chamber.
 - Because of the surrounding sound environment, the sound levels measured in actual installation conditions might be higher than the specified values here.

2-3. Slim duct type

Model name				ARHG18LLTB		
Power supply				1Ø 230 V ~50 Hz		
Available voltage range				198—264 V		
Fan	Airflow rate	Cooling	HIGH	m ³ /h	940	
			MED		880	
			LOW		820	
			QUIET		750	
		Heating	HIGH		940	
			MED		880	
			LOW		820	
			QUIET		750	
	Type × Q'ty				Sirocco fan × 3	
	Motor output				W	
Recommended static pressure				Pa		
				0 to 90		
Sound pressure level *	Cooling		HIGH	dB (A)	32	
			MED		31	
			LOW		30	
			QUIET		29	
	Heating		HIGH		33	
			MED		32	
			LOW		31	
			QUIET		29	
Heat exchanger type	Dimensions (H × W × D)		mm	294 × 700 × 39.9		
	Fin pitch		mm	1.30		
	Rows × Stages			3 × 14		
	Pipe type			Copper tube		
	Fin type			Aluminum		
Enclosure	Material			Steel sheet		
	Color			—		
Dimensions (H × W × D)	Net		mm	198 × 900 × 620		
	Gross			274 × 1,168 × 772		
Weight	Net		kg	23		
	Gross			27		
Connection pipe	Size	Liquid	mm (in)	Ø6.35 (Ø1/4)		
		Gas		Ø12.70 (Ø1/2)		
	Method			Flare		
Operation range	Cooling		°C	18 to 32		
			%RH	80 or less		
	Heating		°C	16 to 30		
Drain hose	Material		Hard PVC			
	Size		mm	Ø 25 (I.D.), Ø 32 (O.D.)		
Remote controller type				Wired (Wireless [option])		

NOTES:

- Values mentioned in the table are based on the following conditions:
 - Static pressure: 25 Pa
- The protective function might work when using it outside the operation range.
- *: Sound pressure level:
 - These are the measured values in the manufacturer's anechoic chamber.
 - Because of the surrounding sound environment, the sound levels measured in actual installation conditions might be higher than the specified values here.

2-4. Duct type

Model name				ARHG22LMLA	ARHG24LMLA
Power supply				1Ø 230 V ~50 Hz	
Available voltage range				198—264 V	
Fan	Airflow rate	Cooling	HIGH	m ³ /h	1,100
			MED		910
			LOW		750
			QUIET		580
		Heating	HIGH		1,100
			MED		910
			LOW		750
			QUIET		580
	Type × Q'ty		Sirocco fan × 2		
	Motor output		W		
Recommended static pressure		Pa			
		30 to 150			
Sound pressure level *	Cooling	HIGH	dB (A)	31	
		MED		29	
		LOW		27	
		QUIET		25	
	Heating	HIGH		31	
		MED		29	
		LOW		27	
		QUIET		25	
Heat exchanger type	Dimensions (H × W × D)		mm	294 × 1,000 × 39.9	
	Fin pitch		mm	1.40	
	Rows × Stages			3 × 14	
	Pipe type			Copper	
	Fin type			Aluminum	
Enclosure	Material			Steel sheet	
	Color			—	
Dimensions (H × W × D)	Net		mm	270 × 1,135 × 700	
	Gross			300 × 1,320 × 790	
Weight	Net		kg	38	
	Gross			44	
Connection pipe	Size	Liquid	mm (in)	Ø 6.35 (Ø 1/4)	
		Gas		Ø 15.88 (Ø 5/8)	
	Method		Flare		
Operation range	Cooling	°C		18 to 32	
		%RH		80 or less	
	Heating	°C		16 to 30	
Drain hose	Material			Steel	
	Size		mm	Ø35.7 (I.D.), Ø38.1 (O.D.)	
Remote controller type				Wired (Wireless [option])	

NOTES:

- Values mentioned in the table are based on the following conditions:
 - Static pressure: 35 Pa
- The protective function might work when using it outside the operation range.
- *: Sound pressure level:
 - These are the measured values in the manufacturer's anechoic chamber.
 - Because of the surrounding sound environment, the sound levels measured in actual installation conditions might be higher than the specified values here.

Model name				ARHG30LMLE	ARHG36LMLE	ARHG45LMLA
Power supply				1Ø 230 V ~50 Hz		
Available voltage range				198—264 V		
Fan	Airflow rate	Cooling	HIGH	m ³ /h	1,900	2,100
			MED		1,620	1,750
			LOW		1,270	1,350
			QUIET		980	1,070
		Heating	HIGH		2,100	2,100
			MED		1,620	1,750
			LOW		1,270	1,350
			QUIET		980	1,070
	Type × Q'ty		Sirocco fan × 2			
	Motor output		197			
Recommended static pressure			Pa	30 to 150		
Sound pressure level *	Cooling	HIGH	dB (A)	39	42	
		MED		35	38	
		LOW		30	32	
		QUIET		26	28	
	Heating	HIGH		42	42	
		MED		35	38	
		LOW		30	32	
		QUIET		26	28	
Heat exchanger type	Dimensions (H × W × D)		mm	294 × 1,000 × 39.9	294 × 1,000 × 53.2	
	Fin pitch		mm	1.40		
	Rows × Stages			3 × 14	4 × 14	
	Pipe type			Copper		
	Fin type			Aluminum Steel sheet		
Enclosure	Material					
	Color		—			
Dimensions (H × W × D)	Net		mm	270 × 1,135 × 700		
	Gross			300 × 1,320 × 790		
Weight	Net		kg	40		
	Gross			47		
Connection pipe	Size	Liquid	mm (in)	Ø 9.52 (Ø 3/8)		
		Gas		Ø 15.88 (Ø 5/8)		
	Method			Flare		
Operation range	Cooling		°C	18 to 32		
			%RH	80 or less		
	Heating		°C	16 to 30		
Drain hose	Material		Steel			
	Size		mm	Ø35.7 (I.D.), Ø38.1 (O.D.)		
Remote controller type				Wired (Wireless [option])		
NOTES:						
<ul style="list-style-type: none"> • Values mentioned in the table are based on the following conditions: <ul style="list-style-type: none"> – Static pressure: 47 Pa (30, 36 model), 60 Pa (45 model) • The protective function might work when using it outside the operation range. • *: Sound pressure level: <ul style="list-style-type: none"> – These are the measured values in the manufacturer's anechoic chamber. – Because of the surrounding sound environment, the sound levels measured in actual installation conditions might be higher than the specified values here. 						

2-5. Floor/Ceiling type

Model name				ABHG18LVTB	ABHG22LVTA	ABHG24LVTA		
Power supply				1Ø 230 V ~50 Hz				
Available voltage range				198—264 V				
Fan	Airflow rate	Cooling	HIGH	m ³ /h	780	980		
			MED		700	820		
			LOW		560	680		
			QUIET		500	540		
		Heating	HIGH		780	980		
			MED		700	820		
			LOW		560	680		
			QUIET		500	540		
	Type × Q'ty				Sirocco fan × 2			
	Motor output				W			
				80				
Sound pressure level *	Cooling	HIGH	HIGH	dB (A)	44 (Floor console) 43 (Under ceiling)	49 (Floor console) 48 (Under ceiling)		
			MED		41 (Floor console) 40 (Under ceiling)	45 (Floor console) 44 (Under ceiling)		
			LOW		35 (Floor console) 34 (Under ceiling)	41 (Floor console) 40 (Under ceiling)		
		QUIET	32 (Floor console) 31 (Under ceiling)		36 (Floor console) 35 (Under ceiling)			
			Heating		HIGH	44 (Floor console) 43 (Under ceiling)	49 (Floor console) 48 (Under ceiling)	
					MED	41 (Floor console) 40 (Under ceiling)	45 (Floor console) 44 (Under ceiling)	
	LOW	35 (Floor console) 34 (Under ceiling)			41 (Floor console) 40 (Under ceiling)			
	QUIET	32 (Floor console) 31 (Under ceiling)	36 (Floor console) 35 (Under ceiling)					
		Heat exchanger type			Dimensions (H × W × D)	mm	252 × 800 × 39.9	252 × 800 × 53.2
					Fin pitch	mm	1.30	1.45
			Rows × Stages			3 × 12	4 × 12	
			Pipe type			Copper tube		
		Fin type		Aluminum				
Enclosure	Material			ABS				
	Color			White (Approximate color of Munsell N 9.25/)				
Dimensions (H × W × D)	Net		mm	199 × 990 × 655				
	Gross			320 × 1,150 × 790				
Weight	Net		kg	27				
	Gross			36				
Connection pipe	Size	Liquid	mm (in)	Ø6.35 (Ø1/4)				
		Gas		Ø12.70 (Ø1/2)	Ø15.88 (Ø5/8)			
	Method				Flare			
Drain hose	Material			Hard PVC				
	Size		mm	Ø25 (I.D.), Ø32 (O.D.)				
Operation range	Cooling		°C	18 to 32				
			%RH	80 or less				
	Heating		°C	16 to 30				
Remote controller type				Wireless (Wired [option])				

NOTES:

- The protective function might work when using it outside the operation range.
- *Sound pressure level:
 - Measured values in manufacturer's anechoic chamber.
 - Because of the surrounding sound environment, the sound levels measured in actual installation conditions might be higher than the specified values here.

2-6. Ceiling type

Model name				ABHG30LRTE	ABHG36LRTE	ABHG45LRTE
Power supply				1Ø 230 V ~50 Hz		
Available voltage range				198—264 V		
Fan	Airflow rate	Cooling	HIGH	1,660	1,900	2,100
			MED	1,500	1,500	1,700
			LOW	1,200	1,200	1,400
			QUIET	1,000	1,000	1,100
		Heating	HIGH	1,660	1,900	2,100
			MED	1,500	1,500	1,700
			LOW	1,200	1,200	1,400
			QUIET	1,000	1,000	1,100
	Type × Q'ty		Sirocco fan × 4			
	Motor output		W			
		120				
Sound pressure level *	Cooling	HIGH	45	47	49	
		MED	43	43	45	
		LOW	37	37	39	
		QUIET	32	32	34	
	Heating	HIGH	45	47	49	
		MED	43	43	45	
		LOW	37	37	39	
		QUIET	32	32	34	
Heat exchanger type	Dimensions (H × W × D)		mm	252 × 1,350 × 39.9		
	Fin pitch		mm	1.45		
	Rows × Stages			3 × 12		
	Pipe type			Copper tube		
	Fin type			Aluminum		
Enclosure	Material		ABS			
	Color		White (Approximate color of Munsell N 9.25/)			
Dimensions (H × W × D)	Net	mm	240 × 1,660 × 700			
	Gross		318 × 1,800 × 790		318 × 1,800 × 795	
Weight	Net	kg	46			
	Gross		58			
Connection pipe	Size	Liquid	Ø9.52 (Ø3/8)			
		Gas	Ø15.88 (Ø5/8)			
	Method	Flare				
Drain hose	Material		ABS			
	Size		mm	Ø22.0 (I.D.), Ø25.6 (O.D.)		
Operation range	Cooling	°C	18 to 32			
		%RH	80 or less			
Remote controller type	Heating	°C	16 to 30			
				Wireless		
NOTES:						
<ul style="list-style-type: none"> • The protective function might work when using it outside the operation range. • *Sound pressure level: <ul style="list-style-type: none"> – Measured values in manufacturer's anechoic chamber. – Because of the surrounding sound environment, the sound levels measured in actual installation conditions might be higher than the specified values here. 						

3. Dimensions

3-1. Compact cassette type

■ Models: AUHG18LVLB, AUHG22LVLA, and AUHG24LVLA

Unit: mm

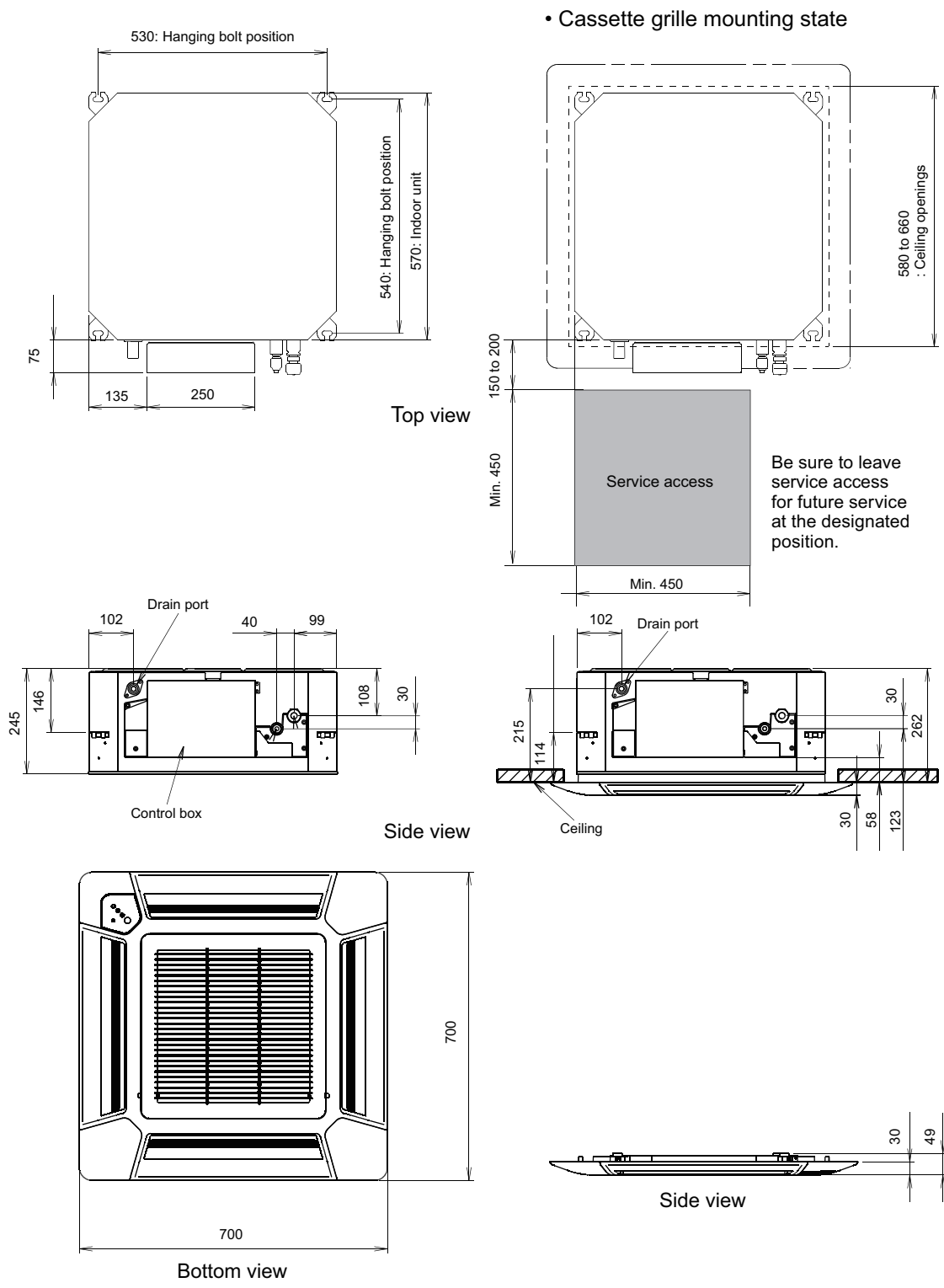

● Installation space requirement

Unit: mm

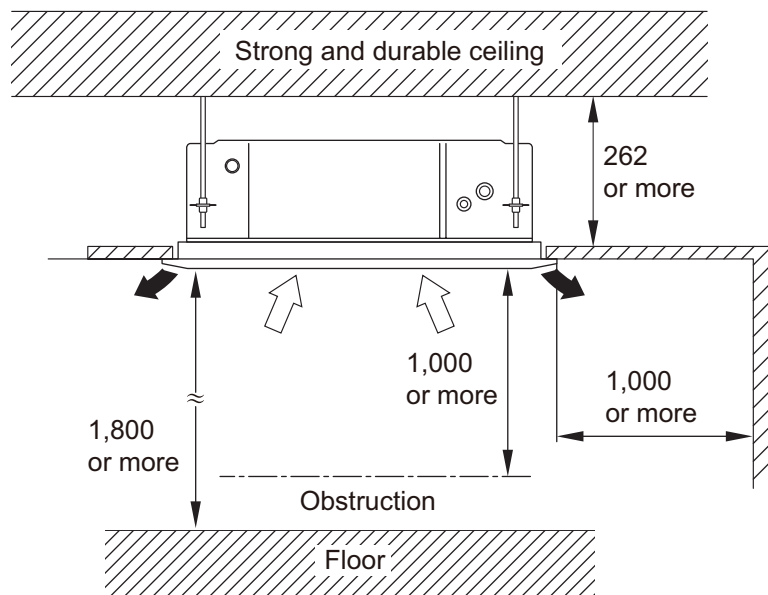

Maximum height from floor to ceiling (Unit: mm)	
Standard	2,700
High ceiling	3,000

3-way direction setting:

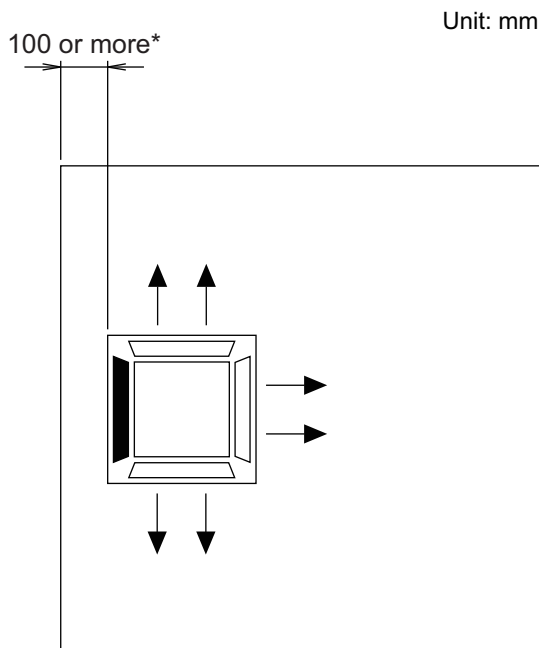

NOTES:

- To set "3-direction", optional Air outlet shutter plate (UTR-YDZB) must be installed, and the "outlet-direction" need to be switched to "3-way" by remote controller.
*When installing the indoor unit, be careful about the maintenance space.
- In 3-way outlet mode, changing of ceiling height setting by function setting 20 is prohibited. (Ceiling height setting [function setting 20] is allowed to be changed only in 4-way outlet mode.)

3-2. Cassette type

■ Models: AUHG30LRLE, AUHG36LRLE, and AUHG45LRLA

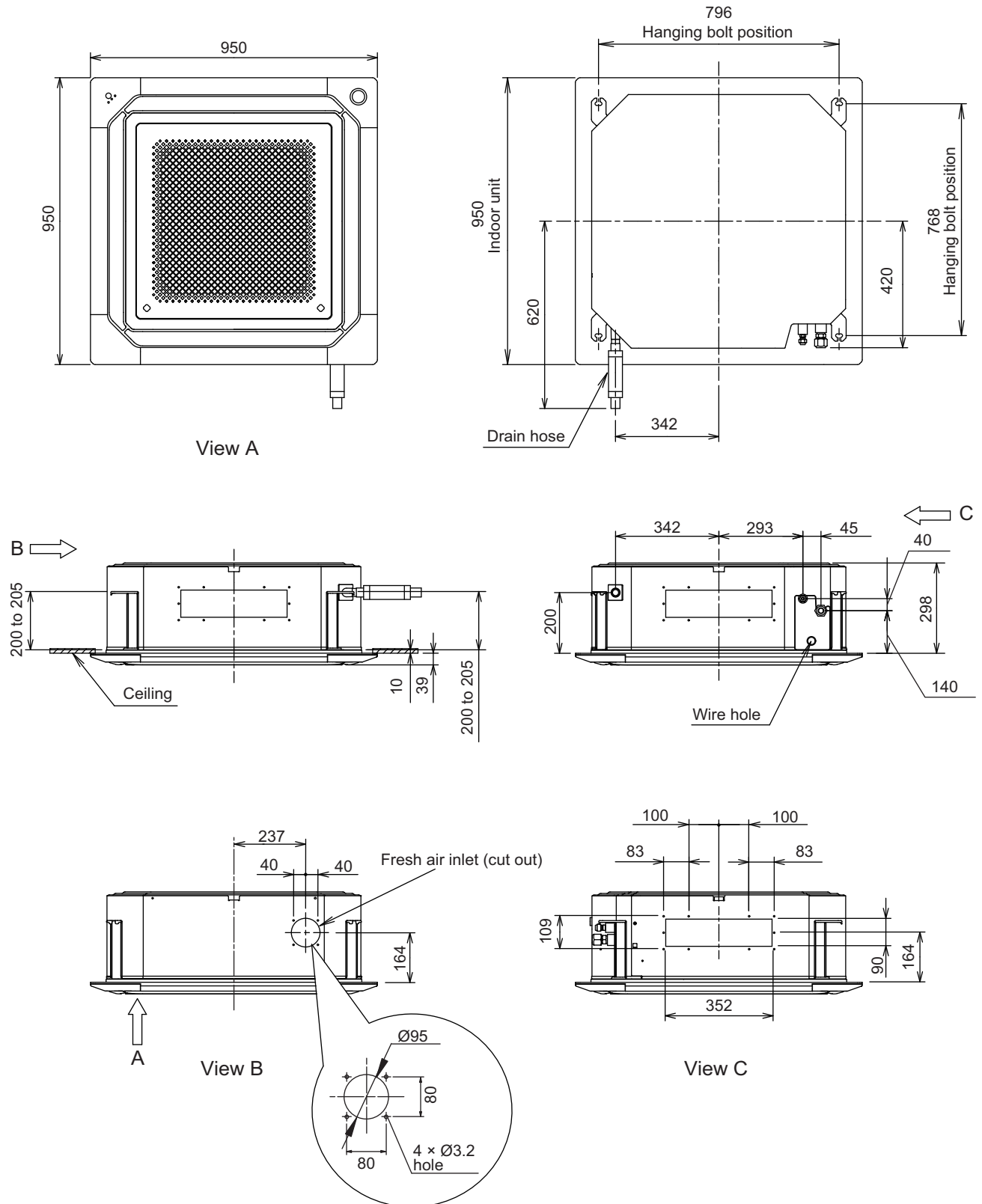

Installation space requirement

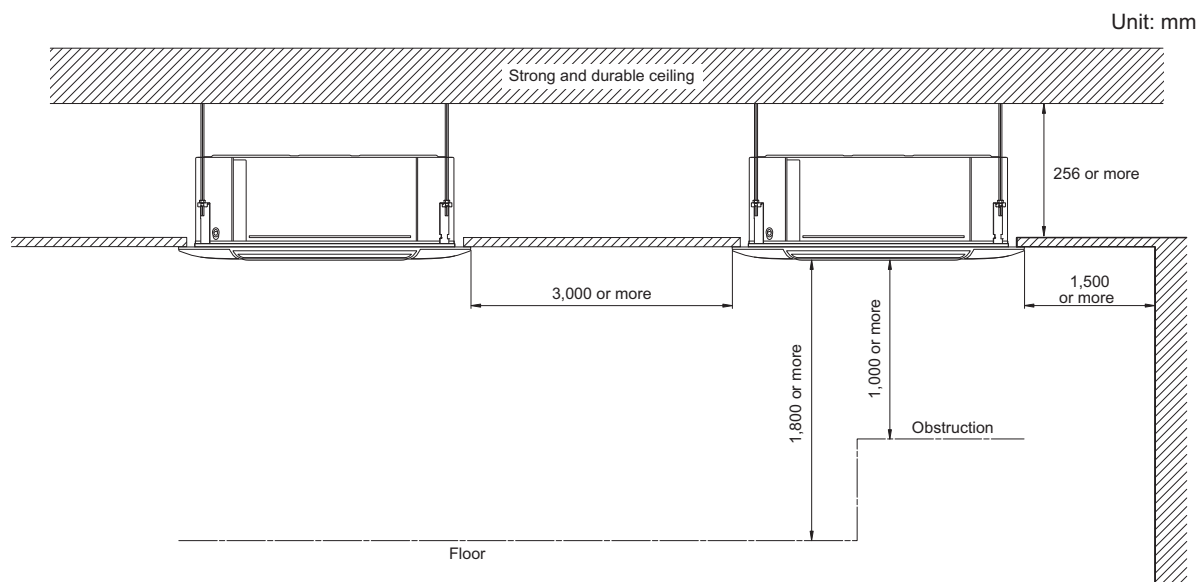

Maximum height from floor to ceiling (Unit: mm)			
Mode	AUHG30LRLE	AUHG36LRLE	AUHG45LRLA
Low	2,700		
Standard	3,200		
High ceiling	3,600	4,200	

3-way direction setting:

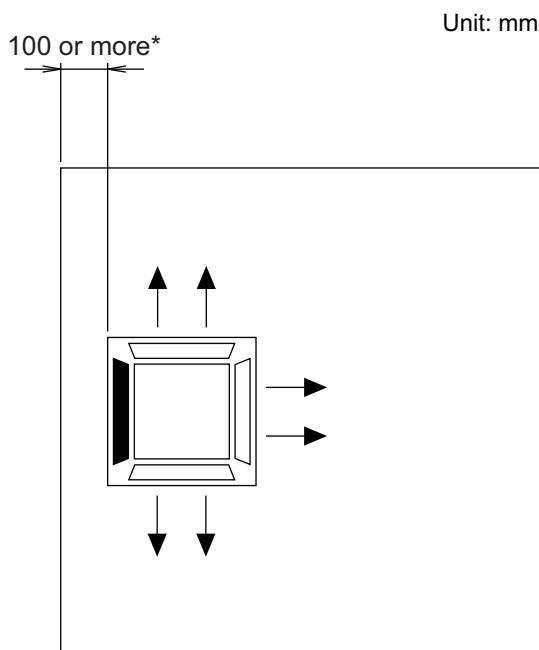

NOTES:

- To set "3-direction", optional Air outlet shutter plate (UTR-YDZB) must be installed, and the "outlet-direction" need to be switched to "3-way" by remote controller.
*When installing the indoor unit, be careful about the maintenance space.
- The ceiling height cannot be set in the 3-way outlet mode. Therefore, ceiling height setting change by function setting 20 is prohibited. For details, refer to ["Contents of function setting"](#) on page 284.

3-3. Slim duct type

■ Model: ARHG18LLTB

Unit: mm

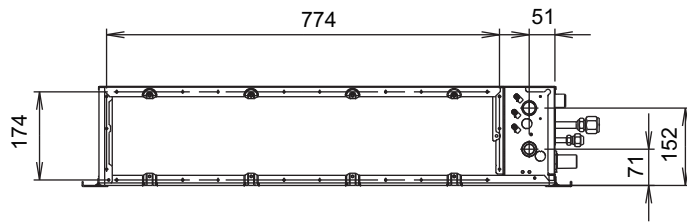

Rear view

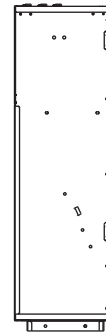

View A

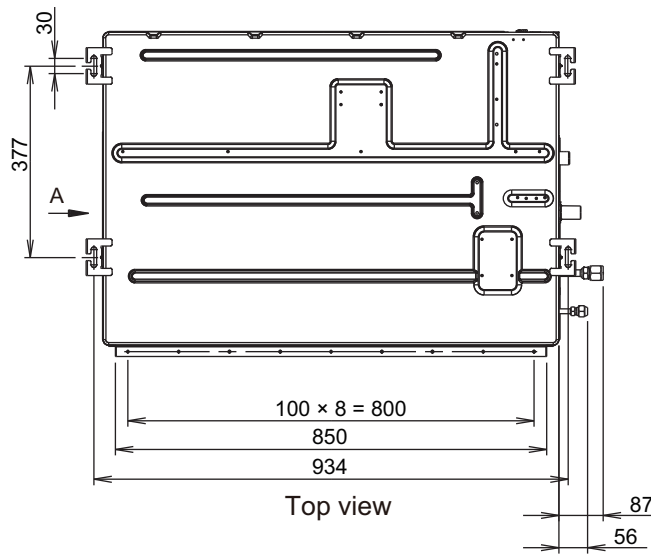

Top view

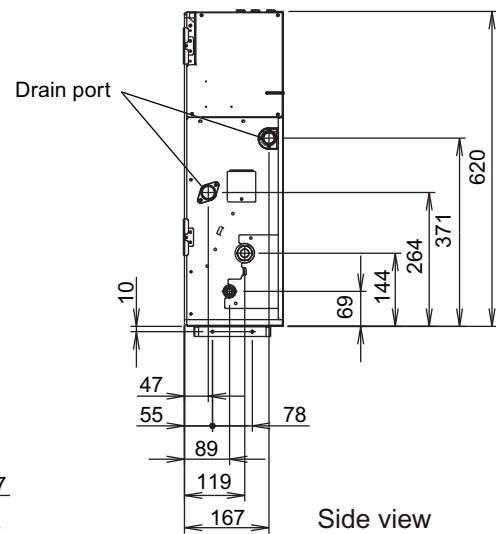

Side view

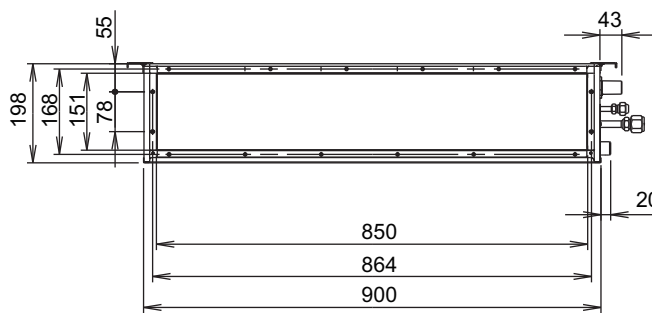

Front view

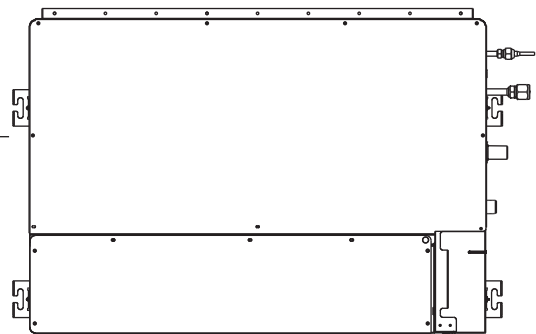

Bottom view

Installation space requirement

Provide sufficient installation space for product safety.

In ceiling-concealed installations:

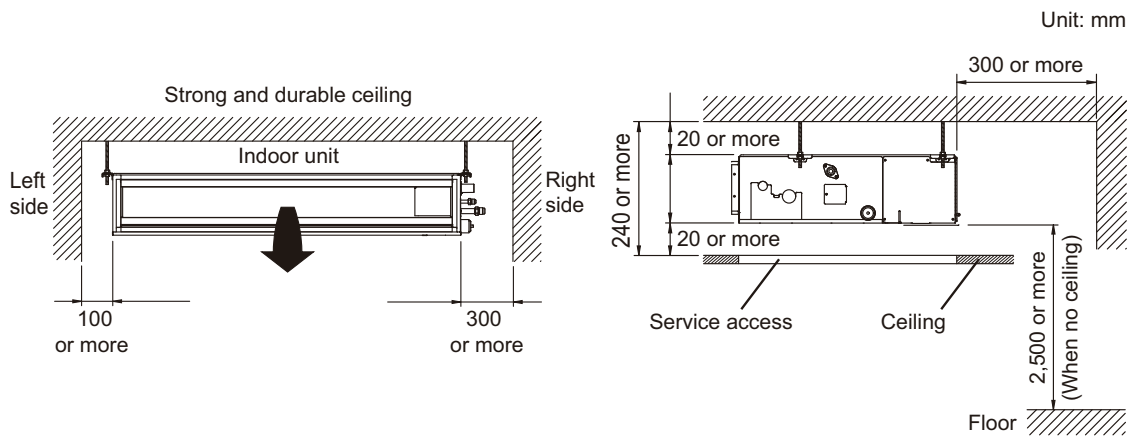

In wall-concealed installations:

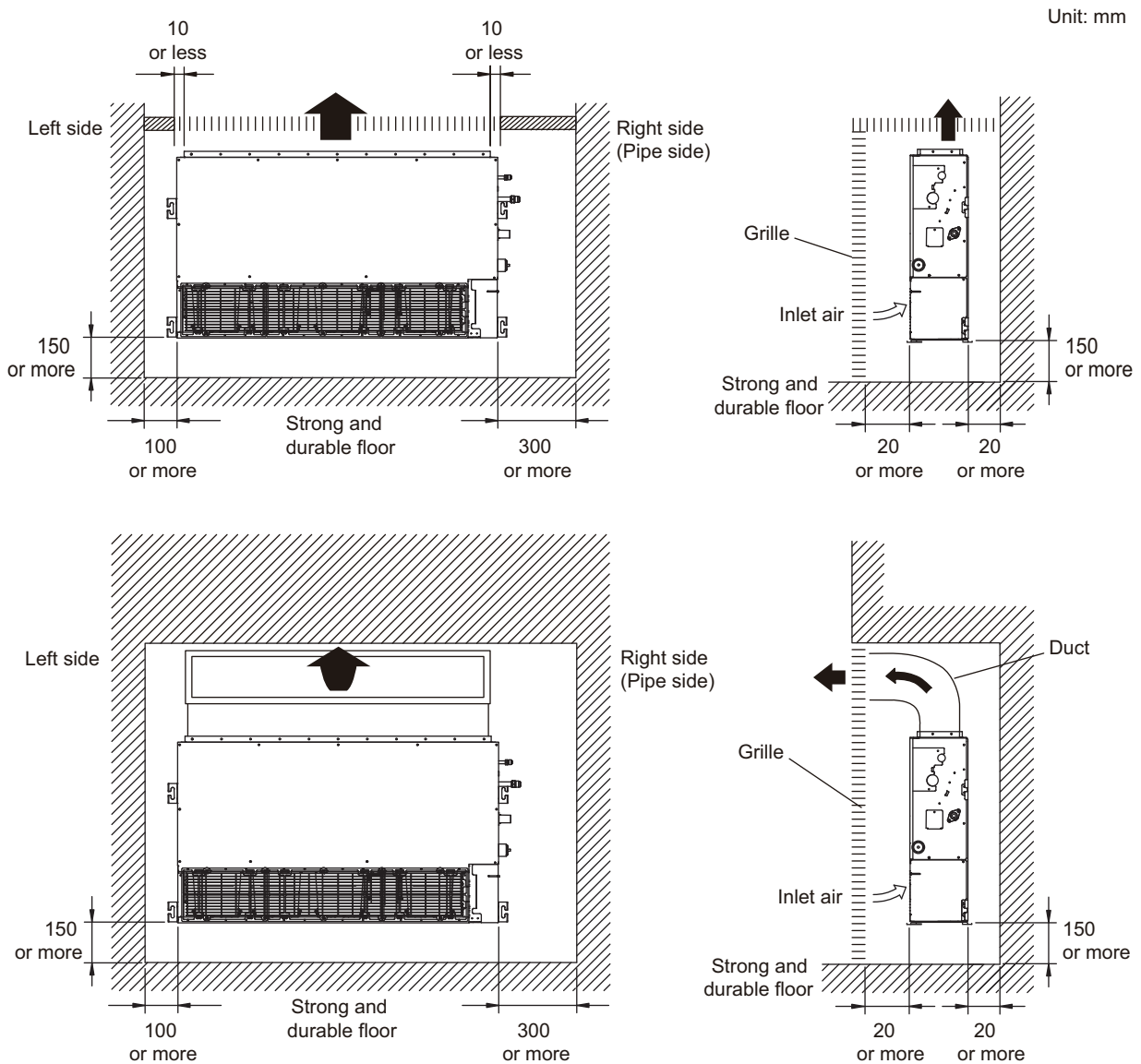

■ Maintenance space requirement

For future maintenance and service access, provide sufficient maintenance space.

NOTE: Do not place any wiring or illumination in the maintenance space, as they will impede service.

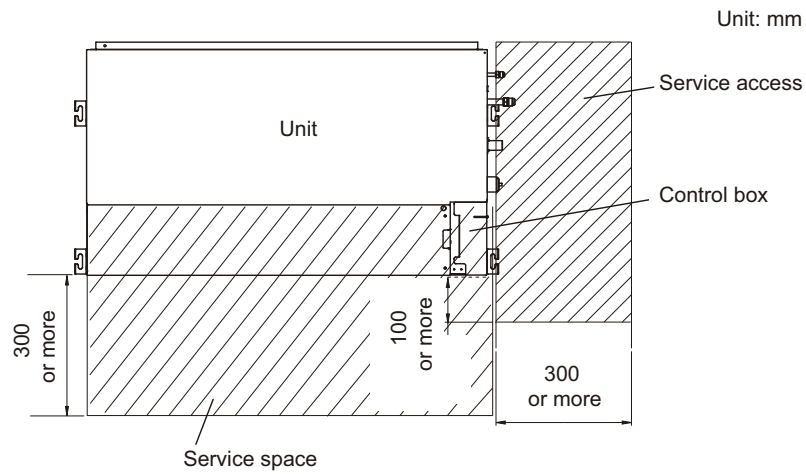

3-4. Duct type

■ Models: ARHG22LMLA, ARHG24LMLA, ARHG30LMLE, ARHG36LMLE, and ARHG45LMLA

Unit: mm

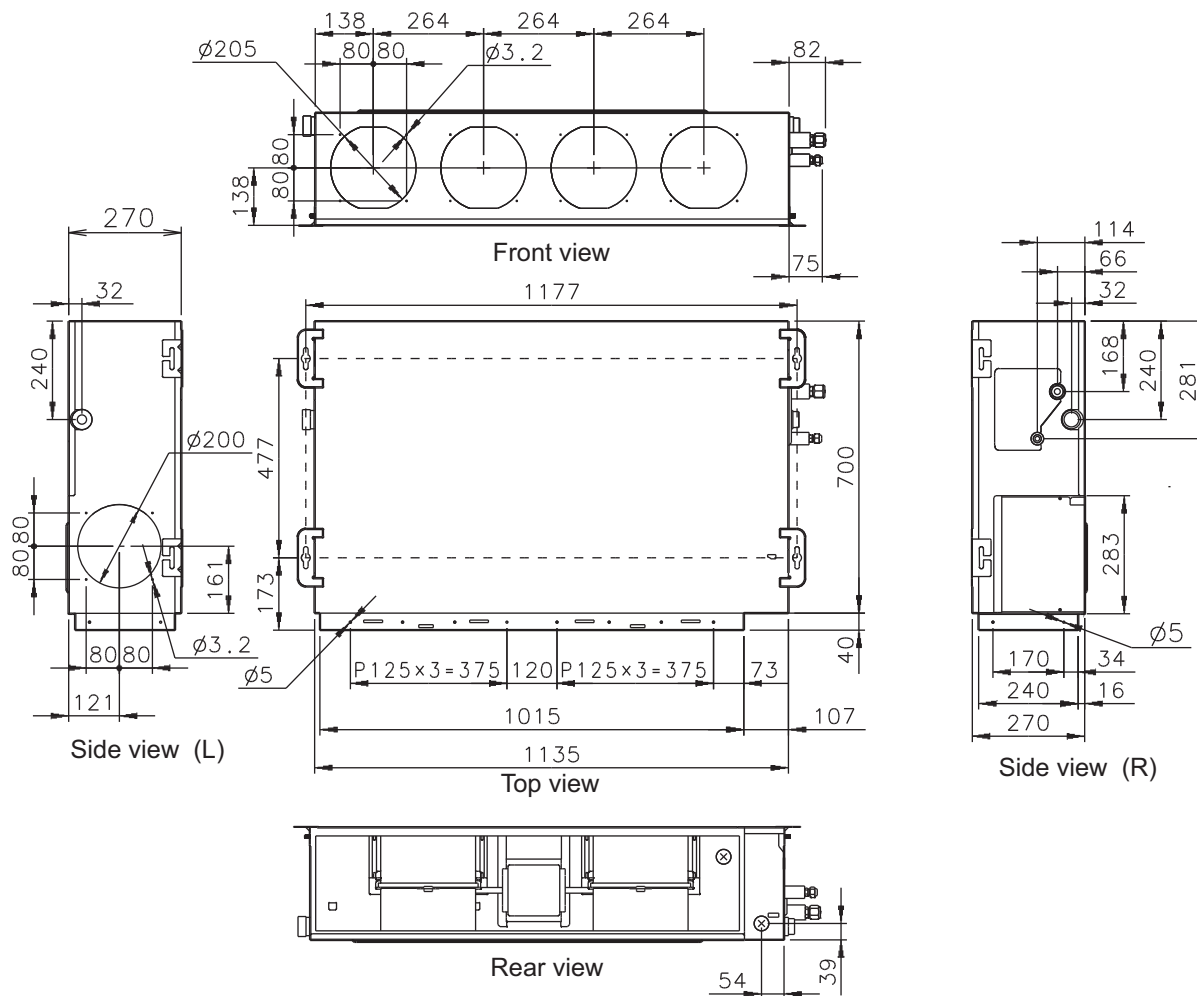

- When using a square duct

Unit: mm

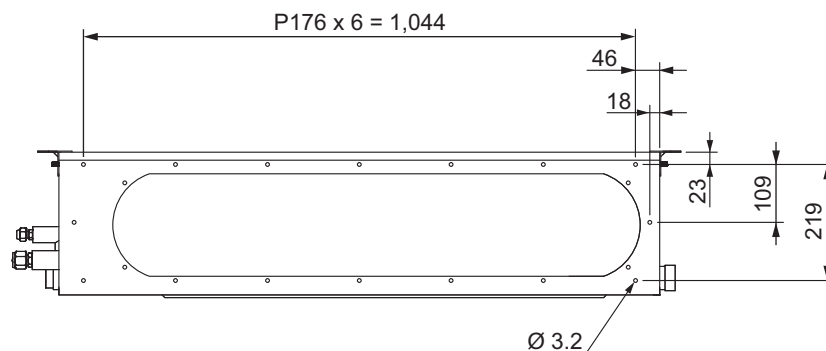

- Bottom air intake hole

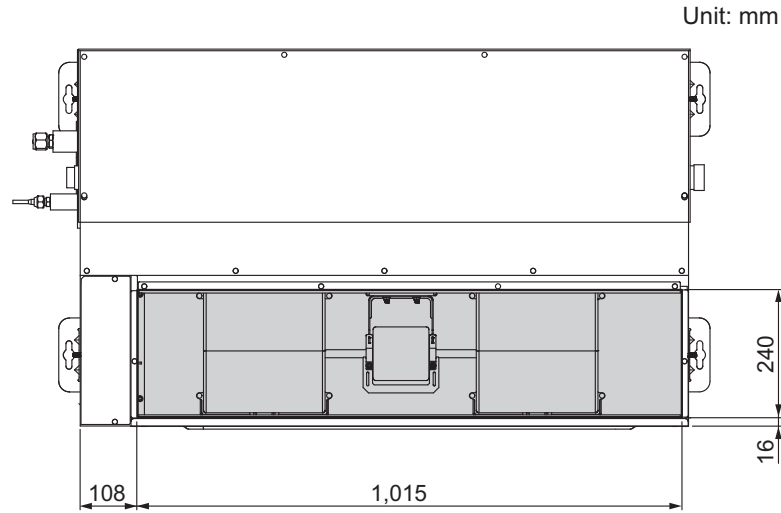

■ Installation space requirement

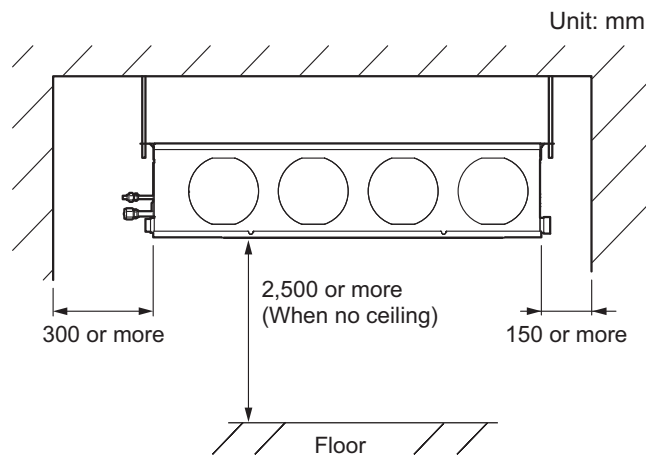

■ Maintenance space requirement

- It shall be possible to install and remove the control box.

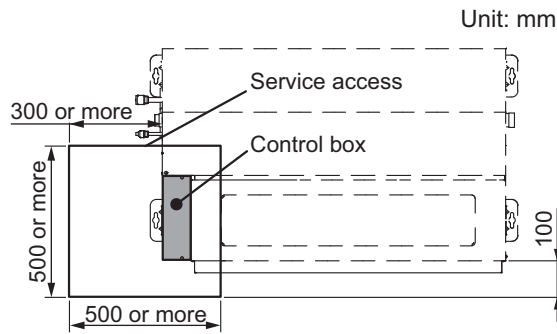

- It shall be possible to install and remove the control box, fan units and filter.

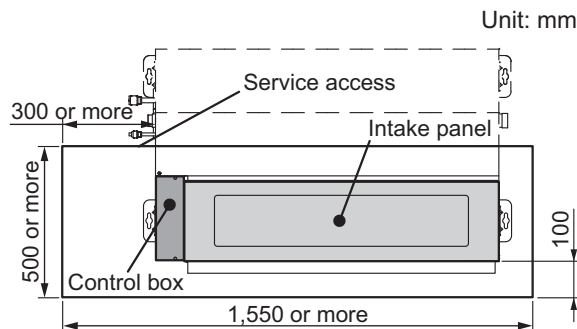

3-5. Floor/Ceiling type

■ Models: ABHG18LVTB, ABHG22LVTA, and ABHG24LVTA

Unit: mm

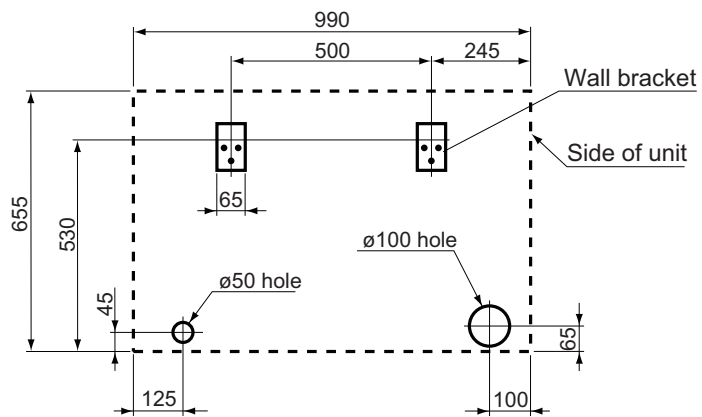
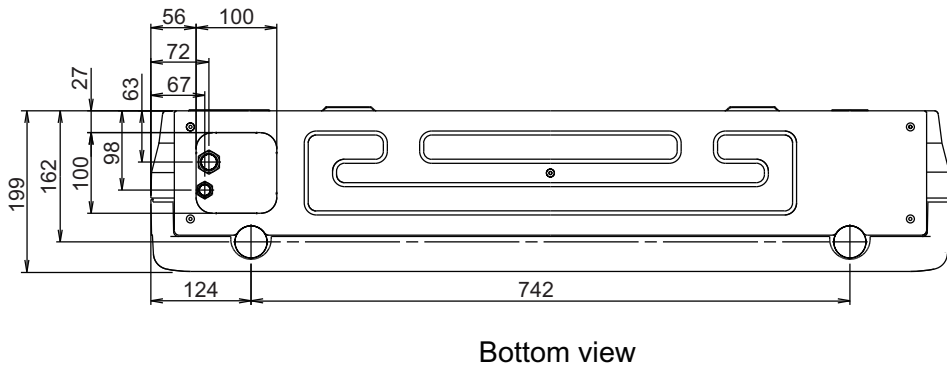
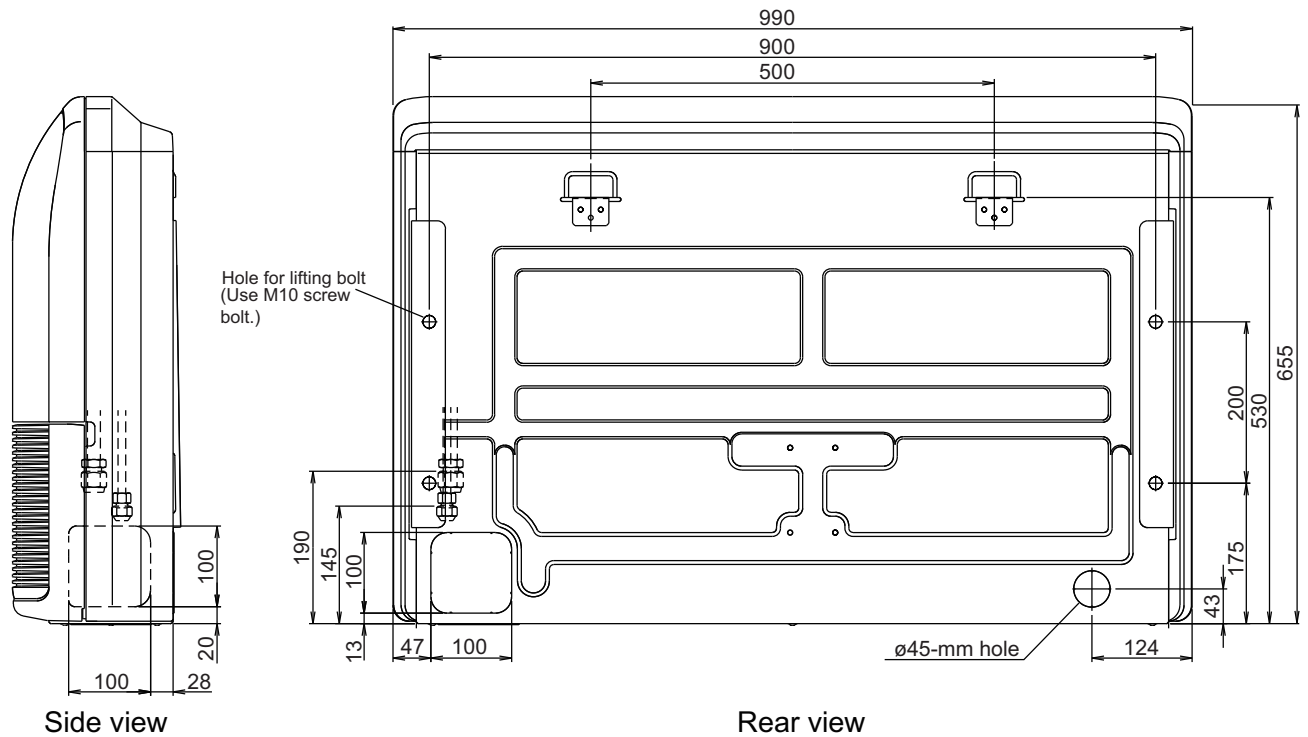

● Installation space

Unit: mm

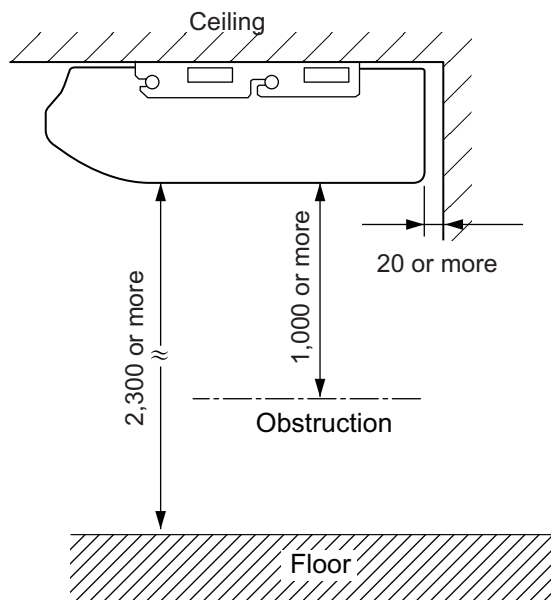
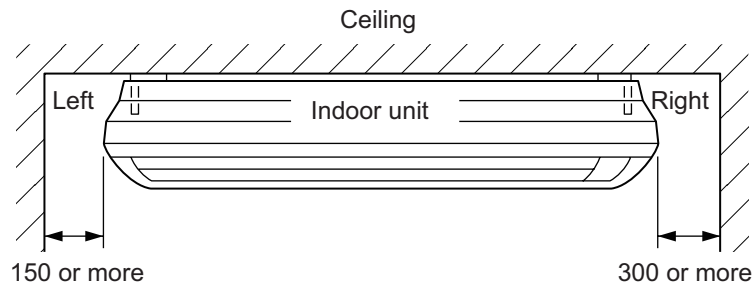
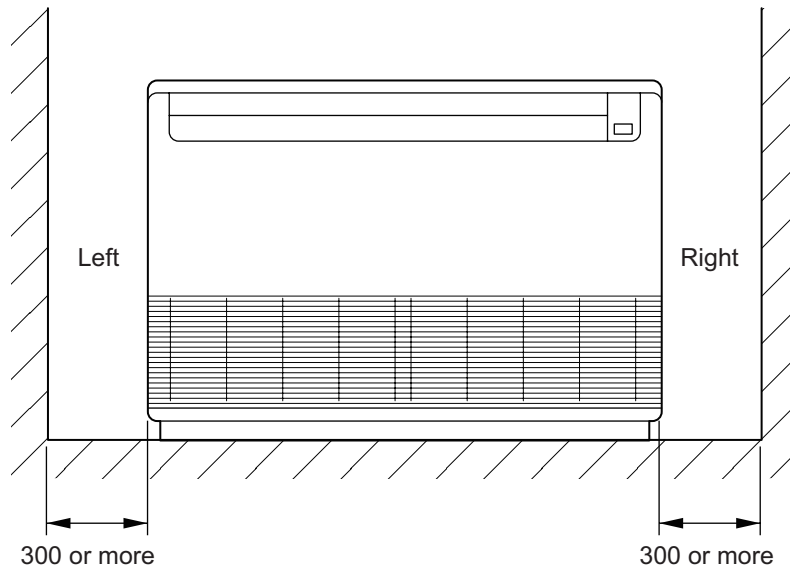

3-6. Ceiling type

■ Models: ABHG30LRTE, ABHG36LRTE, and ABHG45LRTA

Unit: mm

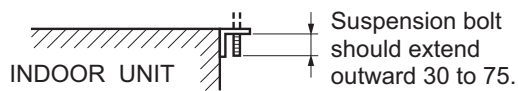
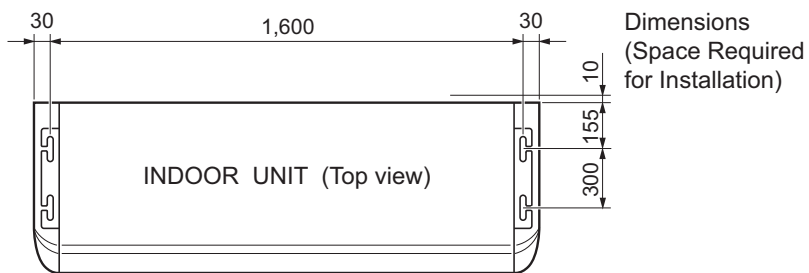
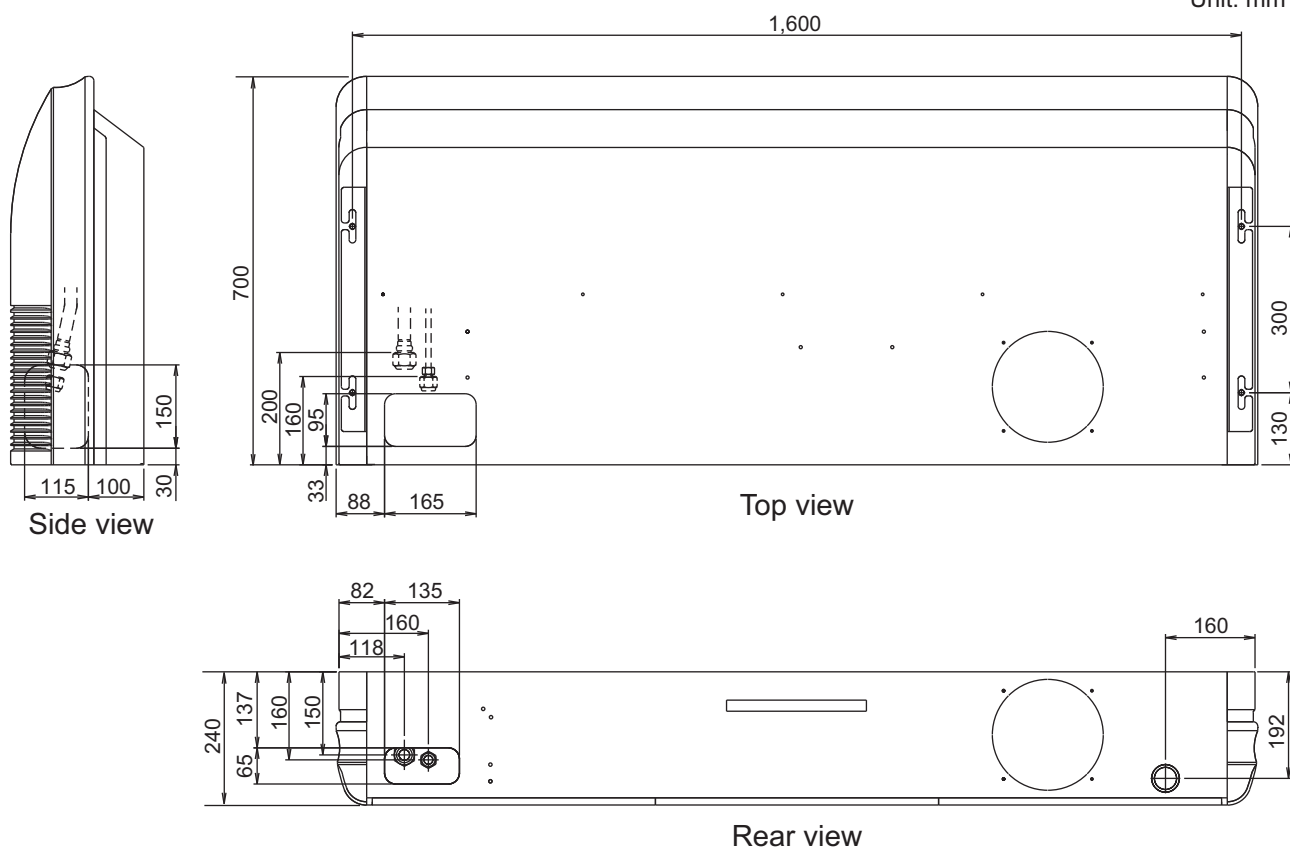

Installation space requirement

Unit: mm

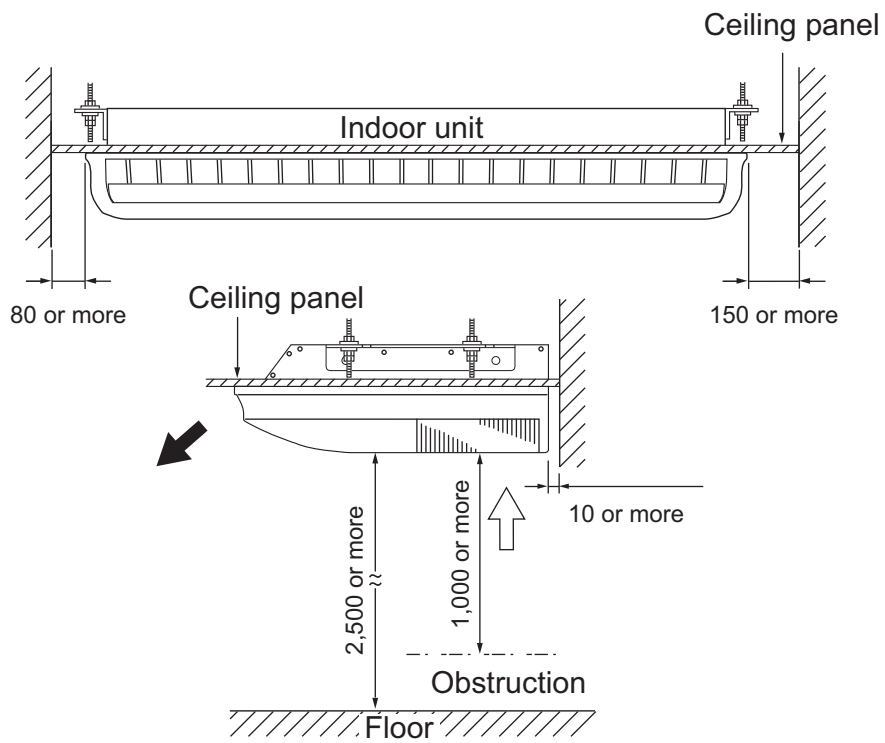
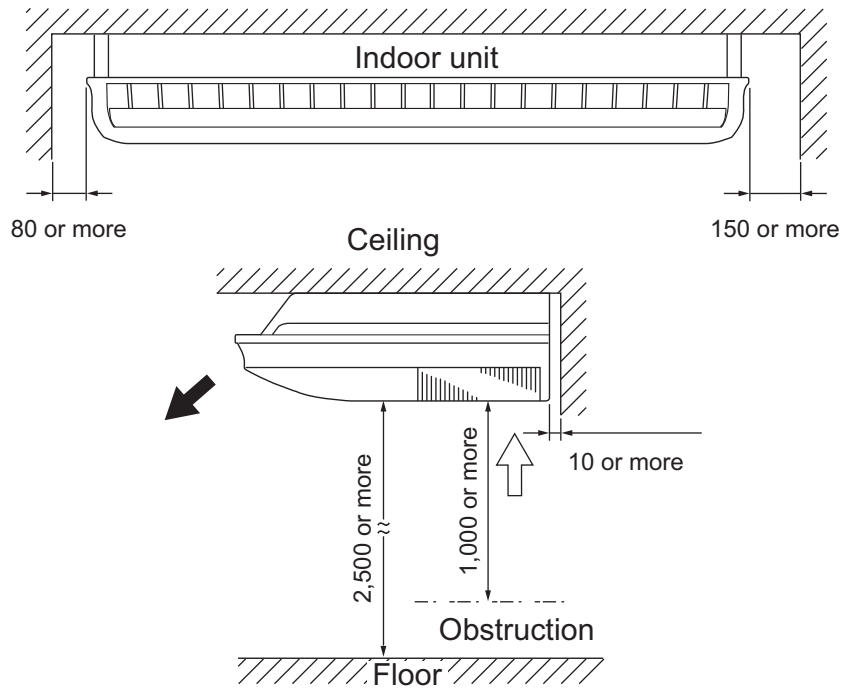

4. Wiring diagrams

4-1. Compact cassette type

■ Models: AUHG18LVLB, AUHG22LVLA, and AUHG24LVLA

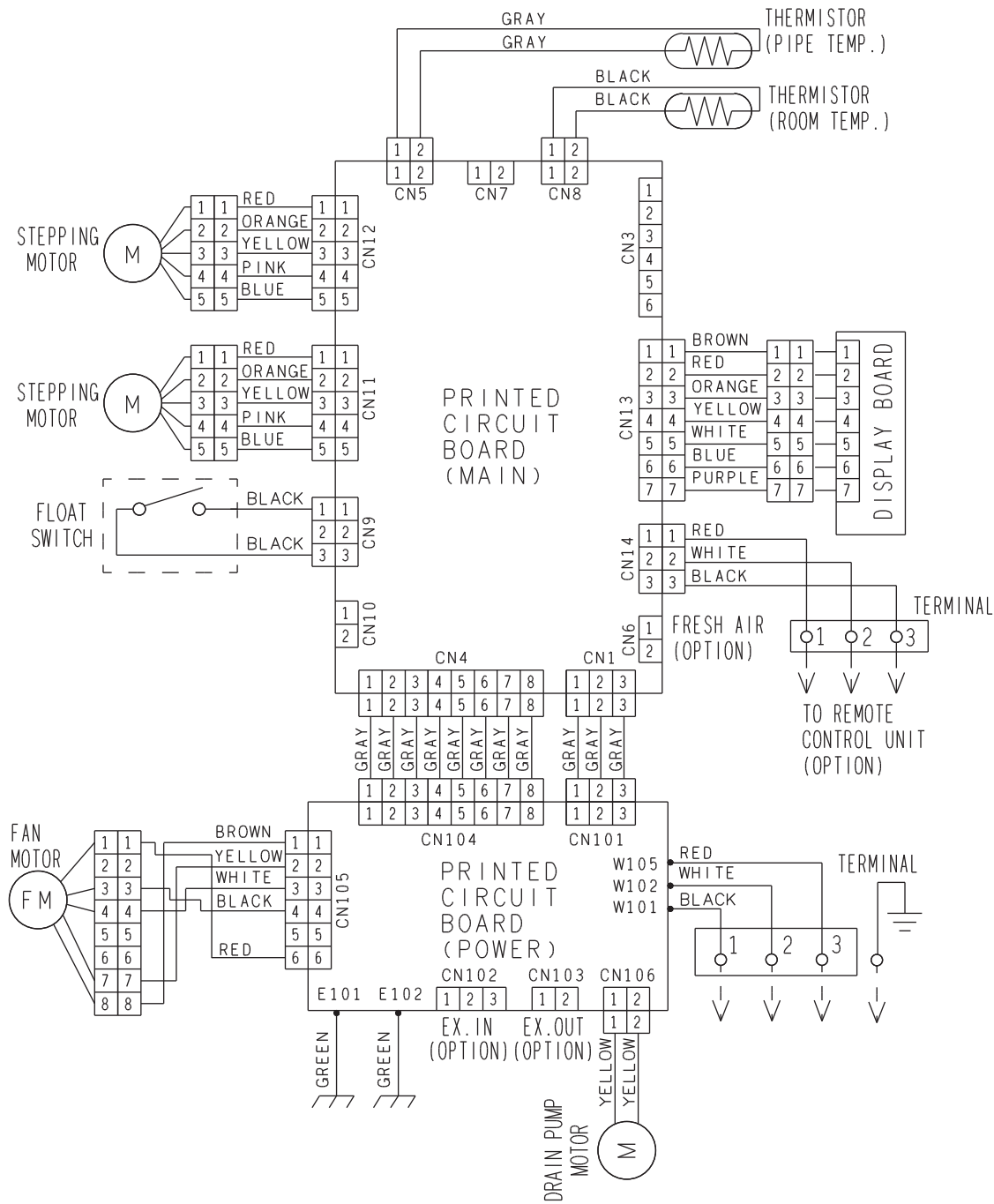

4-2. Cassette type

Models: AUHG30LRLE, AUHG36LRLE, and AUHG45LRLE

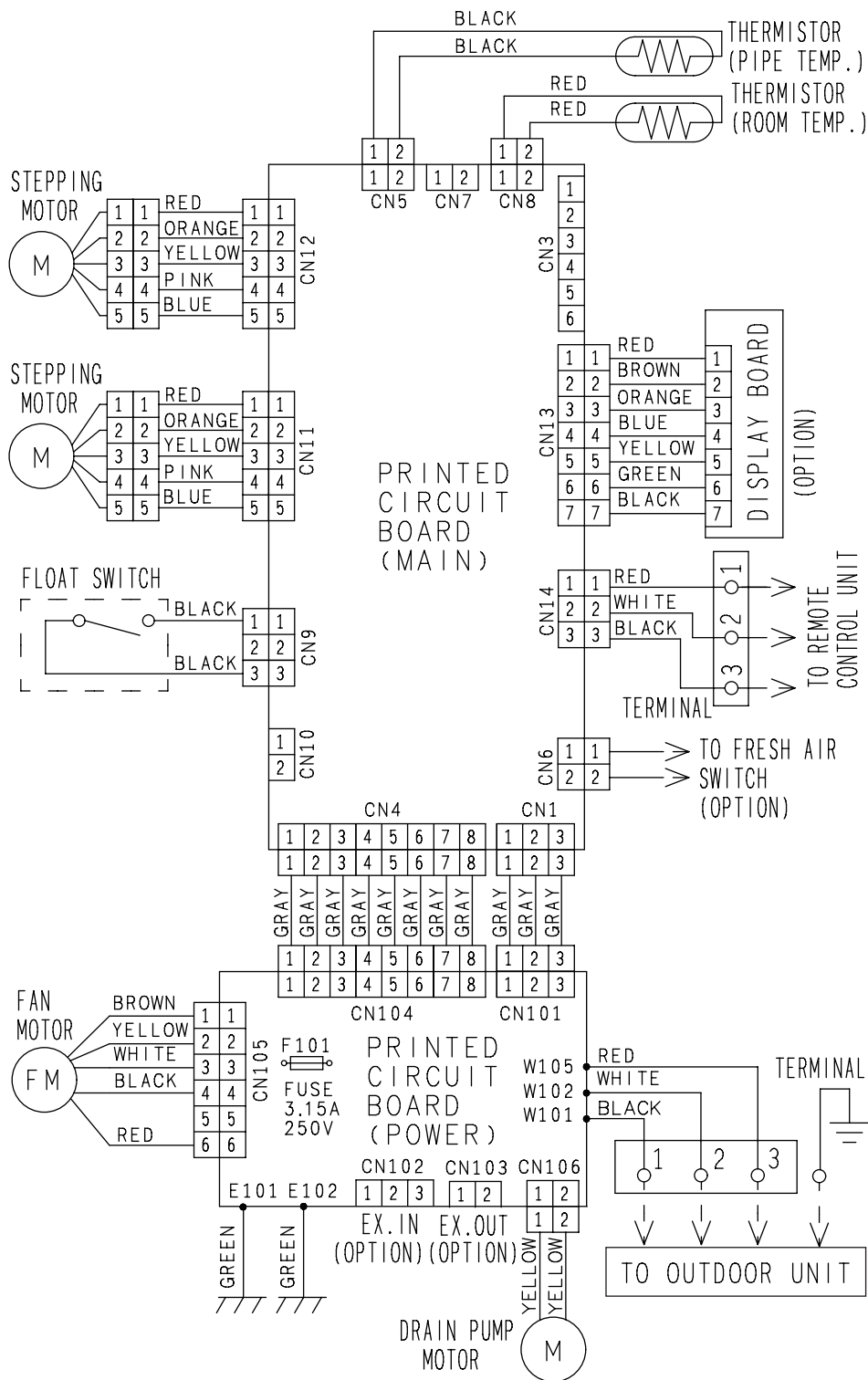

4-3. Slim duct type

Model: ARHG18LLTB

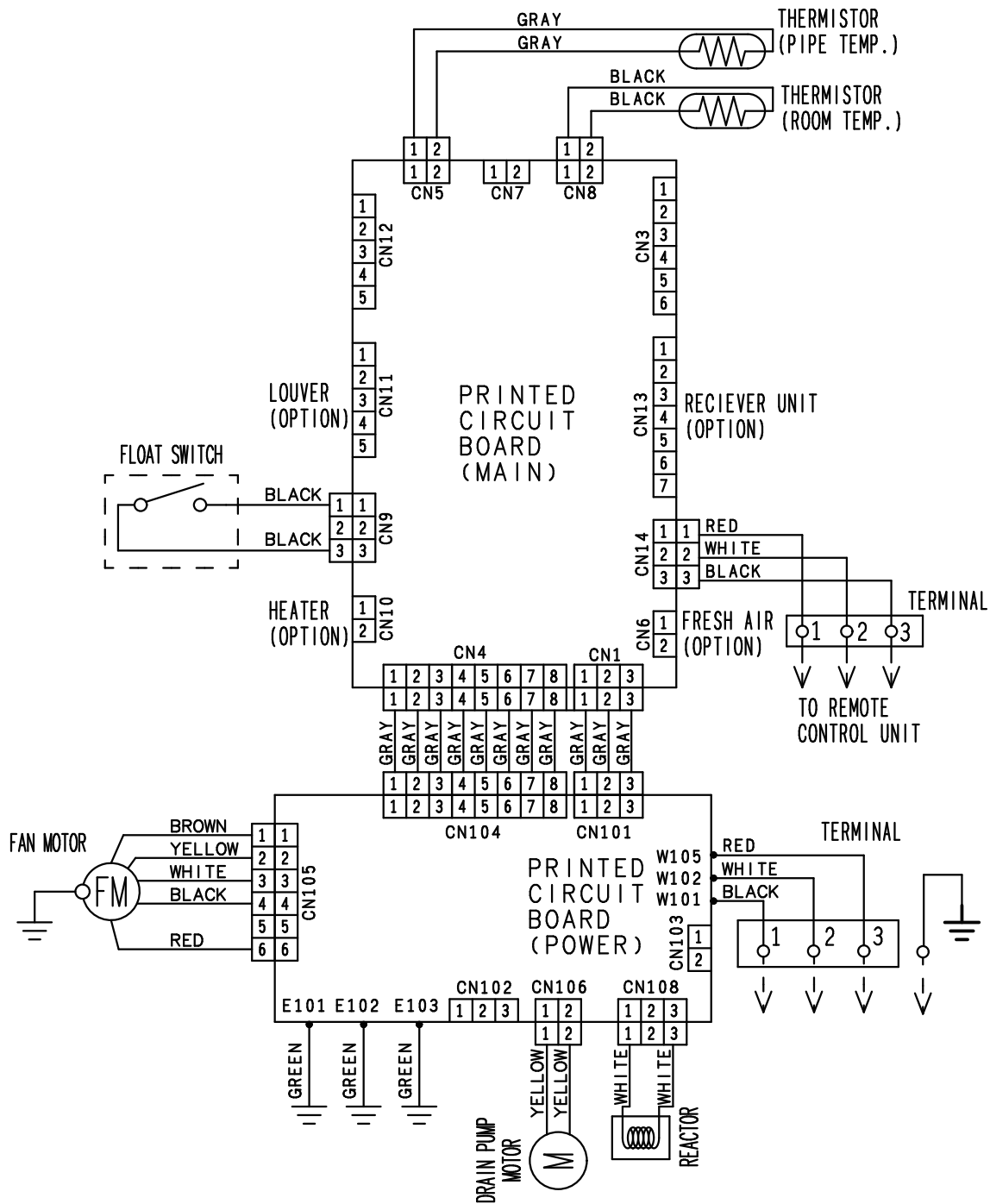

4-4. Duct type

Models: ARHG22LMLA and ARHG24LMLA

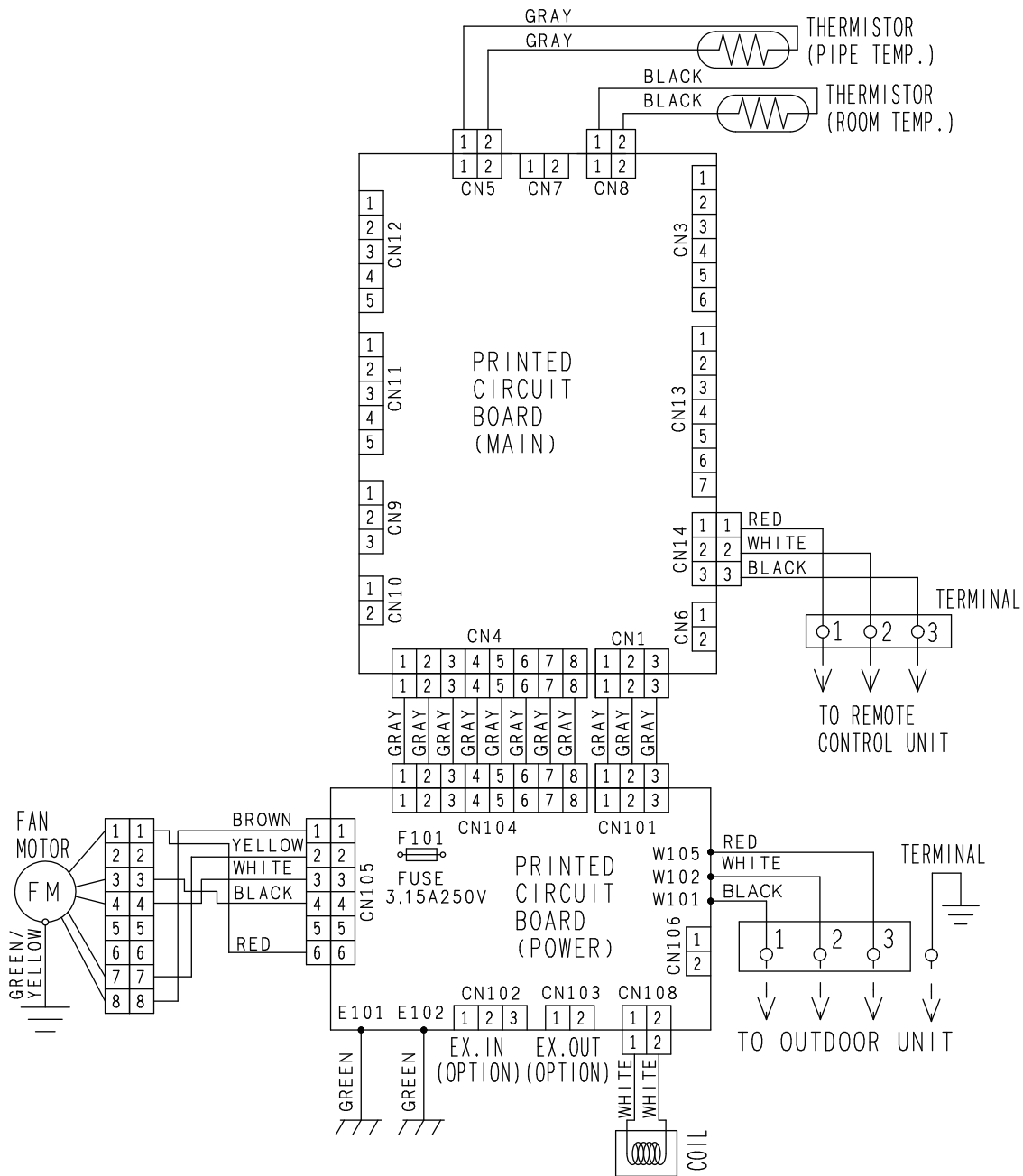

Models: ARHG30LMLE, ARHG36LMLE, and ARHG45LMLA

INDOOR UNITS
SIMULTANEOUS
MULTI

INDOOR UNITS
SIMULTANEOUS
MULTI

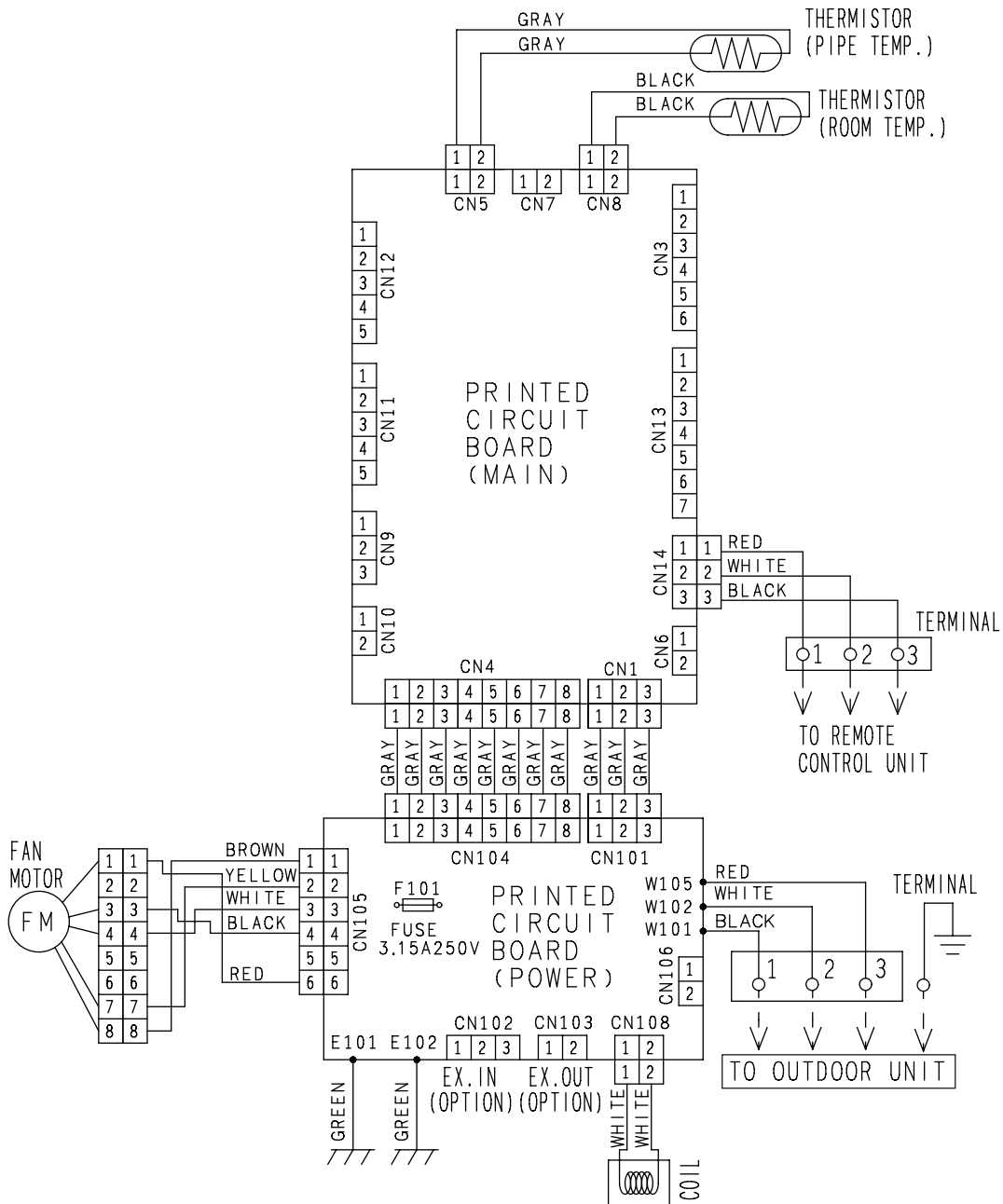

4-5. Floor/Ceiling type

Models: ABHG18LVTB, ABHG22LVTA, and ABHG24LVTA

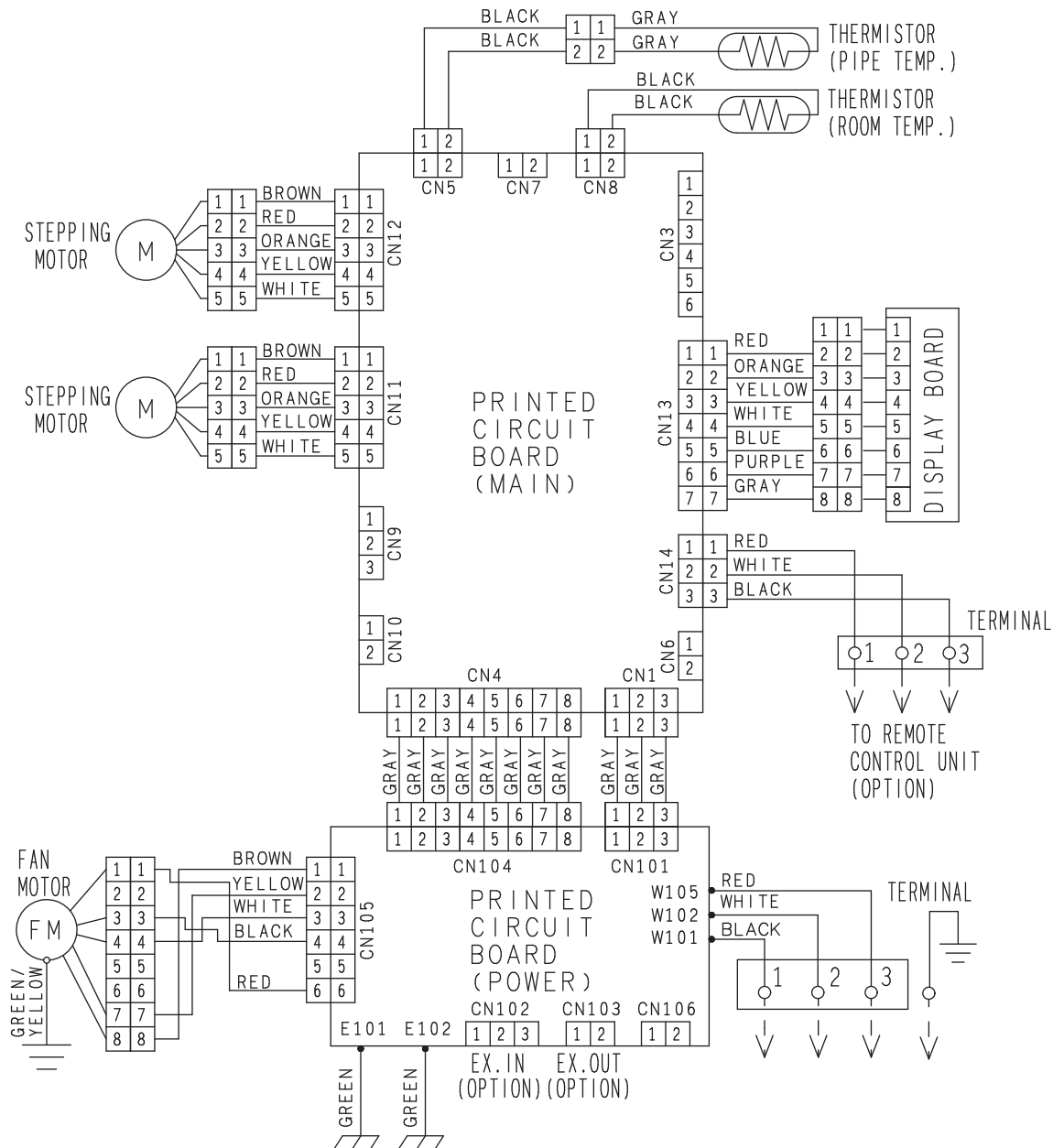

4-6. Ceiling type

Models: ABHG30LRTE, ABHG36LRTE, and ABHG45LRTA

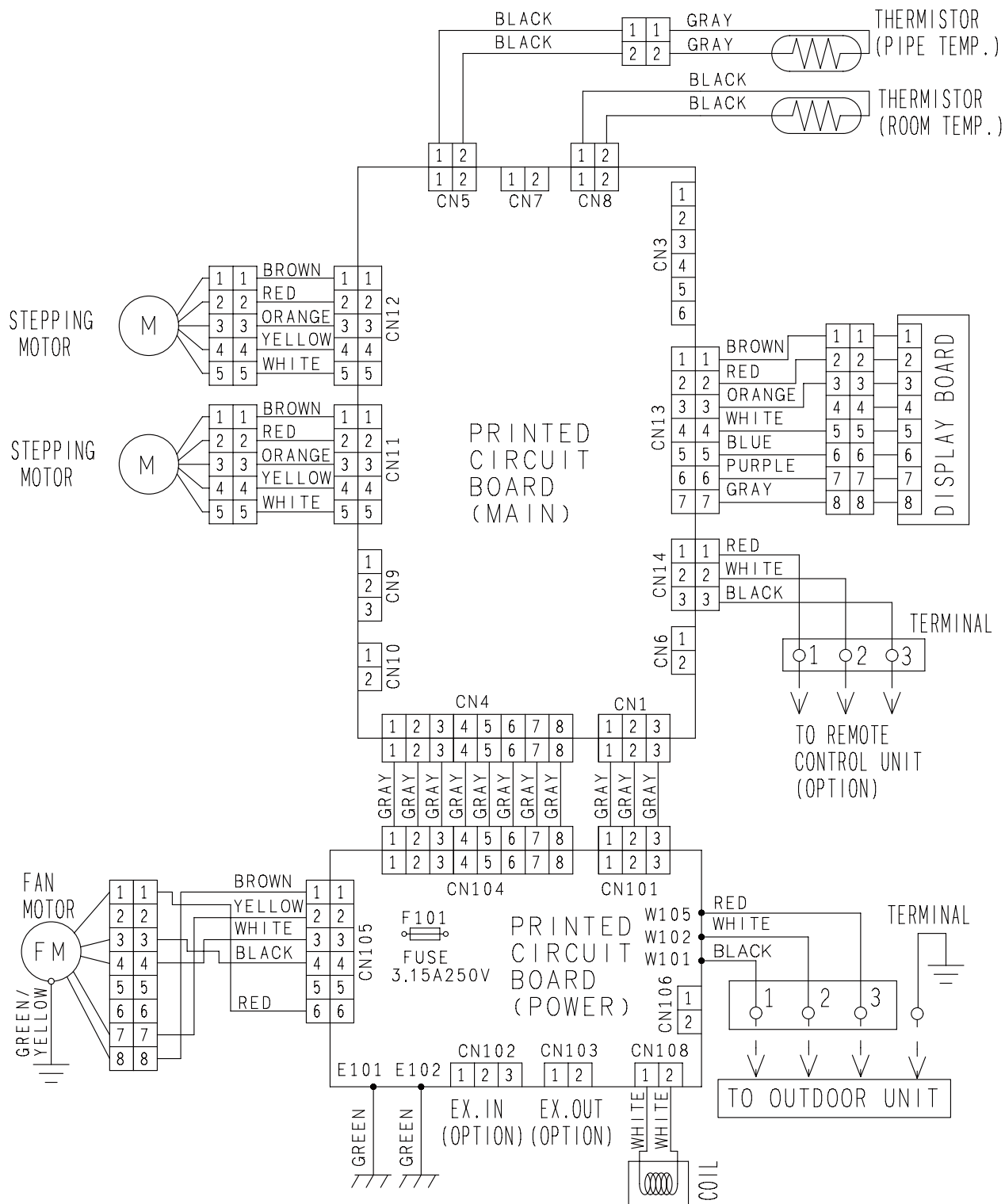

5. Air velocity and temperature distributions

5-1. Compact cassette type

■ Model: AUHG18LVLB (4-way air outlet)

Measuring conditions	Fan speed	Operation mode	Ceiling mode
	HIGH	FAN	STANDARD

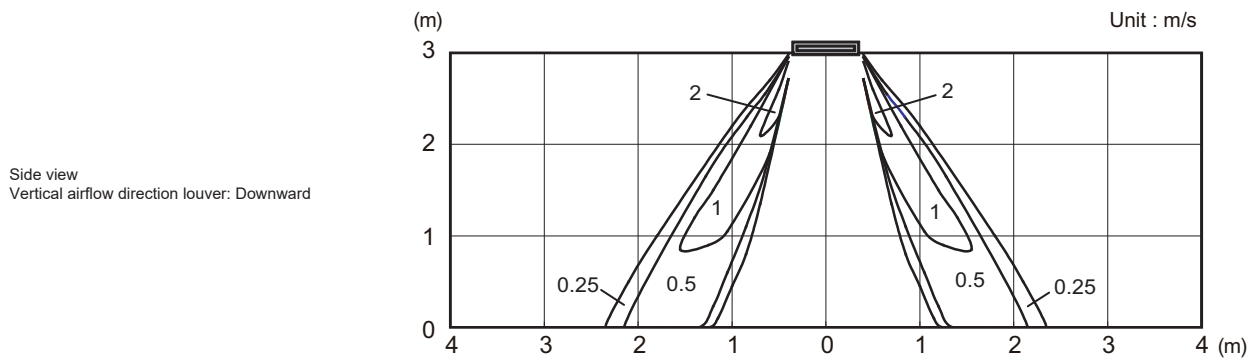
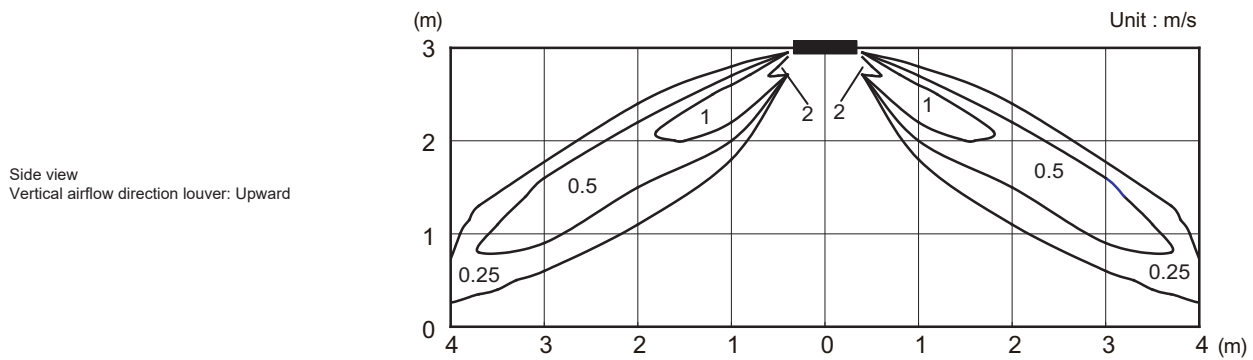
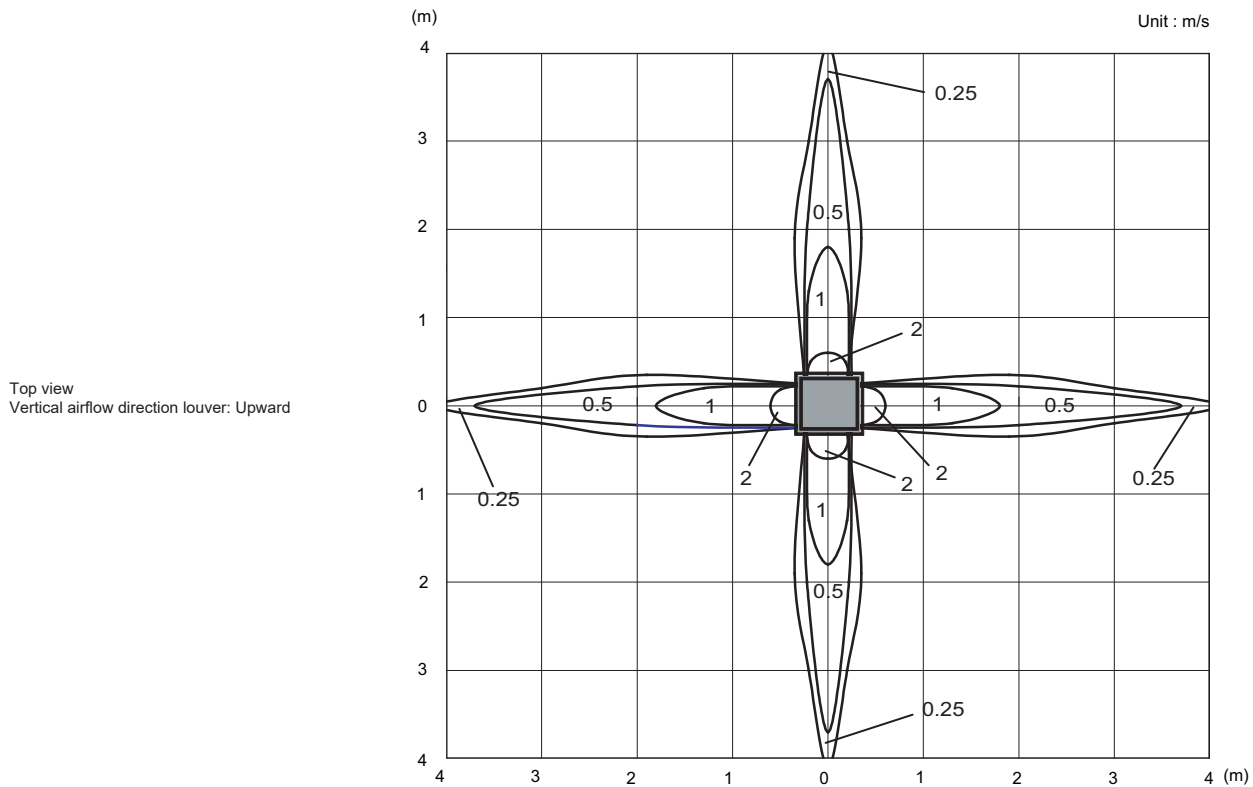

Model: AUHG18LVLB (3-way air outlet)

Measuring conditions	Fan speed	Operation mode	Ceiling mode
	HIGH	FAN	STANDARD

Top view
Vertical airflow direction louver: Upward

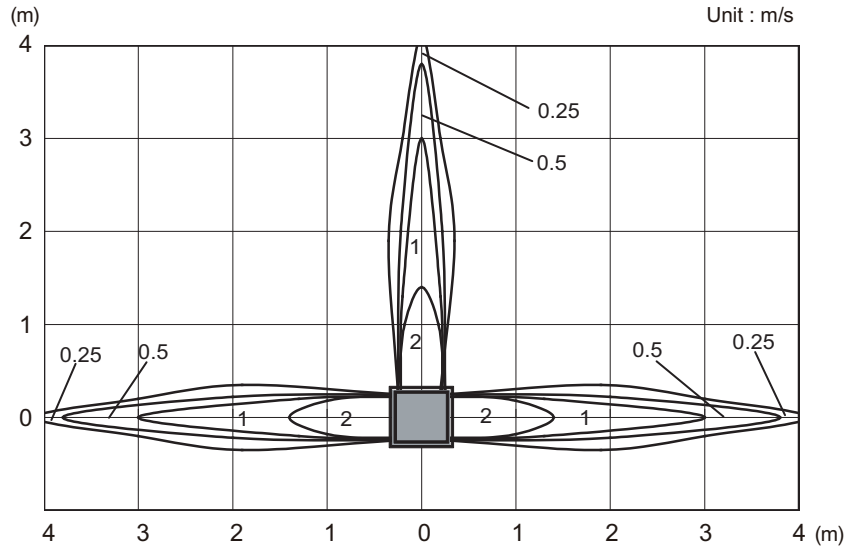

Side view
Vertical airflow direction louver: Upward

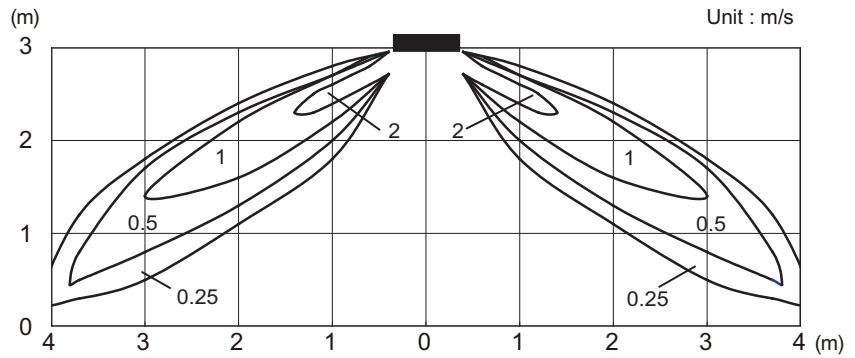

Side view
Vertical airflow direction louver: Downward

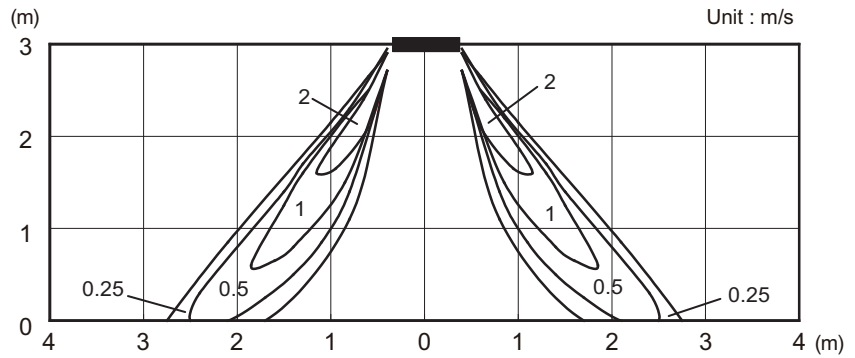

Model: AUHG22LVLA (4-way air outlet)

INDOOR UNITS
SIMULTANEOUS
MULTI

INDOOR UNITS
SIMULTANEOUS
MULTI

Measuring conditions	Fan speed	Operation mode	Ceiling mode
	HIGH	FAN	STANDARD

Top view
Vertical airflow direction louver: Upward

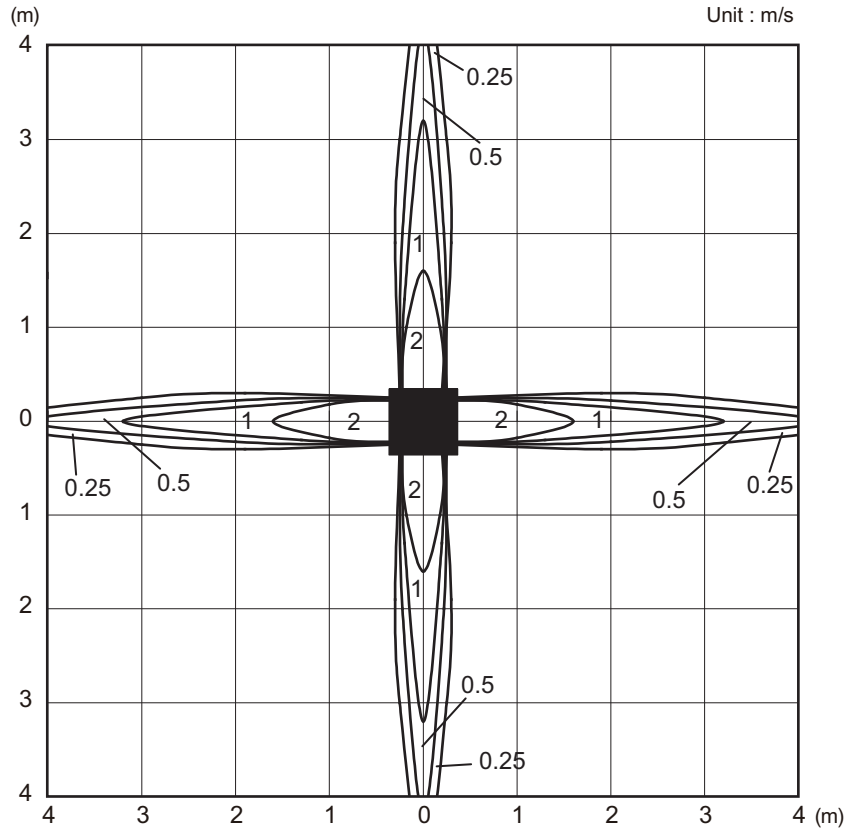

Side view
Vertical airflow direction louver: Upward

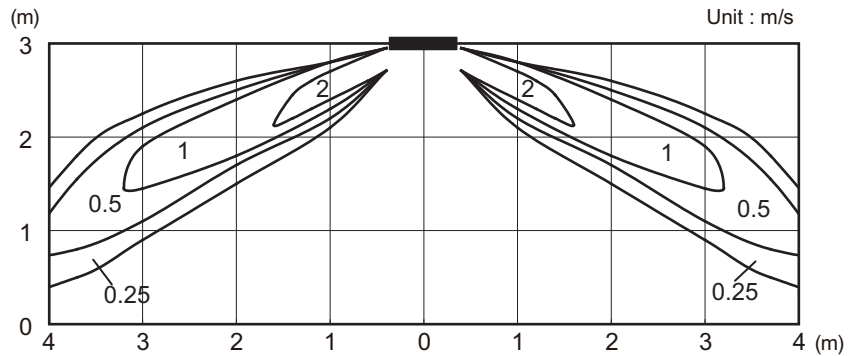

Side view
Vertical airflow direction louver: Downward

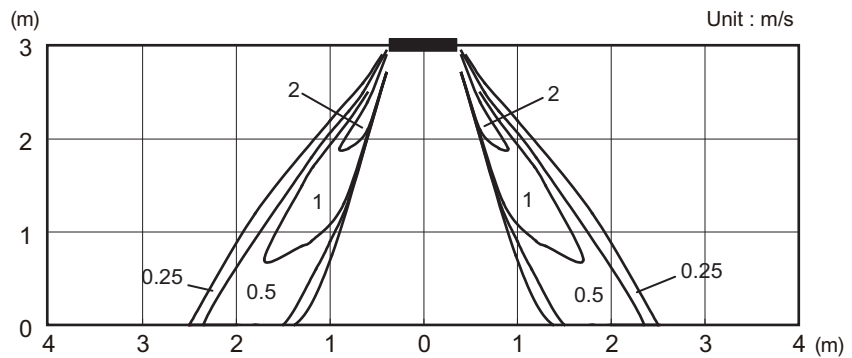

Model: AUHG22LVLA (3-way air outlet)

Measuring conditions	Fan speed	Operation mode	Ceiling mode
	HIGH	FAN	STANDARD

Top view
Vertical airflow direction louver: Upward

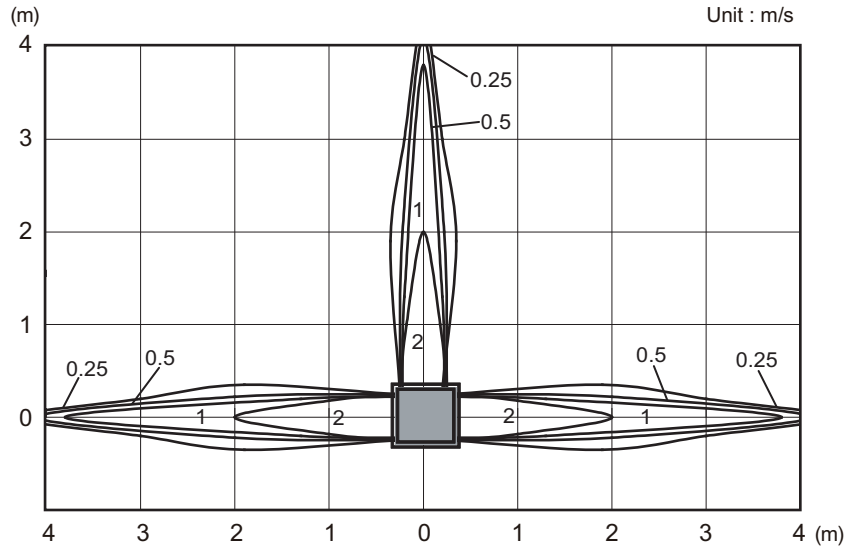

Side view
Vertical airflow direction louver: Upward

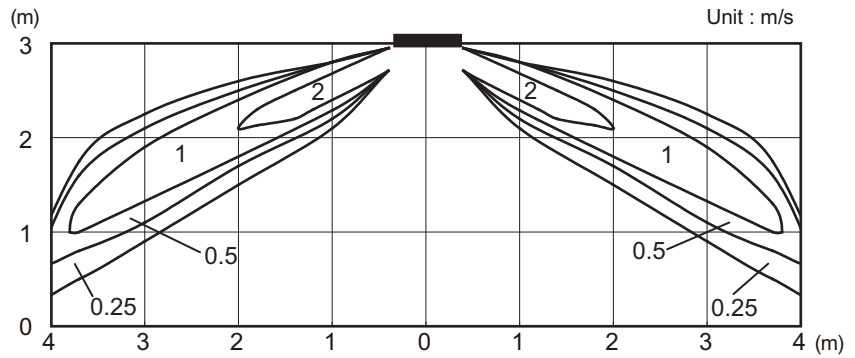

Side view
Vertical airflow direction louver: Downward

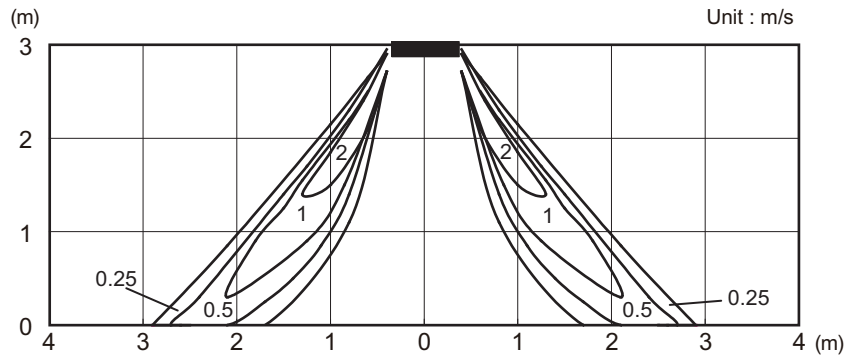

Model: AUHG24LVLA (4-way air outlet)

INDOOR UNITS
SIMULTANEOUS
MULTI

INDOOR UNITS
SIMULTANEOUS
MULTI

Measuring conditions	Fan speed	Operation mode	Ceiling mode
	HIGH	FAN	STANDARD

Top view
Vertical airflow direction louver: Upward

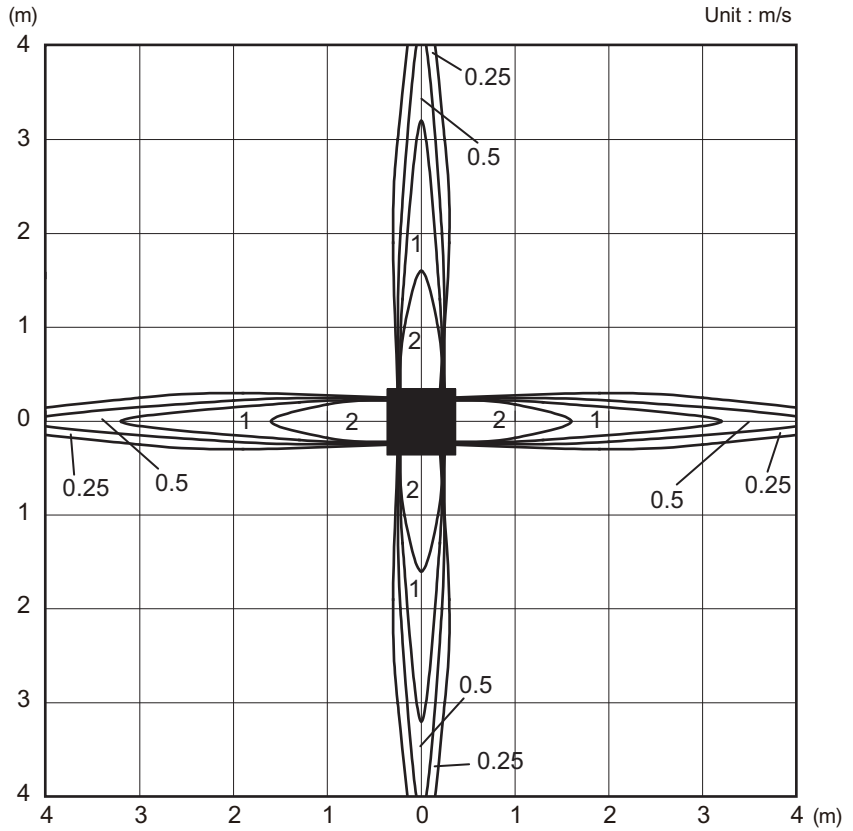

Side view
Vertical airflow direction louver: Upward

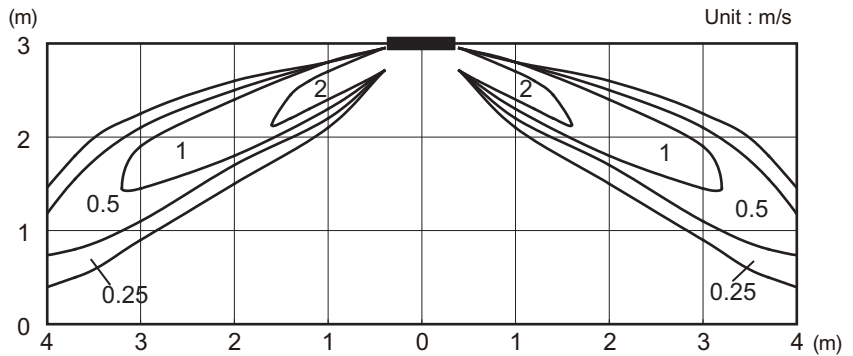

Side view
Vertical airflow direction louver: Downward

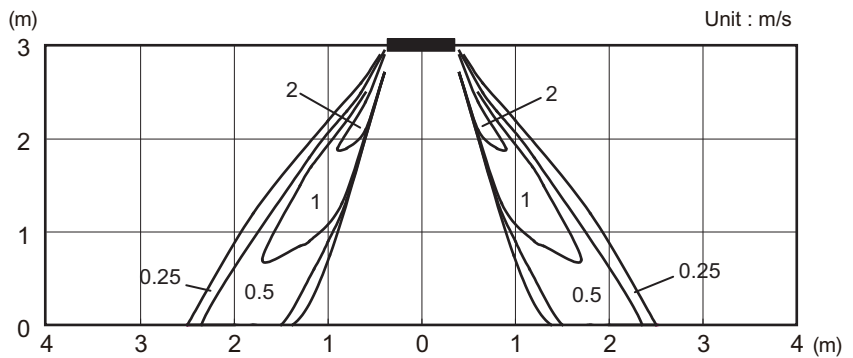

Model: AUHG24LVLA (3-way air outlet)

Measuring conditions	Fan speed	Operation mode	Ceiling mode
	HIGH	FAN	STANDARD

Top view
Vertical airflow direction louver: Upward

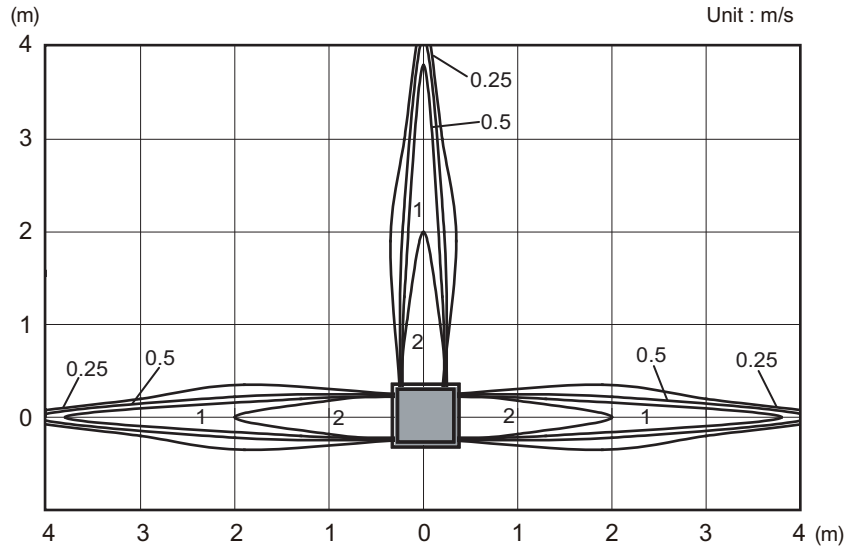

Side view
Vertical airflow direction louver: Upward

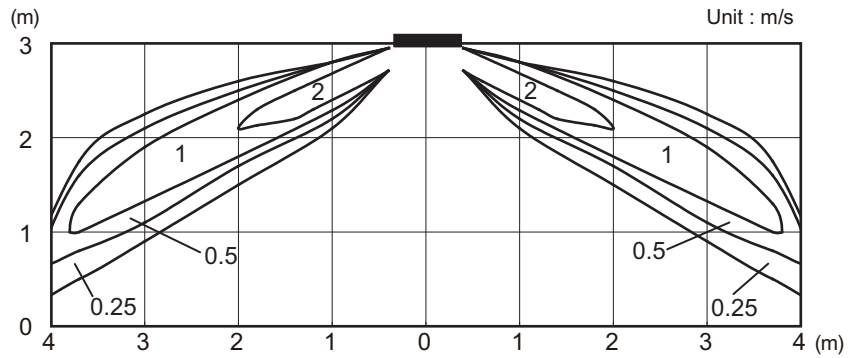

Side view
Vertical airflow direction louver: Downward

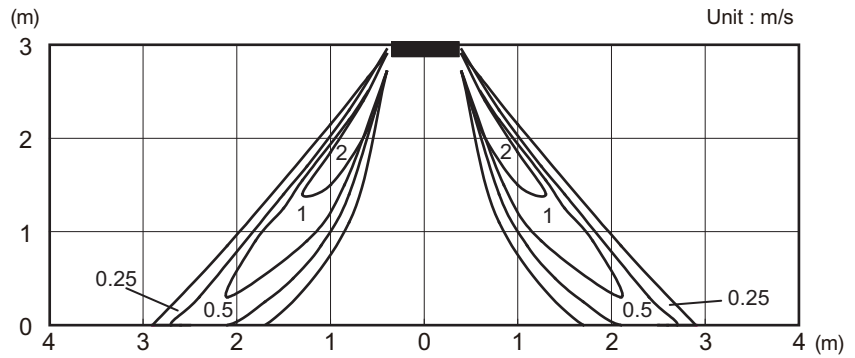

5-2. Cassette type

Model: AUHG30LRLE (4-way air outlet)

Measuring conditions	Fan speed	Operation mode	Ceiling mode
	HIGH	FAN	STANDARD

Top view
Vertical airflow direction louver: Upward

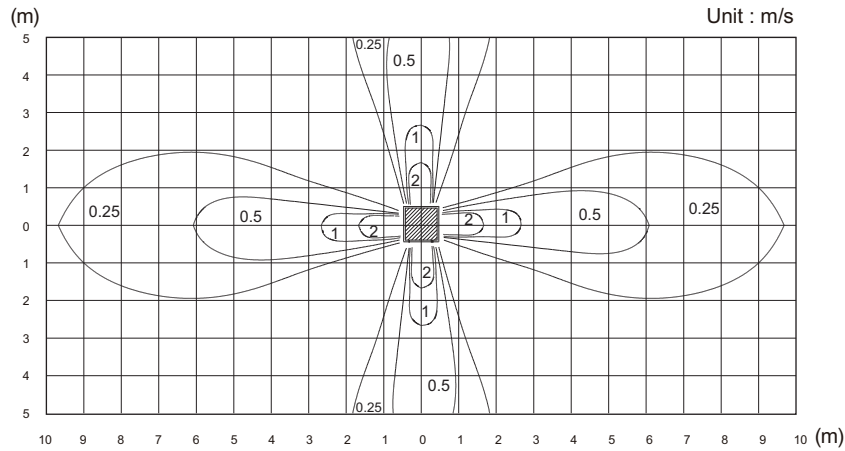

Side view
Vertical airflow direction louver: Upward

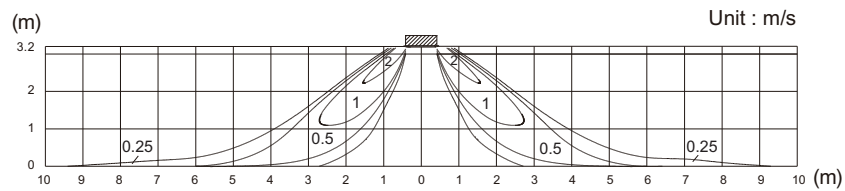

Side view
Vertical airflow direction louver: Downward

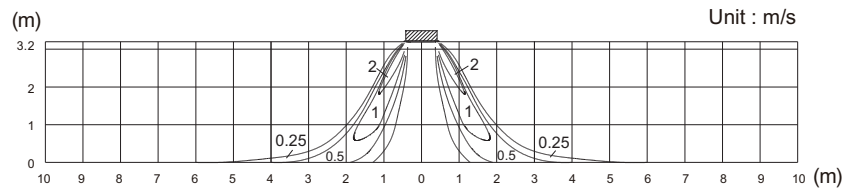

Side view
Vertical airflow direction louver: Special upward

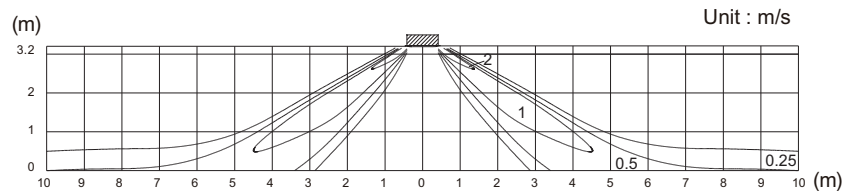

Model: AUHG30LRLE (3-way air outlet)

Measuring conditions	Fan speed	Operation mode	Ceiling mode
	HIGH	FAN	STANDARD

Top view
Vertical airflow direction louver: Upward

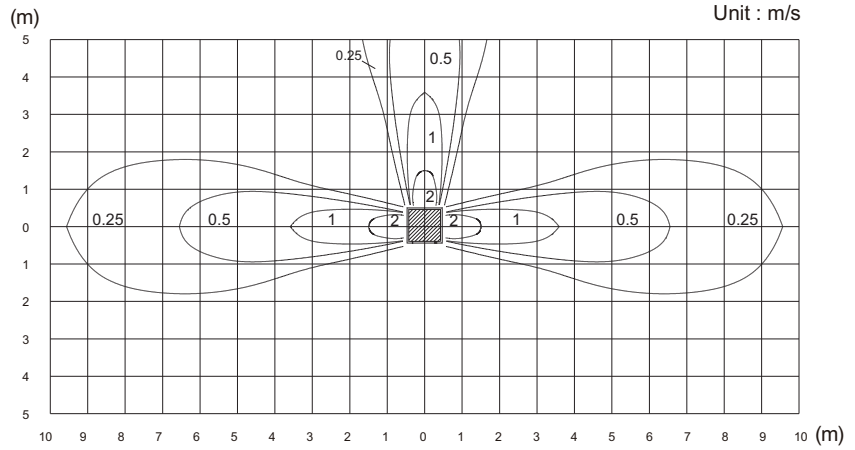

Side view
Vertical airflow direction louver: Upward

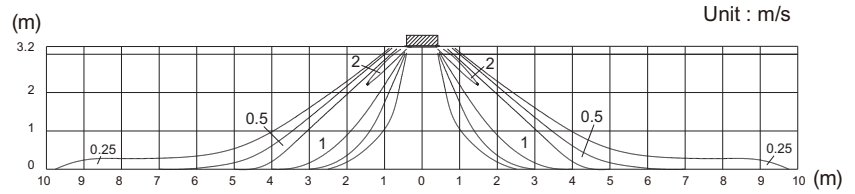

Side view
Vertical airflow direction louver: Downward

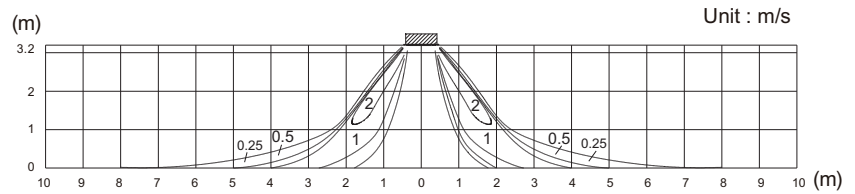

Model: AUHG36LRLE (4-way air outlet)

Measuring conditions	Fan speed	Operation mode	Ceiling mode
	HIGH	FAN	STANDARD

Top view
Vertical airflow direction louver: Upward

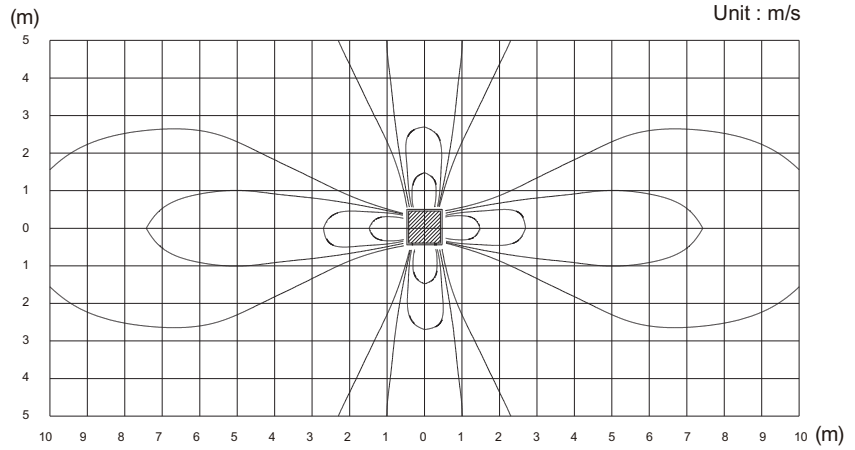

Side view
Vertical airflow direction louver: Upward

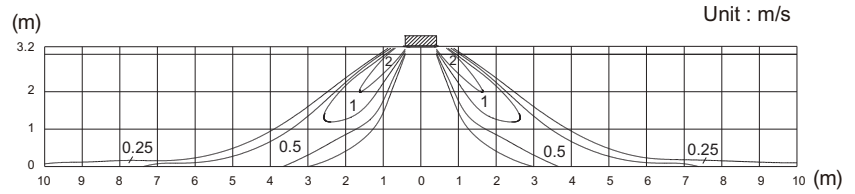

Side view
Vertical airflow direction louver: Downward

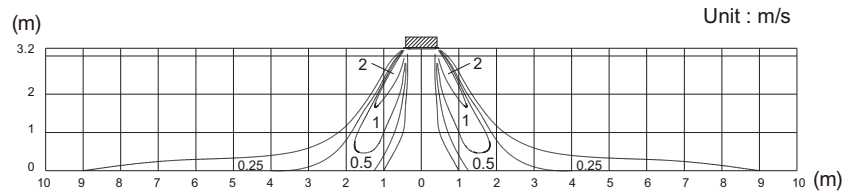

Side view
Vertical airflow direction louver: Special upward

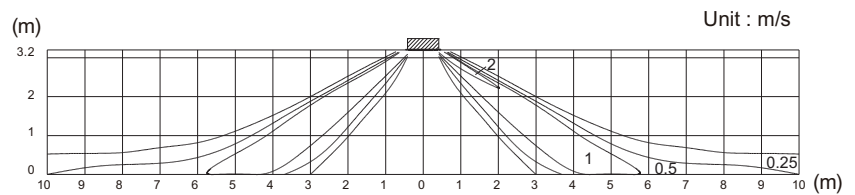

Model: AUHG36LRLE (3-way air outlet)

Measuring conditions	Fan speed	Operation mode	Ceiling mode
	HIGH	FAN	STANDARD

Top view
Vertical airflow direction louver: Upward

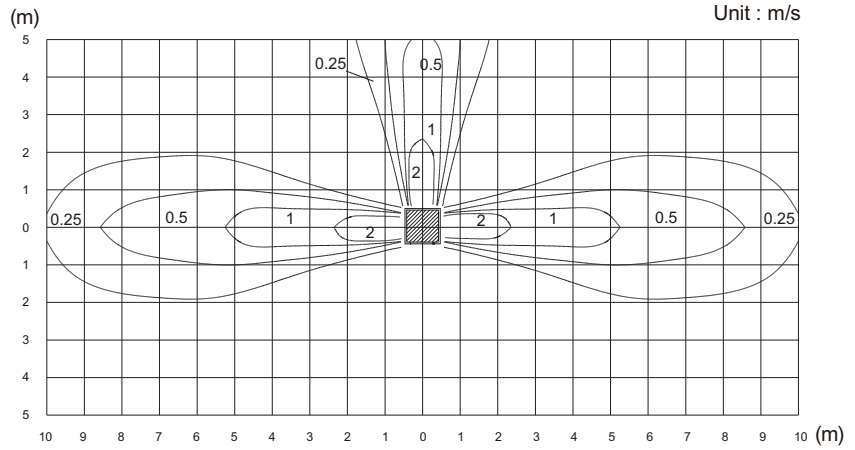

Side view
Vertical airflow direction louver: Upward

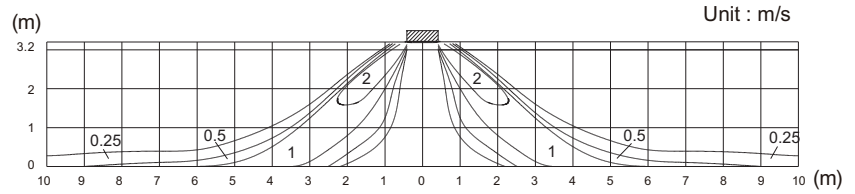

Side view
Vertical airflow direction louver: Downward

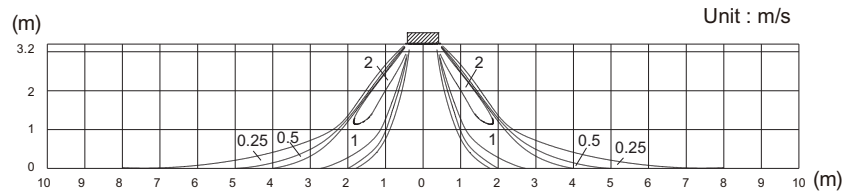

Model: AUHG45LRLA (4-way air outlet)

Measuring conditions	Fan speed	Operation mode	Ceiling mode
	HIGH	FAN	STANDARD

Top view
Vertical airflow direction louver: Upward

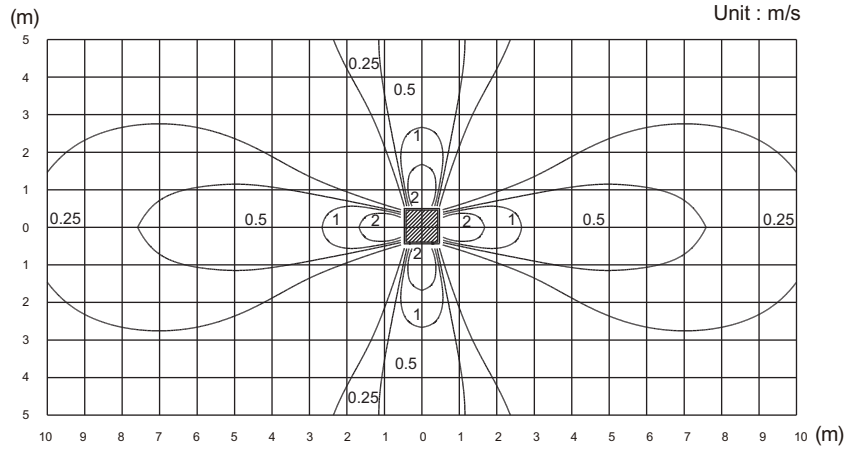

Side view
Vertical airflow direction louver: Upward

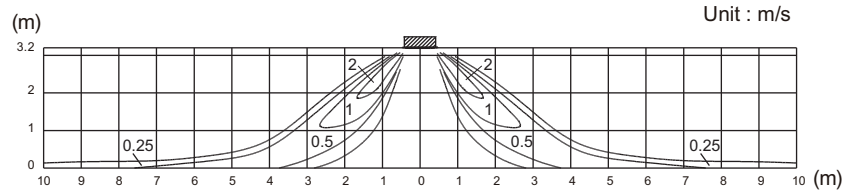

Side view
Vertical airflow direction louver: Downward

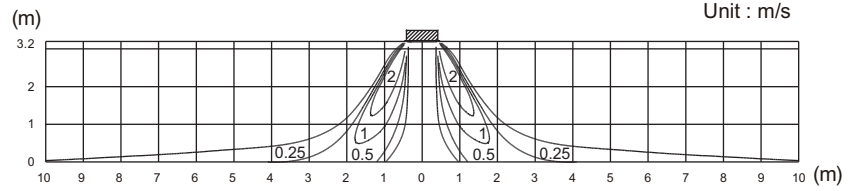

Side view
Vertical airflow direction louver: Special upward

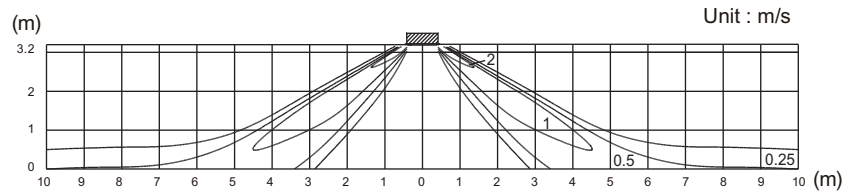

Model: AUHG45LRLA (3-way air outlet)

INDOOR UNITS
SIMULTANEOUS
MULTI

INDOOR UNITS
SIMULTANEOUS
MULTI

Measuring conditions	Fan speed	Operation mode	Ceiling mode
	HIGH	FAN	STANDARD

Top view
Vertical airflow direction louver: Upward

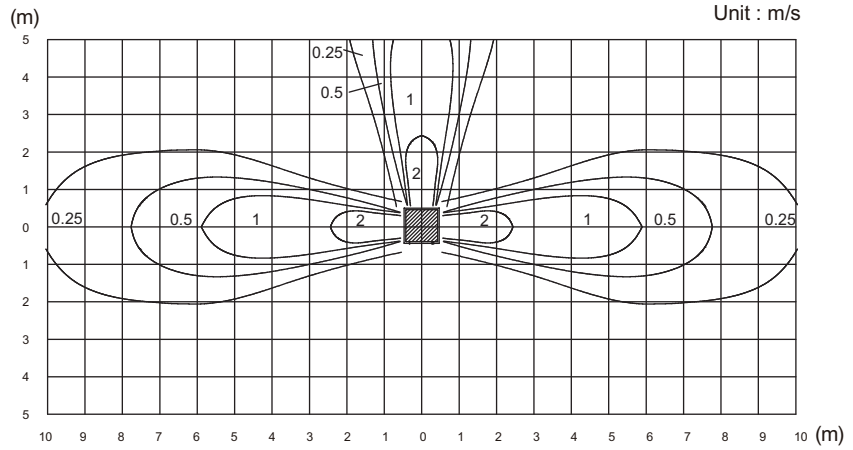

Side view
Vertical airflow direction louver: Upward

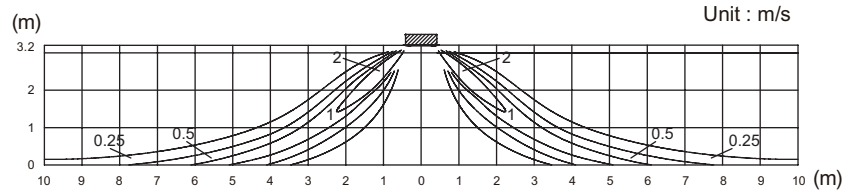

Side view
Vertical airflow direction louver: Downward

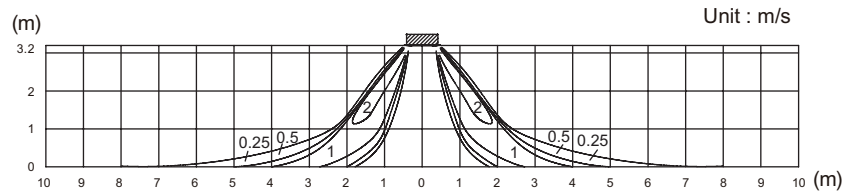

5-3. Slim duct type

Model: ARHG18LLTB

NOTE: This data is measured after installing optional Auto louver grille kit.

- Air velocity distribution

Measuring conditions	Fan speed	Operation mode
	HIGH	FAN

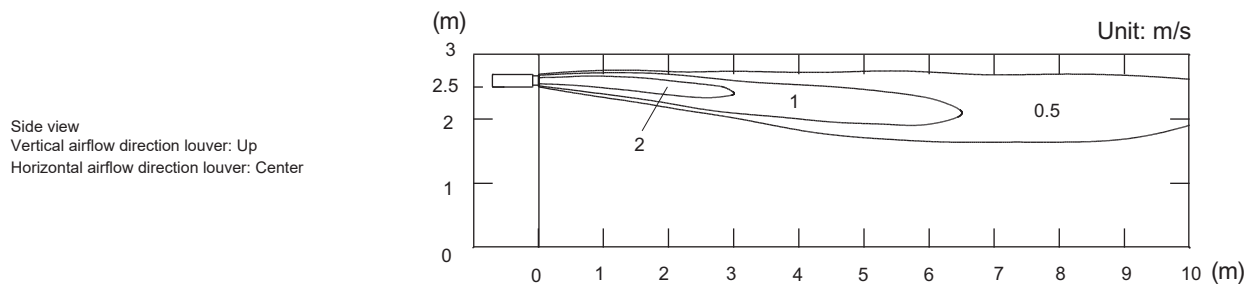
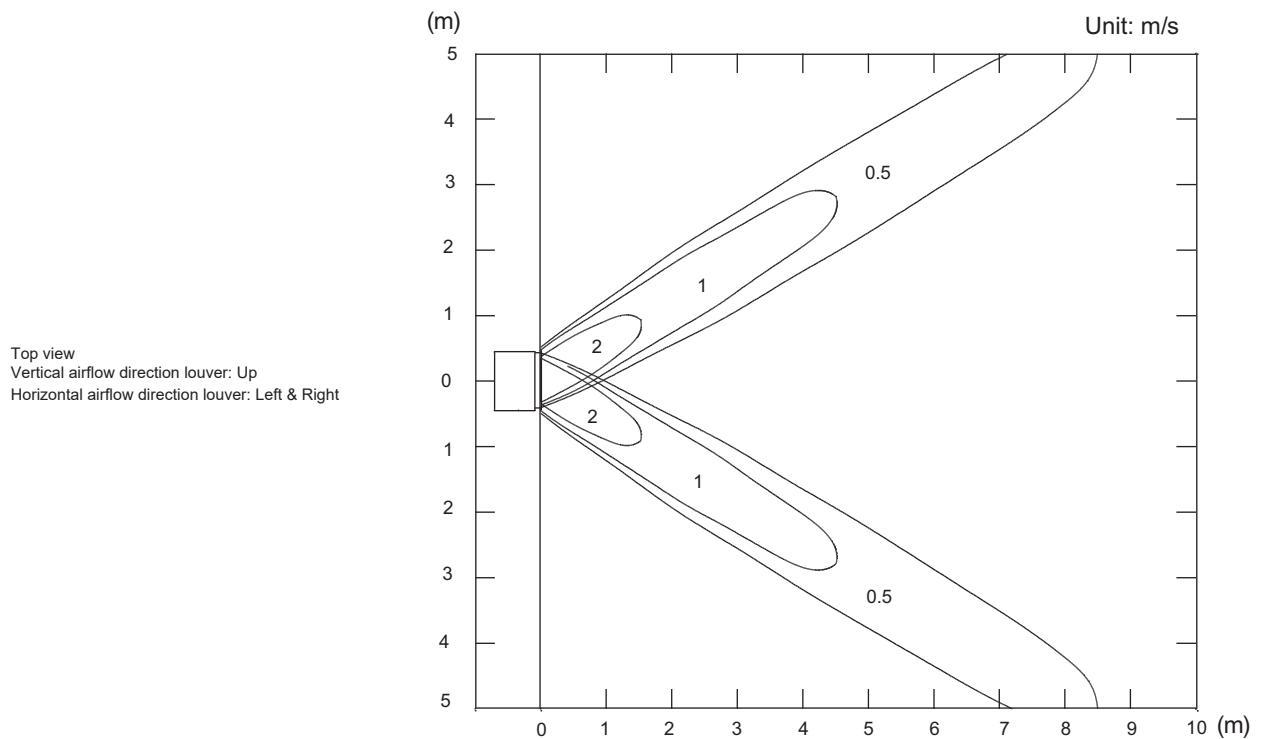
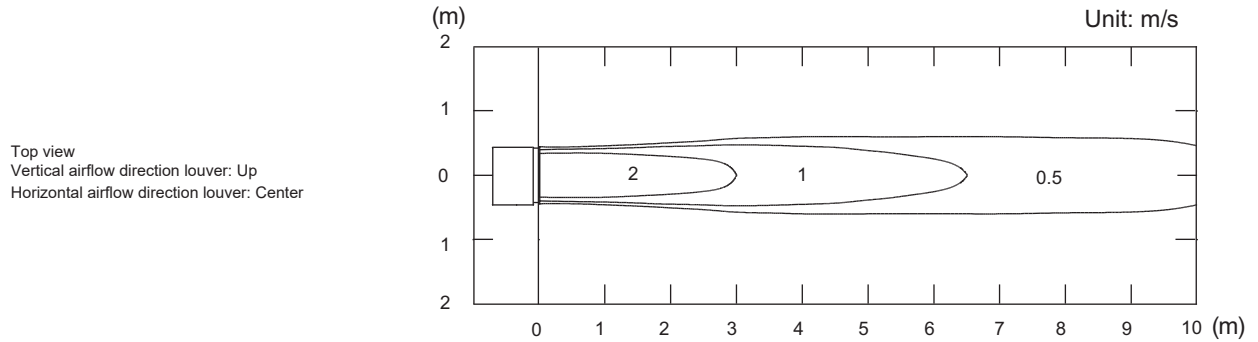

• Air velocity distribution

Measuring conditions	Fan speed	Operation mode
	HIGH	HEAT

Side view
Vertical airflow direction louver: Down
Horizontal airflow direction louver: Center

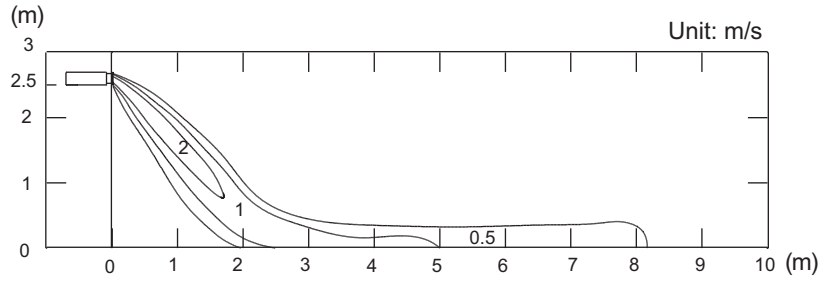

• Air temperature distribution

Measuring conditions	Fan speed	Operation mode
	HIGH	HEAT

Side view
Vertical airflow direction louver: Down
Horizontal airflow direction louver: Center

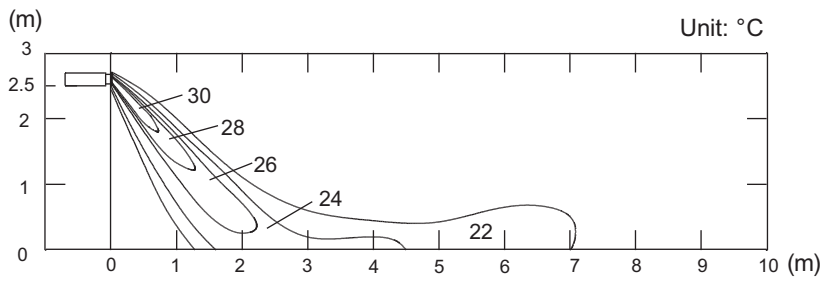

5-4. Floor/Ceiling type

Model: ABHG18LVTB (Under ceiling)

Measuring conditions	Fan speed	Operation mode
	HIGH	FAN

Top view
Vertical airflow direction louver: Up
Horizontal airflow direction louver: Center

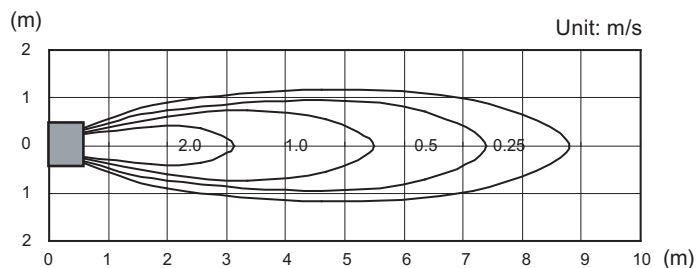

Top view
Vertical airflow direction louver: Up
Horizontal airflow direction louver: Left & Right

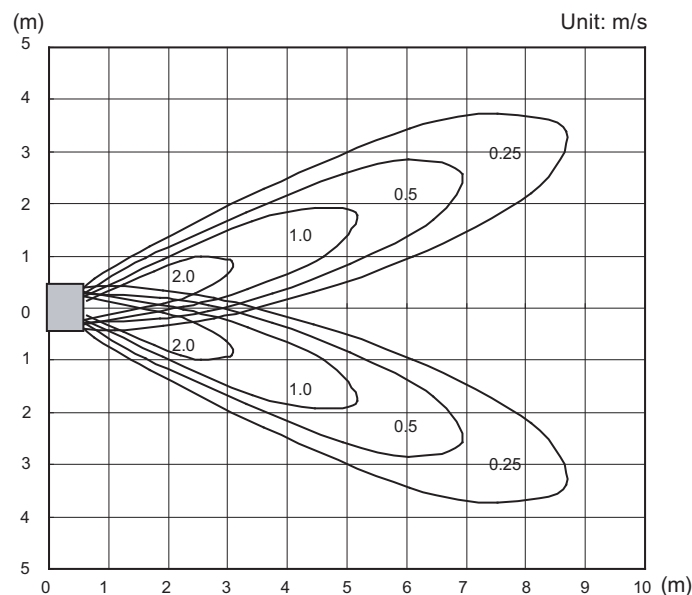

Side view
Vertical airflow direction louver: Up
Horizontal airflow direction louver: Center

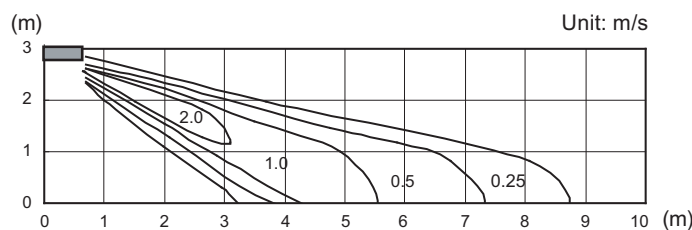

Side view
Vertical airflow direction louver: Center
Horizontal airflow direction louver: Center

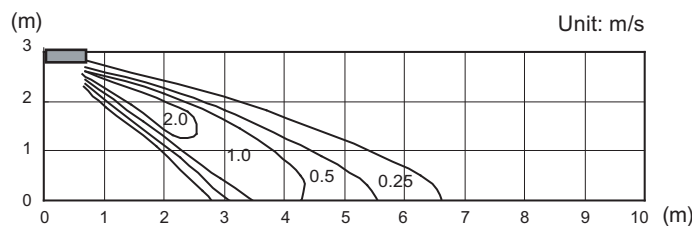

Side view
Vertical airflow direction louver: Down
Horizontal airflow direction louver: Center

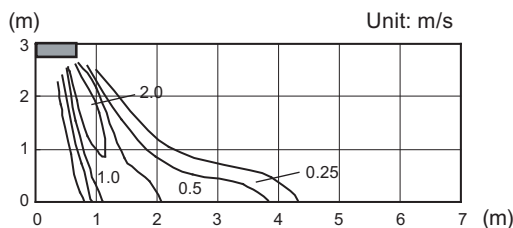

Model: ABHG18LVTB (Floor console)

Measuring conditions	Fan speed	Operation mode
	HIGH	FAN

Top view
Vertical airflow direction louver: Down
Horizontal airflow direction louver: Center

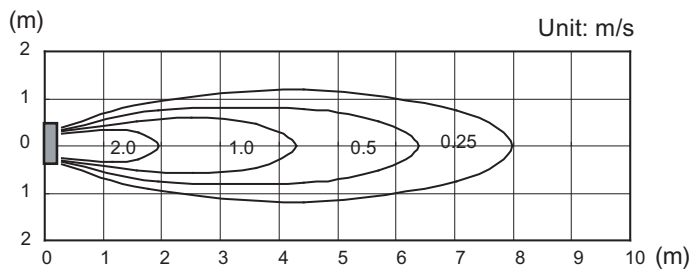

Top view
Vertical airflow direction louver: Down
Horizontal airflow direction louver: Left & Right

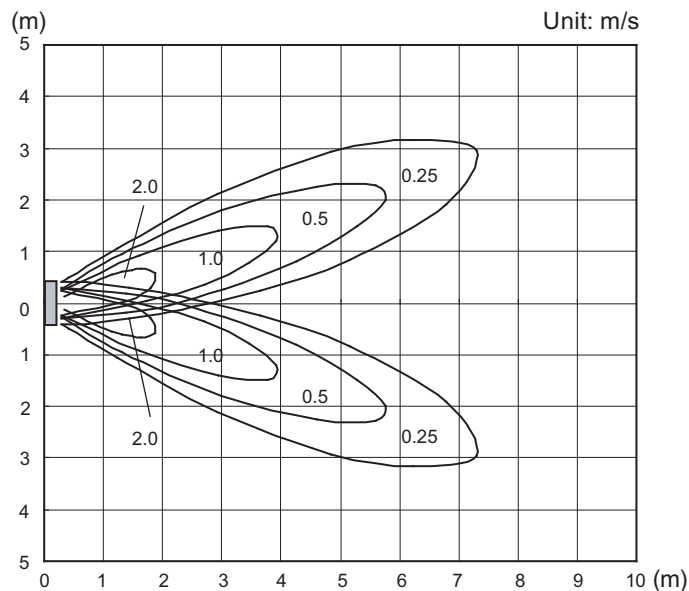

Side view
Vertical airflow direction louver: Down
Horizontal airflow direction louver: Center

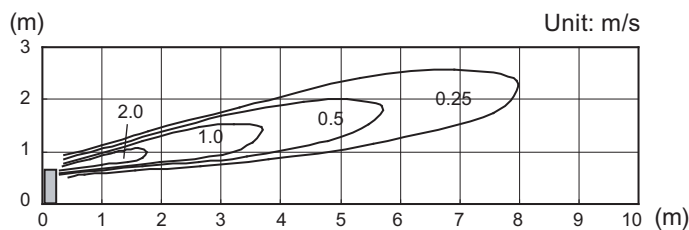

Side view
Vertical airflow direction louver: Center
Horizontal airflow direction louver: Center

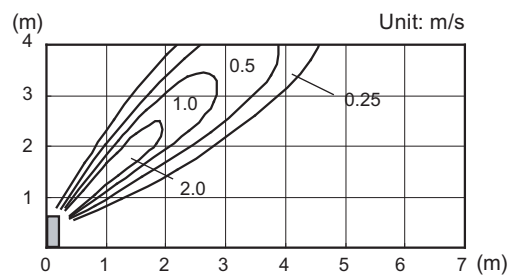

Side view
Vertical airflow direction louver: Up
Horizontal airflow direction louver: Center

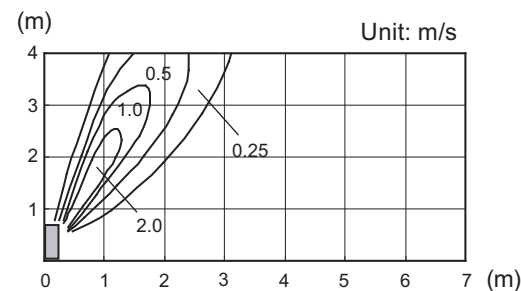

Model: ABHG22LVTA (Under ceiling)

Measuring conditions	Fan speed	Operation mode
	HIGH	FAN

Top view
Vertical airflow direction louver: Up
Horizontal airflow direction louver: Center

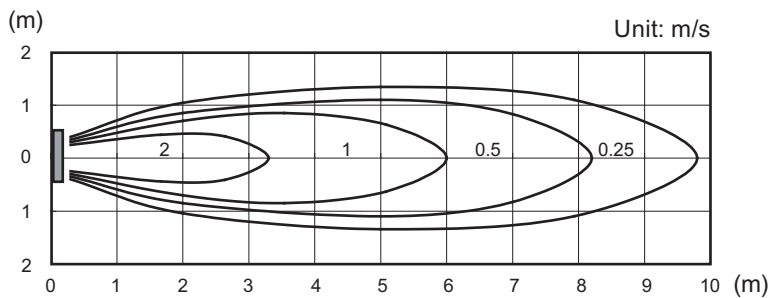

Top view
Vertical airflow direction louver: Up
Horizontal airflow direction louver: Left & Right

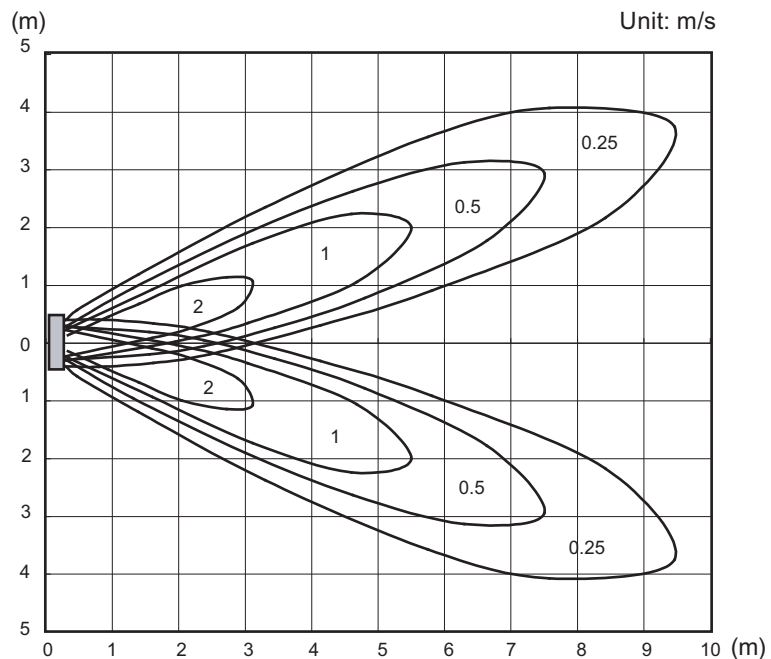

Side view
Vertical airflow direction louver: Up
Horizontal airflow direction louver: Center

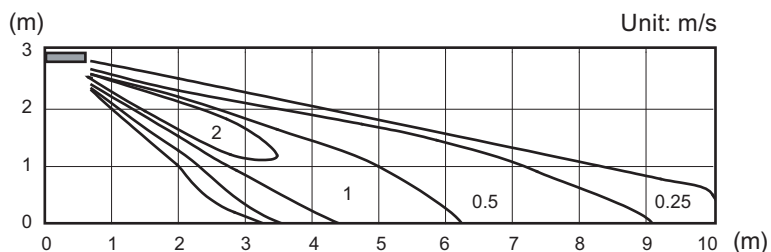

Side view
Vertical airflow direction louver: Center
Horizontal airflow direction louver: Center

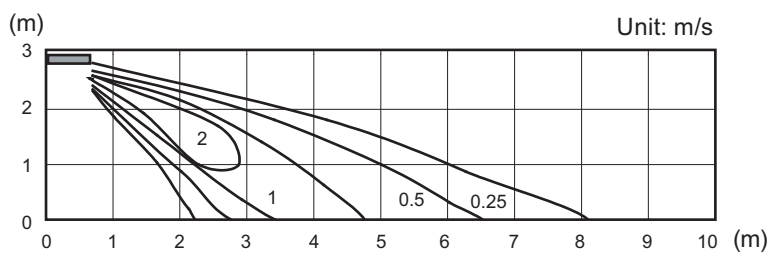

Side view
Vertical airflow direction louver: Down
Horizontal airflow direction louver: Center

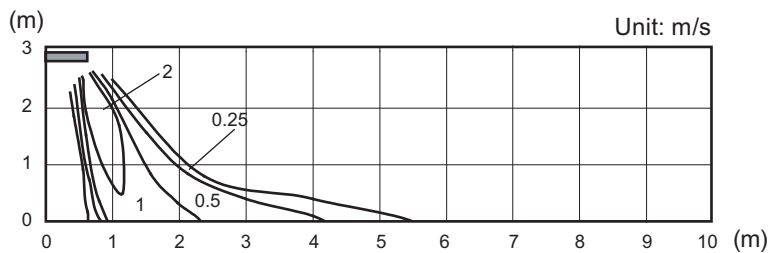

Model: ABHG22LVTA (Floor console)

Measuring conditions	Fan speed	Operation mode
	HIGH	FAN

Top view
Vertical airflow direction louver: Down
Horizontal airflow direction louver: Center

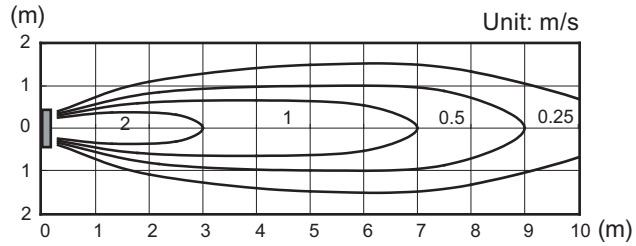

Top view
Vertical airflow direction louver: Down
Horizontal airflow direction louver: Left & Right

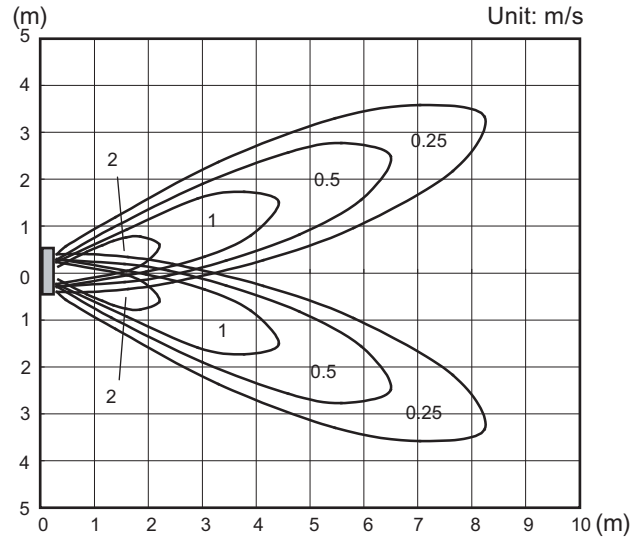

Side view
Vertical airflow direction louver: Down
Horizontal airflow direction louver: Center

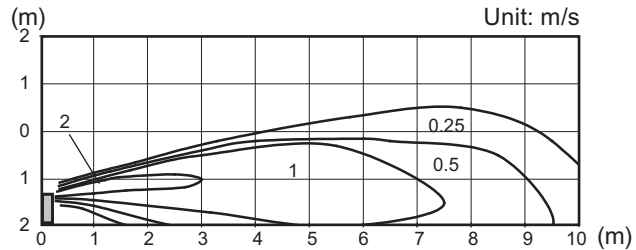

Side view
Vertical airflow direction louver: Center
Horizontal airflow direction louver: Center

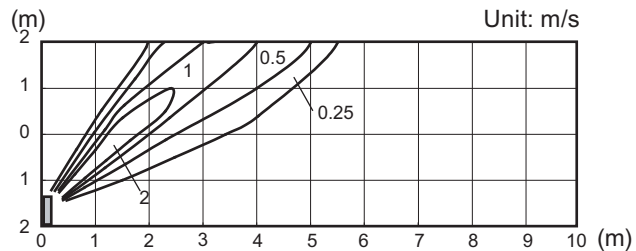

Side view
Vertical airflow direction louver: Up
Horizontal airflow direction louver: Center

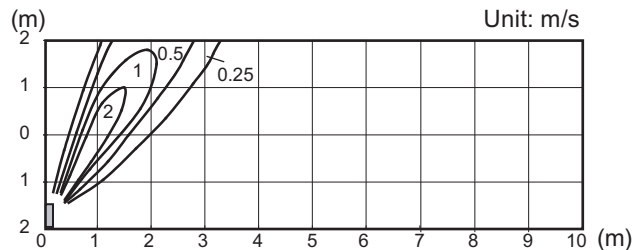

Model: ABHG24LVTA (Under ceiling)

Measuring conditions	Fan speed	Operation mode
	HIGH	FAN

Top view
Vertical airflow direction louver: Up
Horizontal airflow direction louver: Center

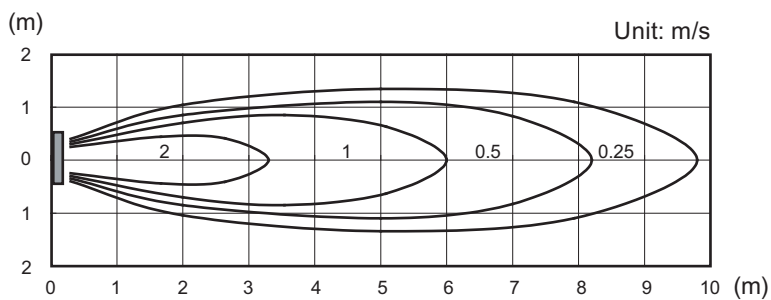

Top view
Vertical airflow direction louver: Up
Horizontal airflow direction louver: Left & Right

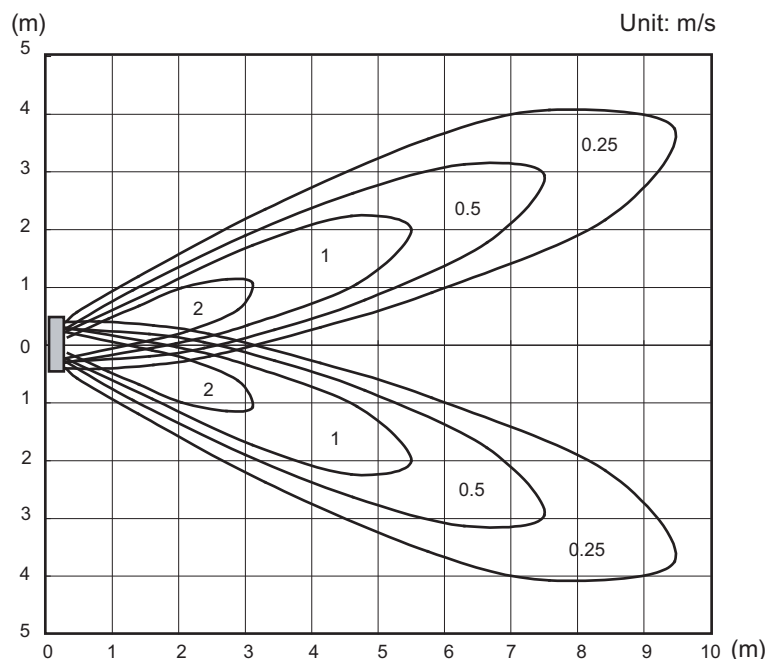

Side view
Vertical airflow direction louver: Up
Horizontal airflow direction louver: Center

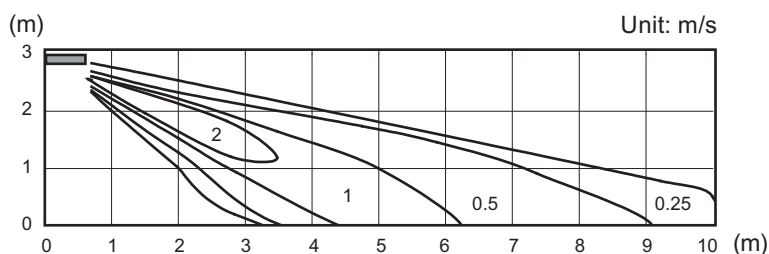

Side view
Vertical airflow direction louver: Center
Horizontal airflow direction louver: Center

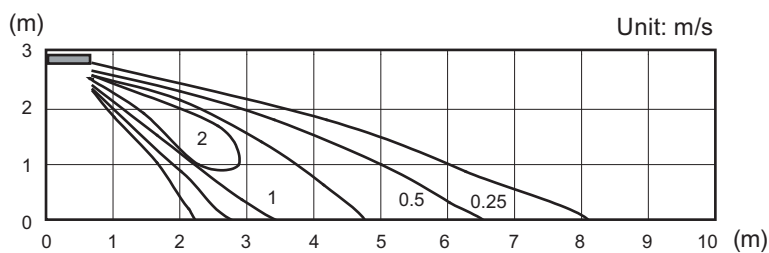

Side view
Vertical airflow direction louver: Down
Horizontal airflow direction louver: Center

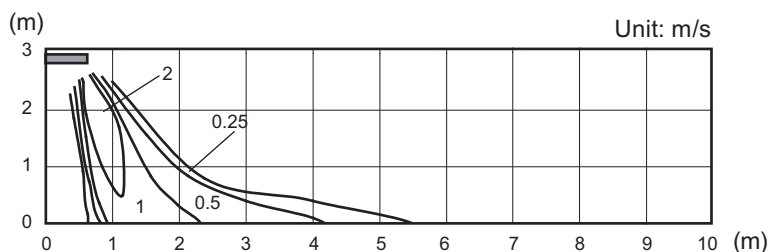

Model: ABHG24LVTA (Floor console)

Measuring conditions	Fan speed	Operation mode
	HIGH	FAN

Top view
Vertical airflow direction louver: Down
Horizontal airflow direction louver: Center

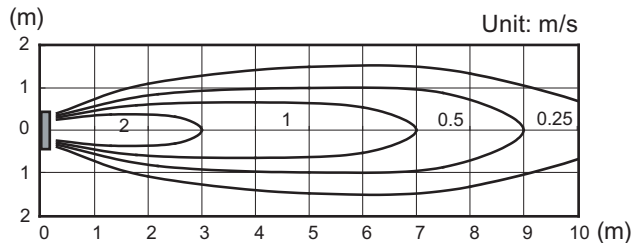

Top view
Vertical airflow direction louver: Down
Horizontal airflow direction louver: Left & Right

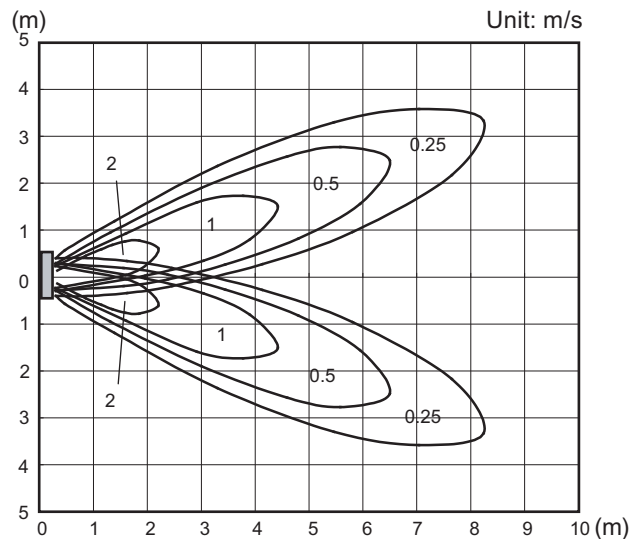

Side view
Vertical airflow direction louver: Down
Horizontal airflow direction louver: Center

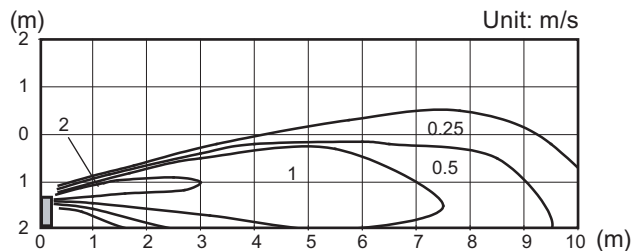

Side view
Vertical airflow direction louver: Center
Horizontal airflow direction louver: Center

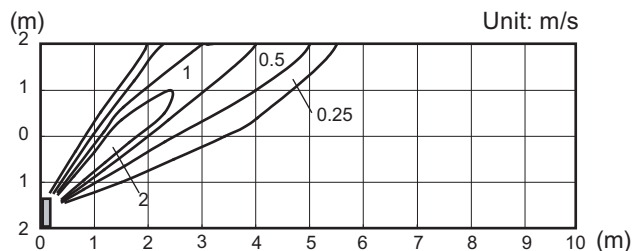

Side view
Vertical airflow direction louver: Up
Horizontal airflow direction louver: Center

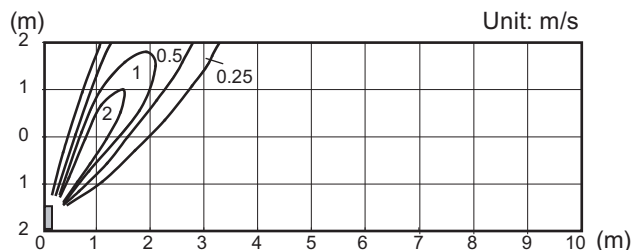

5-5. Ceiling type

Model: ABHG30LRTE

Measuring conditions	Fan speed	Operation mode
	HIGH	FAN

Top view
Vertical airflow direction louver: Up
Horizontal airflow direction louver: Center

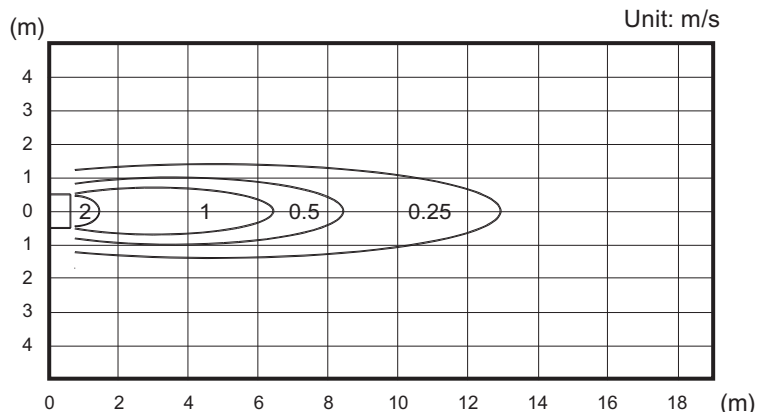

Top view
Vertical airflow direction louver: Up
Horizontal airflow direction louver: Left & Right

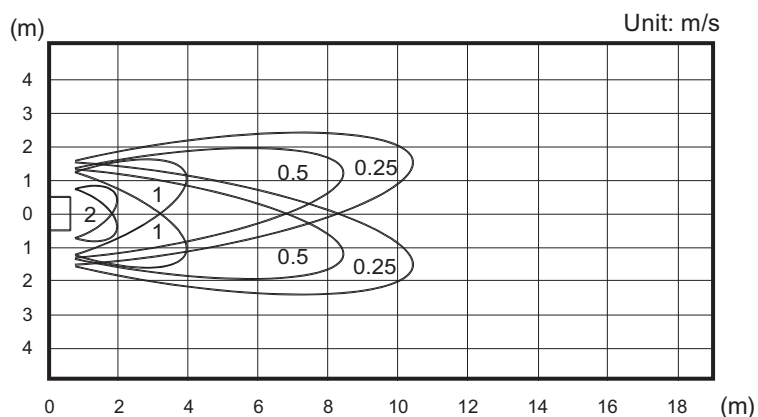

Side view
Vertical airflow direction louver: Up
Horizontal airflow direction louver: Center

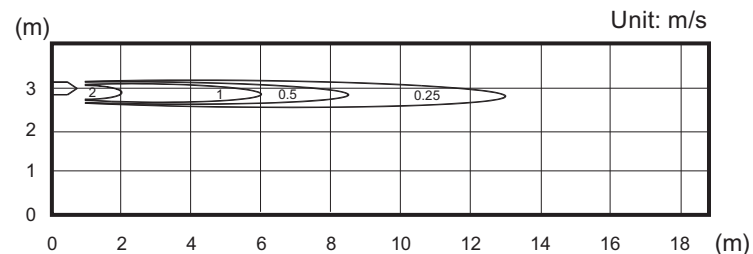

Side view
Vertical airflow direction louver: Center
Horizontal airflow direction louver: Center

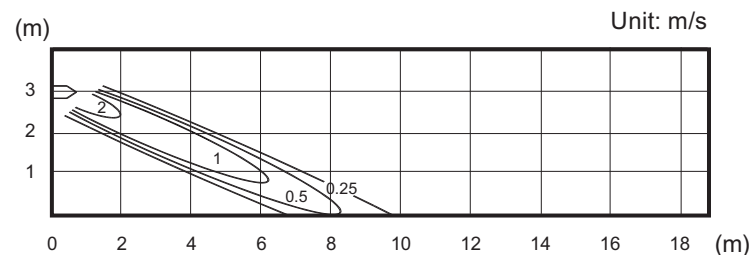

Side view
Vertical airflow direction louver: Down
Horizontal airflow direction louver: Center

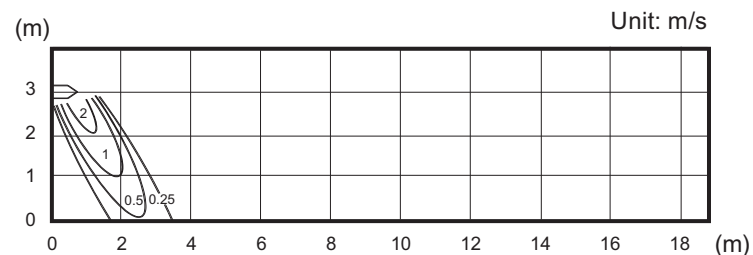

Model: ABHG36LRTE

Measuring conditions	Fan speed	Operation mode
	HIGH	FAN

Top view
Vertical airflow direction louver: Up
Horizontal airflow direction louver: Center

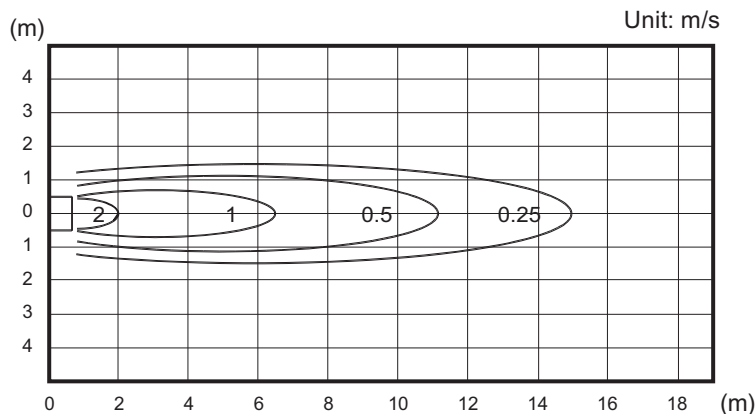

Top view
Vertical airflow direction louver: Up
Horizontal airflow direction louver: Left & Right

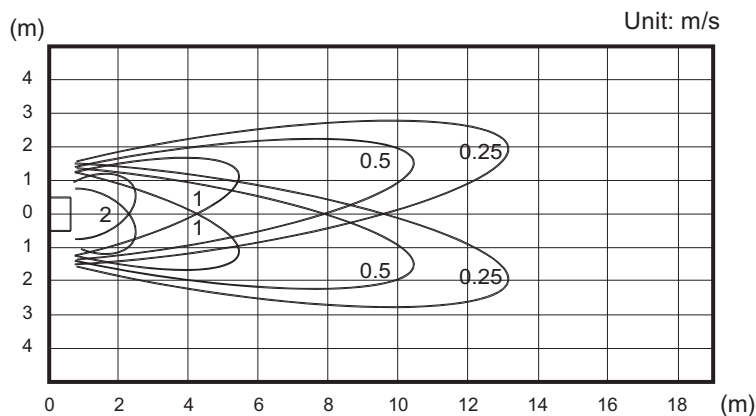

Side view
Vertical airflow direction louver: Up
Horizontal airflow direction louver: Center

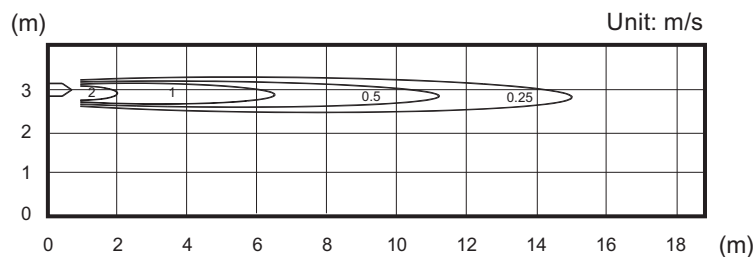

Side view
Vertical airflow direction louver: Center
Horizontal airflow direction louver: Center

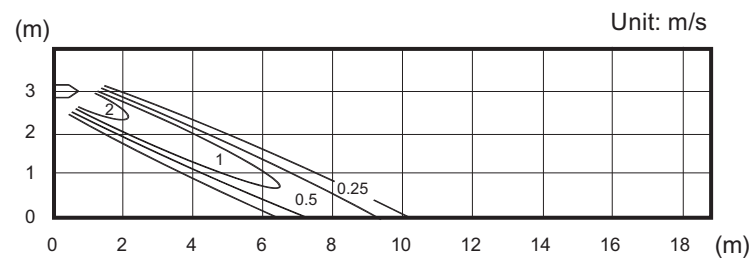

Side view
Vertical airflow direction louver: Down
Horizontal airflow direction louver: Center

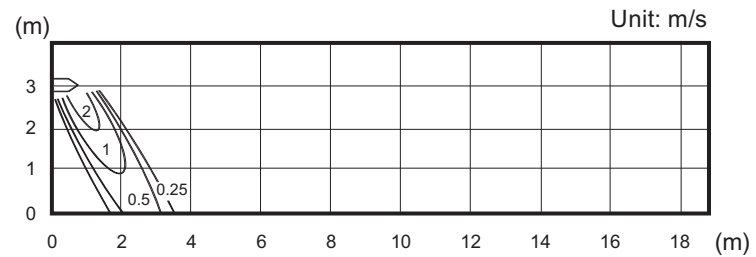

Model: ABHG45LRTA

INDOOR UNITS
SIMULTANEOUS
MULTI

INDOOR UNITS
SIMULTANEOUS
MULTI

Measuring conditions	Fan speed	Operation mode
	HIGH	FAN

Top view
Vertical airflow direction louver: Up
Horizontal airflow direction louver: Center

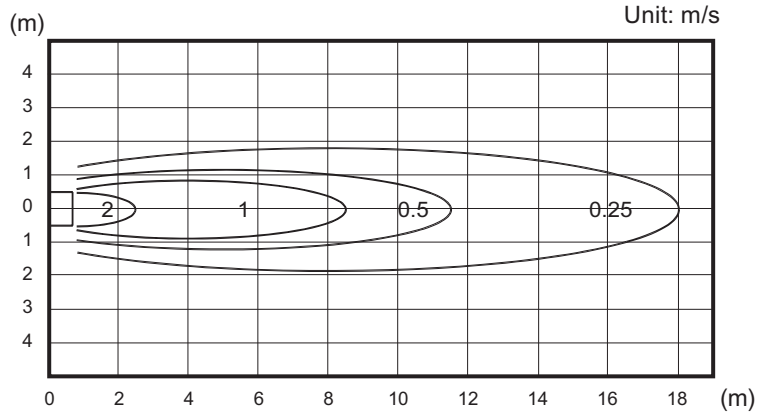

Top view
Vertical airflow direction louver: Up
Horizontal airflow direction louver: Left & Right

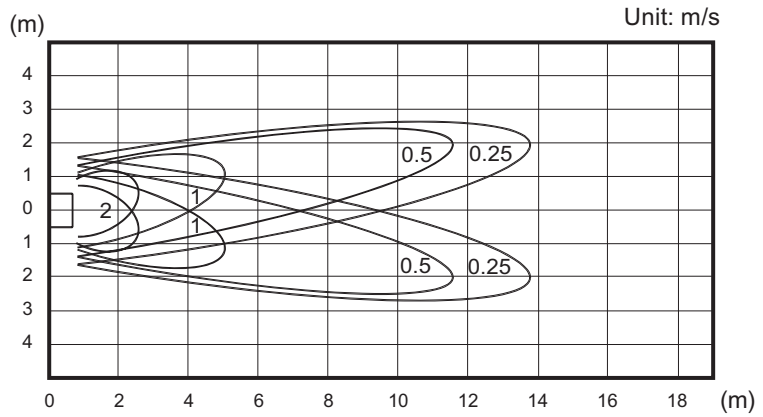

Side view
Vertical airflow direction louver: Up
Horizontal airflow direction louver: Center

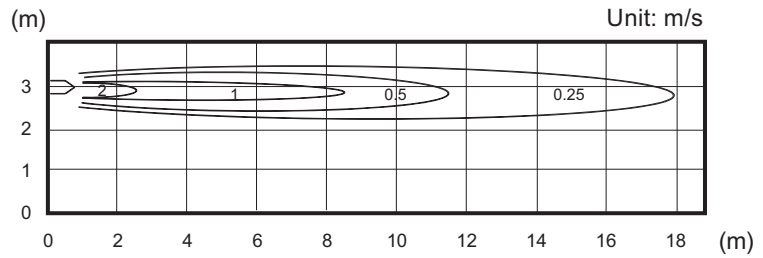

Side view
Vertical airflow direction louver: Center
Horizontal airflow direction louver: Center

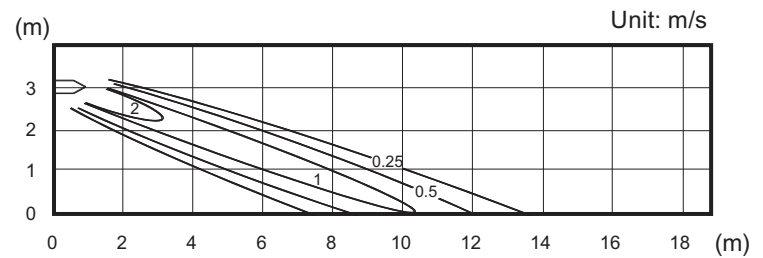

Side view
Vertical airflow direction louver: Down
Horizontal airflow direction louver: Center

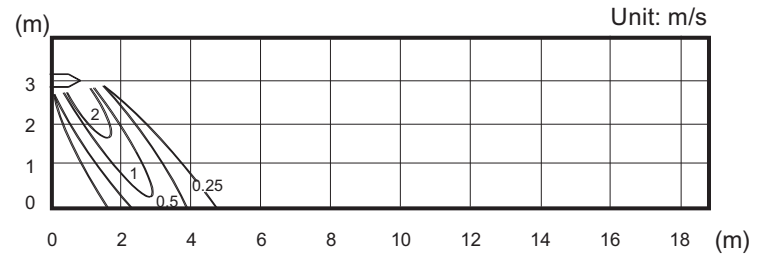

6. Fan performance

NOTE: Airflow and capacity/outlet temperature curve data are measured based on the same conditions mentioned in "Specifications".

6-1. Slim duct type

Model: ARHG18LLTB

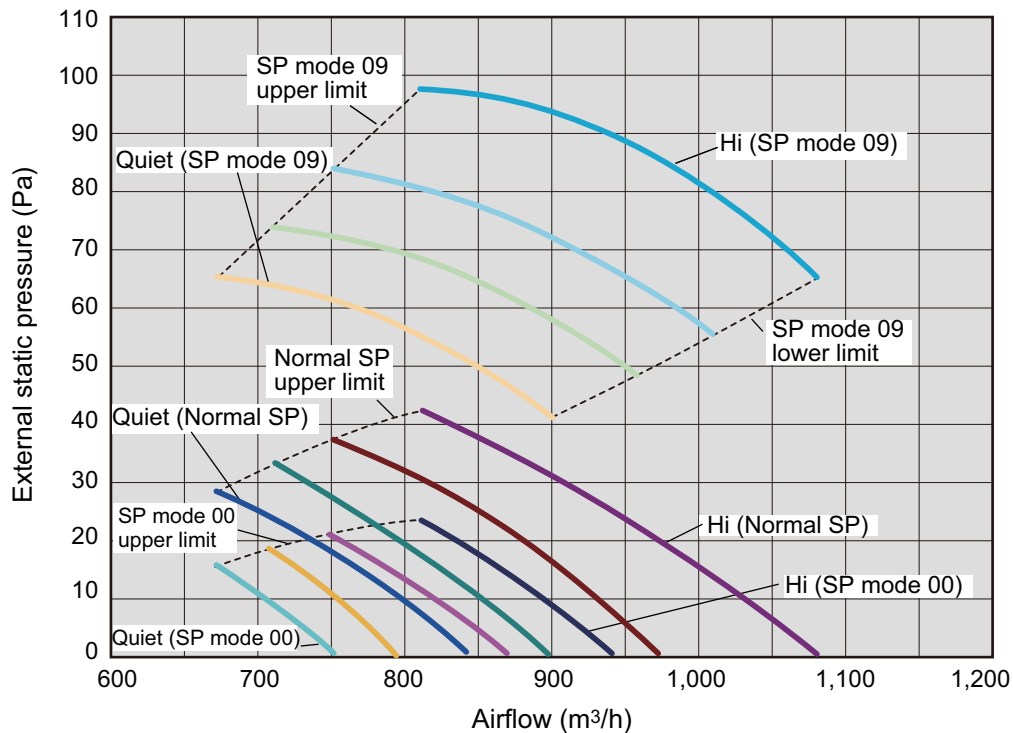

Available airflow rate range (High level)

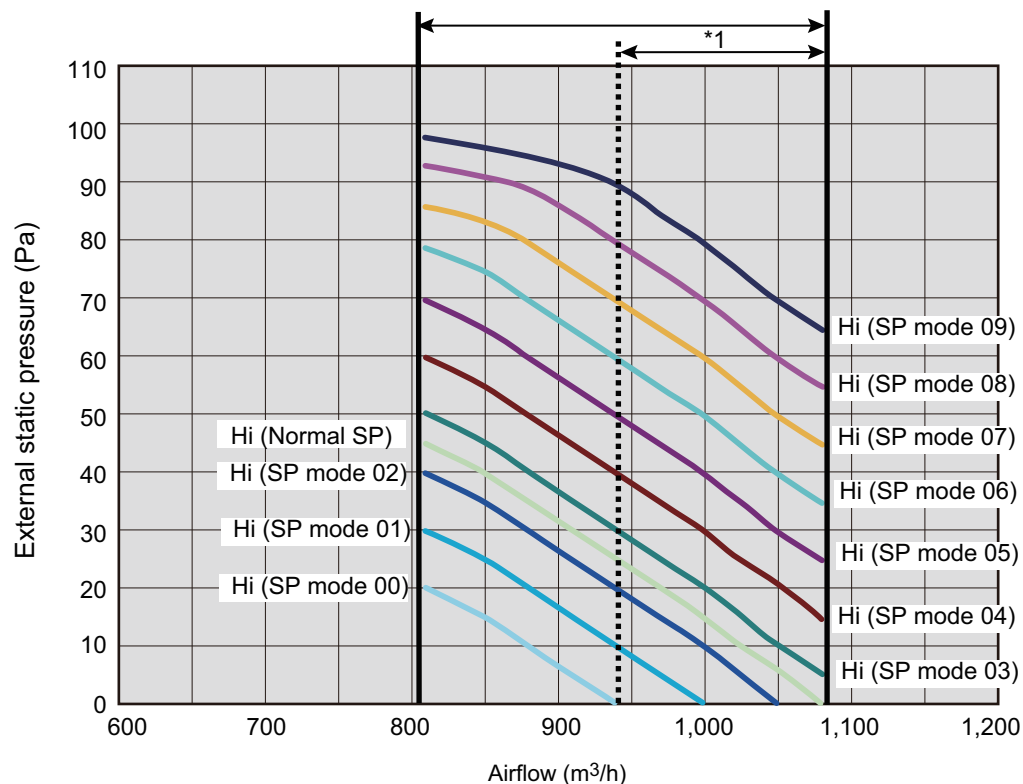

*1: Available airflow rate range when Auto louver grille (option) is installed.
Fan speed: HIGH
Vertical airflow direction louver: Up

● Characteristics of air volume and capacity

• Cooling

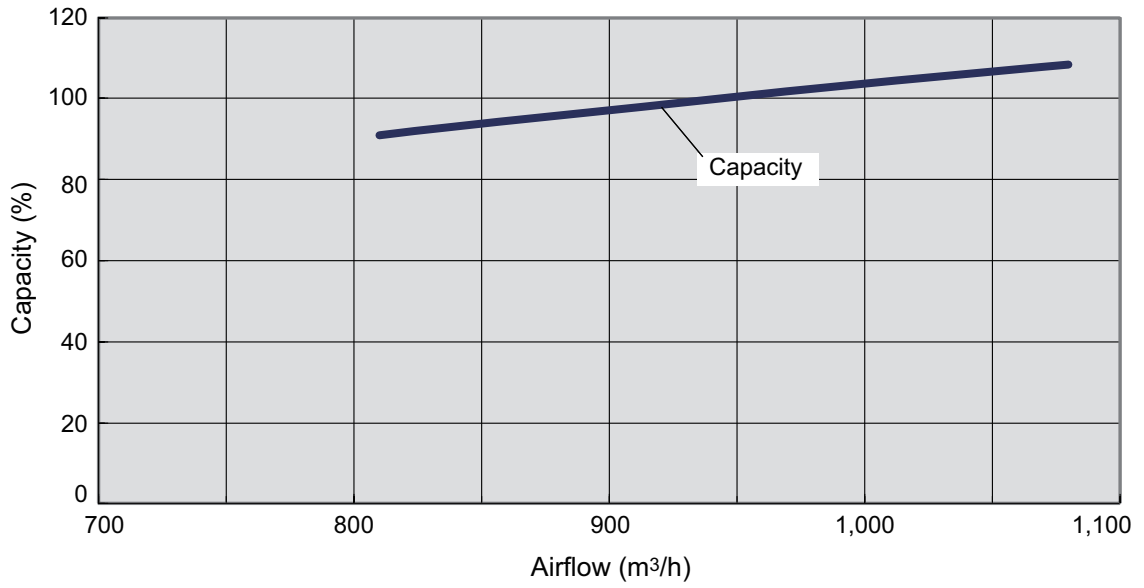

• Heating

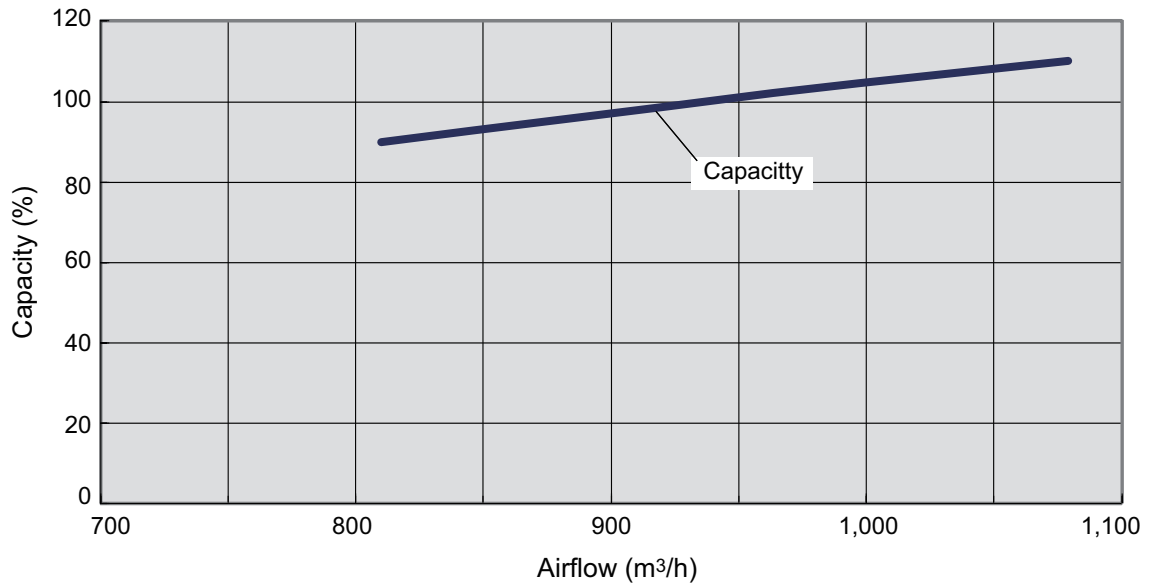

6-2. Duct type

■ Model: ARHG22LMLA (Normal mode)

			Static pressure (Pa)							
			6	11	14	21	25	30	35	40
Fan speed	HIGH	m3/h	—	—	—	—	—	1,200	1,100	1,000
		l/s	—	—	—	—	—	333	306	278
		CFM	—	—	—	—	—	706	647	589
	MED	m3/h	—	—	—	980	915	830	—	—
		l/s	—	—	—	272	254	231	—	—
		CFM	—	—	—	577	539	489	—	—
	LOW	m3/h	—	—	825	690	—	—	—	—
		l/s	—	—	229	192	—	—	—	—
		CFM	—	—	486	406	—	—	—	—
	QUIET	m3/h	630	525	—	—	—	—	—	—
		l/s	175	146	—	—	—	—	—	—
		CFM	371	309	—	—	—	—	—	—

Q-h Characteristic curve

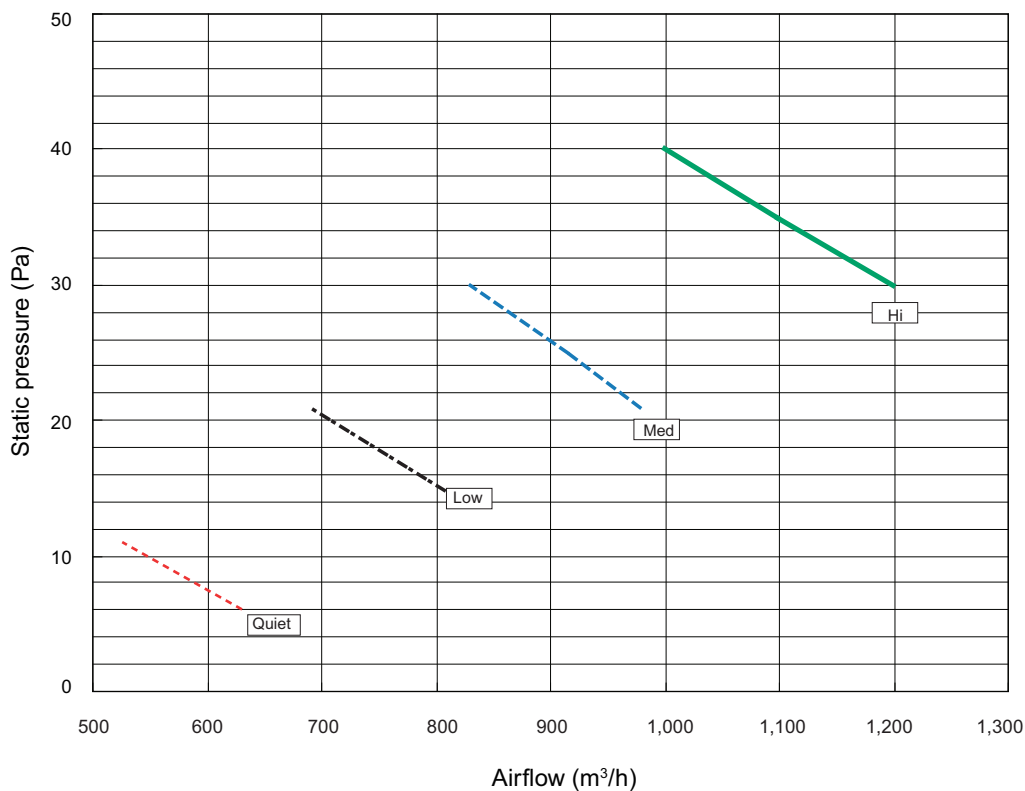

• Cooling

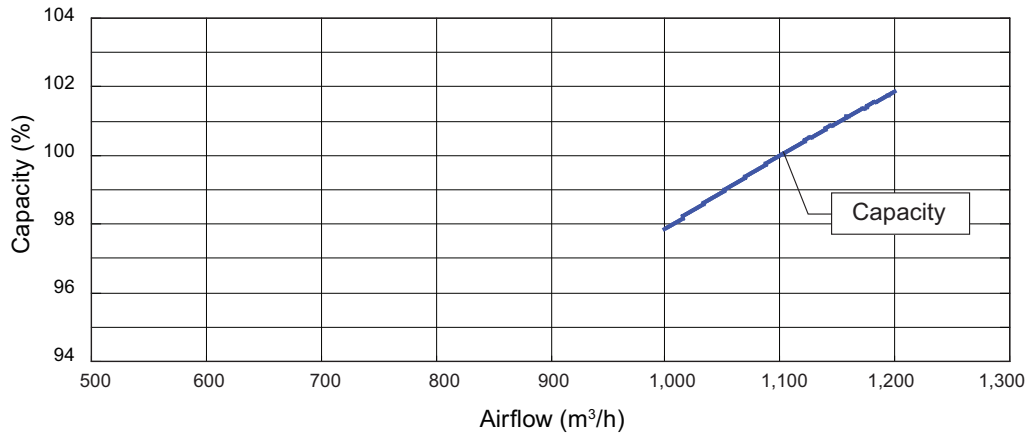

• Heating

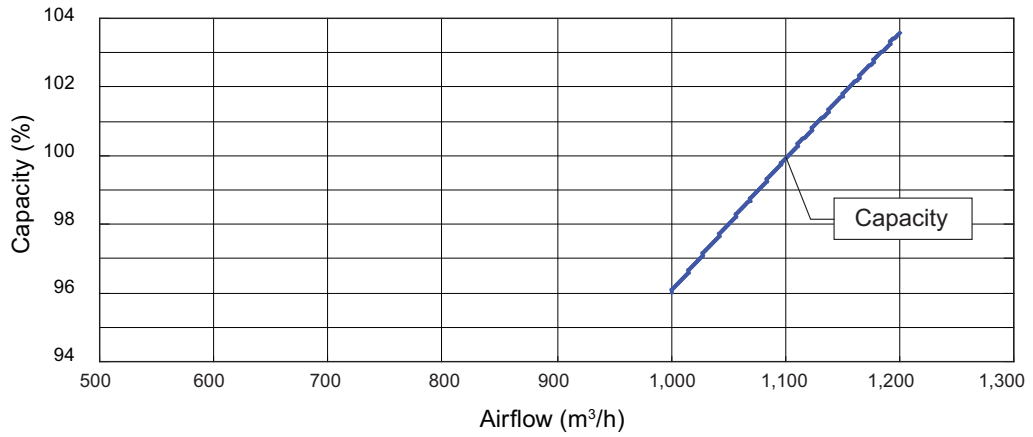

Model: ARHG22LMLA (Static pressure mode 1)

			Static pressure (Pa)							
			20	23	30	35	40	47	55	65
Fan speed	HIGH	m3/h	—	—	—	—	—	—	1,200	1,000
		l/s	—	—	—	—	—	—	333	278
		CFM	—	—	—	—	—	—	706	589
	MED	m3/h	—	—	—	—	1,000	815	—	—
		l/s	—	—	—	—	278	226	—	—
		CFM	—	—	—	—	589	480	—	—
	LOW	m3/h	—	—	830	680	—	—	—	—
		l/s	—	—	231	189	—	—	—	—
		CFM	—	—	489	400	—	—	—	—
	QUIET	m3/h	650	540	—	—	—	—	—	—
		l/s	181	150	—	—	—	—	—	—
		CFM	383	318	—	—	—	—	—	—

Q-h Characteristic curve

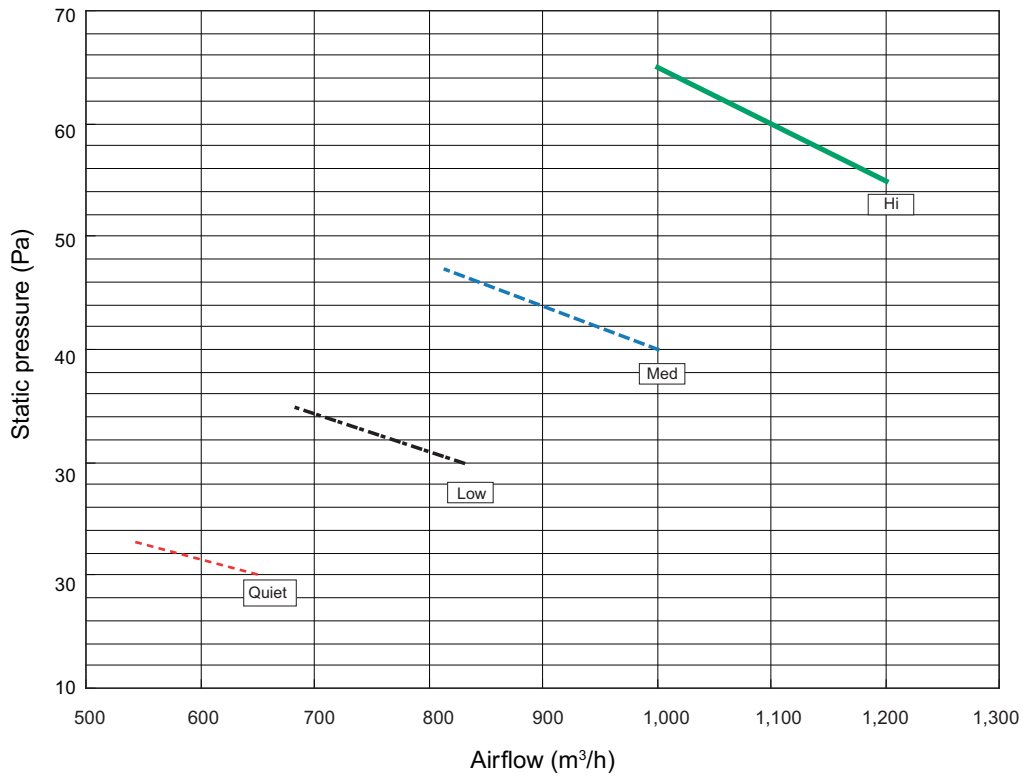

• Cooling

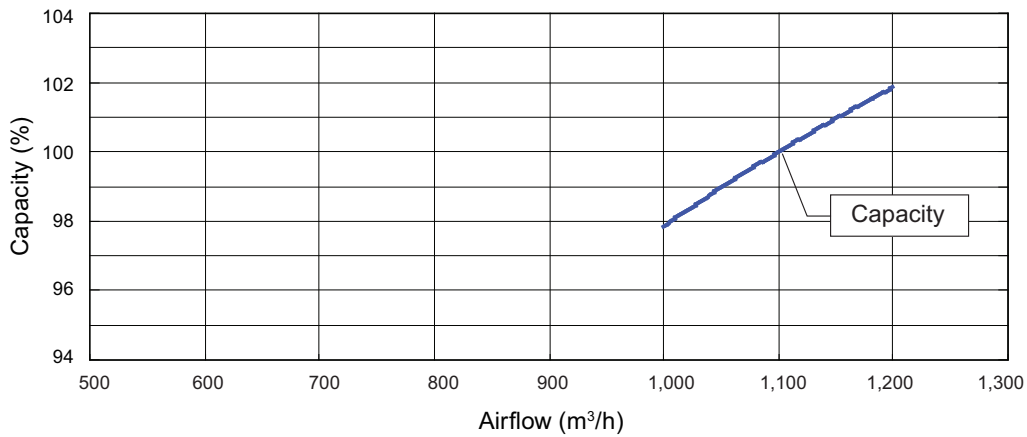

• Heating

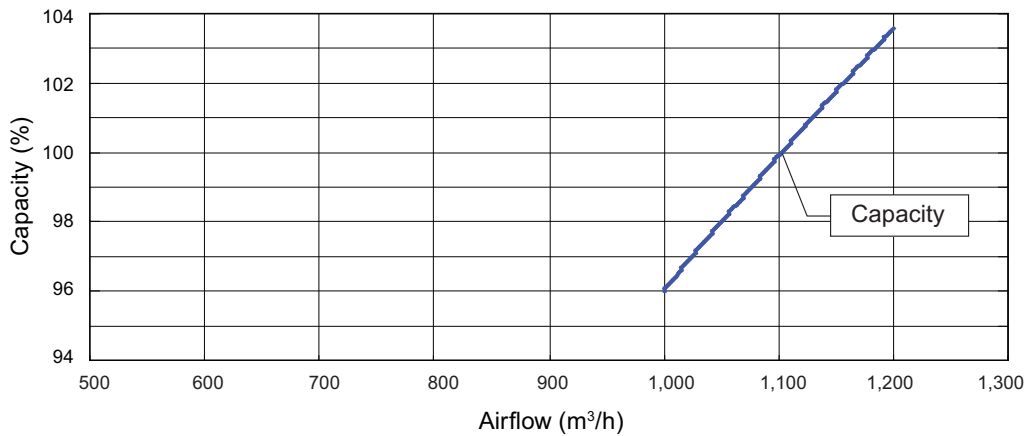

Model: ARHG22LMLA (Static pressure mode 2)

			Static pressure (Pa)							
			35	37	50	55	68	75	93	100
Fan speed	HIGH	m3/h	—	—	—	—	—	—	1,160	930
		l/s	—	—	—	—	—	—	322	258
		CFM	—	—	—	—	—	—	683	547
	MED	m3/h	—	—	—	—	1,020	800	—	—
		l/s	—	—	—	—	283	222	—	—
		CFM	—	—	—	—	600	471	—	—
	LOW	m3/h	—	—	835	670	—	—	—	—
		l/s	—	—	232	186	—	—	—	—
		CFM	—	—	491	394	—	—	—	—
	QUIET	m3/h	660	530	—	—	—	—	—	—
		l/s	183	147	—	—	—	—	—	—
		CFM	388	312	—	—	—	—	—	—

Q-h Characteristic curve

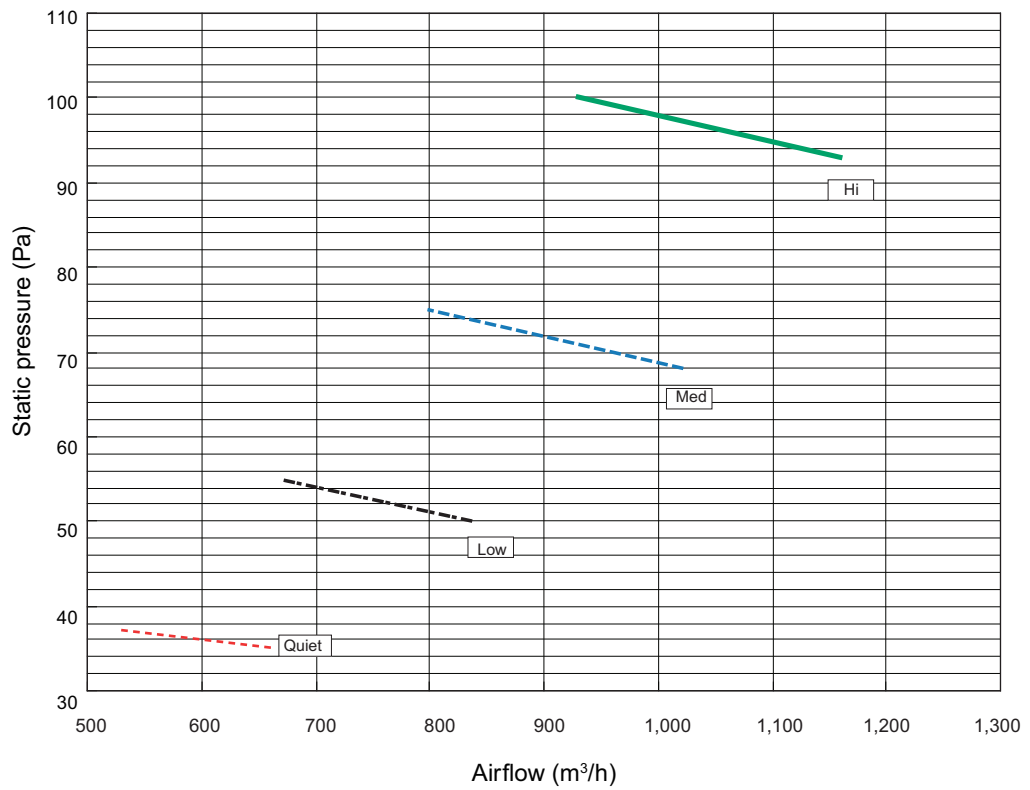

• Cooling

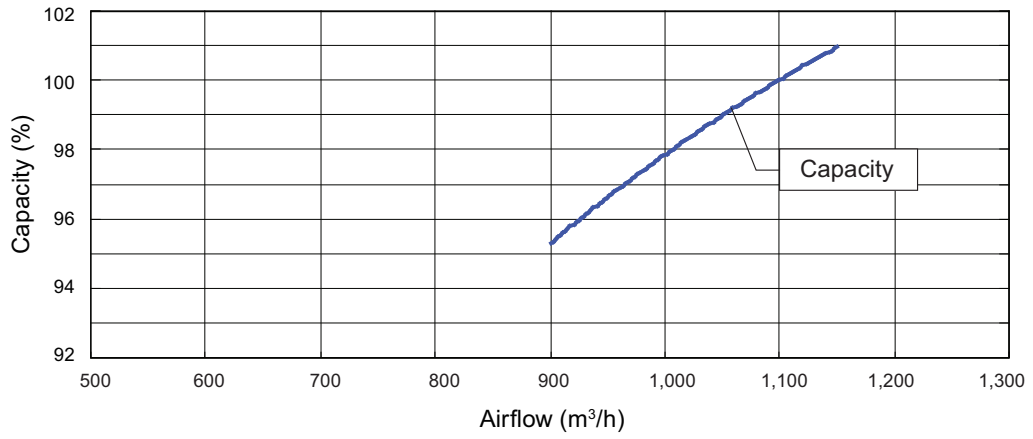

• Heating

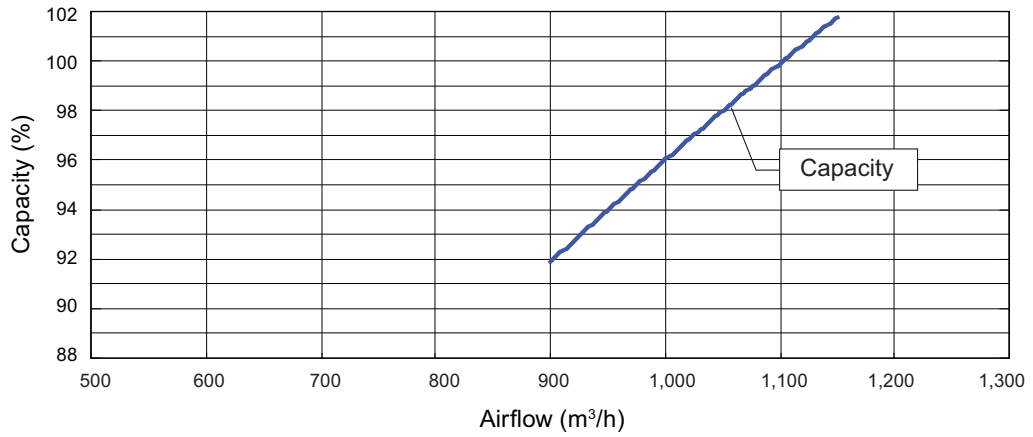

Model: ARHG22LMLA (Static pressure mode 3)

			Static pressure (Pa)							
			55	58	85	90	115	122	142	150
Fan speed	HIGH	m3/h	—	—	—	—	—	—	1,100	880
		l/s	—	—	—	—	—	—	306	244
		CFM	—	—	—	—	—	—	647	518
	MED	m3/h	—	—	—	—	1,000	810	—	—
		l/s	—	—	—	—	278	225	—	—
		CFM	—	—	—	—	589	477	—	—
	LOW	m3/h	—	—	840	680	—	—	—	—
		l/s	—	—	233	189	—	—	—	—
		CFM	—	—	494	400	—	—	—	—
	QUIET	m3/h	660	525	—	—	—	—	—	—
		l/s	183	146	—	—	—	—	—	—
		CFM	388	309	—	—	—	—	—	—

Q-h Characteristic curve

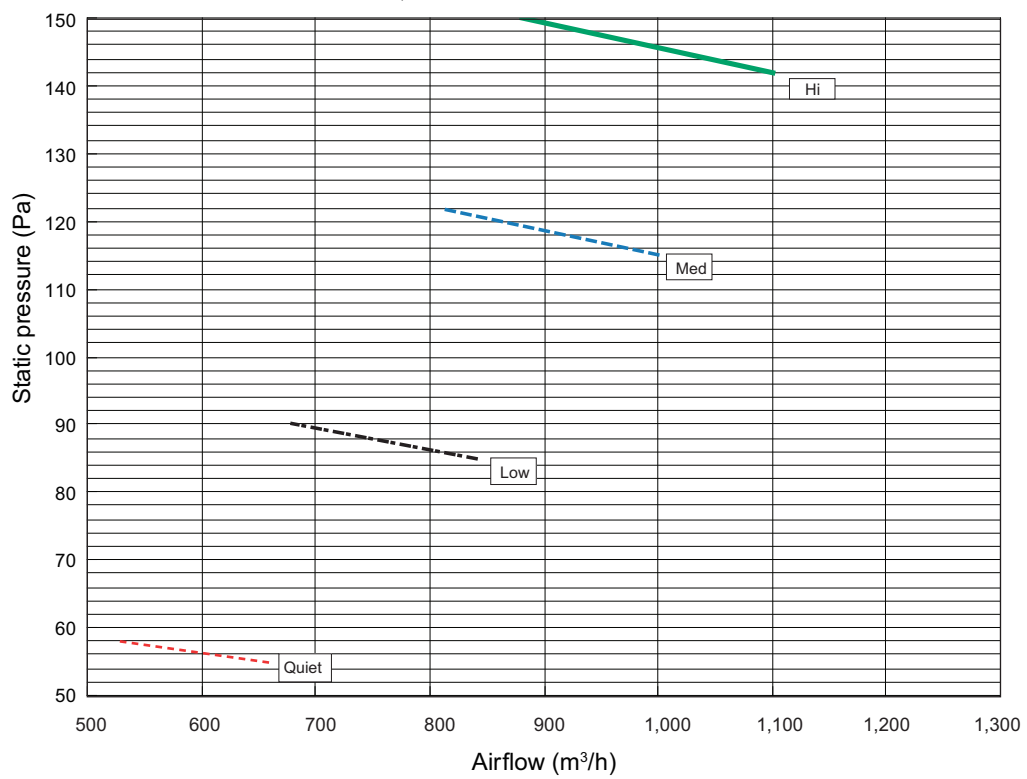

• Cooling

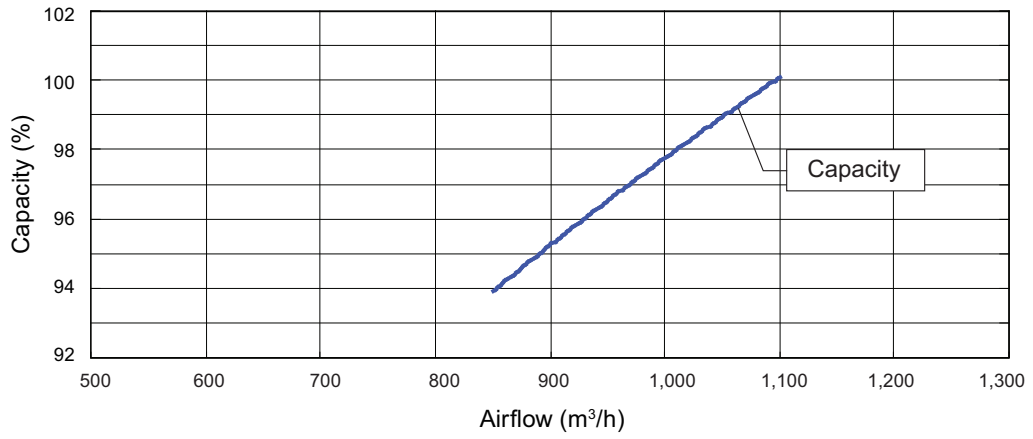

• Heating

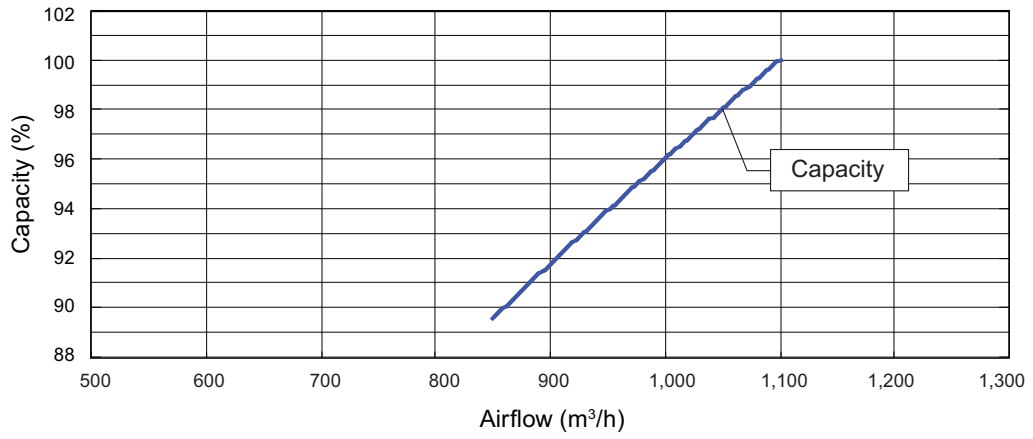

Model: ARHG24LMLA (Normal mode)

			Static pressure (Pa)							
			6	11	14	21	25	30	35	40
Fan speed	HIGH	m3/h	—	—	—	—	—	1,200	1,100	1,000
		l/s	—	—	—	—	—	333	306	278
		CFM	—	—	—	—	—	706	647	589
	MED	m3/h	—	—	—	980	915	830	—	—
		l/s	—	—	—	272	254	231	—	—
		CFM	—	—	—	577	539	489	—	—
	LOW	m3/h	—	—	825	690	—	—	—	—
		l/s	—	—	229	192	—	—	—	—
		CFM	—	—	486	406	—	—	—	—
	QUIET	m3/h	630	525	—	—	—	—	—	—
		l/s	175	146	—	—	—	—	—	—
		CFM	371	309	—	—	—	—	—	—

Q-h Characteristic curve

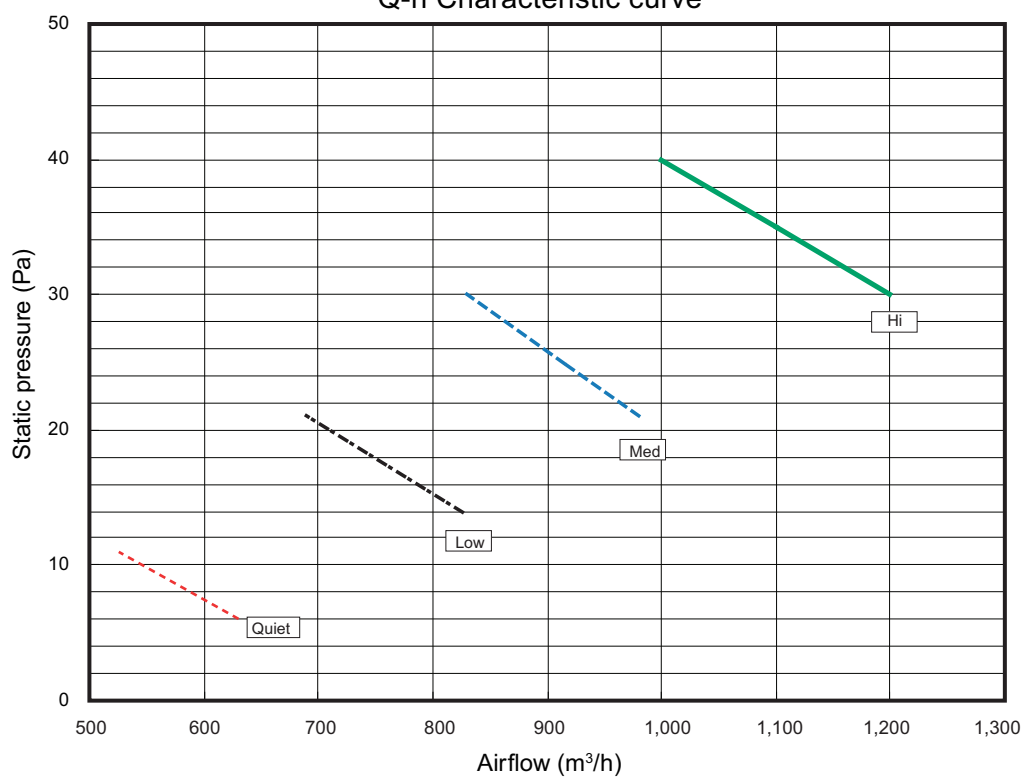

• Cooling

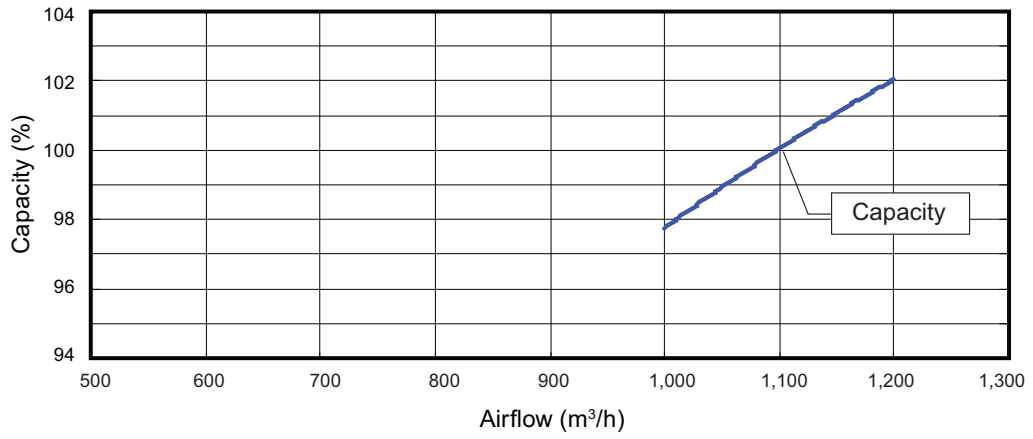

• Heating

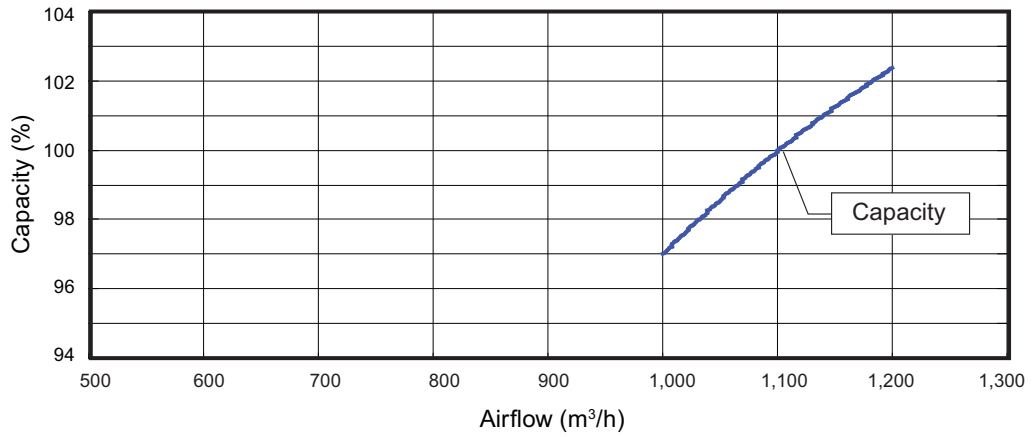

Model: ARHG24LMLA (Static pressure mode 1)

			Static pressure (Pa)							
			20	23	30	35	40	47	55	65
Fan speed	HIGH	m3/h	—	—	—	—	—	—	1,200	1,000
		l/s	—	—	—	—	—	—	333	278
		CFM	—	—	—	—	—	—	706	589
	MED	m3/h	—	—	—	—	1,000	815	—	—
		l/s	—	—	—	—	278	226	—	—
		CFM	—	—	—	—	589	480	—	—
	LOW	m3/h	—	—	830	680	—	—	—	—
		l/s	—	—	231	189	—	—	—	—
		CFM	—	—	489	400	—	—	—	—
	QUIET	m3/h	650	540	—	—	—	—	—	—
		l/s	181	150	—	—	—	—	—	—
		CFM	383	318	—	—	—	—	—	—

Q-h Characteristic curve

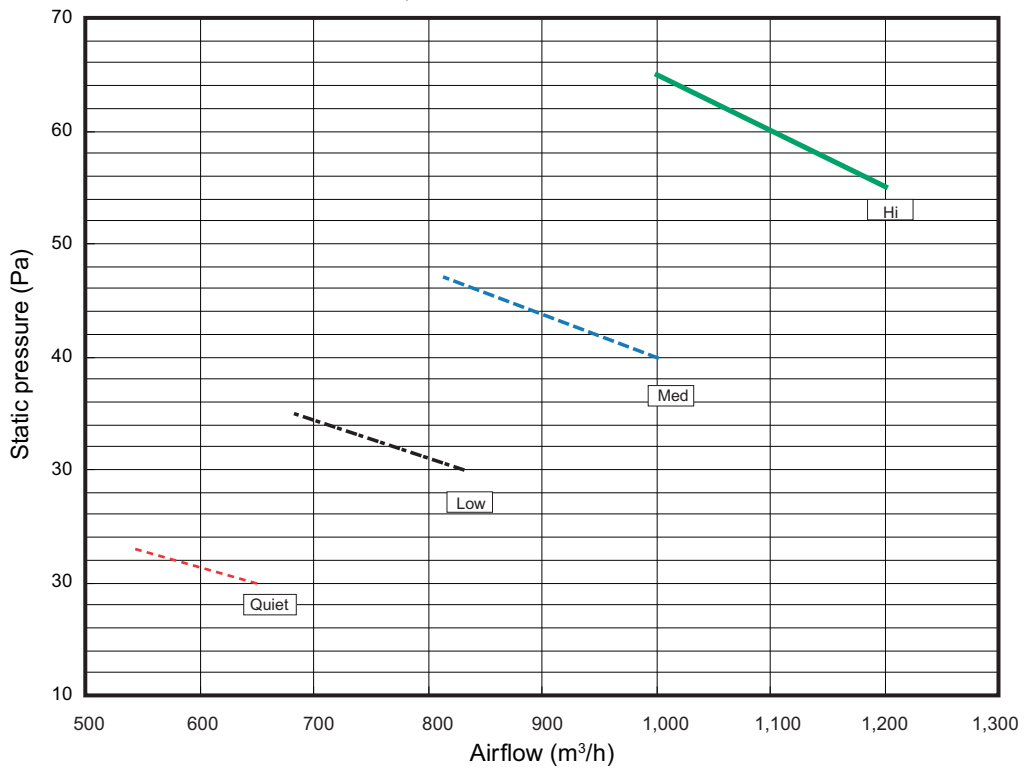

• Cooling

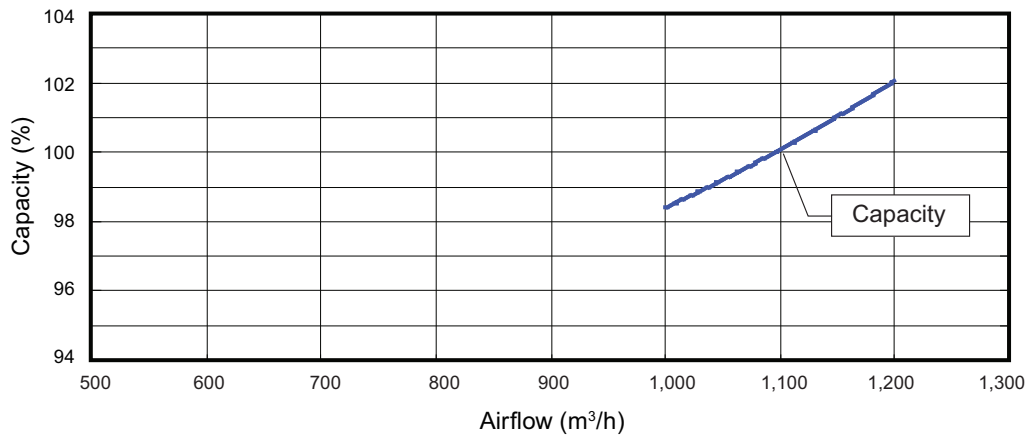

• Heating

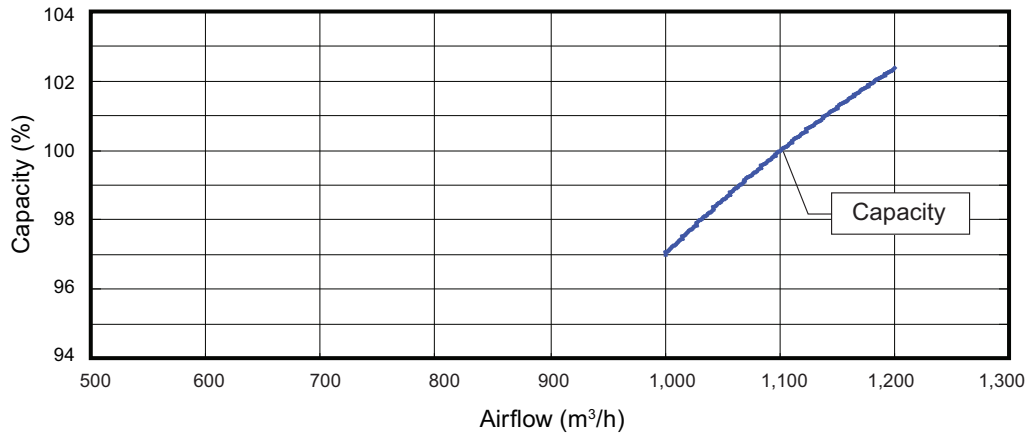

Model: ARHG24LMLA (Static pressure mode 2)

			Static pressure (Pa)							
			35	37	50	55	68	75	93	100
Fan speed	HIGH	m3/h	—	—	—	—	—	—	1,160	930
		l/s	—	—	—	—	—	—	322	258
		CFM	—	—	—	—	—	—	683	547
	MED	m3/h	—	—	—	—	1,020	800	—	—
		l/s	—	—	—	—	283	222	—	—
		CFM	—	—	—	—	600	471	—	—
	LOW	m3/h	—	—	835	670	—	—	—	—
		l/s	—	—	232	186	—	—	—	—
		CFM	—	—	491	394	—	—	—	—
	QUIET	m3/h	660	530	—	—	—	—	—	—
		l/s	183	147	—	—	—	—	—	—
		CFM	388	312	—	—	—	—	—	—

Q-h Characteristic curve

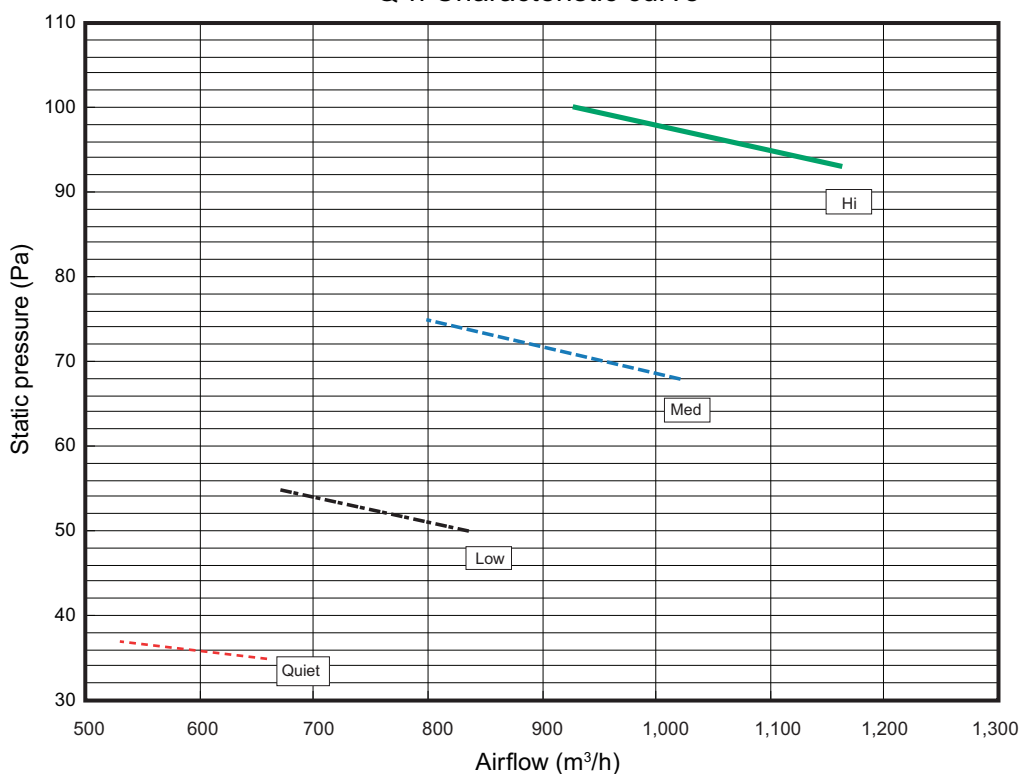

• Cooling

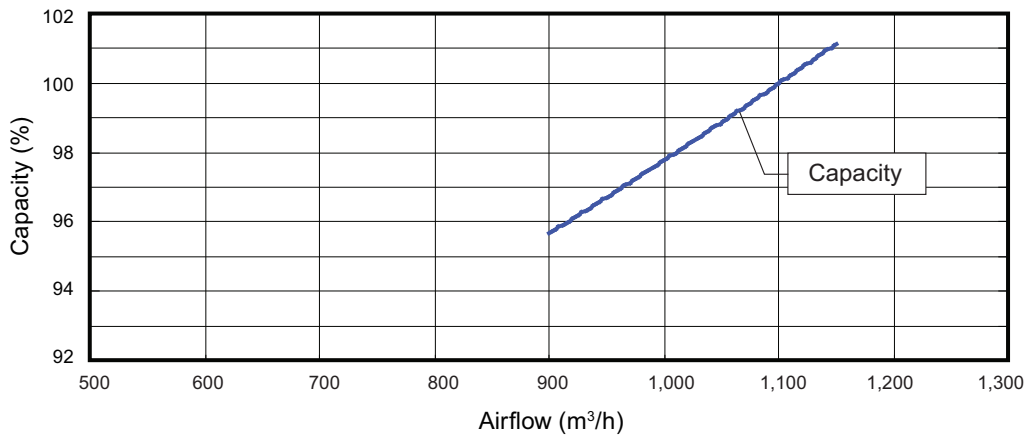

• Heating

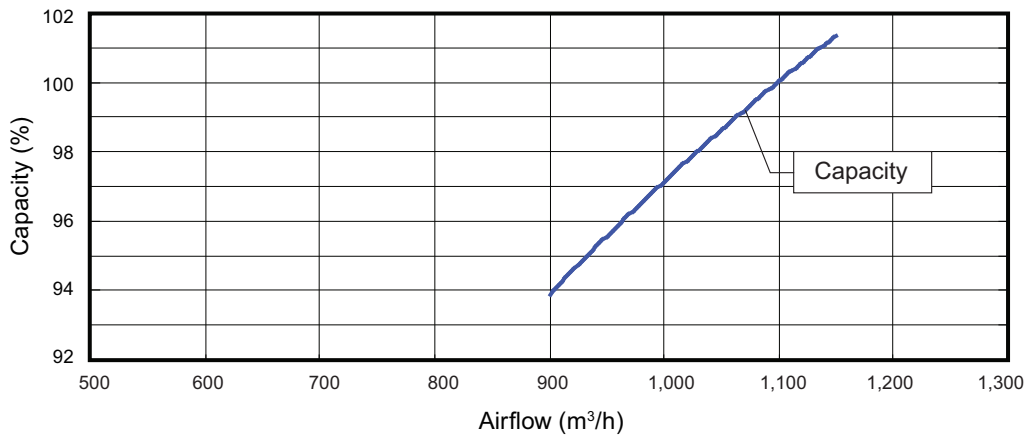

Model: ARHG24LMLA (Static pressure mode 3)

			Static pressure (Pa)							
			55	58	85	90	115	122	142	150
Fan speed	HIGH	m3/h	—	—	—	—	—	—	1,100	880
		l/s	—	—	—	—	—	—	306	244
		CFM	—	—	—	—	—	—	647	518
	MED	m3/h	—	—	—	—	1,000	810	—	—
		l/s	—	—	—	—	278	225	—	—
		CFM	—	—	—	—	589	477	—	—
	LOW	m3/h	—	—	840	680	—	—	—	—
		l/s	—	—	233	189	—	—	—	—
		CFM	—	—	494	400	—	—	—	—
	QUIET	m3/h	660	525	—	—	—	—	—	—
		l/s	183	146	—	—	—	—	—	—
		CFM	388	309	—	—	—	—	—	—

Q-h Characteristic curve

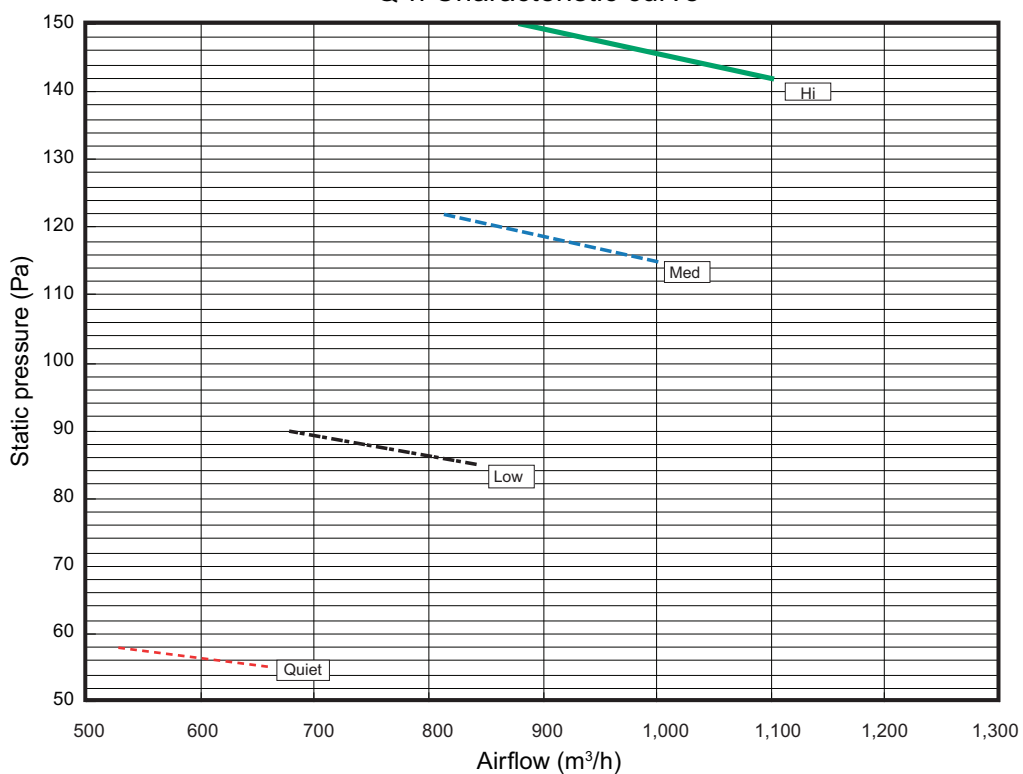

• Cooling

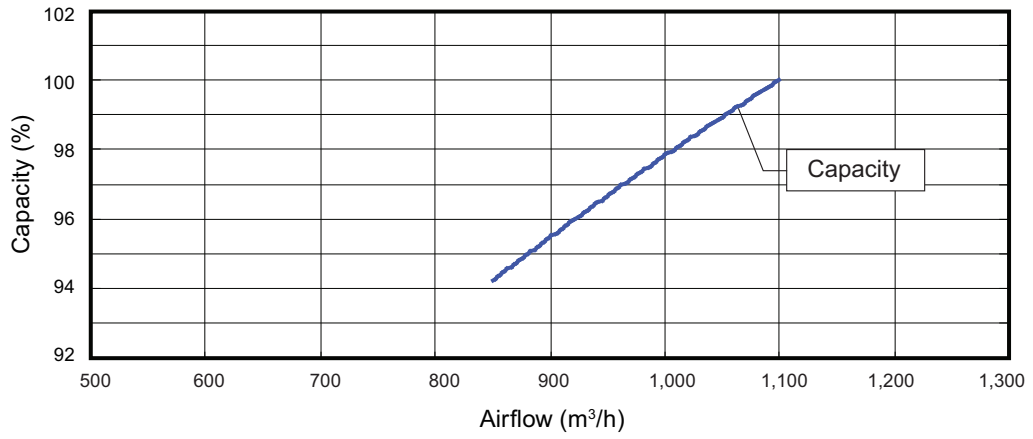

• Heating

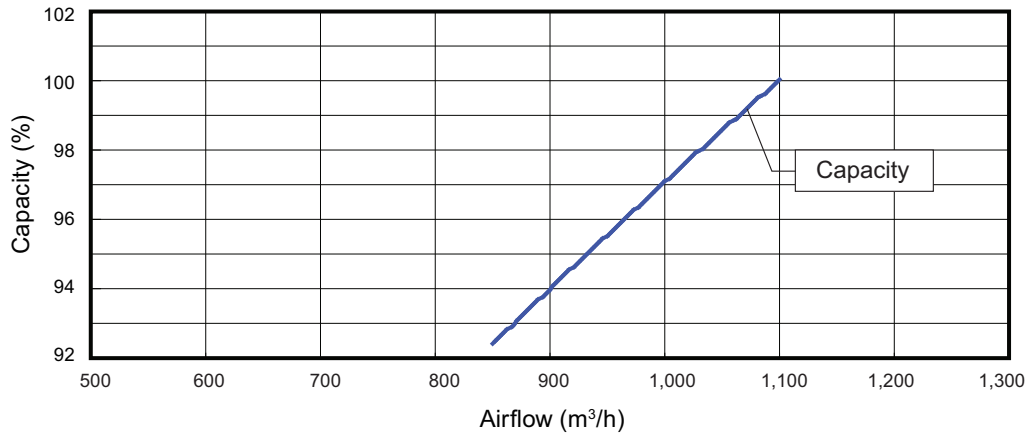

Model: ARHG30LMLE (Normal mode)

			Static pressure (Pa)							
			7	10	13	19	21	30	34	47
Fan speed	HIGH (Heating)	m3/h	—	—	—	—	—	2,270	2,240	2,100
		l/s	—	—	—	—	—	631	622	583
		CFM	—	—	—	—	—	1,336	1,318	1,236
	HIGH (Cooling)	m3/h	—	—	—	—	—	2,050	2,020	1,900
		l/s	—	—	—	—	—	569	561	527
		CFM	—	—	—	—	—	1,207	1,189	1,118
	MED	m3/h	—	—	—	—	1,685	1,585	1,540	—
		l/s	—	—	—	—	468	440	428	—
		CFM	—	—	—	—	992	933	906	—
	LOW	m3/h	—	—	1,325	1,250	1,220	—	—	—
		l/s	—	—	368	347	339	—	—	—
		CFM	—	—	780	736	718	—	—	—
	QUIET	m3/h	1,020	995	960	—	—	—	—	—
		l/s	283	276	267	—	—	—	—	—
		CFM	600	586	565	—	—	—	—	—

Q-h Characteristic curve

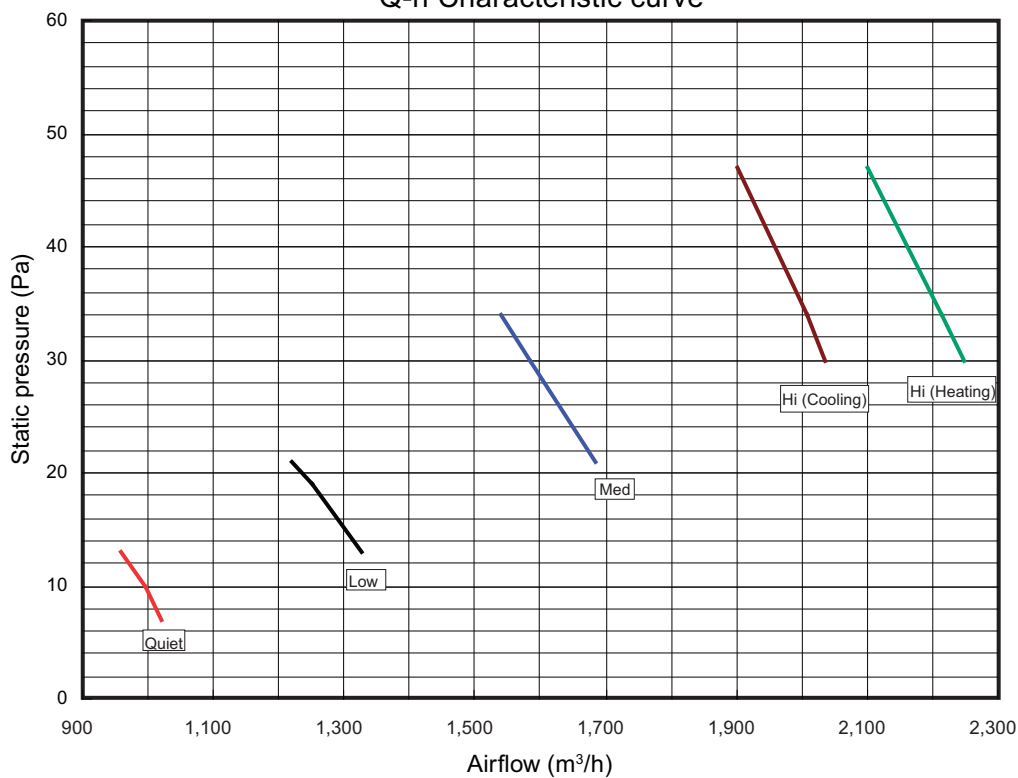

• Cooling

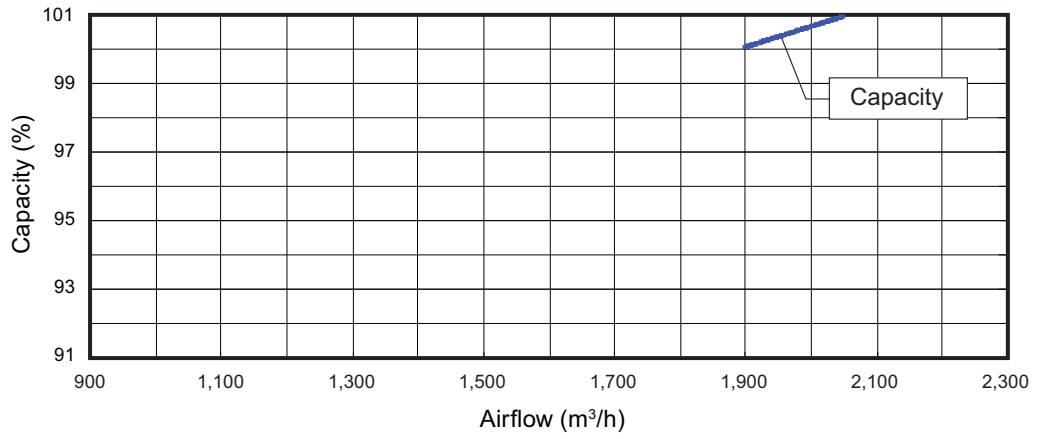

• Heating

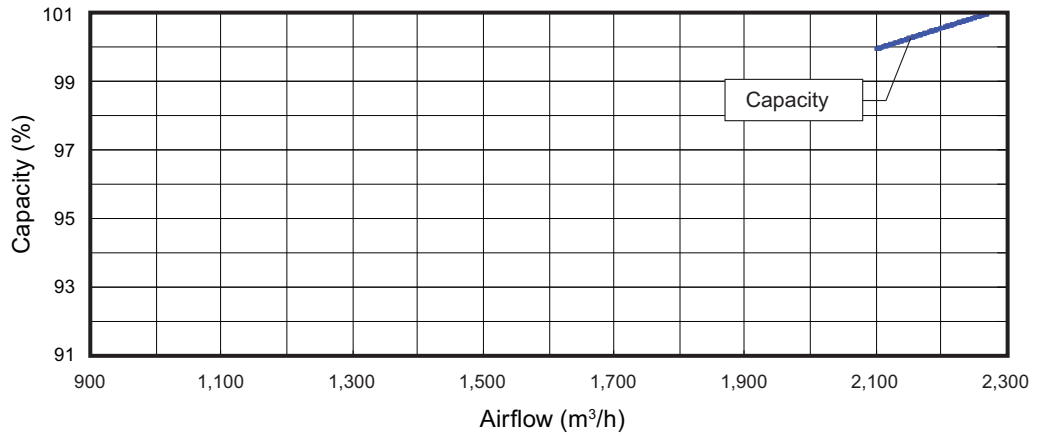

Model: ARHG30LMLE (Static pressure mode 1)

			Static pressure (Pa)							
			17	26	32	38	45	55	64	80
Fan speed	HIGH	m3/h	—	—	—	—	—	1,950	1,860	1,700
		l/s	—	—	—	—	—	542	517	472
		CFM	—	—	—	—	—	1,148	1,095	1,001
	MED	m3/h	—	—	—	—	1,730	1,620	1,520	—
		l/s	—	—	—	—	481	450	422	—
		CFM	—	—	—	—	1,018	953	895	—
	LOW	m3/h	—	1,340	1,265	1,190	—	—	—	—
		l/s	—	372	351	331	—	—	—	—
		CFM	—	789	745	700	—	—	—	—
	QUIET	m3/h	1,080	970	—	—	—	—	—	—
		l/s	300	269	—	—	—	—	—	—
		CFM	636	571	—	—	—	—	—	—

Q-h Characteristic curve

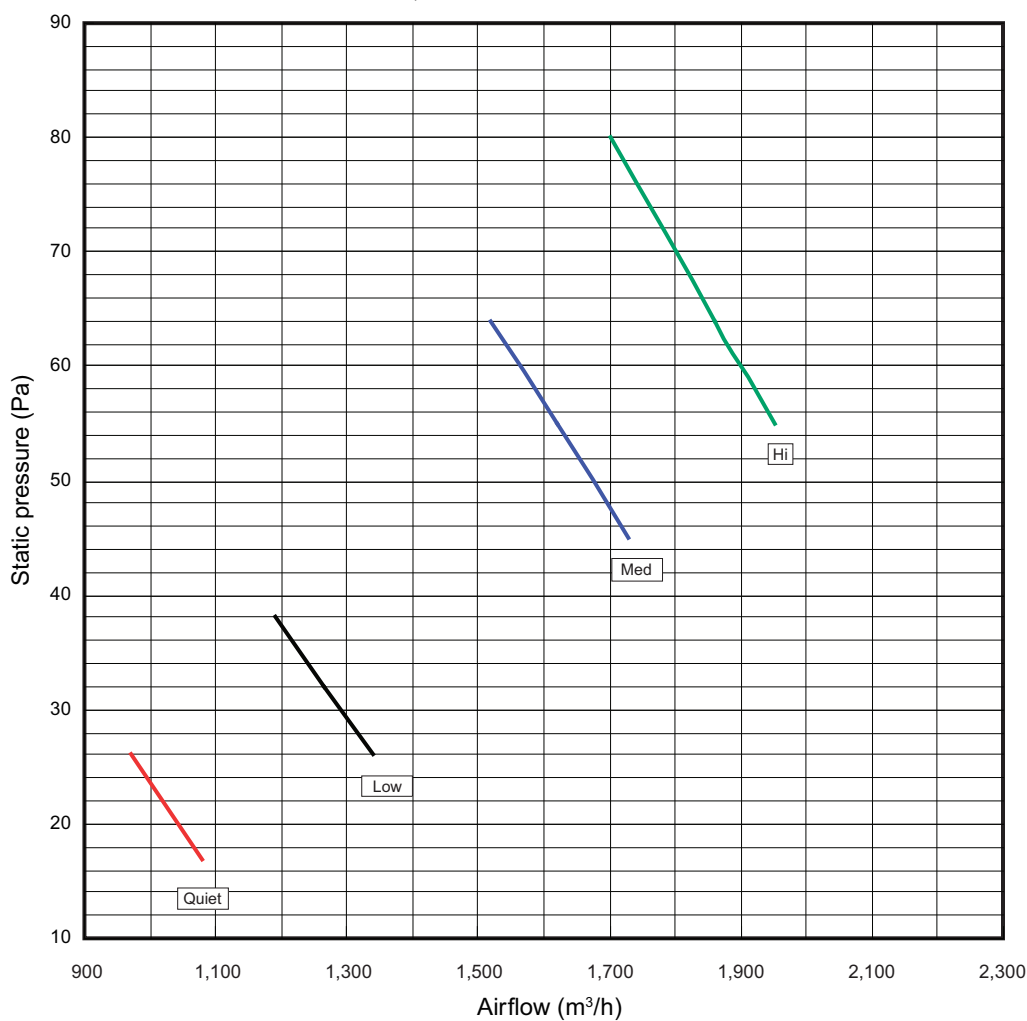

• Cooling

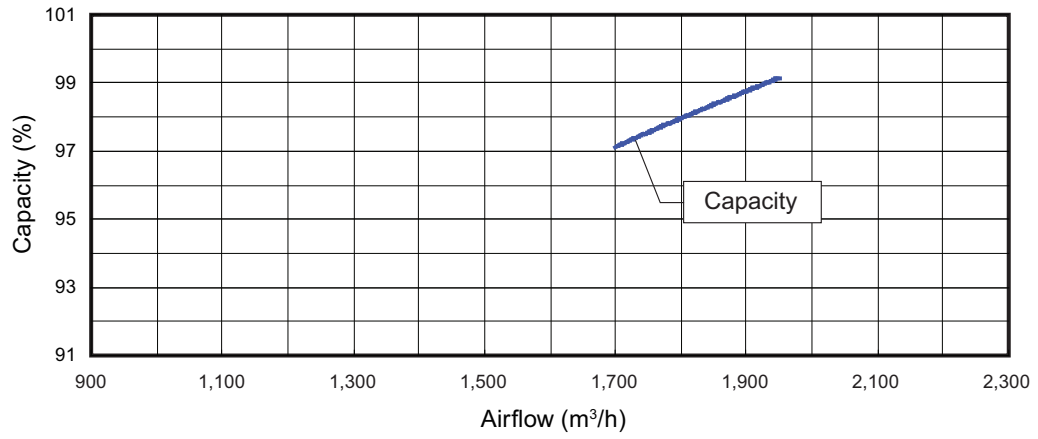

• Heating

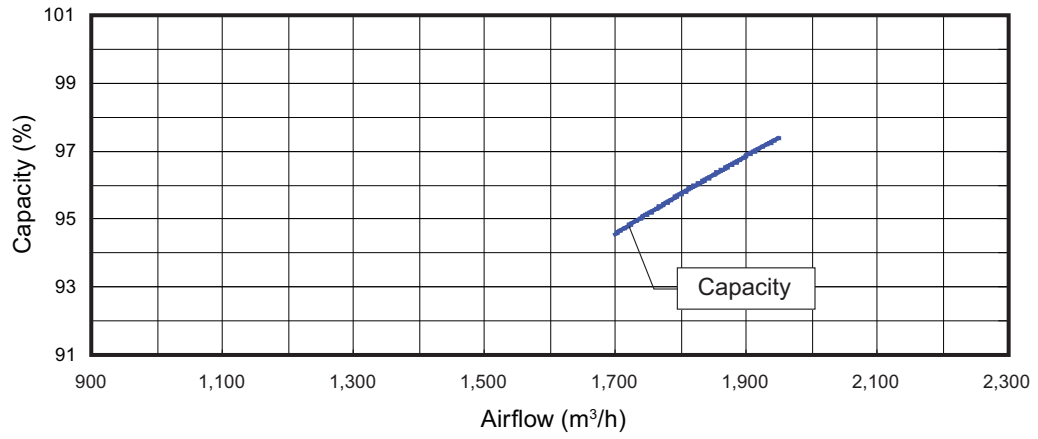

Model: ARHG30LMLE (Static pressure mode 2)

			Static pressure (Pa)							
			33	40	49	60	70	85	93	112
Fan speed	HIGH	m3/h	—	—	—	—	—	—	1,850	1,600
		l/s	—	—	—	—	—	—	514	444
		CFM	—	—	—	—	—	—	1,089	942
	MED	m3/h	—	—	—	—	1,600	1,400	—	—
		l/s	—	—	—	—	444	389	—	—
		CFM	—	—	—	—	942	824	—	—
	LOW	m3/h	—	—	1,340	1,180	—	—	—	—
		l/s	—	—	372	328	—	—	—	—
		CFM	—	—	789	695	—	—	—	—
	QUIET	m3/h	1,090	960	—	—	—	—	—	—
		l/s	303	267	—	—	—	—	—	—
		CFM	642	565	—	—	—	—	—	—

Q-h Characteristic curve

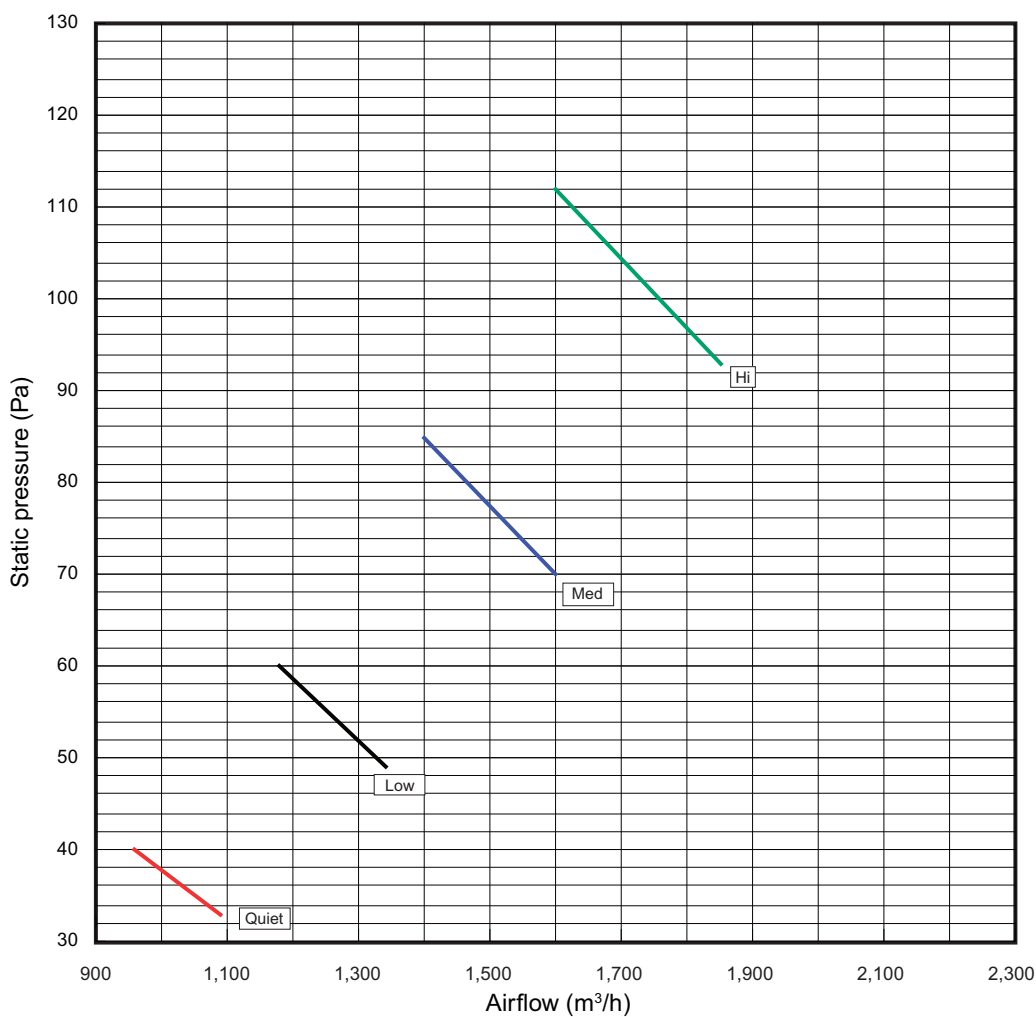

• Cooling

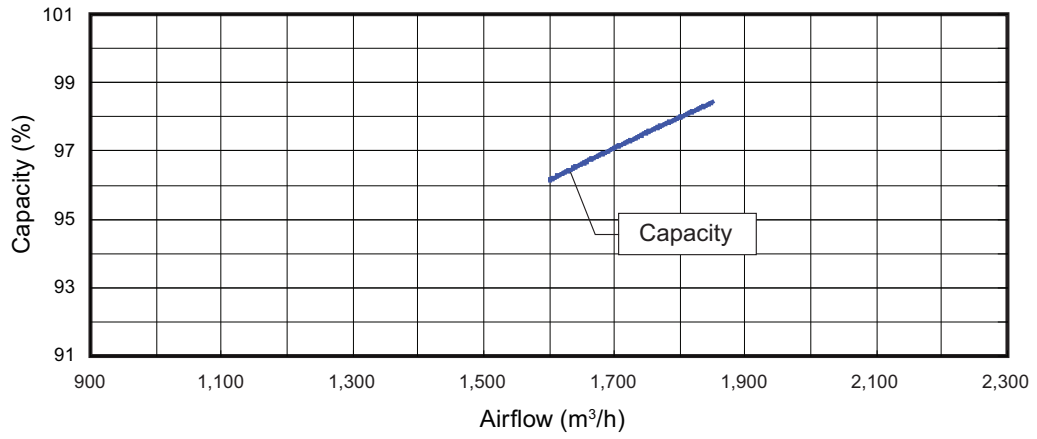

• Heating

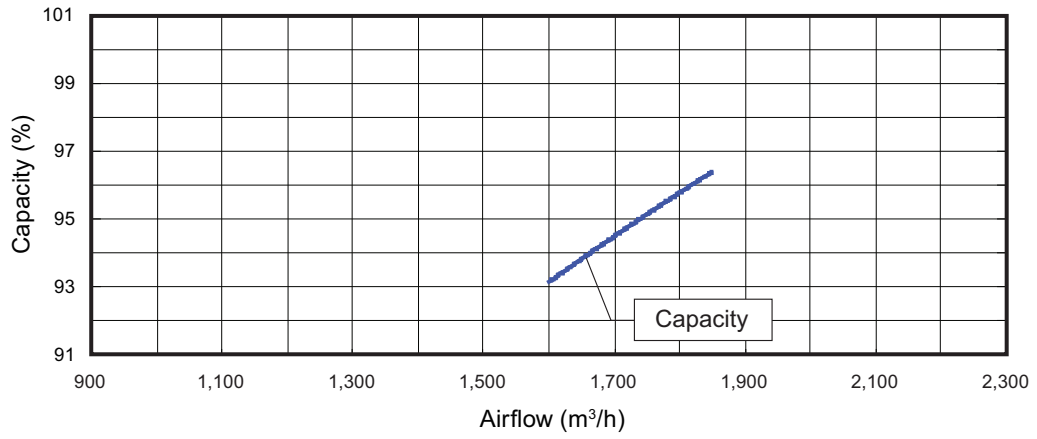

Model: ARHG30LMLE (Static pressure mode 3)

			Static pressure (Pa)							
			55	63	77	89	102	117	130	150
Fan speed	HIGH	m3/h	—	—	—	—	—	—	1,730	1,500
		l/s	—	—	—	—	—	—	481	417
		CFM	—	—	—	—	—	—	1,018	883
	MED	m3/h	—	—	—	—	1,530	1,310	—	—
		l/s	—	—	—	—	425	364	—	—
		CFM	—	—	—	—	901	771	—	—
	LOW	m3/h	—	—	1,330	1,140	—	—	—	—
		l/s	—	—	369	317	—	—	—	—
		CFM	—	—	783	671	—	—	—	—
	QUIET	m3/h	1,110	960	—	—	—	—	—	—
		l/s	308	267	—	—	—	—	—	—
		CFM	653	565	—	—	—	—	—	—

Q-h Characteristic curve

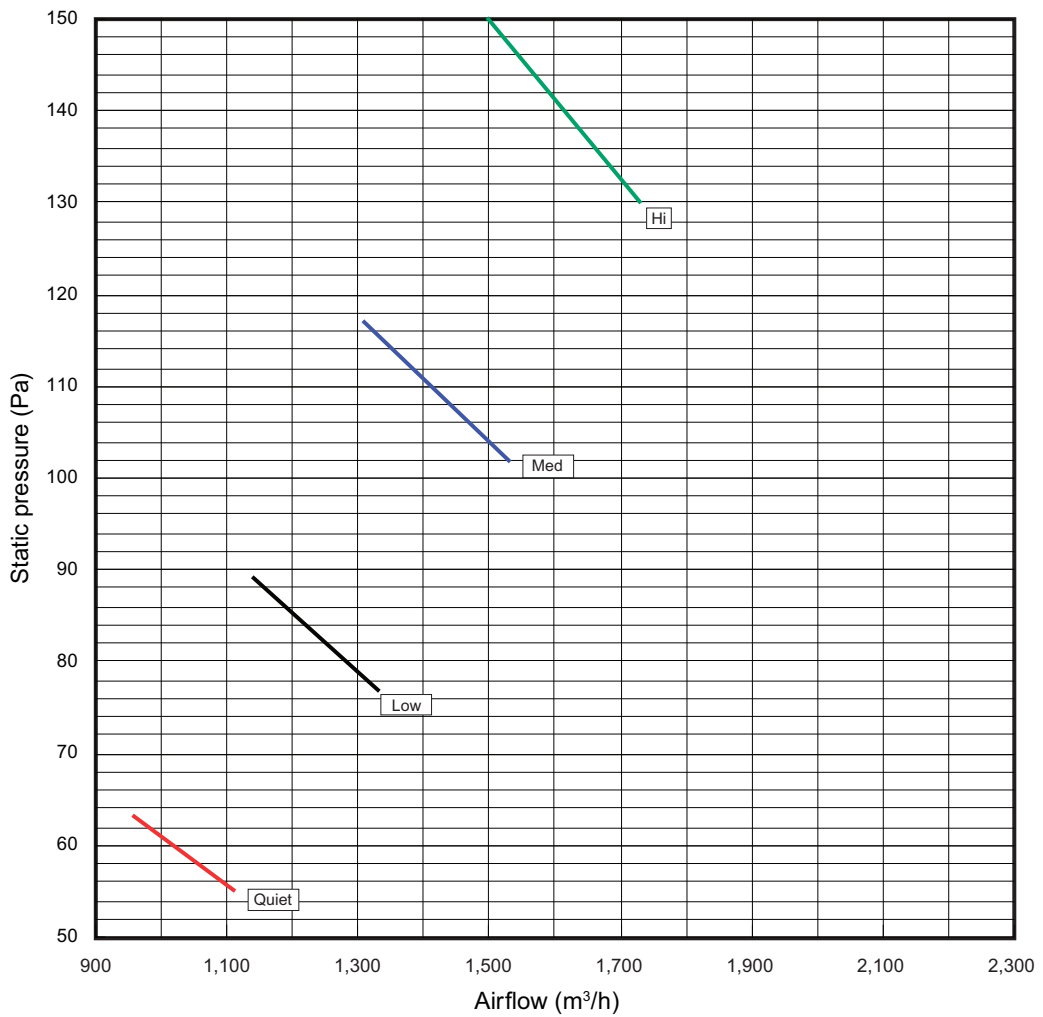

• Cooling

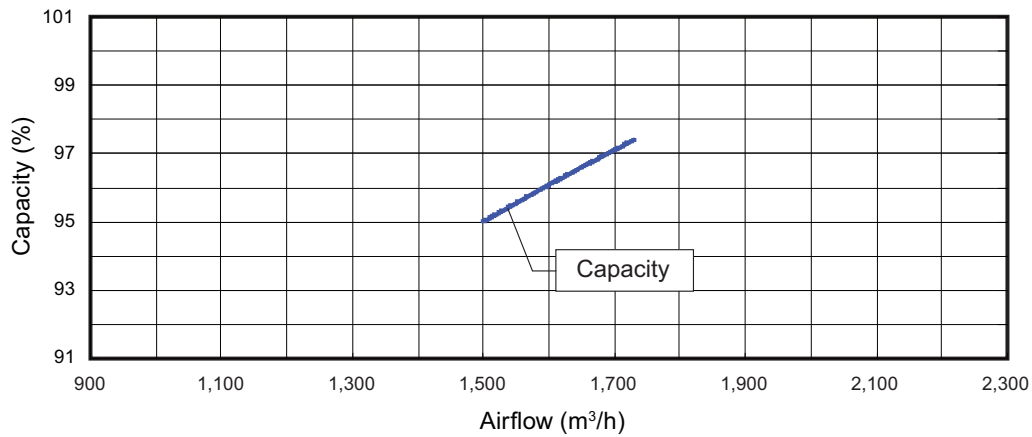

• Heating

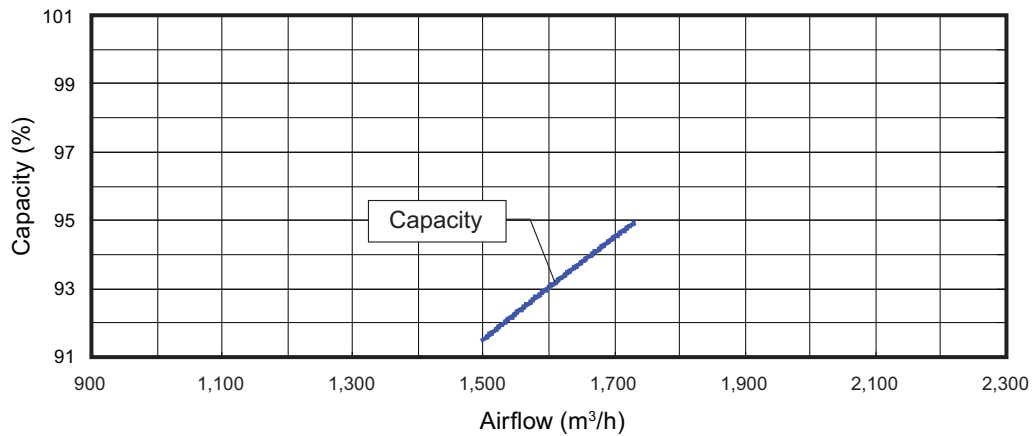

■ Model: ARHG36LMLE (Normal mode)

			Static pressure (Pa)							
			7	10	13	19	21	30	34	47
Fan speed	HIGH (Heating)	m3/h	—	—	—	—	—	2,270	2,240	2,100
		l/s	—	—	—	—	—	631	622	583
		CFM	—	—	—	—	—	1,336	1,318	1,236
	HIGH (Cooling)	m3/h	—	—	—	—	—	2,050	2,020	1,900
		l/s	—	—	—	—	—	569	561	527
		CFM	—	—	—	—	—	1,207	1,189	1,118
	MED	m3/h	—	—	—	—	1,685	1,585	1,540	—
		l/s	—	—	—	—	468	440	428	—
		CFM	—	—	—	—	992	933	906	—
	LOW	m3/h	—	—	1,325	1,250	1,220	—	—	—
		l/s	—	—	368	347	339	—	—	—
		CFM	—	—	780	736	718	—	—	—
	QUIET	m3/h	1,020	995	960	—	—	—	—	—
		l/s	283	276	267	—	—	—	—	—
		CFM	600	586	565	—	—	—	—	—

Q-h Characteristic curve

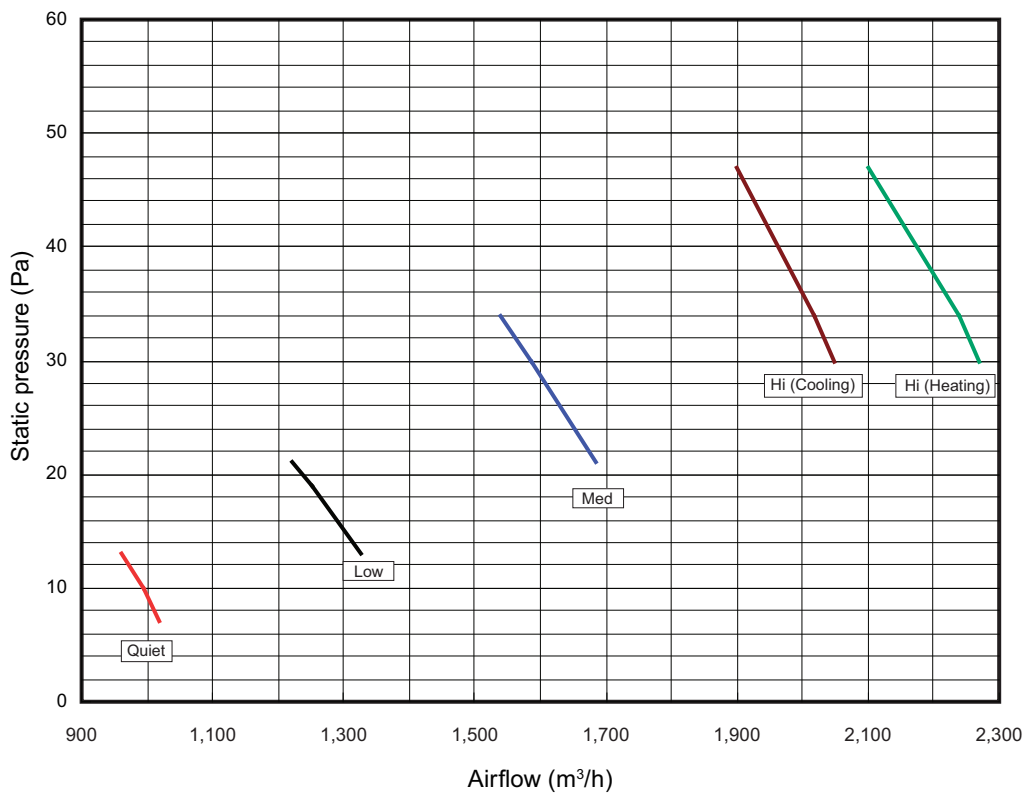

• Cooling

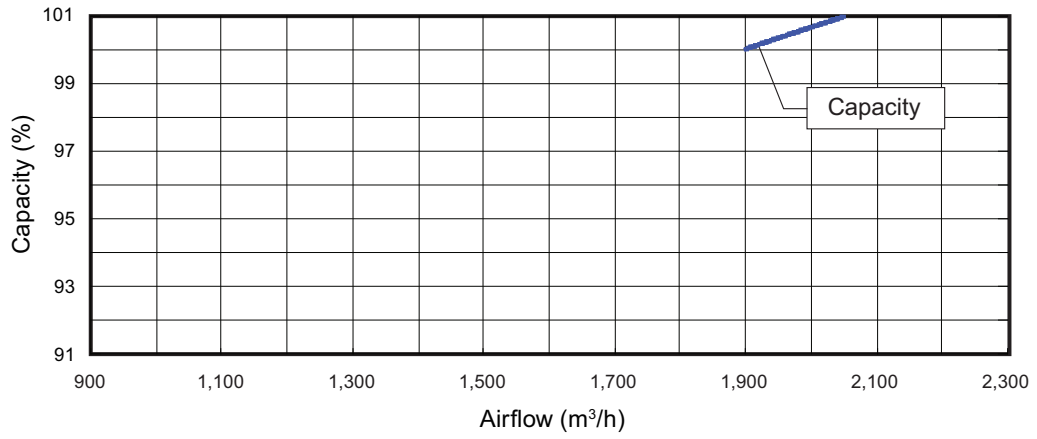

• Heating

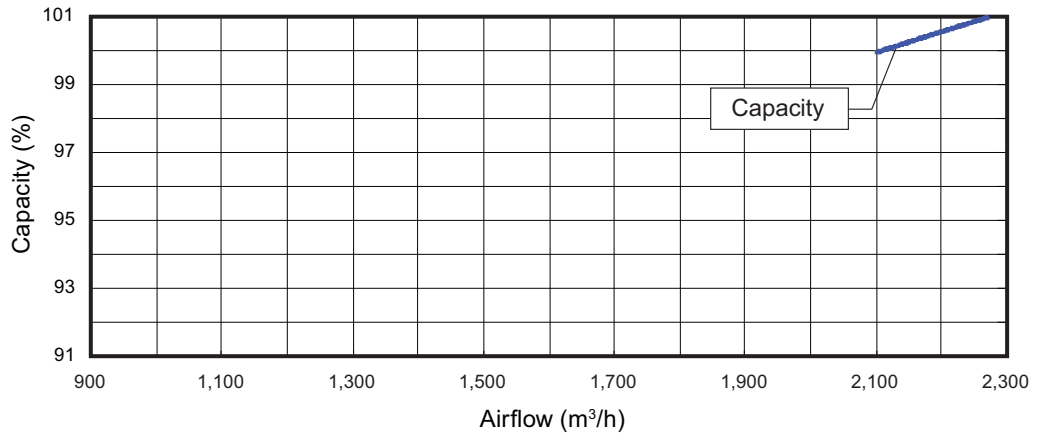

■ Model: ARHG36LMLE (Static pressure mode 1)

			Static pressure (Pa)							
			17	26	32	38	45	55	64	80
Fan speed	HIGH	m3/h	—	—	—	—	—	1,950	1,860	1,700
		l/s	—	—	—	—	—	542	517	472
		CFM	—	—	—	—	—	1,148	1,095	1,001
	MED	m3/h	—	—	—	—	1,730	1,620	1,520	—
		l/s	—	—	—	—	481	450	422	—
		CFM	—	—	—	—	1,018	953	895	—
	LOW	m3/h	—	1,340	1,265	1,190	—	—	—	—
		l/s	—	372	351	331	—	—	—	—
		CFM	—	789	745	700	—	—	—	—
	QUIET	m3/h	1,080	970	—	—	—	—	—	—
		l/s	300	269	—	—	—	—	—	—
		CFM	636	571	—	—	—	—	—	—

Q-h Characteristic curve

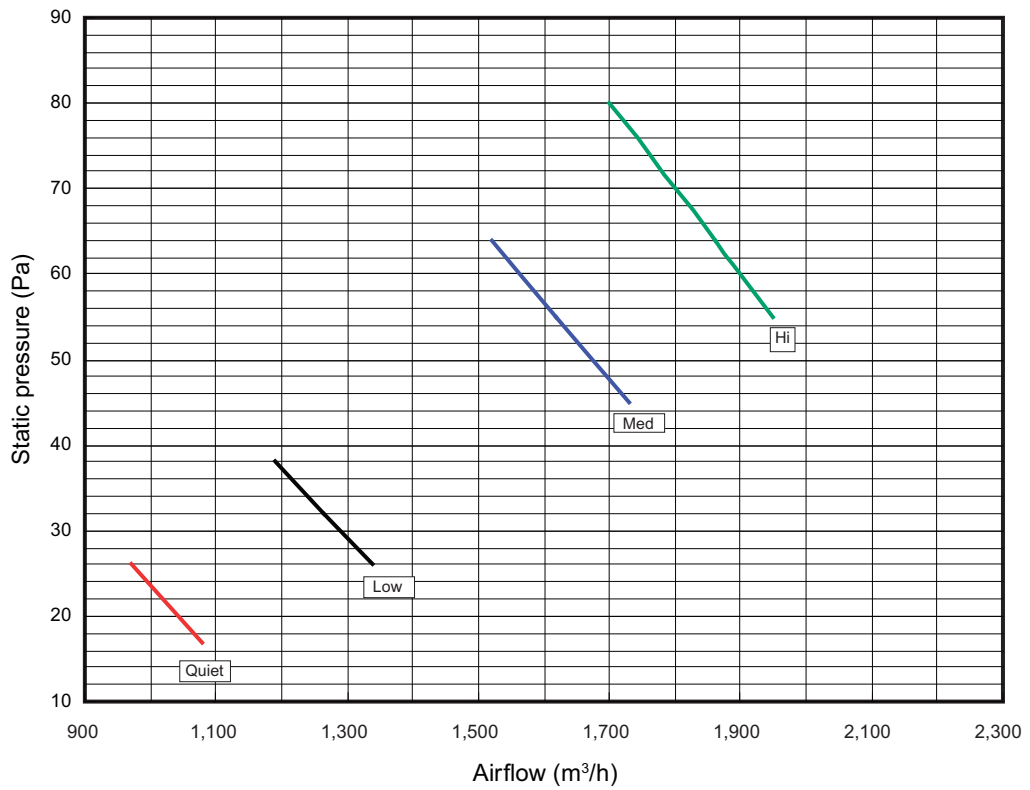

• Cooling

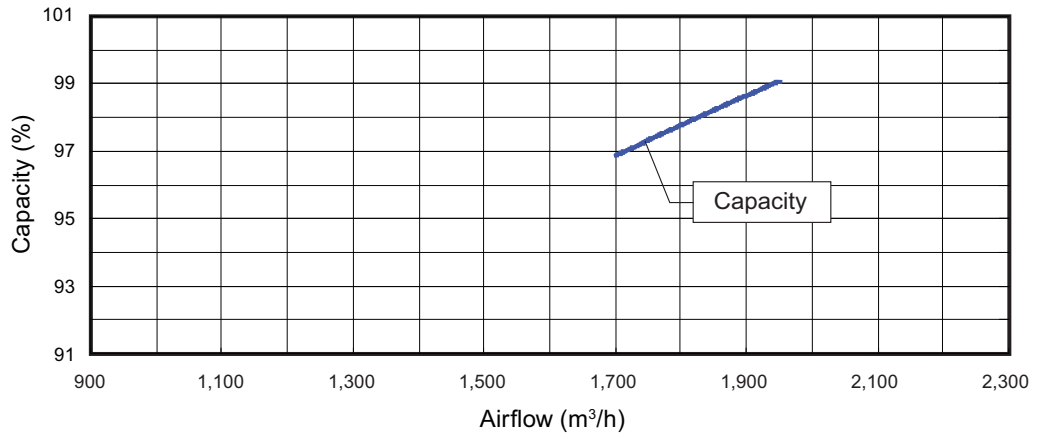

• Heating

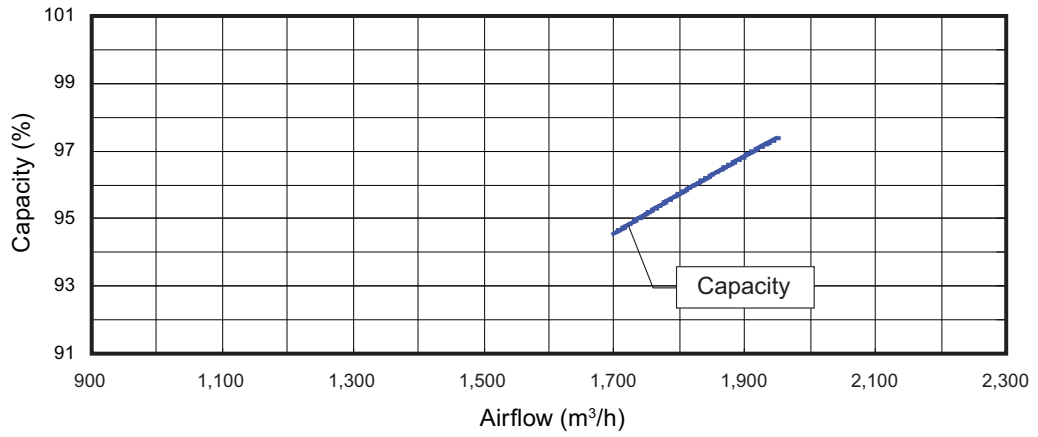

Model: ARHG36LMLE (Static pressure mode 2)

			Static pressure (Pa)							
			33	40	49	60	70	85	93	112
Fan speed	HIGH	m3/h	—	—	—	—	—	—	1,850	1,600
		l/s	—	—	—	—	—	—	514	444
		CFM	—	—	—	—	—	—	1,089	942
	MED	m3/h	—	—	—	—	1,600	1,400	—	—
		l/s	—	—	—	—	444	389	—	—
		CFM	—	—	—	—	942	824	—	—
	LOW	m3/h	—	—	1,340	1,180	—	—	—	—
		l/s	—	—	372	328	—	—	—	—
		CFM	—	—	789	695	—	—	—	—
	QUIET	m3/h	1,090	960	—	—	—	—	—	—
		l/s	303	267	—	—	—	—	—	—
		CFM	642	565	—	—	—	—	—	—

Q-h Characteristic curve

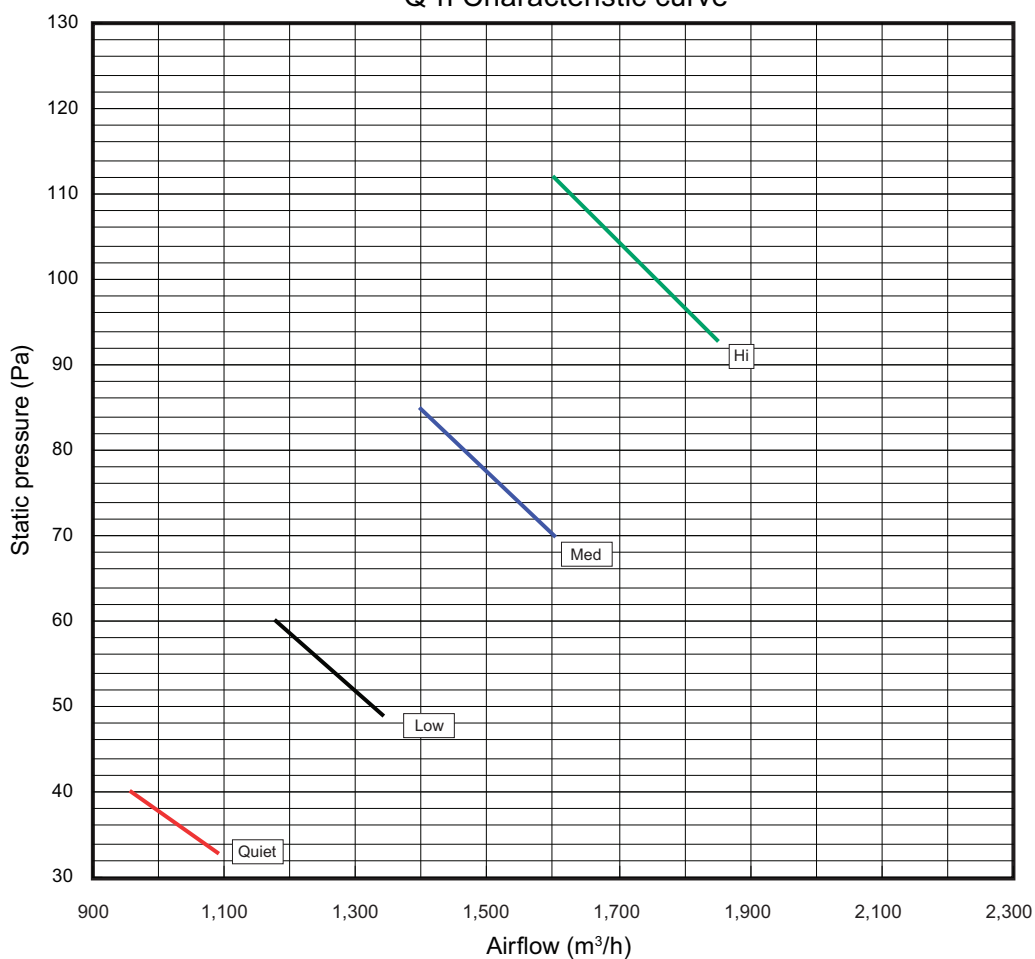

• Cooling

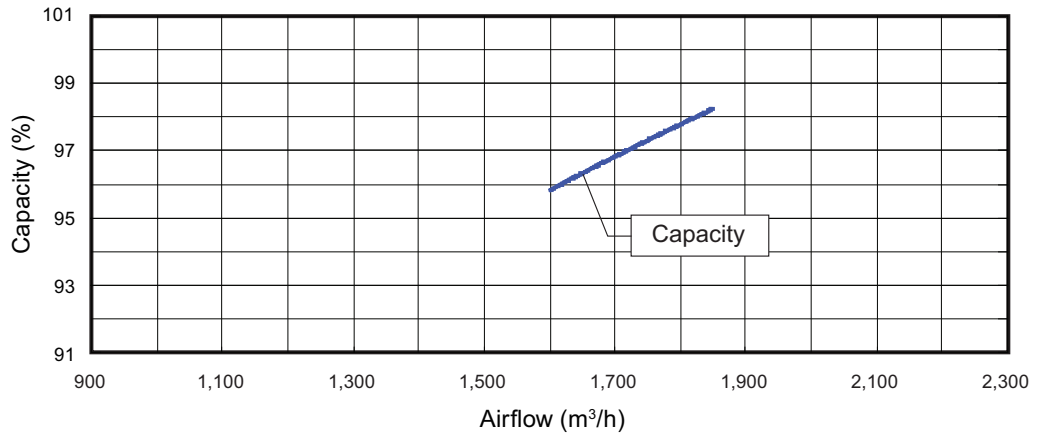

• Heating

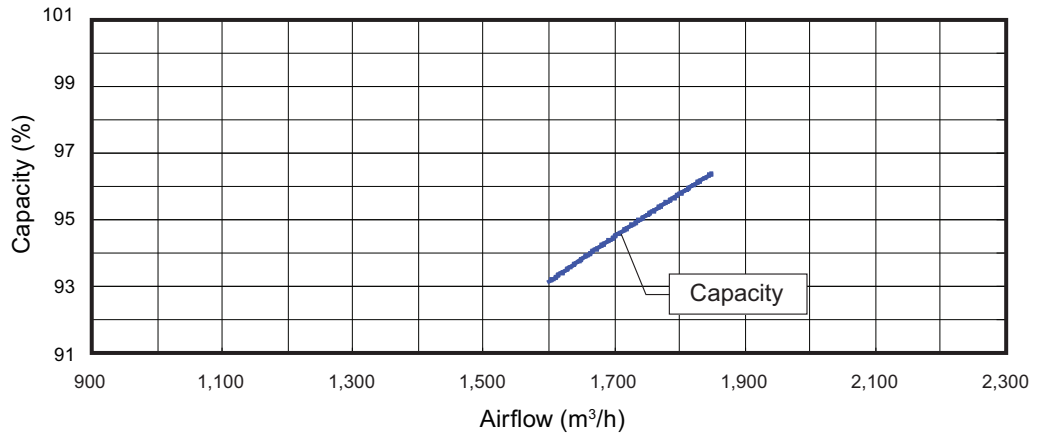

Model: ARHG36LMLE (Static pressure mode 3)

			Static pressure (Pa)							
			55	63	77	89	102	117	130	150
Fan speed	HIGH	m3/h	—	—	—	—	—	—	1,730	1,500
		l/s	—	—	—	—	—	—	481	417
		CFM	—	—	—	—	—	—	1,018	883
	MED	m3/h	—	—	—	—	1,530	1,310	—	—
		l/s	—	—	—	—	425	364	—	—
		CFM	—	—	—	—	901	771	—	—
	LOW	m3/h	—	—	1,330	1,140	—	—	—	—
		l/s	—	—	369	317	—	—	—	—
		CFM	—	—	783	671	—	—	—	—
	QUIET	m3/h	1,110	960	—	—	—	—	—	—
		l/s	308	267	—	—	—	—	—	—
		CFM	653	565	—	—	—	—	—	—

Q-h Characteristic curve

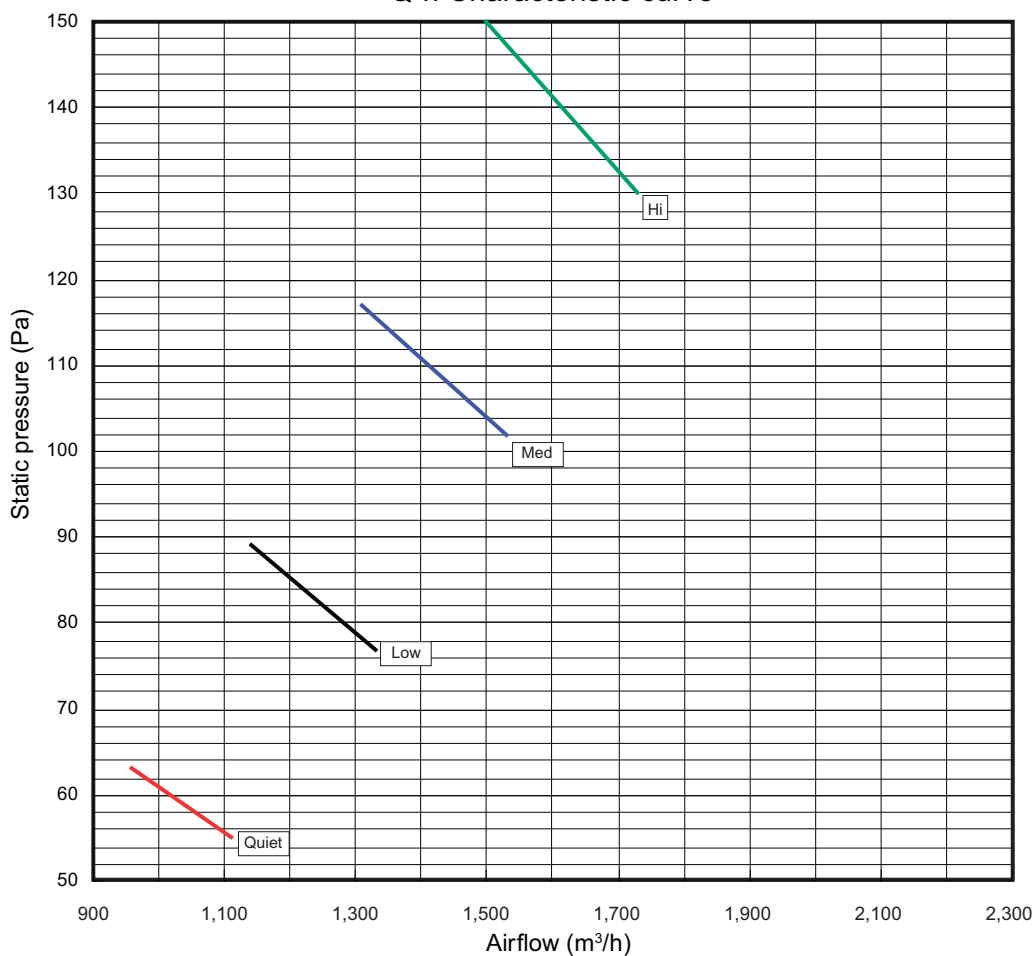

• Cooling

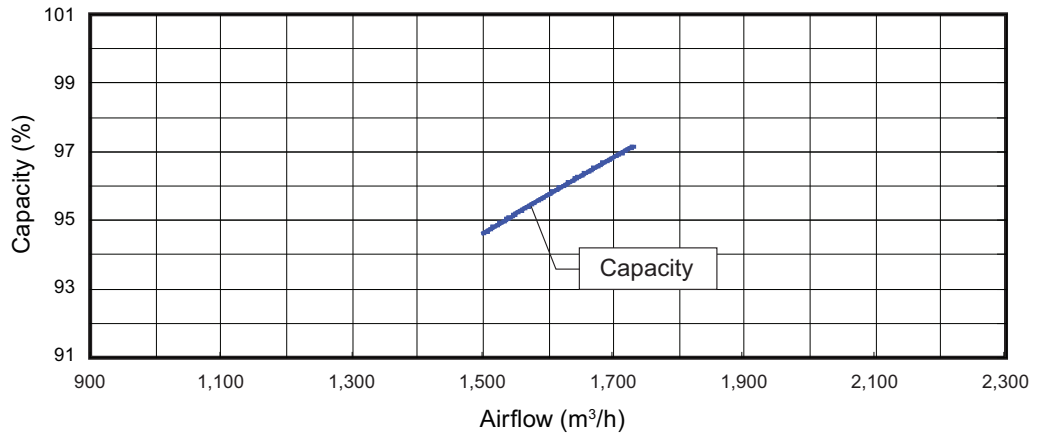

• Heating

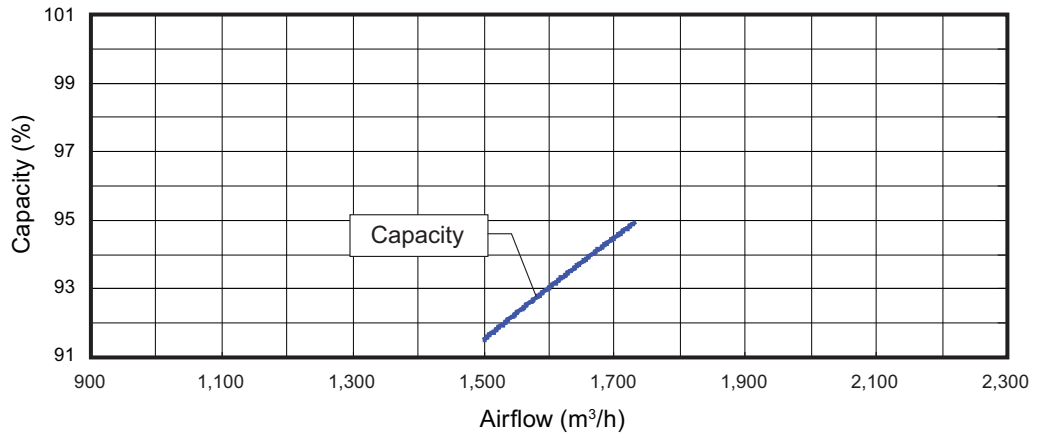

Model: ARHG45LMLA (Normal mode)

			Static pressure (Pa)							
			7	10	13	19	21	30	34	57
Fan speed	HIGH	m3/h	—	—	—	—	—	2,250	2,223	2,010
		l/s	—	—	—	—	—	625	618	558
		CFM	—	—	—	—	—	1,324	1,308	1,183
	MED	m3/h	—	—	—	1,710	1,685	1,585	1,540	—
		l/s	—	—	—	475	468	440	428	—
		CFM	—	—	—	1,006	992	933	906	—
	LOW	m3/h	—	—	1,325	1,250	1,220	—	—	—
		l/s	—	—	368	347	339	—	—	—
		CFM	—	—	780	736	718	—	—	—
	QUIET	m3/h	1,020	995	960	—	—	—	—	—
		l/s	283	276	267	—	—	—	—	—
		CFM	600	586	565	—	—	—	—	—

Q-h Characteristic curve

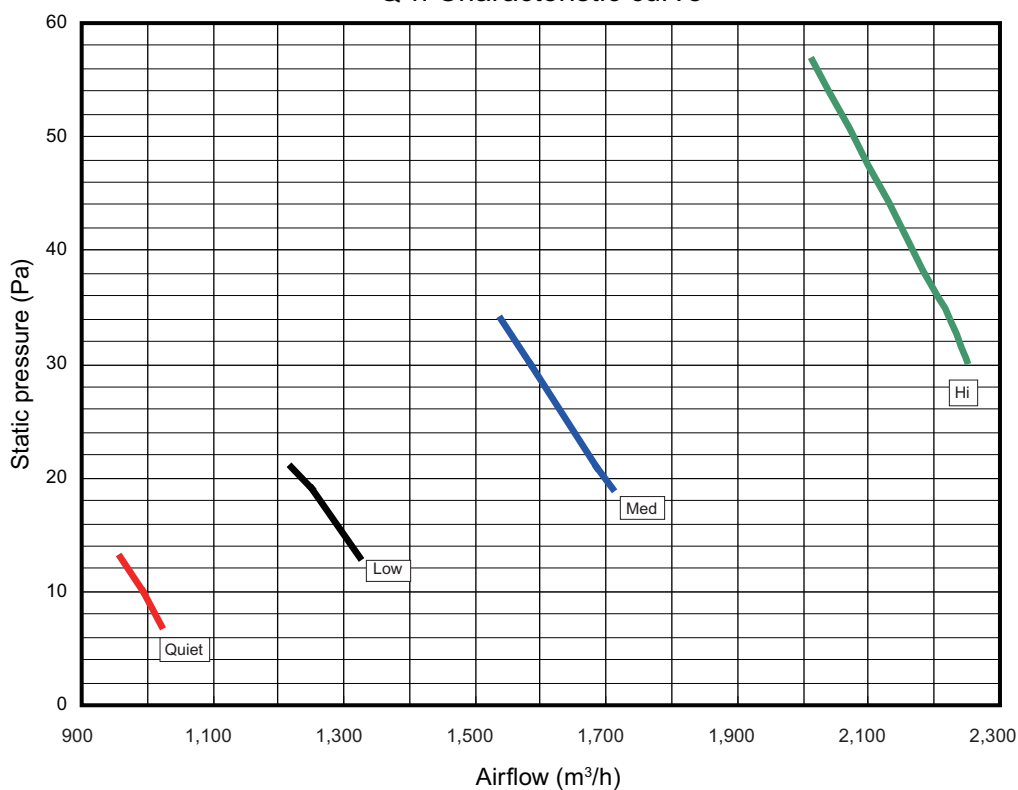

• Cooling

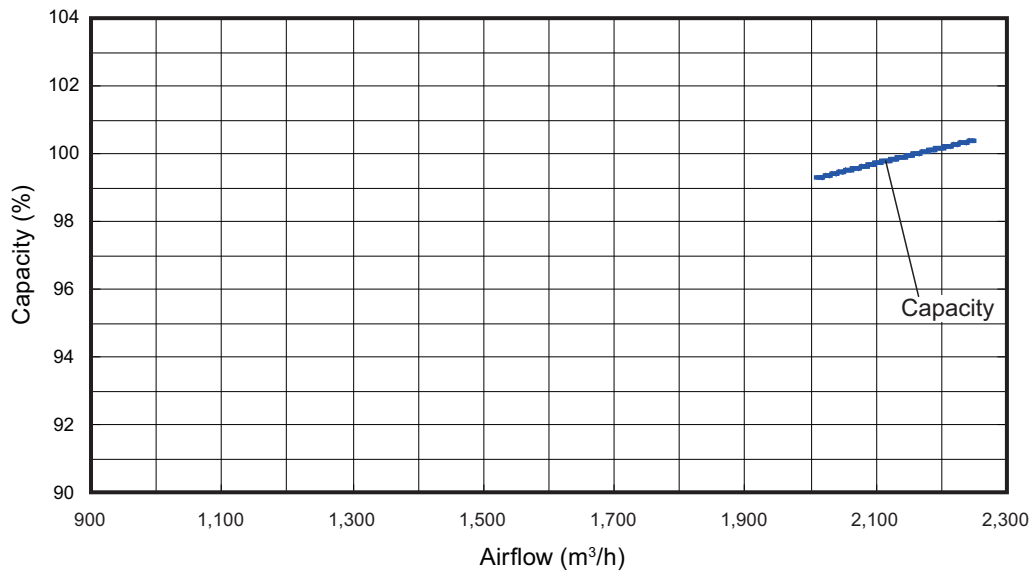

• Heating

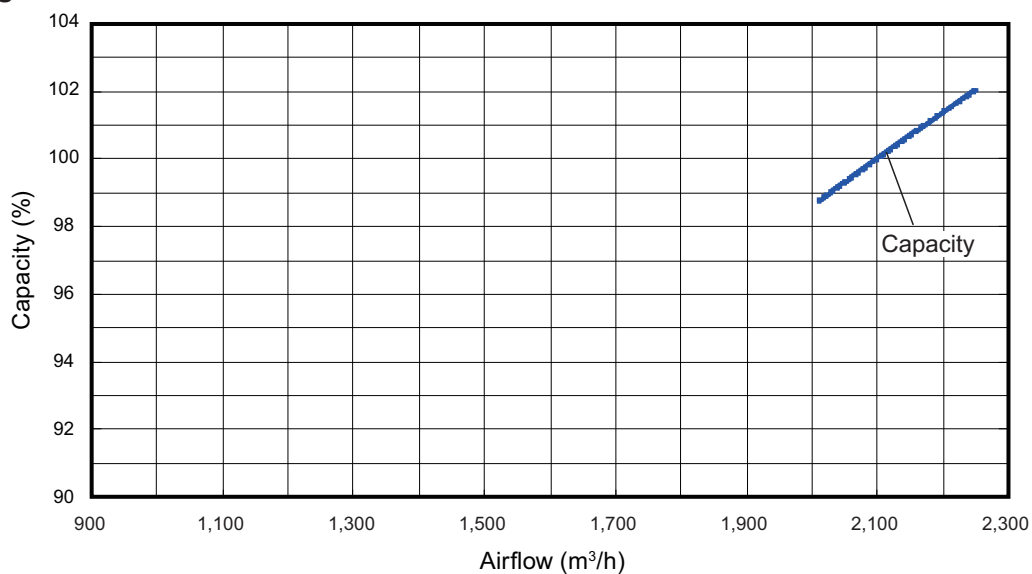

Model: ARHG45LMLA (Static pressure mode 1)

			Static pressure (Pa)							
			17	26	38	43	60	63	75	90
Fan speed	HIGH	m3/h	—	—	—	—	2,100	2,075	1,970	1,810
		l/s	—	—	—	—	583	576	547	503
		CFM	—	—	—	—	1,236	1,221	1,159	1,065
	MED	m3/h	—	—	—	1,750	1,555	1,520	—	—
		l/s	—	—	—	486	432	422	—	—
		CFM	—	—	—	1,030	915	895	—	—
	LOW	m3/h	—	1,350	1,190	—	—	—	—	—
		l/s	—	375	331	—	—	—	—	—
		CFM	—	795	700	—	—	—	—	—
	QUIET	m3/h	1,070	970	—	—	—	—	—	—
		l/s	297	269	—	—	—	—	—	—
		CFM	630	571	—	—	—	—	—	—

Q-h Characteristic curve

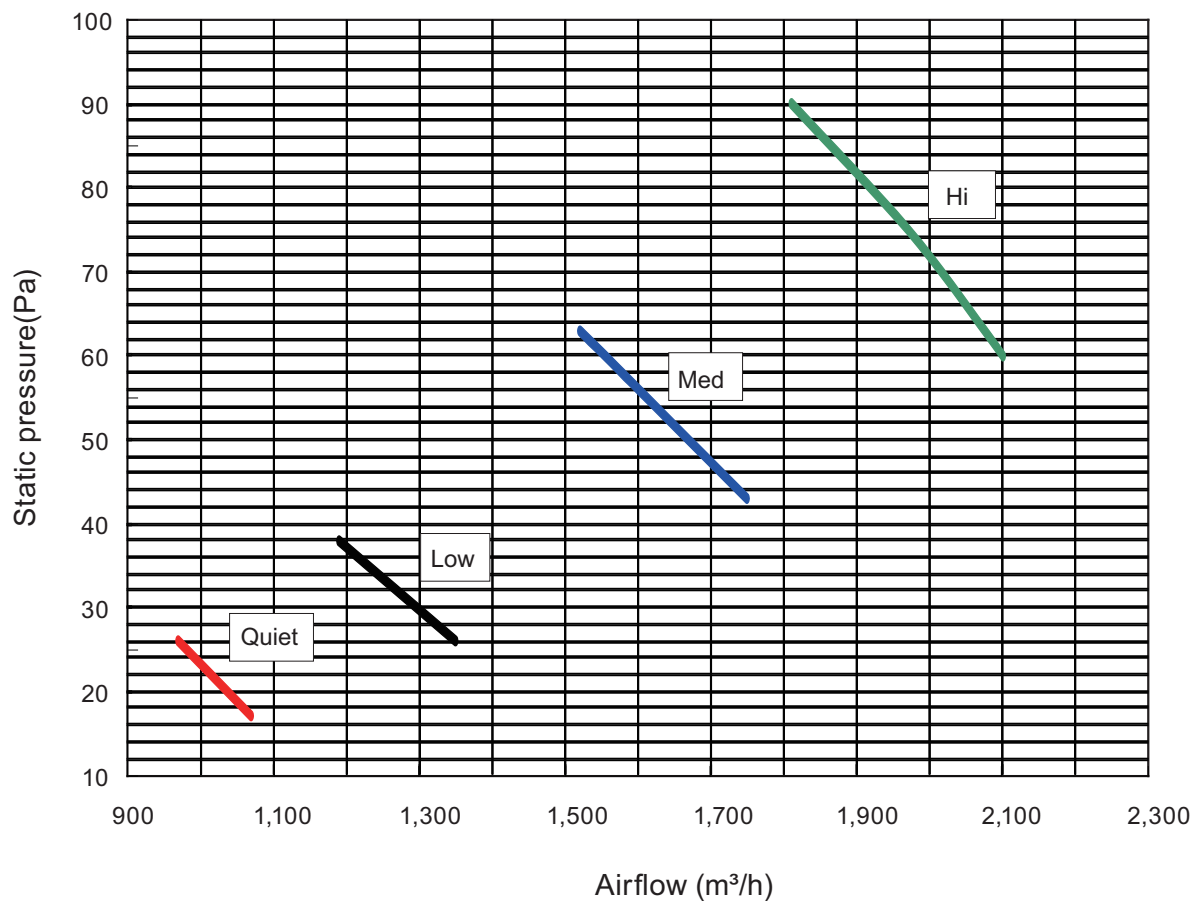

• Cooling

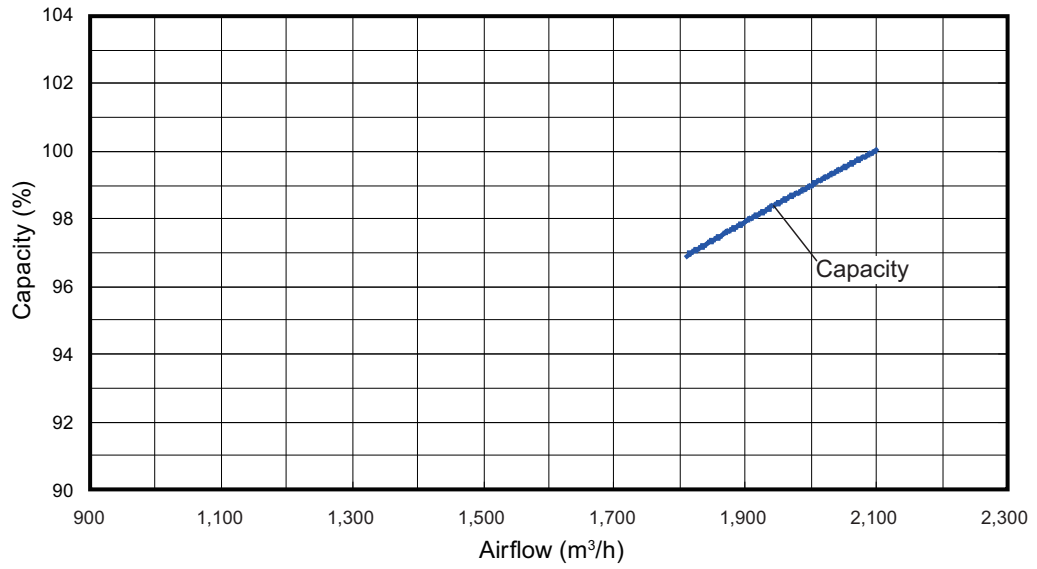

• Heating

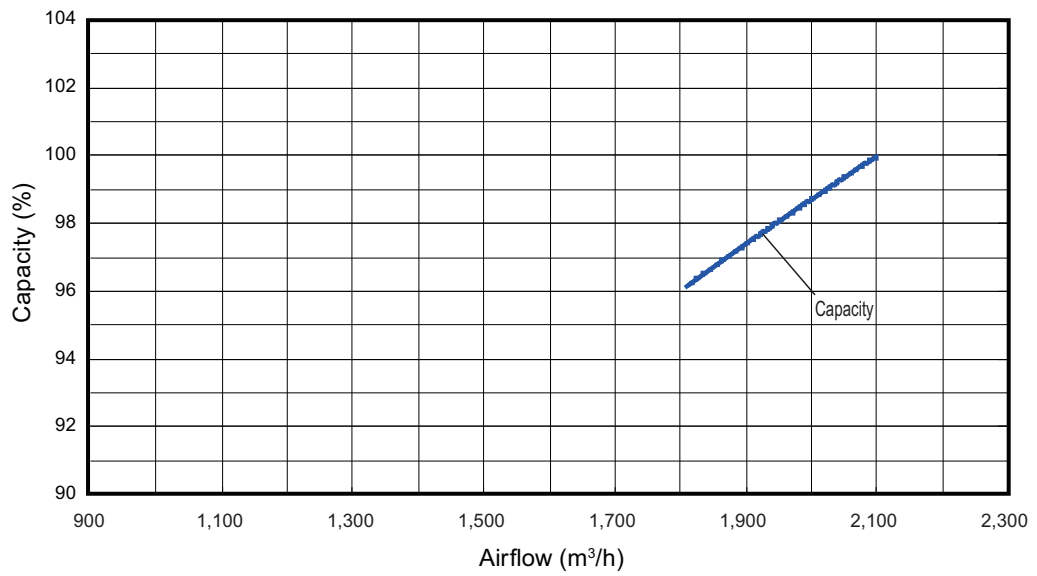

Model: ARHG45LMLA (Static pressure mode 2)

			Static pressure (Pa)							
			33	40	49	60	70	85	100	120
Fan speed	HIGH	m3/h	—	—	—	—	—	—	1,900	1,660
		l/s	—	—	—	—	—	—	528	461
		CFM	—	—	—	—	—	—	1,118	977
	MED	m3/h	—	—	—	—	1,600	1,400	—	—
		l/s	—	—	—	—	444	389	—	—
		CFM	—	—	—	—	942	824	—	—
	LOW	m3/h	—	—	1,340	1,180	—	—	—	—
		l/s	—	—	372	328	—	—	—	—
		CFM	—	—	789	695	—	—	—	—
	QUIET	m3/h	1,090	960	—	—	—	—	—	—
		l/s	303	267	—	—	—	—	—	—
		CFM	642	565	—	—	—	—	—	—

Q-h Characteristic curve

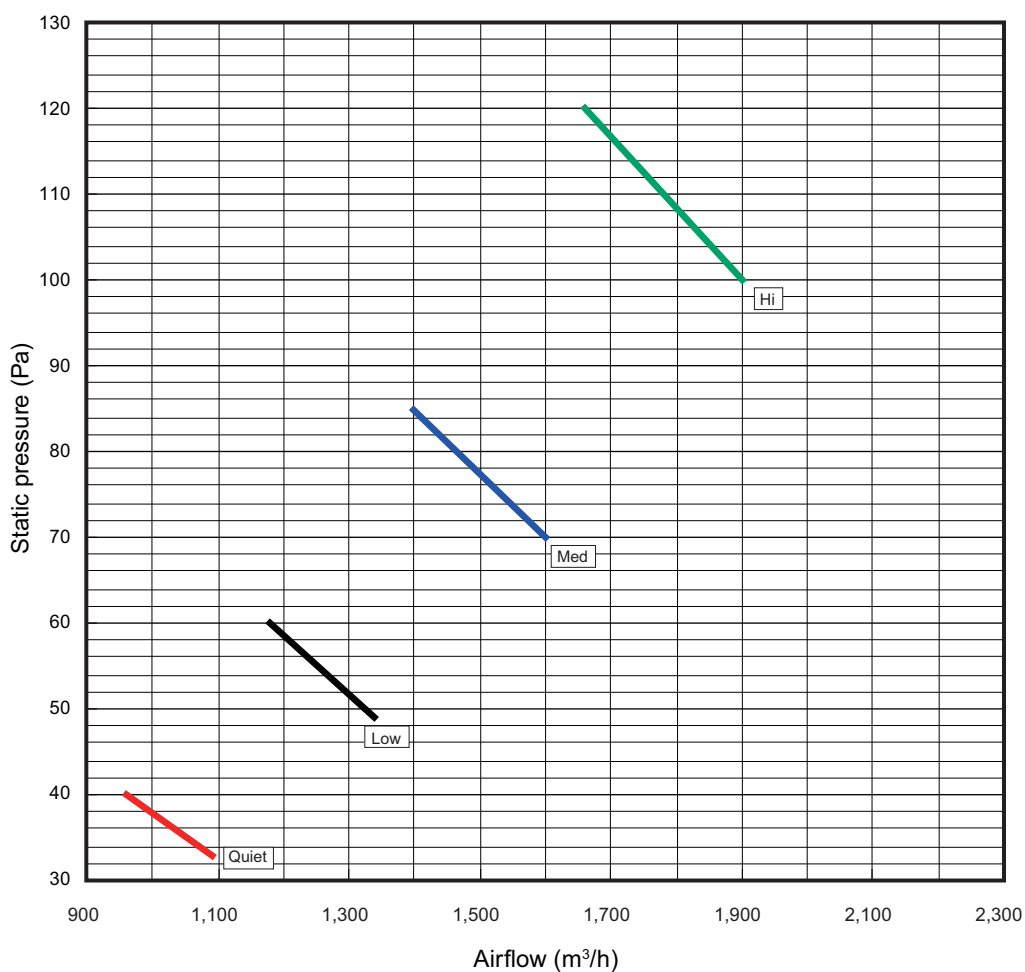

• Cooling

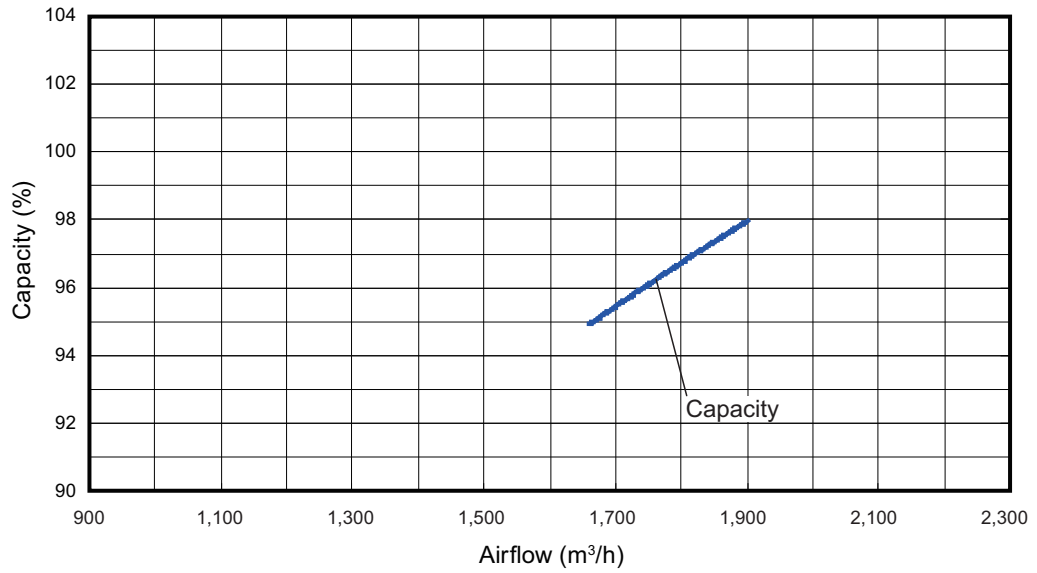

• Heating

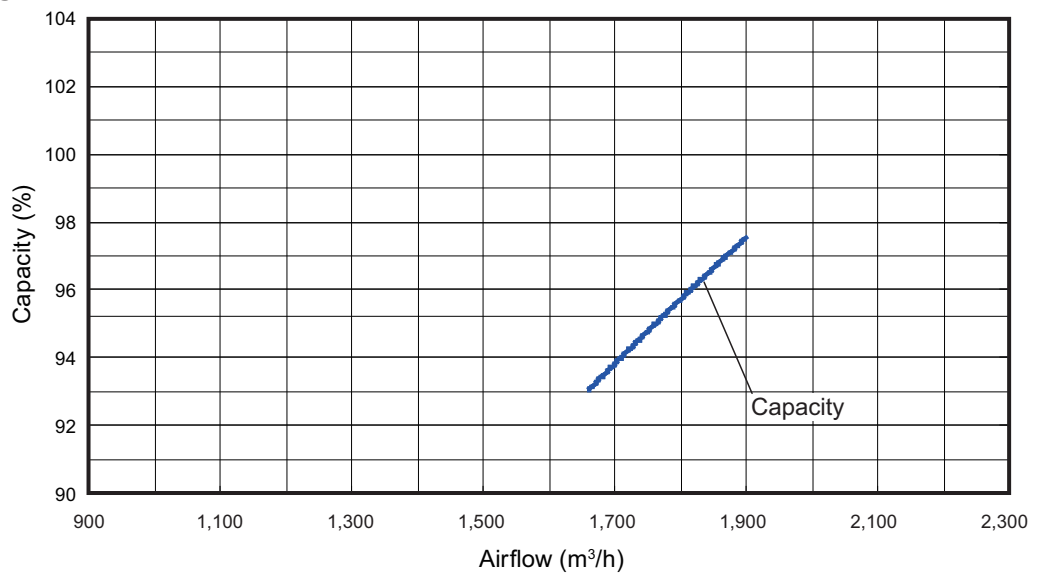

Model: ARHG45LMLA (Static pressure mode 3)

			Static pressure (Pa)							
			55	63	77	89	102	117	130	150
Fan speed	HIGH	m3/h	—	—	—	—	—	—	1,730	1,500
		l/s	—	—	—	—	—	—	481	417
		CFM	—	—	—	—	—	—	1,018	883
	MED	m3/h	—	—	—	—	1,530	1,310	—	—
		l/s	—	—	—	—	425	364	—	—
		CFM	—	—	—	—	901	771	—	—
	LOW	m3/h	—	—	1,330	1,140	—	—	—	—
		l/s	—	—	369	317	—	—	—	—
		CFM	—	—	783	671	—	—	—	—
	QUIET	m3/h	1,110	960	—	—	—	—	—	—
		l/s	308	267	—	—	—	—	—	—
		CFM	653	565	—	—	—	—	—	—

Q-h Characteristic curve

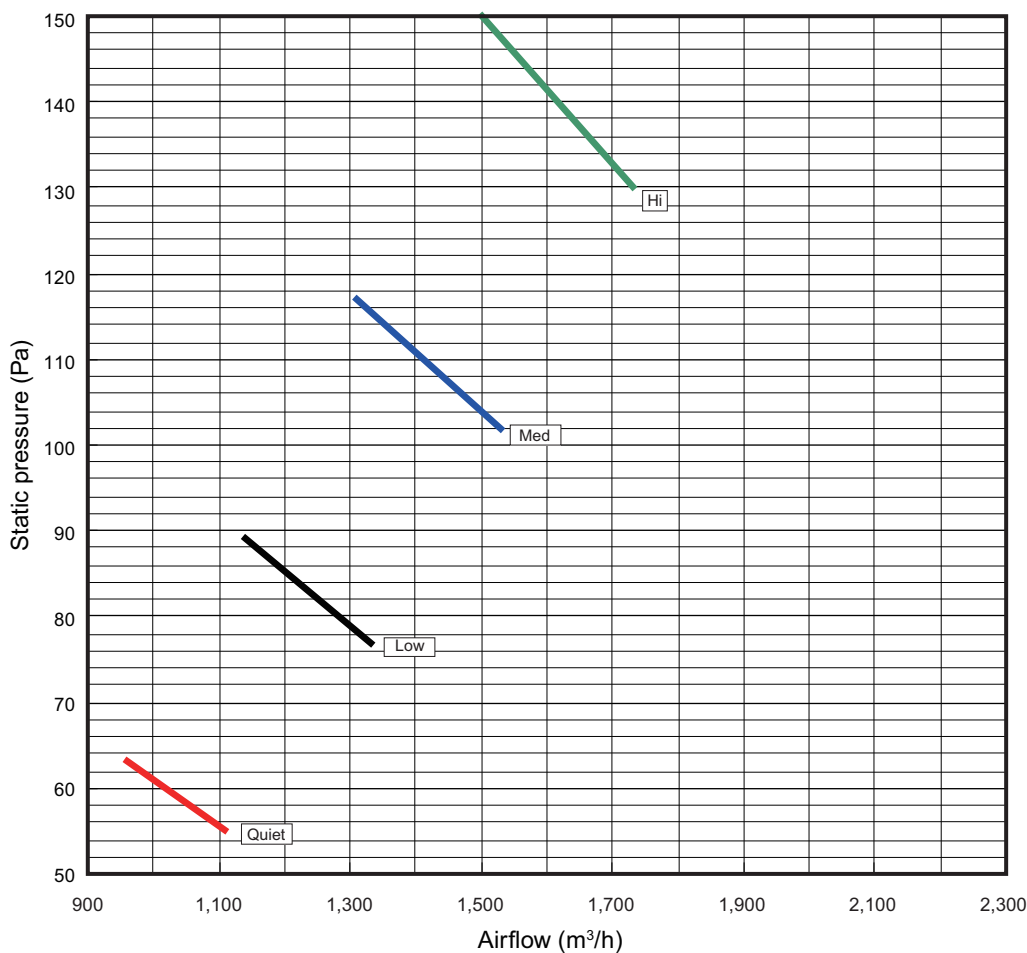

• Cooling

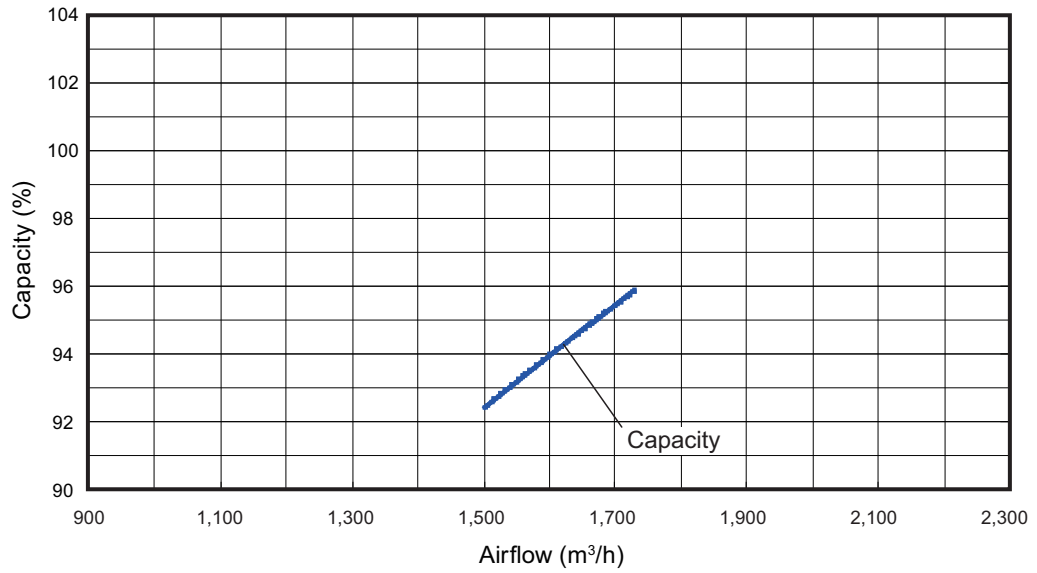

• Heating

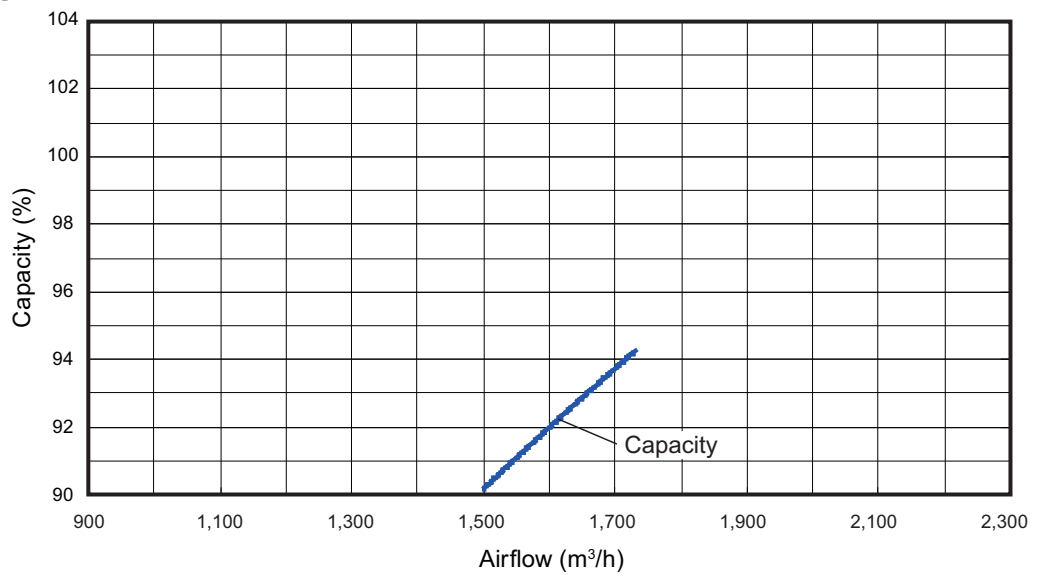

7. Airflow

Conversion factor:

- $1 \text{ m}^3/\text{h} = 0.2778 \text{ l/s} = 0.5886 \text{ CFM}$
- $3.6 \text{ m}^3/\text{h} = 1 \text{ l/s}$
- $1.699 \text{ m}^3/\text{h} = 1 \text{ CFM}$

7-1. Compact cassette type

■ Model: AUHG18LVLB (Standard ceiling mode)

● Cooling

Fan speed	Airflow	
HIGH	m^3/h	680
	l/s	189
	CFM	400
MED	m^3/h	580
	l/s	161
	CFM	341
LOW	m^3/h	490
	l/s	136
	CFM	288
QUIET	m^3/h	410
	l/s	114
	CFM	241

● Heating

Fan speed	Airflow	
HIGH	m^3/h	800
	l/s	222
	CFM	471
MED	m^3/h	680
	l/s	189
	CFM	400
LOW	m^3/h	580
	l/s	161
	CFM	341
QUIET	m^3/h	450
	l/s	125
	CFM	265

■ Model: AUHG18LVLB (High ceiling mode)

● Cooling

Fan speed	Airflow	
HIGH	m ³ /h	800
	l/s	222
	CFM	471
MED	m ³ /h	680
	l/s	189
	CFM	400
LOW	m ³ /h	590
	l/s	164
	CFM	347
QUIET	m ³ /h	410
	l/s	114
	CFM	241

● Heating

Fan speed	Airflow	
HIGH	m ³ /h	900
	l/s	250
	CFM	530
MED	m ³ /h	800
	l/s	222
	CFM	471
LOW	m ³ /h	680
	l/s	189
	CFM	400
QUIET	m ³ /h	450
	l/s	125
	CFM	265

■ Model: AUHG22LVLA (Standard ceiling mode)

● Cooling

Fan speed	Airflow	
HIGH	m ³ /h	930
	l/s	258
	CFM	547
MED	m ³ /h	830
	l/s	231
	CFM	488
LOW	m ³ /h	600
	l/s	167
	CFM	353
QUIET	m ³ /h	450
	l/s	125
	CFM	265

● Heating

Fan speed	Airflow	
HIGH	m ³ /h	930
	l/s	258
	CFM	547
MED	m ³ /h	860
	l/s	239
	CFM	506
LOW	m ³ /h	700
	l/s	194
	CFM	412
QUIET	m ³ /h	530
	l/s	147
	CFM	312

■ Model: AUHG22LVLA (High ceiling mode)

● Cooling

Fan speed	Airflow	
HIGH	m ³ /h	1,030
	l/s	286
	CFM	606
MED	m ³ /h	930
	l/s	258
	CFM	547
LOW	m ³ /h	710
	l/s	197
	CFM	418
QUIET	m ³ /h	450
	l/s	125
	CFM	265

● Heating

Fan speed	Airflow	
HIGH	m ³ /h	1,000
	l/s	278
	CFM	589
MED	m ³ /h	960
	l/s	267
	CFM	565
LOW	m ³ /h	820
	l/s	228
	CFM	483
QUIET	m ³ /h	530
	l/s	147
	CFM	312

■ Model: AUHG24LVLA (Standard ceiling mode)

● Cooling

Fan speed	Airflow	
HIGH	m ³ /h	930
	l/s	258
	CFM	547
MED	m ³ /h	830
	l/s	231
	CFM	488
LOW	m ³ /h	600
	l/s	167
	CFM	353
QUIET	m ³ /h	450
	l/s	125
	CFM	265

● Heating

Fan speed	Airflow	
HIGH	m ³ /h	930
	l/s	258
	CFM	547
MED	m ³ /h	860
	l/s	239
	CFM	506
LOW	m ³ /h	700
	l/s	194
	CFM	412
QUIET	m ³ /h	530
	l/s	147
	CFM	312

■ Model: AUHG24LVLA (High ceiling mode)

● Cooling

Fan speed	Airflow	
HIGH	m ³ /h	1,030
	l/s	286
	CFM	606
MED	m ³ /h	930
	l/s	258
	CFM	547
LOW	m ³ /h	710
	l/s	197
	CFM	418
QUIET	m ³ /h	450
	l/s	125
	CFM	265

● Heating

Fan speed	Airflow	
HIGH	m ³ /h	1,000
	l/s	278
	CFM	589
MED	m ³ /h	960
	l/s	267
	CFM	565
LOW	m ³ /h	820
	l/s	228
	CFM	483
QUIET	m ³ /h	530
	l/s	147
	CFM	312

7-2. Cassette type

■ Model: AUHG30LRLE (4-way air outlet)

● Cooling

Fan speed	Airflow	
HIGH	m ³ /h	1,600
	l/s	444
	CFM	942
MED	m ³ /h	1,400
	l/s	389
	CFM	824
LOW	m ³ /h	1,270
	l/s	353
	CFM	747
QUIET	m ³ /h	1,150
	l/s	319
	CFM	677

● Heating

Fan speed	Airflow	
HIGH	m ³ /h	1,600
	l/s	444
	CFM	942
MED	m ³ /h	1,400
	l/s	389
	CFM	824
LOW	m ³ /h	1,270
	l/s	353
	CFM	747
QUIET	m ³ /h	1,150
	l/s	319
	CFM	677

■ Model: AUHG30LRLE (3-way air outlet)

● Cooling

Fan speed	Airflow		
		Max.*	Min.*
HIGH	m ³ /h	1,550	1,350
	l/s	431	375
	CFM	912	794
MED	m ³ /h	1,350	1,200
	l/s	375	333
	CFM	794	706
LOW	m ³ /h	1,250	1,100
	l/s	347	306
	CFM	736	647
QUIET	m ³ /h	1,100	950
	l/s	306	264
	CFM	647	559

● Heating

Fan speed	Airflow		
		Max.*	Min.*
HIGH	m ³ /h	1,550	1,350
	l/s	431	375
	CFM	912	794
MED	m ³ /h	1,350	1,200
	l/s	375	333
	CFM	794	706
LOW	m ³ /h	1,250	1,100
	l/s	347	306
	CFM	736	647
QUIET	m ³ /h	1,100	950
	l/s	306	264
	CFM	647	559

*: Airflow can be changed according to the direction in which the outlet is blocked.

■ Model: AUHG36LRLE (4-way air outlet in low ceiling mode)

● Cooling

Fan speed	Airflow	
HIGH	m ³ /h	1,800
	l/s	500
	CFM	1,059
MED	m ³ /h	1,400
	l/s	389
	CFM	824
LOW	m ³ /h	1,270
	l/s	353
	CFM	747
QUIET	m ³ /h	1,150
	l/s	319
	CFM	677

● Heating

Fan speed	Airflow	
HIGH	m ³ /h	1,800
	l/s	500
	CFM	1,059
MED	m ³ /h	1,400
	l/s	389
	CFM	824
LOW	m ³ /h	1,270
	l/s	353
	CFM	747
QUIET	m ³ /h	1,150
	l/s	319
	CFM	677

■ Model: AUHG36LRLE (3-way air outlet)

● Cooling

Fan speed	Airflow		
		Max.*	Min.*
HIGH	m ³ /h	1,700	1,550
	l/s	472	431
	CFM	1,000	912
MED	m ³ /h	1,350	1,200
	l/s	375	333
	CFM	794	706
LOW	m ³ /h	1,250	1,100
	l/s	347	306
	CFM	736	647
QUIET	m ³ /h	1,100	950
	l/s	306	264
	CFM	647	559

● Heating

Fan speed	Airflow		
		Max.*	Min.*
HIGH	m ³ /h	1,700	1,550
	l/s	472	431
	CFM	1,000	912
MED	m ³ /h	1,350	1,200
	l/s	375	333
	CFM	794	706
LOW	m ³ /h	1,250	1,100
	l/s	347	306
	CFM	736	647
QUIET	m ³ /h	1,100	950
	l/s	306	264
	CFM	647	559

*: Airflow can be changed according to the direction in which the outlet is blocked.

■ Model: AUHG45LRLA (4-way air outlet)

● Cooling

Fan speed	Airflow	
HIGH	m ³ /h	1,900
	l/s	528
	CFM	1,118
MED	m ³ /h	1,640
	l/s	456
	CFM	965
LOW	m ³ /h	1,460
	l/s	406
	CFM	859
QUIET	m ³ /h	1,250
	l/s	347
	CFM	736

● Heating

Fan speed	Airflow	
HIGH	m ³ /h	1,900
	l/s	528
	CFM	1,118
MED	m ³ /h	1,640
	l/s	456
	CFM	965
LOW	m ³ /h	1,460
	l/s	406
	CFM	859
QUIET	m ³ /h	1,250
	l/s	347
	CFM	736

■ Model: AUHG45LRLA (3-way air outlet)

● Cooling

Fan speed	Airflow	
HIGH	m ³ /h	1,690
	l/s	469
	CFM	995
MED	m ³ /h	1,490
	l/s	414
	CFM	877
LOW	m ³ /h	1,340
	l/s	372
	CFM	789
QUIET	m ³ /h	1,140
	l/s	317
	CFM	671

● Heating

Fan speed	Airflow	
HIGH	m ³ /h	1,690
	l/s	469
	CFM	995
MED	m ³ /h	1,490
	l/s	414
	CFM	877
LOW	m ³ /h	1,340
	l/s	372
	CFM	789
QUIET	m ³ /h	1,140
	l/s	317
	CFM	671

7-3. Slim duct type

■ Model: ARHG18LLTB

● Cooling

Fan speed	Airflow	
HIGH	m ³ /h	940
	l/s	261
	CFM	553
MED	m ³ /h	880
	l/s	244
	CFM	518
LOW	m ³ /h	820
	l/s	227
	CFM	483
QUIET	m ³ /h	750
	l/s	208
	CFM	441

● Heating

Fan speed	Airflow	
HIGH	m ³ /h	940
	l/s	261
	CFM	553
MED	m ³ /h	880
	l/s	244
	CFM	518
LOW	m ³ /h	820
	l/s	227
	CFM	483
QUIET	m ³ /h	750
	l/s	208
	CFM	441

7-4. Duct type

■ Model: ARHG22LMLA

● Cooling

Fan speed	Airflow	
HIGH	m ³ /h	1,100
	l/s	306
	CFM	647
MED	m ³ /h	910
	l/s	253
	CFM	536
LOW	m ³ /h	750
	l/s	208
	CFM	441
QUIET	m ³ /h	580
	l/s	161
	CFM	341

● Heating

Fan speed	Airflow	
HIGH	m ³ /h	1,100
	l/s	306
	CFM	647
MED	m ³ /h	910
	l/s	253
	CFM	536
LOW	m ³ /h	750
	l/s	208
	CFM	441
QUIET	m ³ /h	580
	l/s	161
	CFM	341

■ Model: ARHG24LMLA

● Cooling

Fan speed	Airflow	
HIGH	m ³ /h	1,100
	l/s	306
	CFM	647
MED	m ³ /h	910
	l/s	253
	CFM	536
LOW	m ³ /h	750
	l/s	208
	CFM	441
QUIET	m ³ /h	580
	l/s	161
	CFM	341

● Heating

Fan speed	Airflow	
HIGH	m ³ /h	1,100
	l/s	306
	CFM	647
MED	m ³ /h	910
	l/s	253
	CFM	536
LOW	m ³ /h	750
	l/s	208
	CFM	441
QUIET	m ³ /h	580
	l/s	161
	CFM	341

■ Model: ARHG30LMLE

● Cooling

Fan speed	Airflow	
HIGH	m ³ /h	1,900
	l/s	528
	CFM	1,118
MED	m ³ /h	1,620
	l/s	450
	CFM	954
LOW	m ³ /h	1,270
	l/s	353
	CFM	748
QUIET	m ³ /h	980
	l/s	272
	CFM	577

● Heating

Fan speed	Airflow	
HIGH	m ³ /h	2,100
	l/s	583
	CFM	1,236
MED	m ³ /h	1,620
	l/s	450
	CFM	954
LOW	m ³ /h	1,270
	l/s	353
	CFM	748
QUIET	m ³ /h	980
	l/s	272
	CFM	577

■ Model: ARHG36LMLE

● Cooling

Fan speed	Airflow	
HIGH	m ³ /h	1,900
	l/s	528
	CFM	1,118
MED	m ³ /h	1,620
	l/s	450
	CFM	954
LOW	m ³ /h	1,270
	l/s	353
	CFM	748
QUIET	m ³ /h	980
	l/s	272
	CFM	577

● Heating

Fan speed	Airflow	
HIGH	m ³ /h	2,100
	l/s	583
	CFM	1,236
MED	m ³ /h	1,620
	l/s	450
	CFM	954
LOW	m ³ /h	1,270
	l/s	353
	CFM	748
QUIET	m ³ /h	980
	l/s	272
	CFM	577

■ Model: ARHG45LMLA

● Cooling

Fan speed	Airflow	
HIGH	m ³ /h	2,100
	l/s	583
	CFM	1,236
MED	m ³ /h	1,750
	l/s	486
	CFM	1,030
LOW	m ³ /h	1,350
	l/s	375
	CFM	795
QUIET	m ³ /h	1,070
	l/s	297
	CFM	630

● Heating

Fan speed	Airflow	
HIGH	m ³ /h	2,100
	l/s	583
	CFM	1,236
MED	m ³ /h	1,750
	l/s	486
	CFM	1,030
LOW	m ³ /h	1,350
	l/s	375
	CFM	795
QUIET	m ³ /h	1,070
	l/s	297
	CFM	630

7-5. Floor/Ceiling type

■ Model: ABHG18LVTB

● Cooling

Fan speed	Airflow	
HIGH	m ³ /h	780
	l/s	217
	CFM	459
MED	m ³ /h	700
	l/s	194
	CFM	412
LOW	m ³ /h	560
	l/s	156
	CFM	330
QUIET	m ³ /h	500
	l/s	139
	CFM	294

● Heating

Fan speed	Airflow	
HIGH	m ³ /h	780
	l/s	217
	CFM	459
MED	m ³ /h	700
	l/s	194
	CFM	412
LOW	m ³ /h	560
	l/s	156
	CFM	330
QUIET	m ³ /h	500
	l/s	139
	CFM	294

■ Model: ABHG22LVTA

● Cooling

Fan speed	Airflow	
HIGH	m ³ /h	980
	l/s	272
	CFM	577
MED	m ³ /h	820
	l/s	228
	CFM	483
LOW	m ³ /h	680
	l/s	189
	CFM	400
QUIET	m ³ /h	540
	l/s	150
	CFM	318

● Heating

Fan speed	Airflow	
HIGH	m ³ /h	980
	l/s	272
	CFM	577
MED	m ³ /h	820
	l/s	228
	CFM	483
LOW	m ³ /h	680
	l/s	189
	CFM	400
QUIET	m ³ /h	540
	l/s	150
	CFM	318

■ Model: ABHG24LVTA

● Cooling

Fan speed	Airflow	
HIGH	m ³ /h	980
	l/s	272
	CFM	577
MED	m ³ /h	820
	l/s	228
	CFM	483
LOW	m ³ /h	680
	l/s	189
	CFM	400
QUIET	m ³ /h	540
	l/s	150
	CFM	318

● Heating

Fan speed	Airflow	
HIGH	m ³ /h	980
	l/s	272
	CFM	577
MED	m ³ /h	820
	l/s	228
	CFM	483
LOW	m ³ /h	680
	l/s	189
	CFM	400
QUIET	m ³ /h	540
	l/s	150
	CFM	318

7-6. Ceiling type

■ Model: ABHG30LRTE

● Cooling

Fan speed	Airflow	
HIGH	m ³ /h	1,660
	l/s	461
	CFM	977
MED	m ³ /h	1,500
	l/s	417
	CFM	883
LOW	m ³ /h	1,200
	l/s	333
	CFM	706
QUIET	m ³ /h	1,000
	l/s	278
	CFM	589

● Heating

Fan speed	Airflow	
HIGH	m ³ /h	1,660
	l/s	461
	CFM	977
MED	m ³ /h	1,500
	l/s	417
	CFM	883
LOW	m ³ /h	1,200
	l/s	333
	CFM	706
QUIET	m ³ /h	1,000
	l/s	278
	CFM	589

■ Model: ABHG36LRTE

● Cooling

Fan speed	Airflow	
HIGH	m ³ /h	1,900
	l/s	528
	CFM	1,118
MED	m ³ /h	1,500
	l/s	417
	CFM	883
LOW	m ³ /h	1,200
	l/s	333
	CFM	706
QUIET	m ³ /h	1,000
	l/s	278
	CFM	589

● Heating

Fan speed	Airflow	
HIGH	m ³ /h	1,900
	l/s	528
	CFM	1,118
MED	m ³ /h	1,500
	l/s	417
	CFM	883
LOW	m ³ /h	1,200
	l/s	333
	CFM	706
QUIET	m ³ /h	1,000
	l/s	278
	CFM	589

■ Model: ABHG45LRTA

● Cooling

Fan speed	Airflow	
HIGH	m ³ /h	2,100
	l/s	583
	CFM	1,236
MED	m ³ /h	1,700
	l/s	472
	CFM	1,000
LOW	m ³ /h	1,400
	l/s	389
	CFM	824
QUIET	m ³ /h	1,100
	l/s	306
	CFM	647

● Heating

Fan speed	Airflow	
HIGH	m ³ /h	2,100
	l/s	583
	CFM	1,236
MED	m ³ /h	1,700
	l/s	472
	CFM	1,000
LOW	m ³ /h	1,400
	l/s	389
	CFM	824
QUIET	m ³ /h	1,100
	l/s	306
	CFM	647

8. Noise level curve

8-1. Compact cassette type

Model: AUHG18LVLB

Cooling

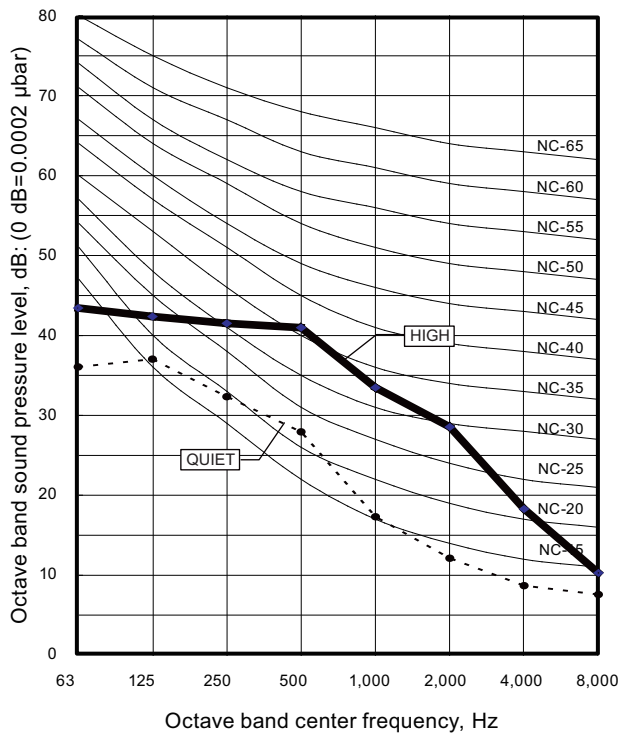

Heating

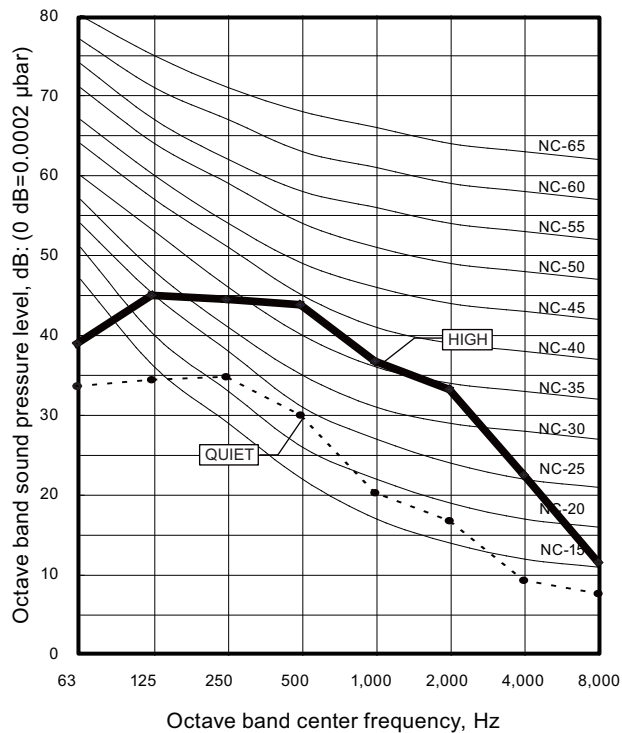

Model: AUHG22LVLA

Cooling

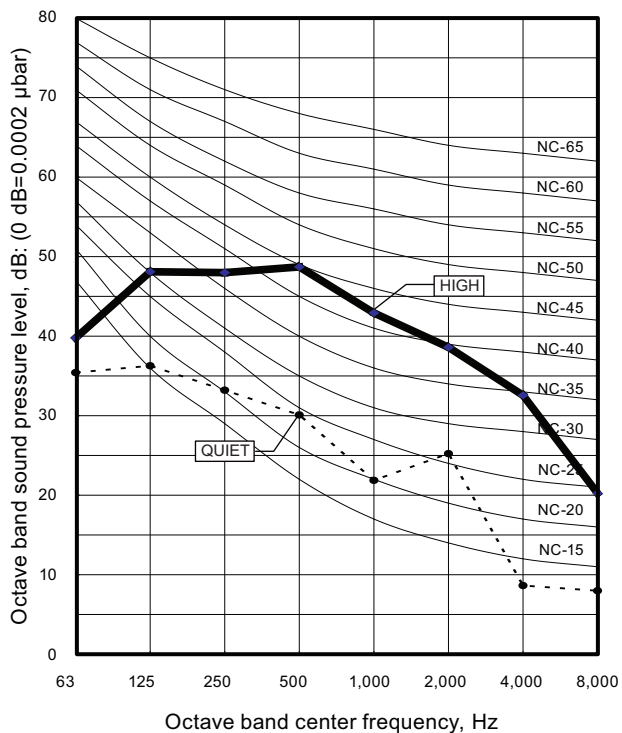

Heating

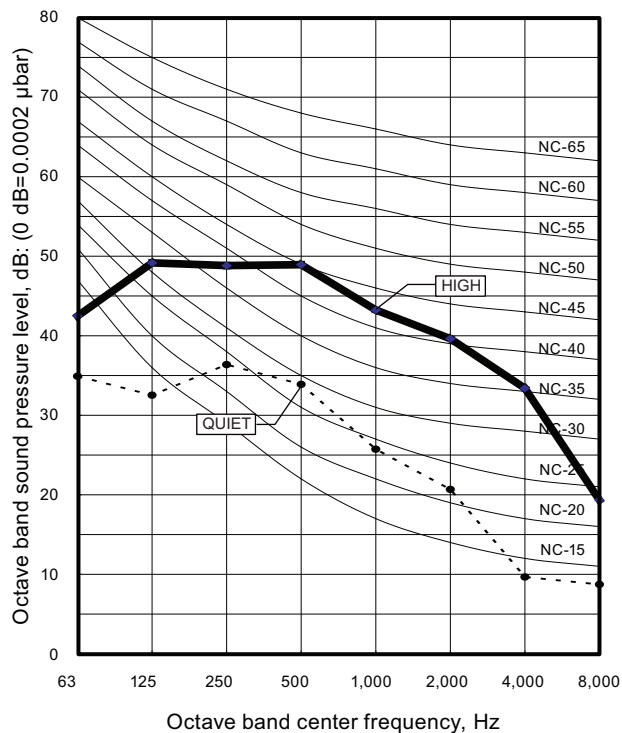

Model: AUHG24LVLA

● Cooling

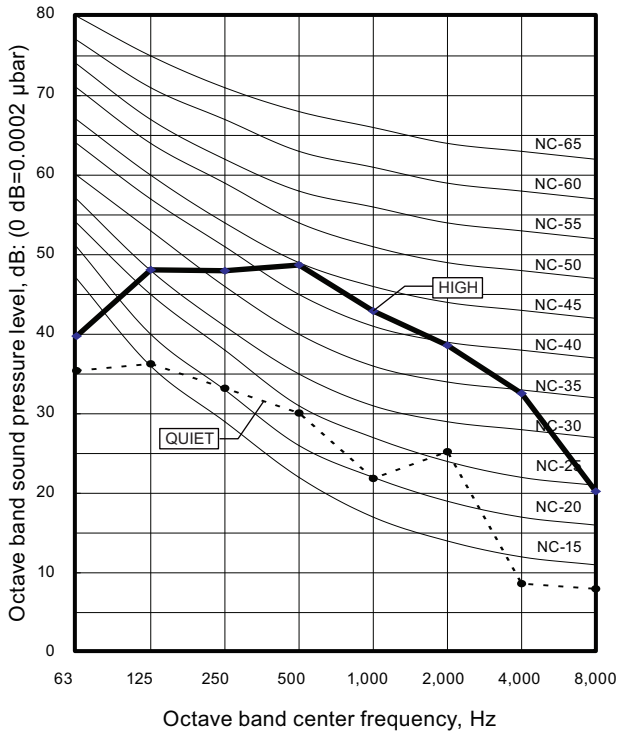

● Heating

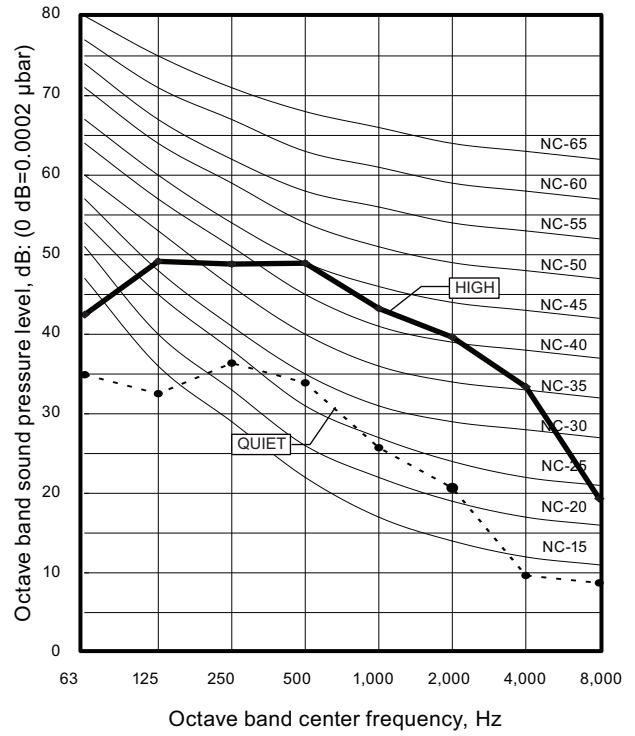

8-2. Cassette type

Model: AUHG30LRLE

● Cooling

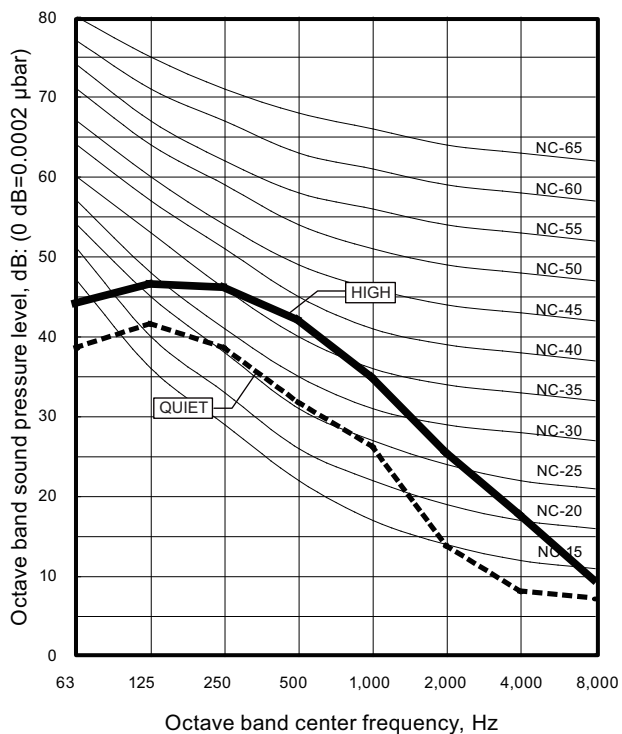

● Heating

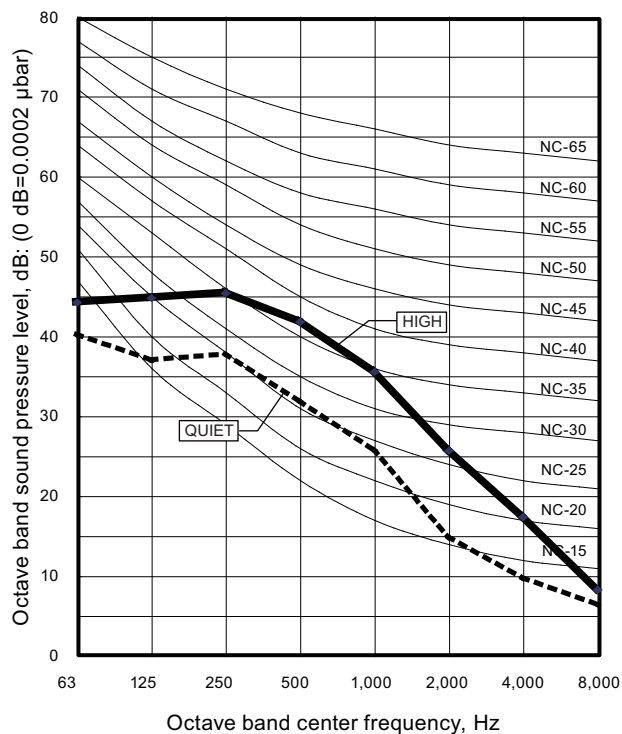

Model: AUHG36LRLE

● Cooling

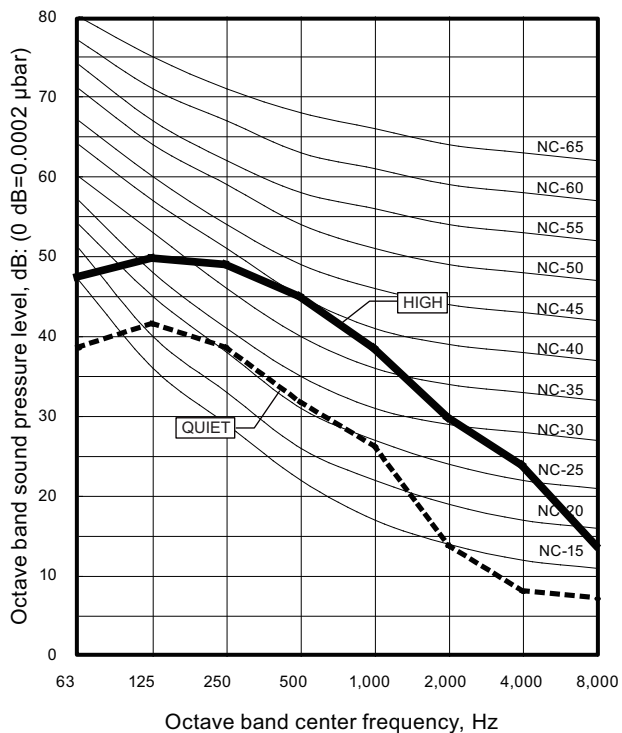

● Heating

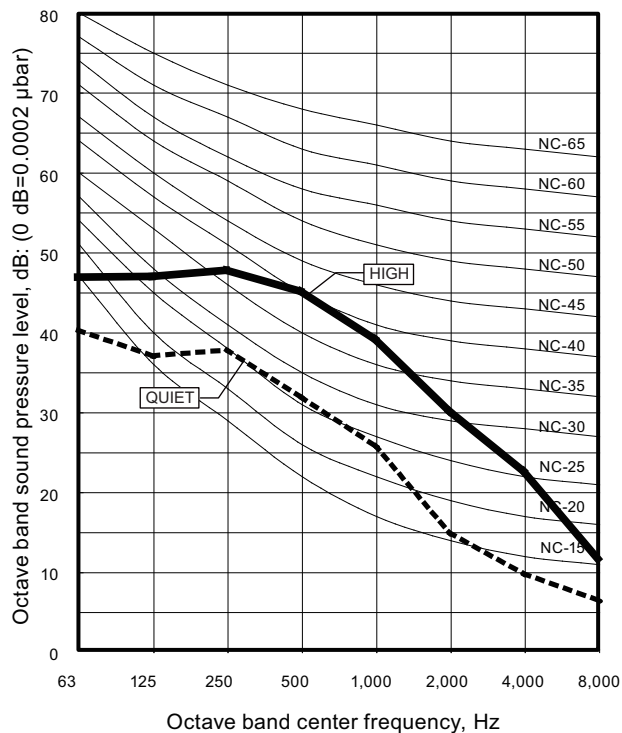

■ Model: AUHG45LRLA

● Cooling

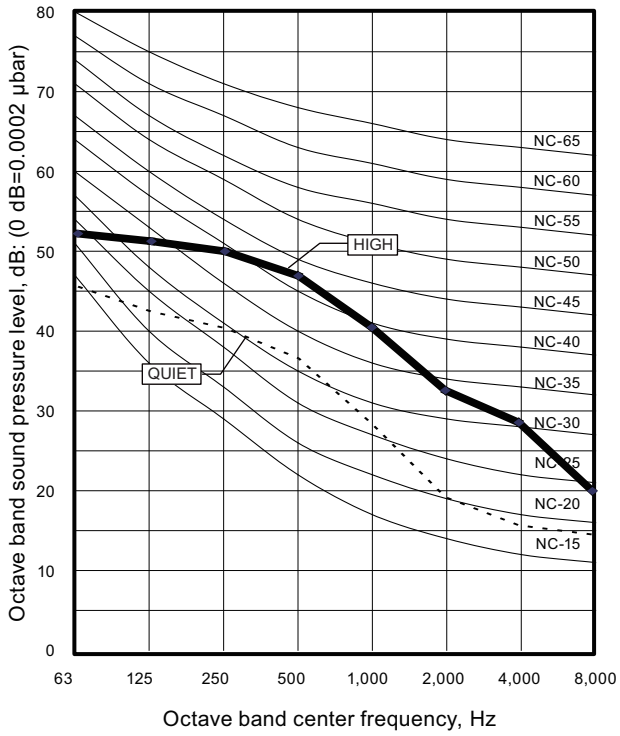

● Heating

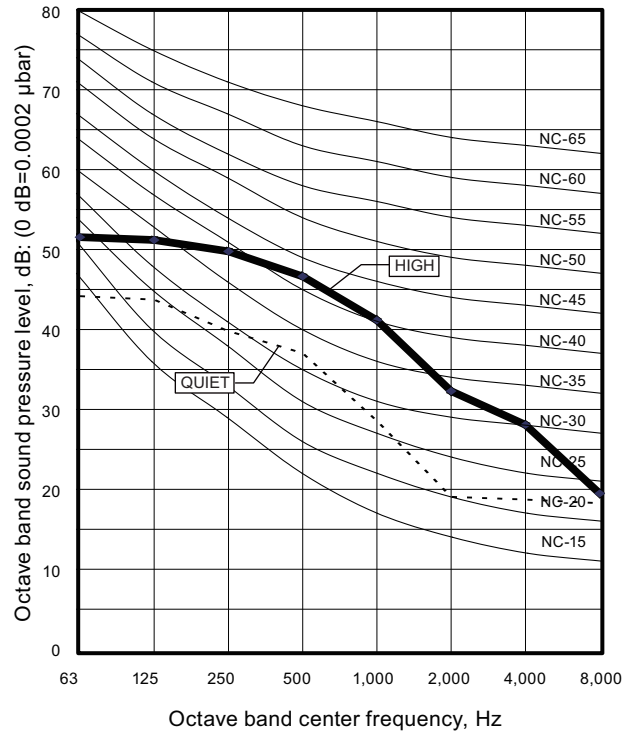

8-3. Slim duct type

Model: ARHG18LLTB

● Cooling

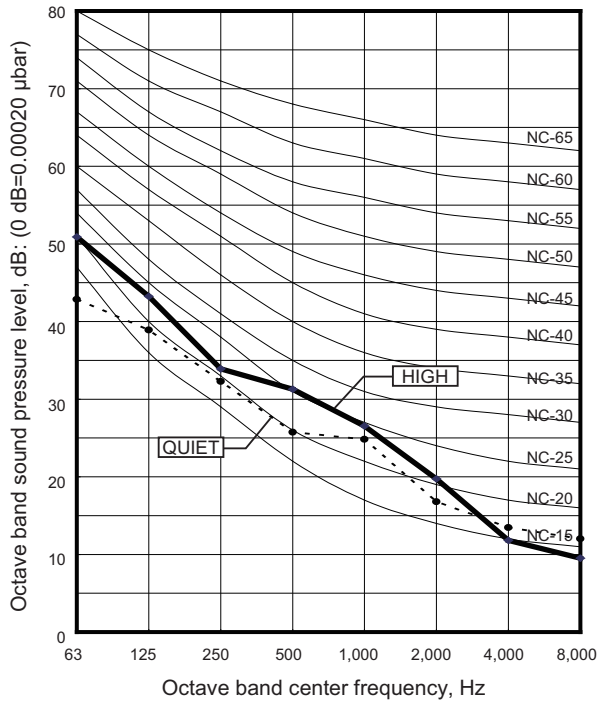

● Heating

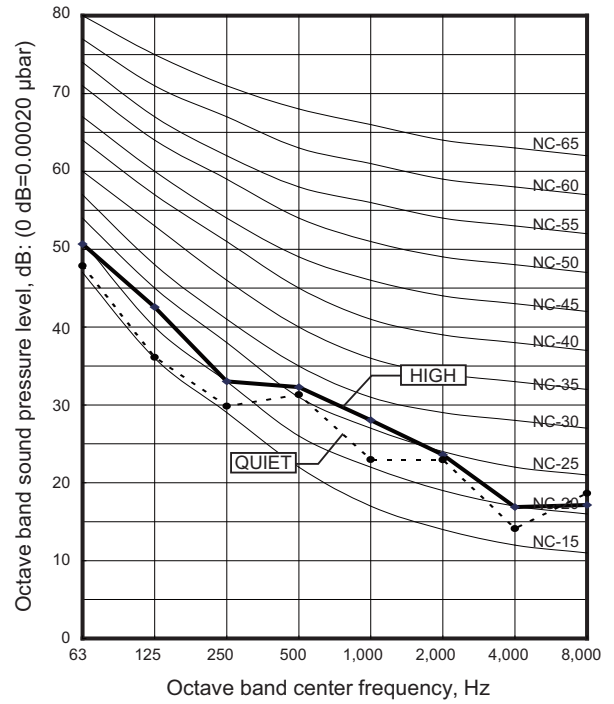

8-4. Duct type

Model: ARHG22LMLA

Cooling

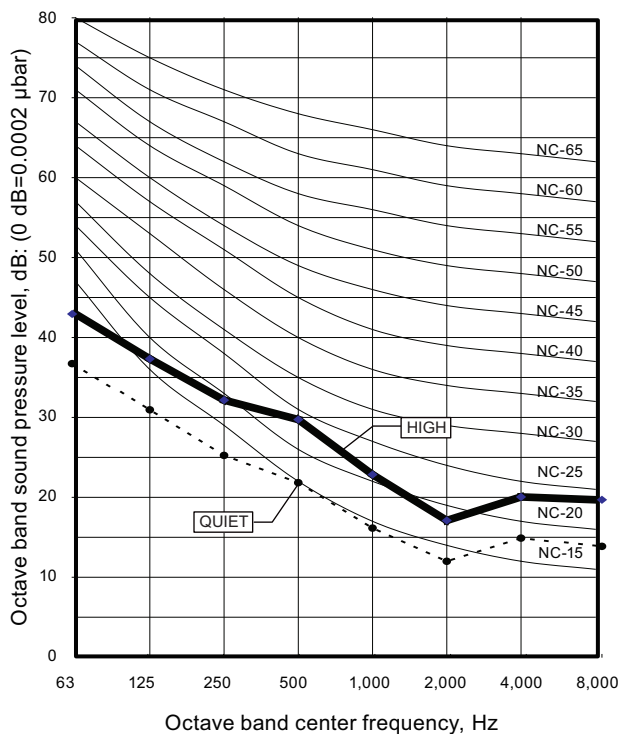

Heating

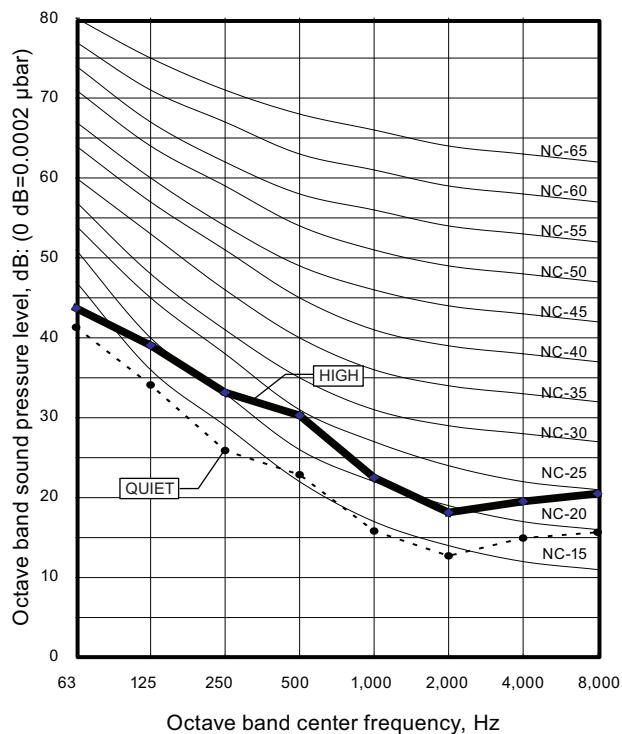

Model: ARHG24LMLA

Cooling

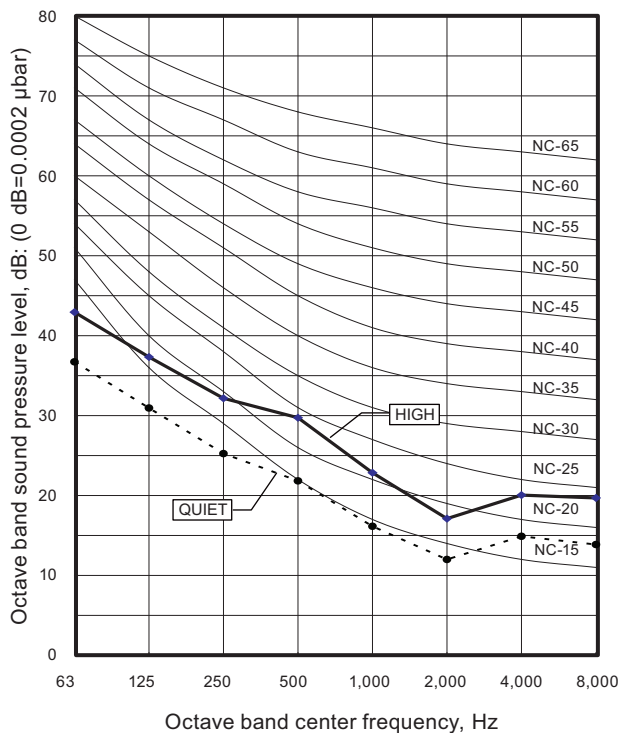

Heating

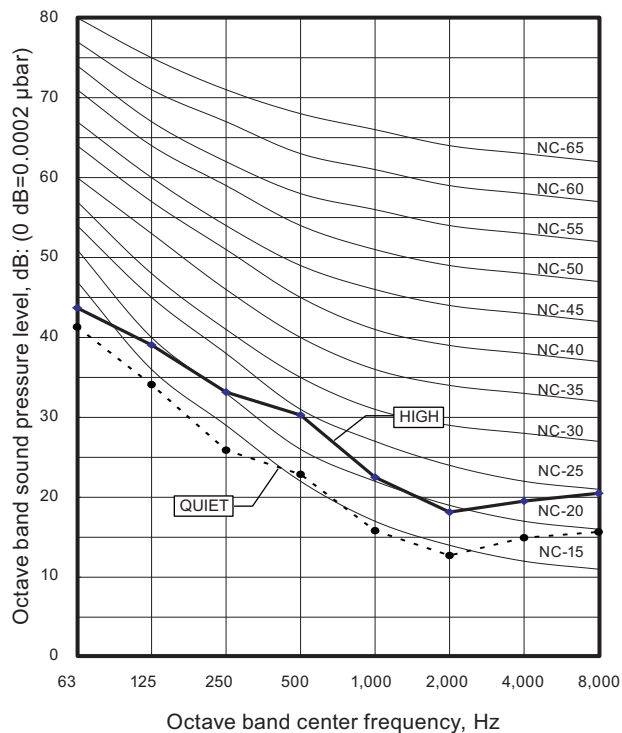

Model: ARHG30LMLE

Cooling

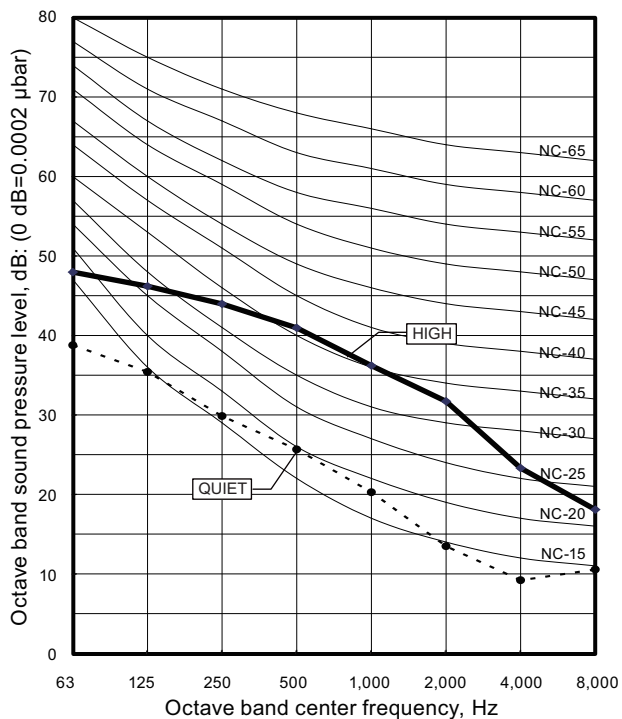

Heating

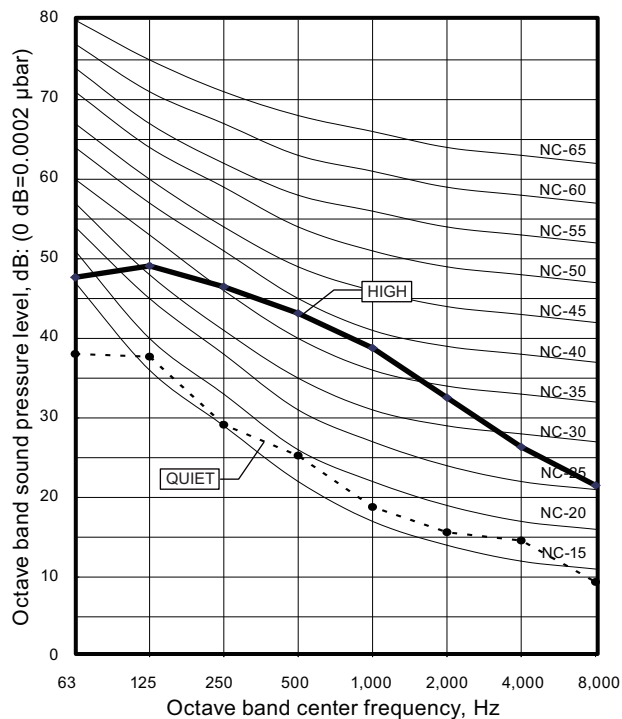

Model: ARHG36LMLE

Cooling

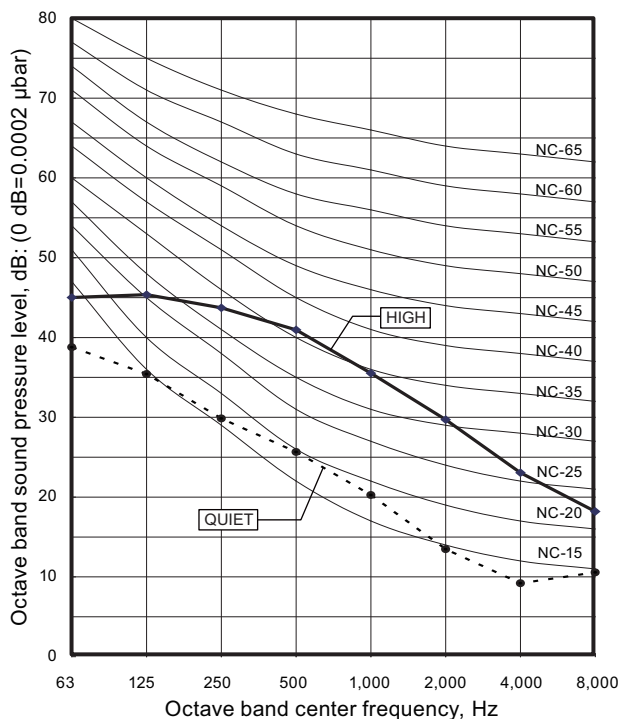

Heating

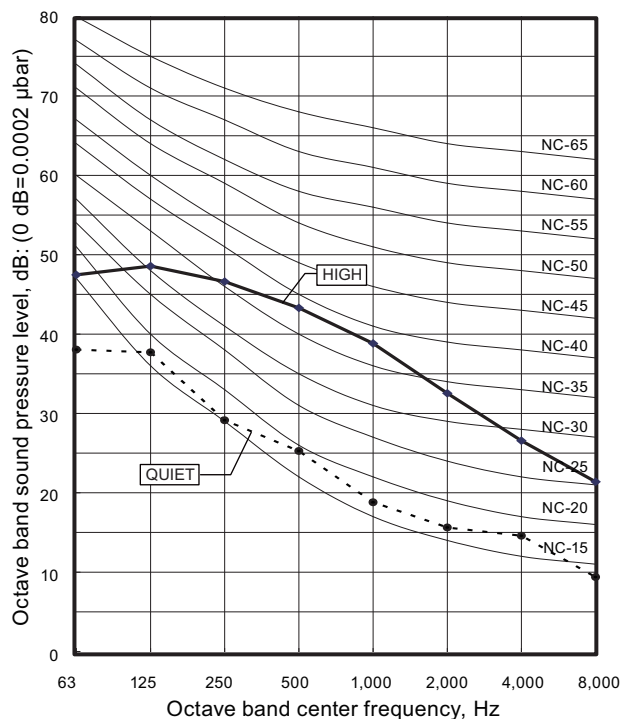

Model: ARHG45LMLA

● Cooling

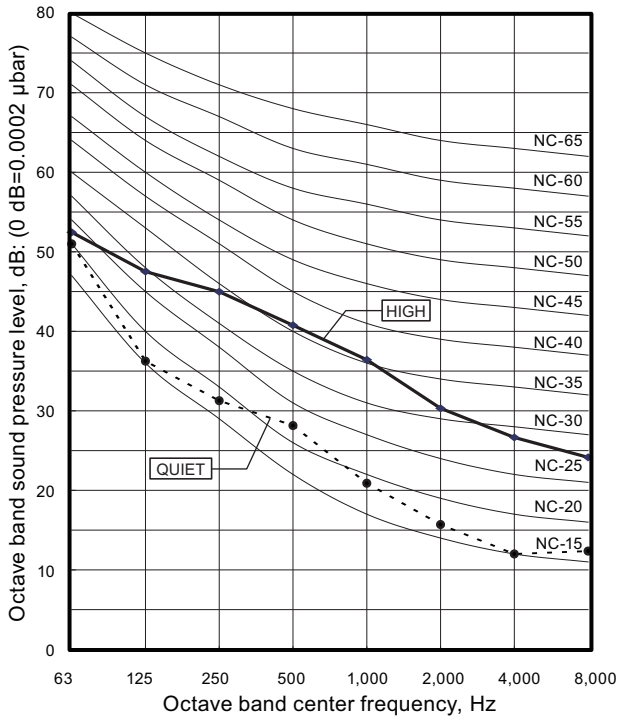

● Heating

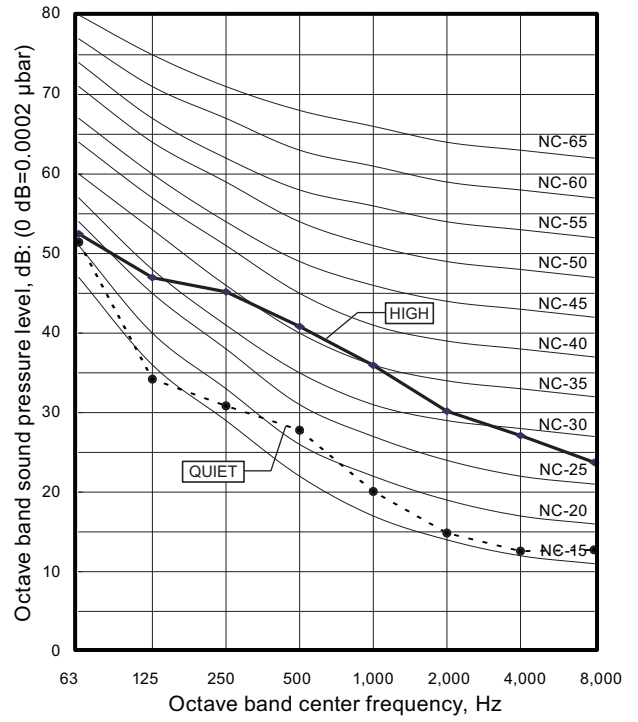

8-5. Floor/Ceiling type

Model: ABHG18LVTB

Cooling

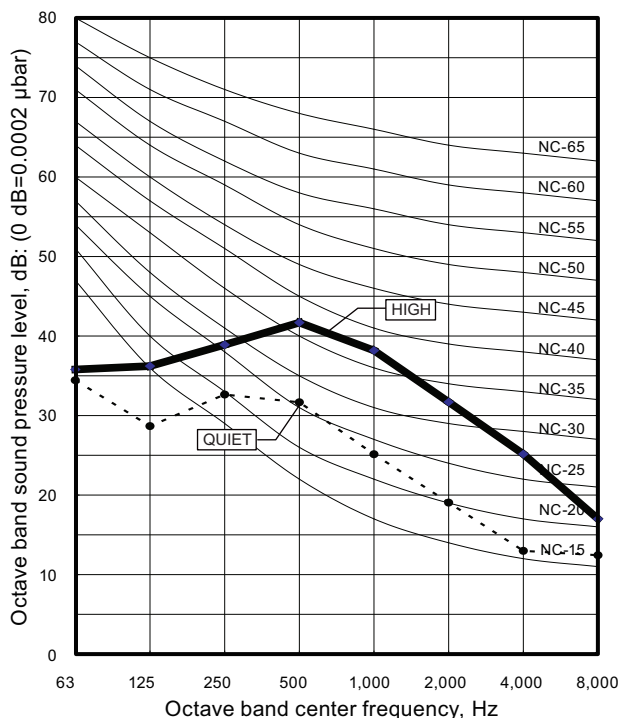

Heating

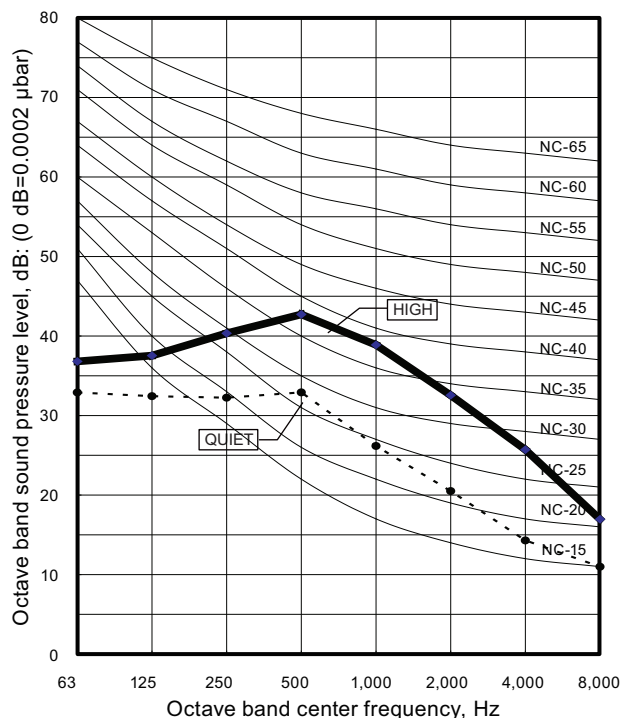

Model: ABHG22LVTA

Cooling

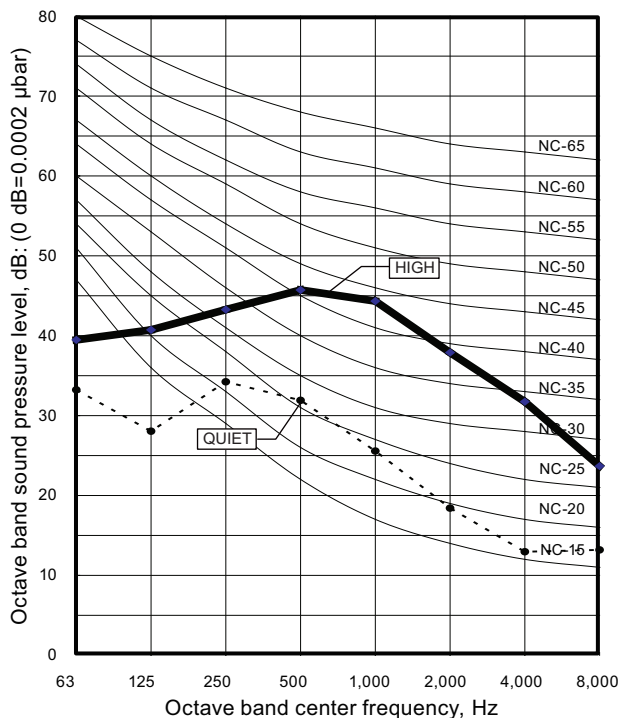

Heating

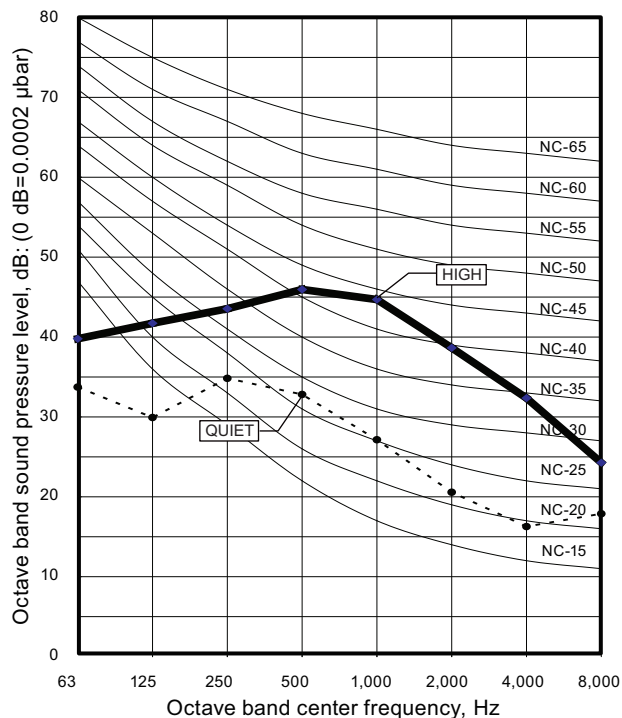

Model: ABHG24LVTA

● Cooling

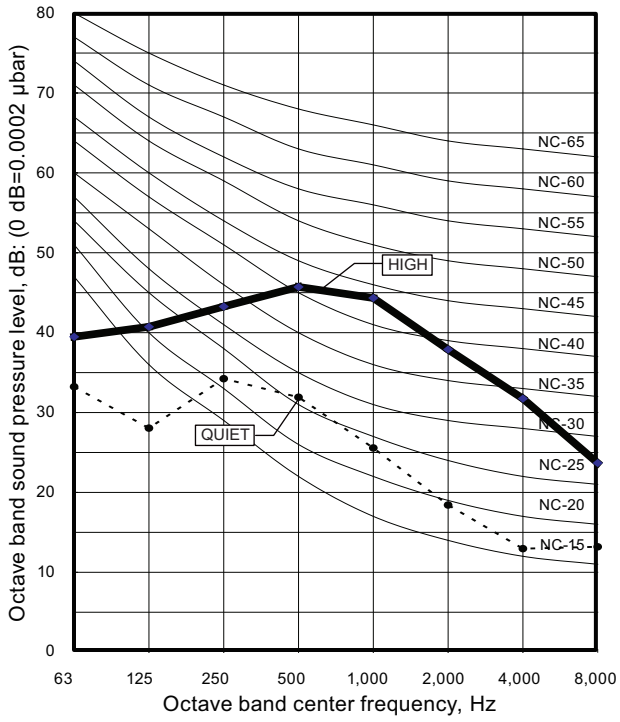

● Heating

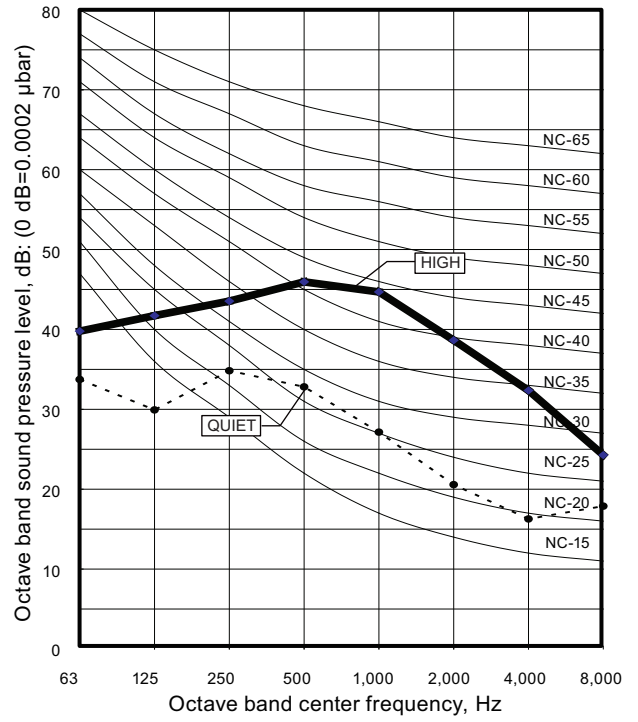

8-6. Ceiling type

Model: ABHG30LRTE

Cooling

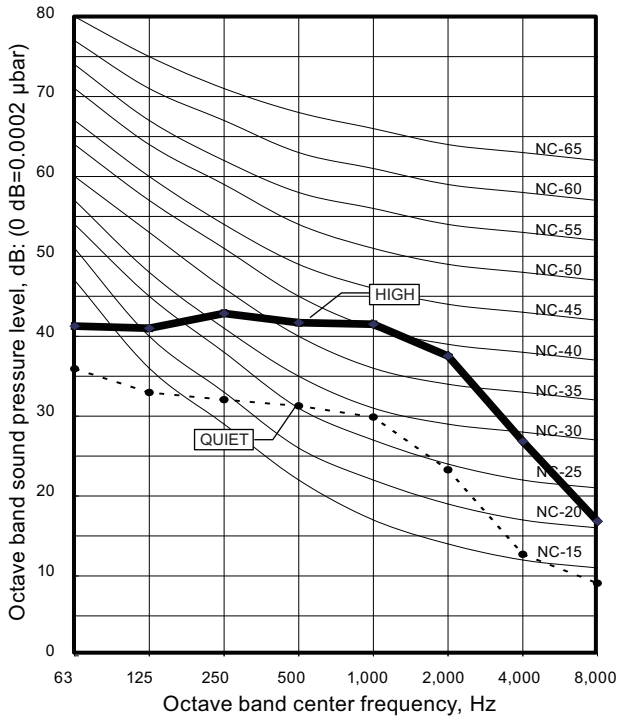

Heating

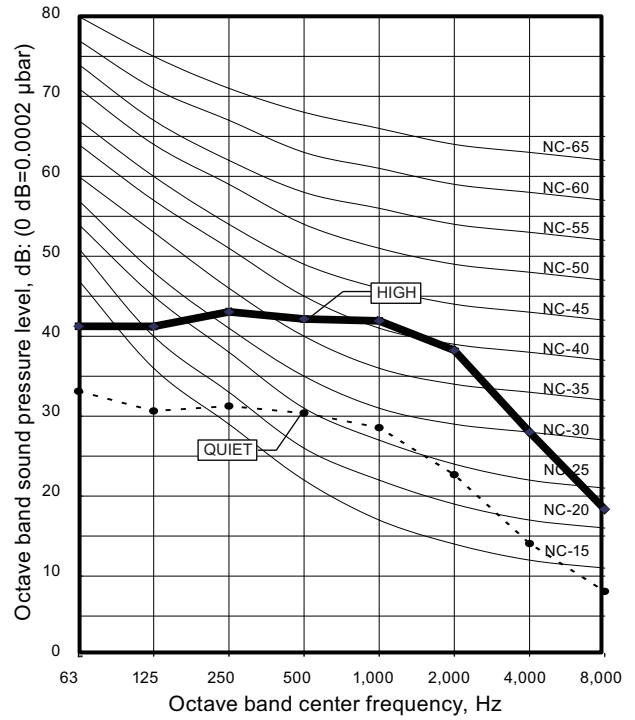

Model: ABHG36LRTE

Cooling

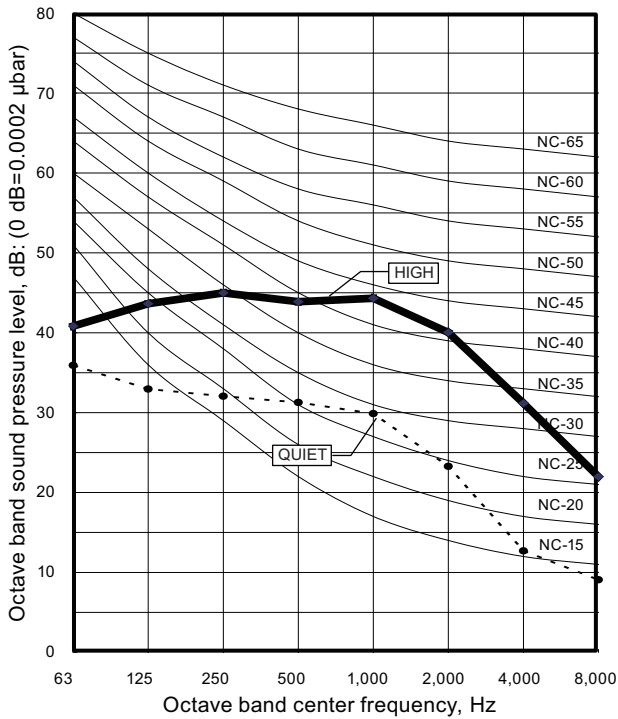

Heating

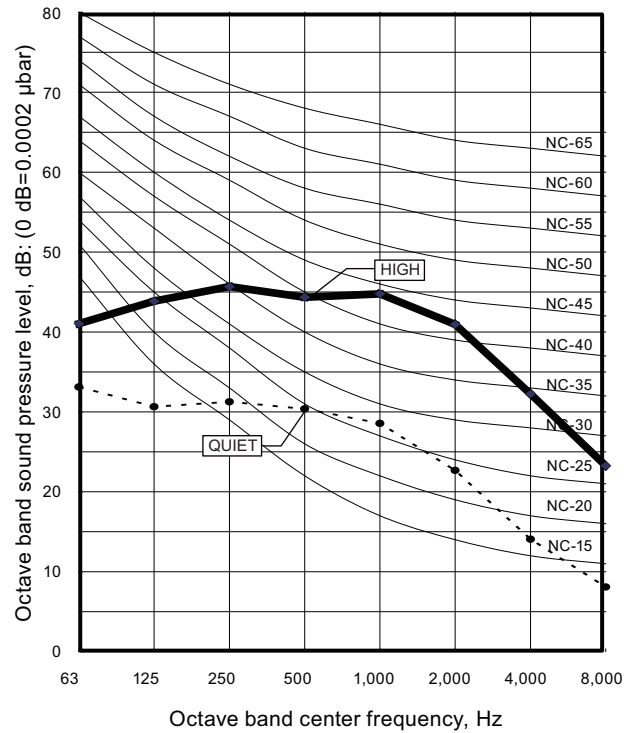

■ Model: ABHG45LRTA

● Cooling

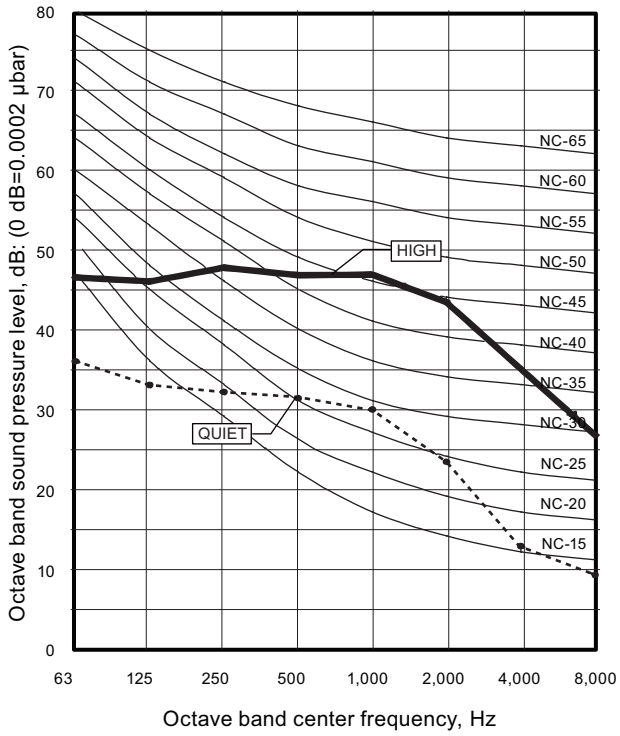

● Heating

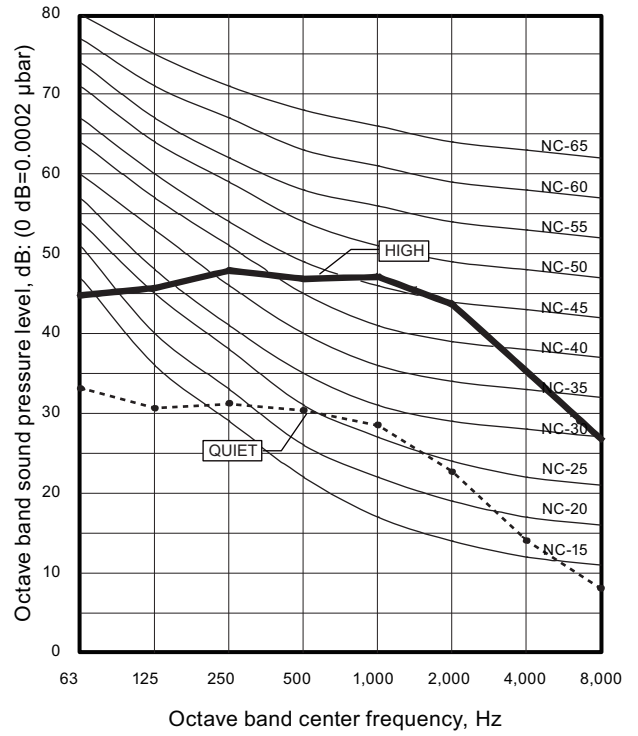

8-7. Sound level check point

■ Compact cassette type

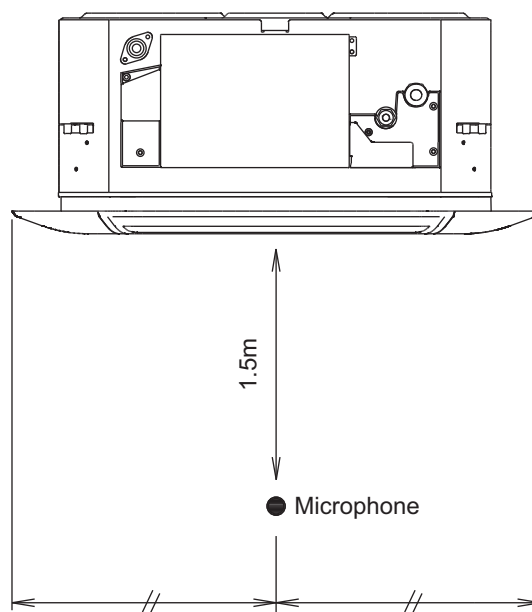
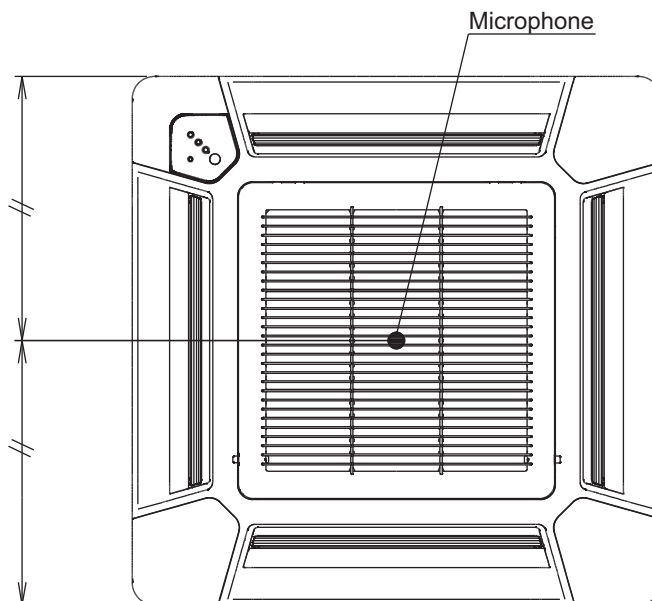

■ Cassette type

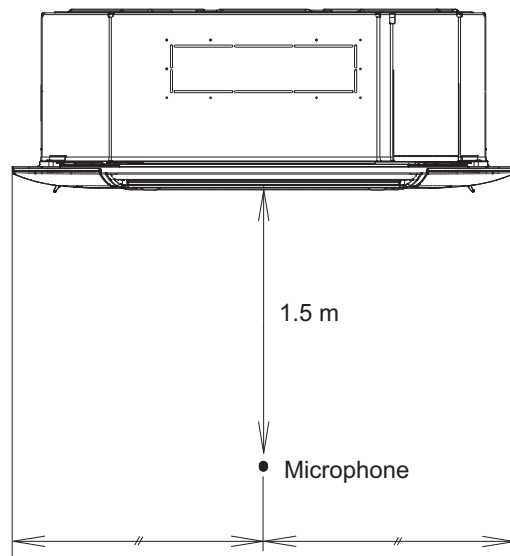
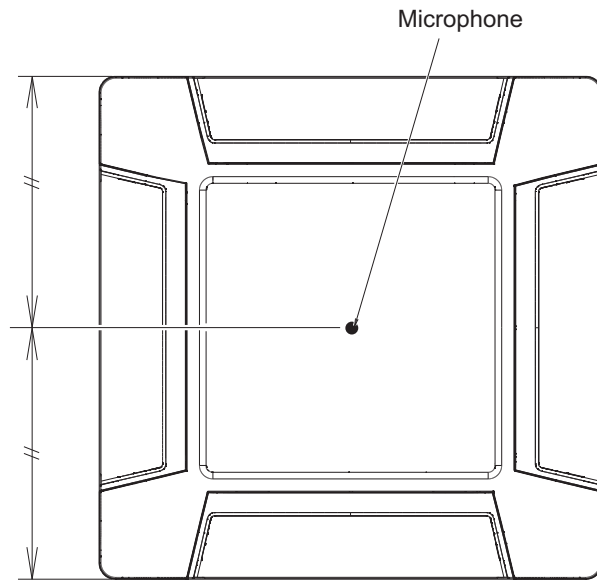

■ Slim duct type

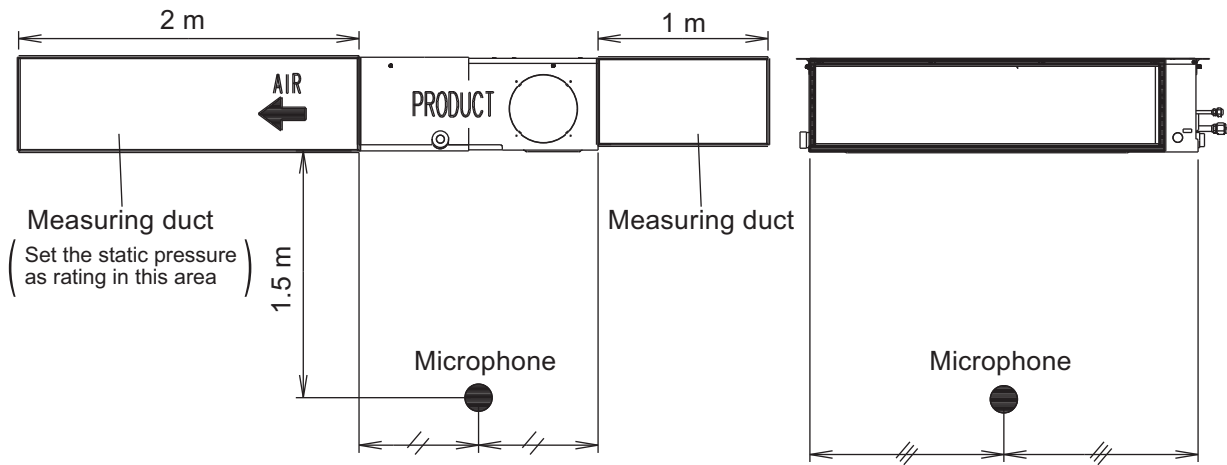

Side view

Front view

■ Duct type

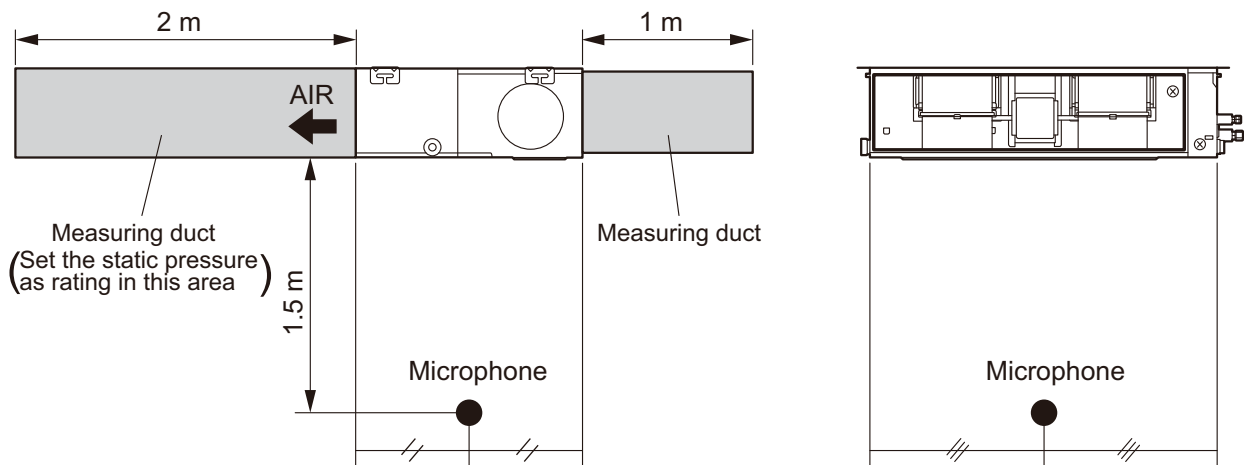

■ Floor/Ceiling type

• Floor console

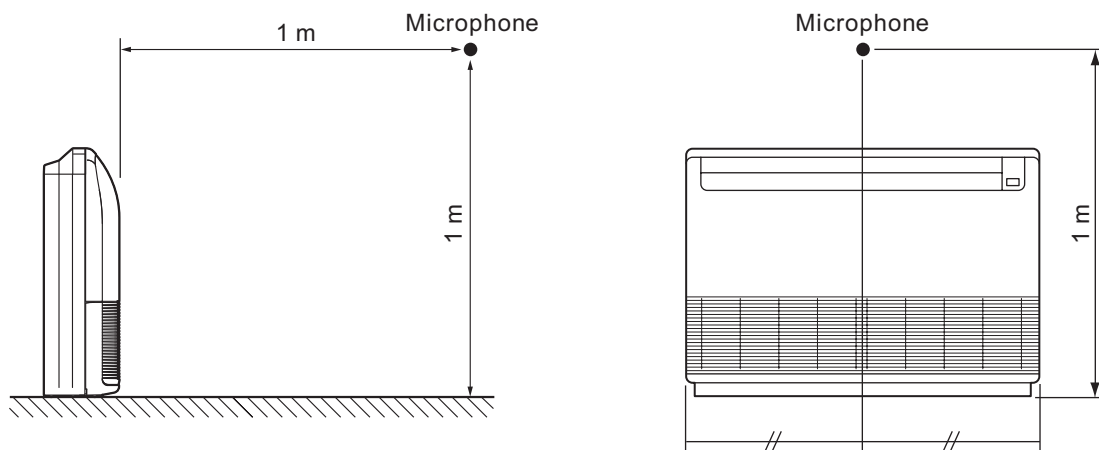

• Under ceiling

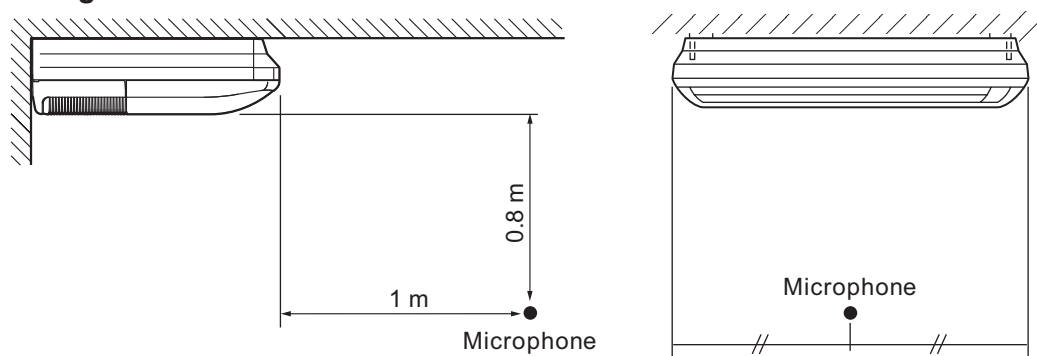

■ Ceiling type

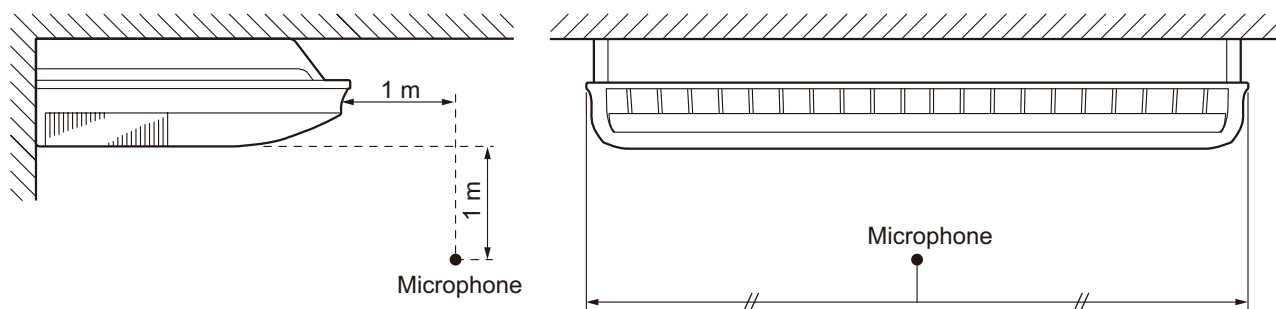

9. Electrical characteristics

Indoor unit		Power supply			Wiring specification *1 (Total *2)
Type	Model name	Frequency (Hz)	Voltage (V)	MCA (A)	Connection cable (mm ²)
Compact cassette	AUHG18LVLB	230	50	0.2	1.5
	AUHG22LVLA			0.3	
	AUHG24LVLA			0.3	
Cassette	AUHG30LRLE			0.7	
	AUHG36LRLE			0.7	
	AUHG45LRLA			1.2	
Slim duct	ARHG18LLTB			0.5	
Duct	ARHG22LMLA			0.7	
	ARHG24LMLA			0.7	
	ARHG30LMLE			2.0	
	ARHG36LMLE			2.0	
	ARHG45LMLA			2.1	
Floor/ Ceiling	ABHG18LVTB			0.5	
	ABHG22LVTA			0.7	
	ABHG24LVTA			0.7	
Ceiling	ABHG30LRTE	0.7			
	ABHG36LRTE	0.7			
	ABHG45LRTE	0.8			

MCA: Minimum Circuit Amperes = Maximum operating current (Full load)

NOTES:

- *1: Selected sample based on Japan Electrotechnical Standards and Codes Committee E0005. As the regulations of wire size and circuit breaker differ in each country or region, select appropriate devices complied to the regional standard.
- *2: Total length of all wirings that interconnect between indoor units and between indoor unit and outdoor unit.

10. Safety devices











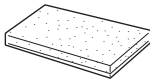
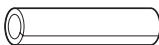

Indoor unit		PCB* fuse	Fan motor thermal protector		
Type	Model name		Activate	Reset	
Compact cassette	AUHG18LVLB	250 V, 3.15 A	100±10 °C Fan motor stop	95±10 °C Fan motor restart	
	AUHG22LVLA				
	AUHG24LVLA				
Cassette	AUHG30LRLE		250 V, 5 A	125±10 °C Fan motor stop	120±10 °C Fan motor restart
	AUHG36LRLE				
	AUHG45LRLA				
Slim duct	ARHG18LLTB	250 V, 3.15 A		135±15 °C Fan motor stop	115±15 °C Fan motor restart
Duct	ARHG22LMLA				
	ARHG24LMLA				
	ARHG30LMLE				
	ARHG36LMLE				
	ARHG45LMLA				
Floor/Ceiling	ABHG18LVTB	250 V, 3.15 A	135±15 °C Fan motor stop	115±15 °C Fan motor restart	
	ABHG22LVTA				
	ABHG24LVTA				
Ceiling	ABHG30LRTE		250 V, 3.15 A	135±15 °C Fan motor stop	115±15 °C Fan motor restart
	ABHG36LRTE				
	ABHG45LRTE				

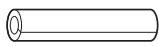
*: Printed Circuit Board

11. Accessories



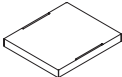

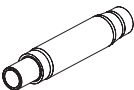
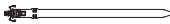







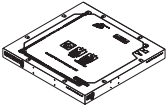

11-1. Compact cassette type

■ Models: AUHG18LVLB, AUHG22LVLA, and AUHG24LVLA

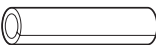
Part name	Exterior	Q'ty	Part name	Exterior	Q'ty
Operating manual		1	Hose band		1
Installation manual		1	Drain hose insulation		1
Coupler heat insulation (Large)		1	Remote controller		1
Coupler heat insulation (Small)		1	Remote controller holder		1
Special nut A (Large flange)		4	Battery		2
Special nut B (Small flange)		4	Tapping screw		2
Template (Carton top)		1	Cable tie		2
Drain hose		1	Wire clammer		1

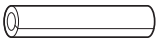

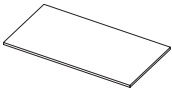

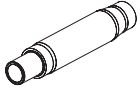







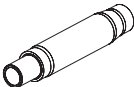

11-2. Cassette type

■ Models: AUHG30LRLE, AUHG36LRLE, and AUHG45LRLE

Part name	Exterior	Q'ty	Part name	Exterior	Q'ty
Operating manual		1	Hose band		1
Installation manual		1	Drain hose heat insulation		1
Template (Carton top)		1	Cable tie (Large)		3
Washer		8	Cable tie (Small)		1
Coupler heat insulation (Large)		1	Wired remote controller		1
Coupler heat insulation (Small)		1	Remote controller cable		1
Insulation		1	Tapping screw		2
Drain hose		1			











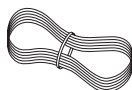
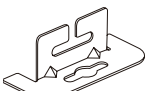

11-3. Slim duct type

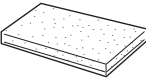
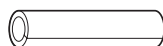
■ Model: ARHG18LLTB

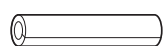
Part name	Exterior	Q'ty	Part name	Exterior	Q'ty
Operating manual		1	Cable tie (Large)		4
Installation manual		1	Cable tie (Medium)		3
Installation template		1	Drain hose		1
Washer		8	Hose band		1
Coupler heat insulation (Large)		1	Drain hose insulation B		1
Coupler heat insulation (Small)		1	Remote controller		1
Filter (Large)		2	Remote controller cable		1
Tapping screw (M4 × 16 mm)		2			



















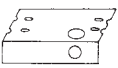

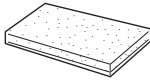

11-4. Duct type

■ Models: ARHG22LMLA, ARHG24LMLA, ARHG30LMLE, ARHG36LMLE, and ARHG45LMLA

Part name	Exterior	Q'ty	Part name	Exterior	Q'ty
Operating manual		1	Wired remote controller		1
Installation manual		1	Remote controller cable		1
Hanger		4	Tapping screw		2
Drain hose insulation		1	Coupler heat insulation (Large)		1
Cable tie (Large)		1	Coupler heat insulation (Small)		1
Cable tie (Small)		1	M10 nut A (with flange)		4
Cable tie (For 22 and 24 models)		2	M10 nut B (with spring lock washer)		4
Wire clamber (For 22 and 24 models)		1			

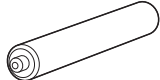
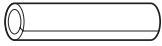

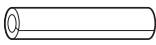









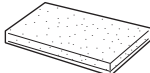

11-5. Floor/Ceiling type

■ Models: ABHG18LVTB, ABHG22LVTA, and ABHG24LVTA

Part name	Exterior	Q'ty	Part name	Exterior	Q'ty
Operating manual		1	M10 nut A (with flange) For suspending the indoor unit from ceiling		4
Installation manual		1	Cable tie (Large) For fixing the drain hose		1
Cover plate (Left)		1	Cable tie (Small) For electrical wiring		2
Cover plate (Right)		1	Wire clammer For electrical wiring		1
Installation template Positioning for under ceiling type		1	Drain hose		1
Bracket (Left) For suspending the indoor unit from ceiling		1	Drain hose insulation Adhesive type 100 × 220 mm		1
Bracket (Right) For suspending the indoor unit from ceiling		1	Hose band For installing drain hose		1
Wall bracket For suspending the indoor unit on the wall		2	VT wire For fixing the drain hose L = 280 mm		1
Screw (M4 x 10 mm) For the cover plate (left/ right)		2	Remote controller		1
Tapping screw (large) For fixing the wall bracket		6	Battery		2
Coupler heat insulator (Large) For indoor side pipe joint (Large pipe)		1	Remote controller holder		1
Coupler heat insulator (Small) For indoor side pipe joint (Small pipe)		1	Tapping screw (small) For remote controller holder installation		2

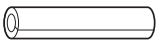
11-6. Ceiling type

■ Models: ABHG30LRTE, ABHG36LRTE, and ABHG45LRTA

Part name	Exterior	Q'ty	Part name	Exterior	Q'ty
Operating manual		1	Cable tie (Large)		4
Installation manual		1	Cable tie (Small)		4
M10 nut A (with flange)		4	Drain hose insulation		1
M10 nut B (with spring lockwasher)		4	VT wire L 280 mm		1
Installation template		1	Remote controller		1
Coupler heat insulation (Large)		2	Remote controller holder		1
Coupler heat insulation (Small)		1	Battery		2
Auxiliary pipe assembly		1	Tapping screw		2

Part 2. OUTDOOR UNIT

SIMULTANEOUS MULTI:

AOHG72LRLA

AOHG90LRLA

1. Specifications

Type			Inverter heat pump			
Model name			AOHG72LRLA		AOHG90LRLA	
Power supply			3N 400 V ~ 50 Hz			
Available voltage range			342—456 V			
Starting current			A		11.5	
Capacity	Cooling	Rated	kW		19.00	
			Btu/h		64,800	
		Min.—Max.		kW		8.40—20.90
	Btu/h		28,600—71,300		35,100—82,500	
	Heating	Rated	kW		22.40	
			Btu/h		76,400	
Min.—Max.		kW		7.20—24.60		
Btu/h		24,500—83,900		29,000—101,300		
Input power	Cooling	Rated	kW		5.99	
	Heating		kW		6.12	
Current	Cooling	Rated	A		11.2	
		Max.	A		15.8	
	Heating	Rated	A		11.5	
		Max.	A		15.8	
Power factor	Cooling	Rated	%		77.2	
	Heating		%		76.8	
Fan	Airflow rate	Cooling	m ³ /h		8,400	
		Heating	m ³ /h		8,400	
	Type × Q'ty		Propeller × 2			
	Motor output		W			111 × 2
Sound pressure level *1	Cooling	dB (A)	dB (A)		55	
	Heating		dB (A)		55	
Sound power level	Cooling	dB (A)	dB (A)		68	
	Heating		dB (A)		70	
Heat exchanger type	Dimensions (H × W × D)		mm		1,386 × 1,293 × 36.38	
	Fin pitch		mm			1.45
	Rows × Stages		mm		2 × 66	
	Pipe type		Copper			
	Fin		Type (Material)			Corrugate (Aluminum)
			Surface treatment			Blue fin
Compressor	Type × Q'ty		Scroll × 1			
	Motor output		W			4,700
Refrigerant	Type		R410A			
	Factory charge		g		5,600	
Refrigerant oil	Type		FVC68D			
	Amount		cm ³		2,300	
Enclosure	Material		Painted galvanized steel			
	Color		Beige			
Dimensions (H × W × D)	Net		mm			1,428 × 1,080 × 480
	Gross		mm			1,557 × 1,174 × 600
Weight	Net		kg		163	
	Gross		kg		181	
Connection pipe	Size	Liquid	mm (in)		Ø 12.70 (Ø 1/2)	
		Gas	mm (in)		Ø 25.40 (Ø 1)	
	Method		Brazing			
	Pre-charge length		m			30
	Max. length		m			100
Max. height difference		m			30	
Operation range	Cooling	°C	°C		-15 to 46	
	Heating		°C		-20 to 24	

NOTES:

- Specifications are based on the following conditions:
 - Cooling: Indoor temperature of 27 °CDB/19 °CWB, and outdoor temperature of 35 °CDB/24 °CWB.
 - Heating: Indoor temperature of 20 °CDB/15 °CWB, and outdoor temperature of 7 °CDB/6 °CWB.
 - Pipe length: 7.5 m, Height difference: 0 m.
- Protective function might work when using it outside the operation range.
- *1: Sound pressure level
 - Measured values in manufacturer's anechoic chamber.
 - Because of the surrounding sound environment, the sound levels measured in actual installation conditions might be higher than the specified values here.

2. Dimensions

2-1. Models: AOHG72LRLA and AOHG90LRLA

Unit: mm

OUTDOOR UNIT
AOHG72-90LRLA

OUTDOOR UNIT
AOHG72-90LRLA

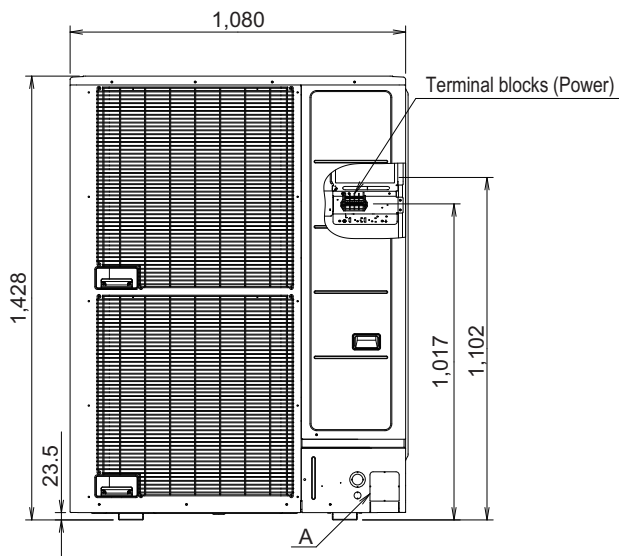
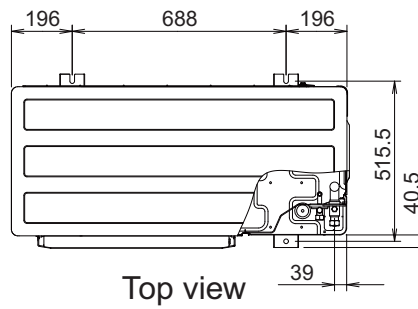

Front view

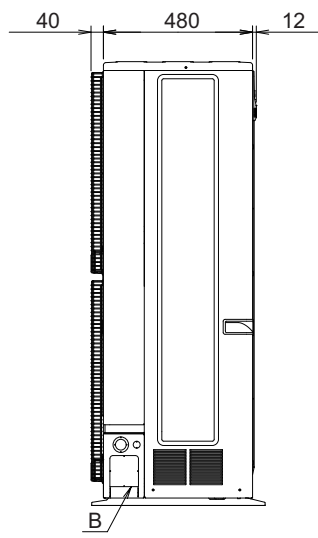

Side view

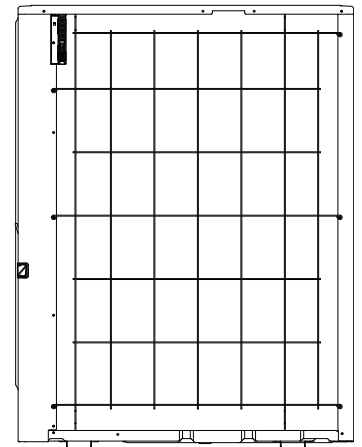

Rear view

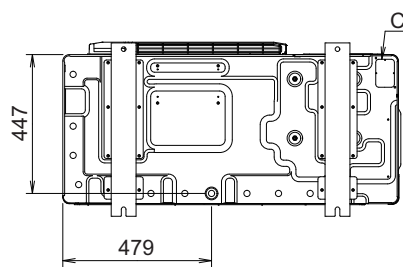

Bottom view

3. Installation space

3-1. Models: AOHG72LRLA and AOHG90LRLA

■ Space requirement

Provide sufficient installation space for product safety.

● Single outdoor unit installation

- When the upper space is open:

Unit: mm

When there are obstacles at the rear only.

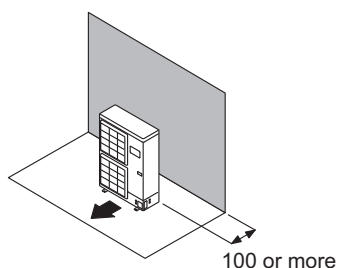

When there are obstacles at the rear and sides.

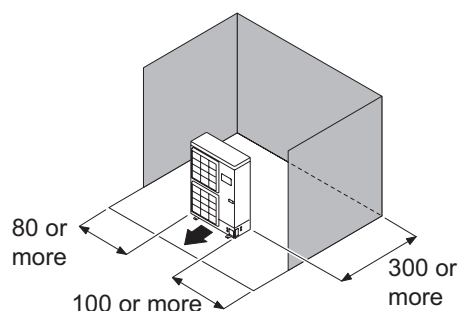

When there are obstacles at the front only.

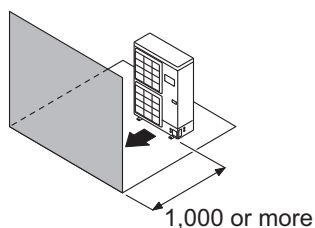

When there are obstacles at the front and rear.

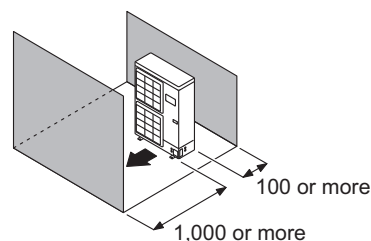

- When there is an obstruction in the upper space:

Unit: mm

When there are obstacles at the rear and above.

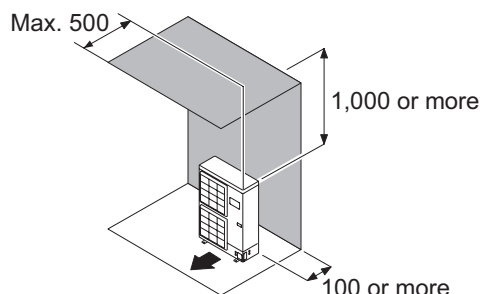

When there are obstacles at the rear, sides, and above.

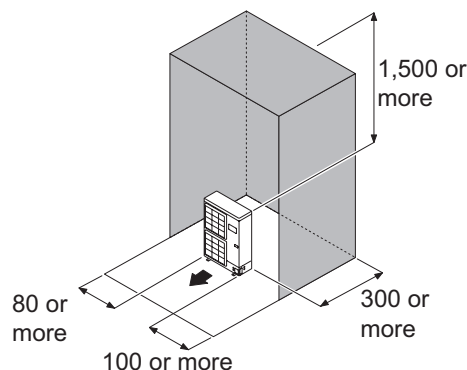

● Multiple outdoor unit installation

NOTES:

- Provide at least 100 mm of space between the outdoor units if multiple units are installed.
- When routing the piping from the side of an outdoor unit, provide space for the piping.
- No more than 3 units must be installed side by side.
When 3 units or more are arranged in a line, provide the space as shown in the following example when an obstruction is present also in the upward area.

- **When the upper space is open:**

When there are obstacles at the rear only.

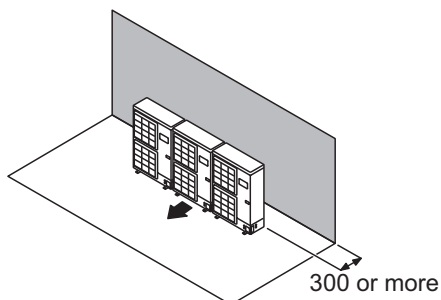

When there are obstacles at the front only.

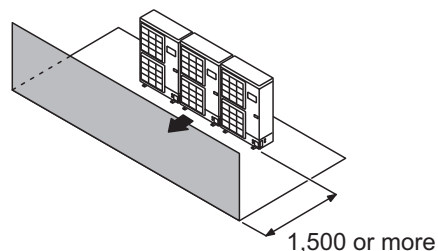

Unit: mm

When there are obstacles at the front and rear.

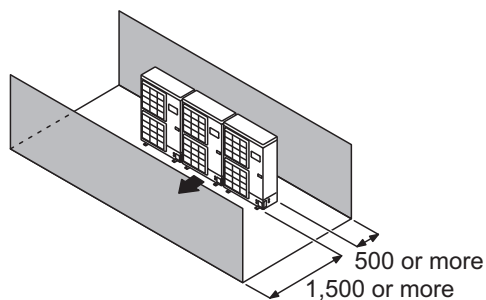

- **When there is an obstruction in the upper space:**

When there are obstacles at the rear and above.

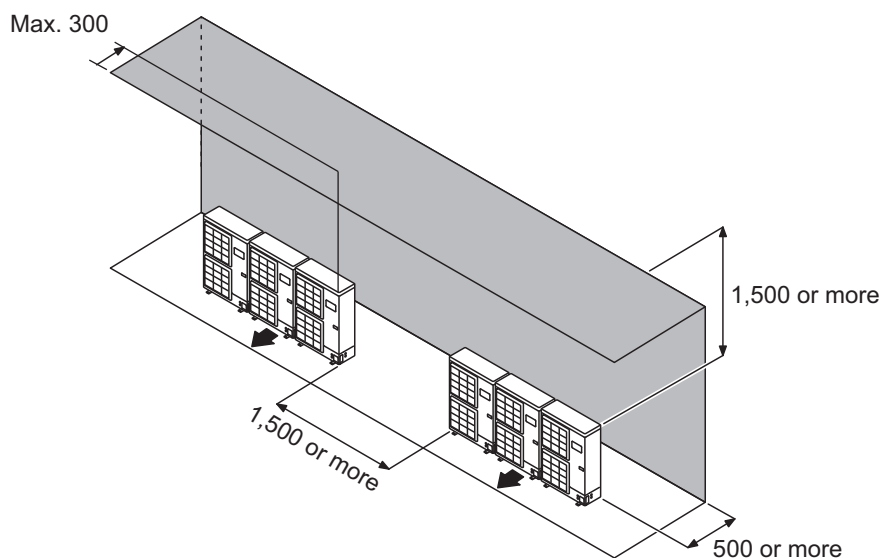

Unit: mm

● Outdoor unit installation in multi-row

Unit: mm

Single parallel unit arrangement

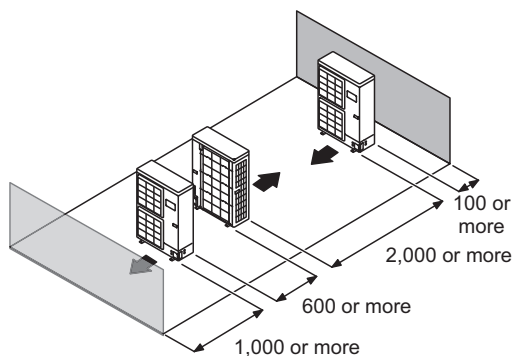

Multiple parallel unit arrangement

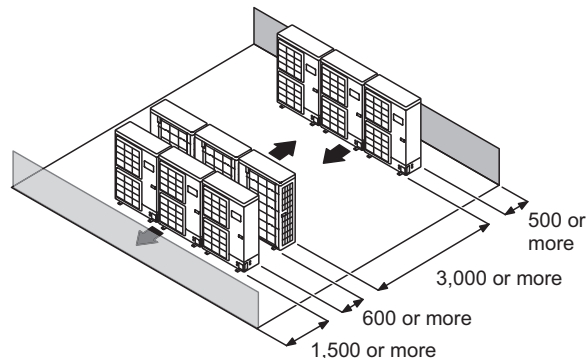

NOTES:

- If the space is larger than stated above, the condition will be the same as when there is no obstacle.
- Height above the floor level should be 50 mm or more.
- When installing the outdoor unit, be sure to open the front and left side to obtain better operation efficiency.

⚠ CAUTION

- When the outdoor temperature is 0 °C or less, do not use the accessory drain pipe and drain cap. If the drain pipe and drain cap are used, the drain water in the pipe may freeze in extremely cold climate. (For reverse cycle model only.)
- In area with heavy snowfall, if the inlet and outlet of the outdoor unit is blocked with snow, it might become difficult to get warm, and it is likely to cause product malfunction. Construct a canopy and a pedestal, or place the unit on a high stand that is locally installed.

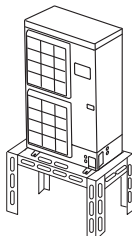

4. Refrigerant circuit

4-1. Models: AOHG72LRLA and AOHG90LRLA

■ Twin type

OUTDOOR UNIT
AOHG72-90LRLA

OUTDOOR UNIT
AOHG72-90LRLA

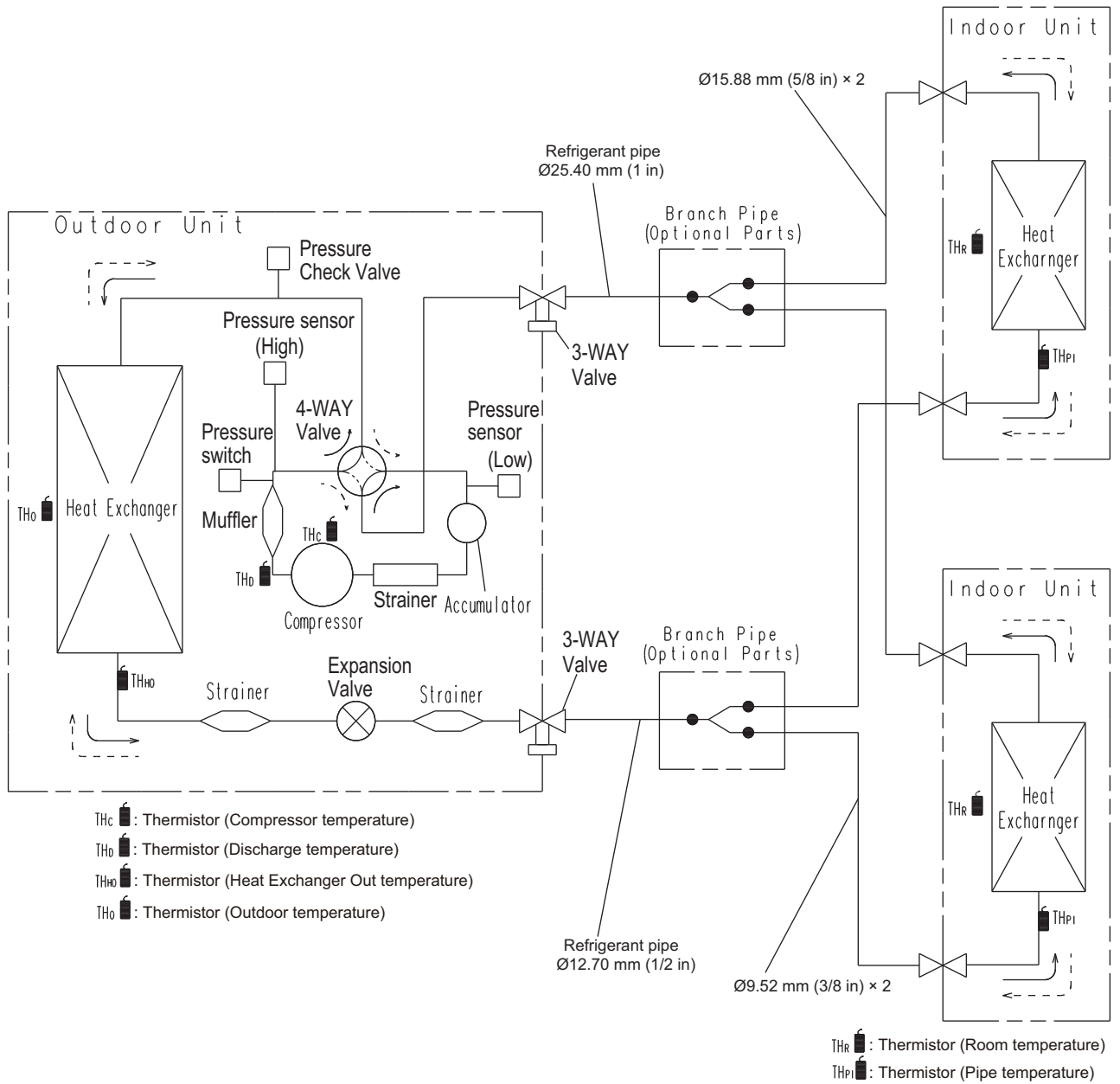

Triple type

OUTDOOR UNIT
AOHG72-90LRLA

OUTDOOR UNIT
AOHG72-90LRLA

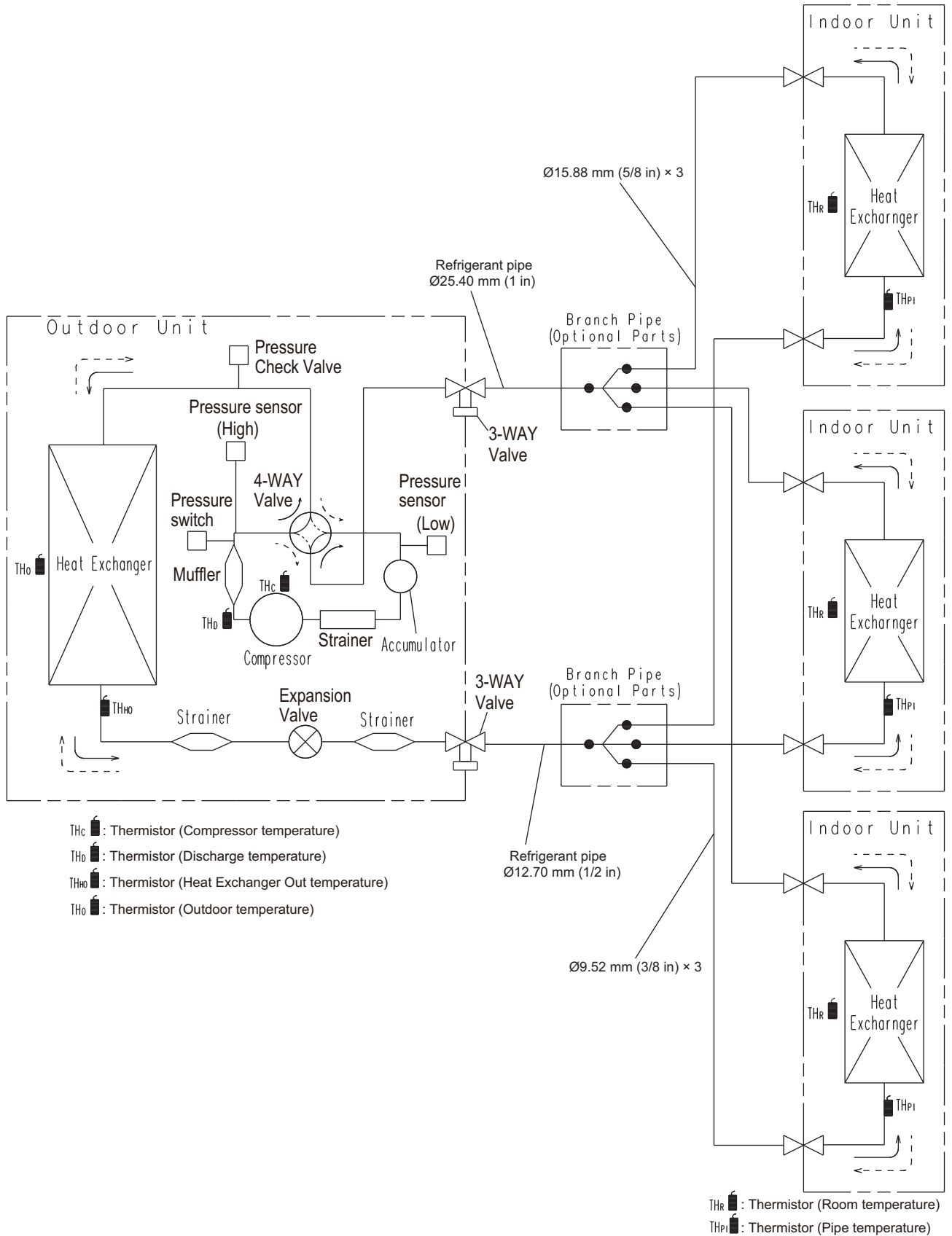

Double twin type

OUTDOOR UNIT
AOHG72-90LRLA

OUTDOOR UNIT
AOHG72-90LRLA

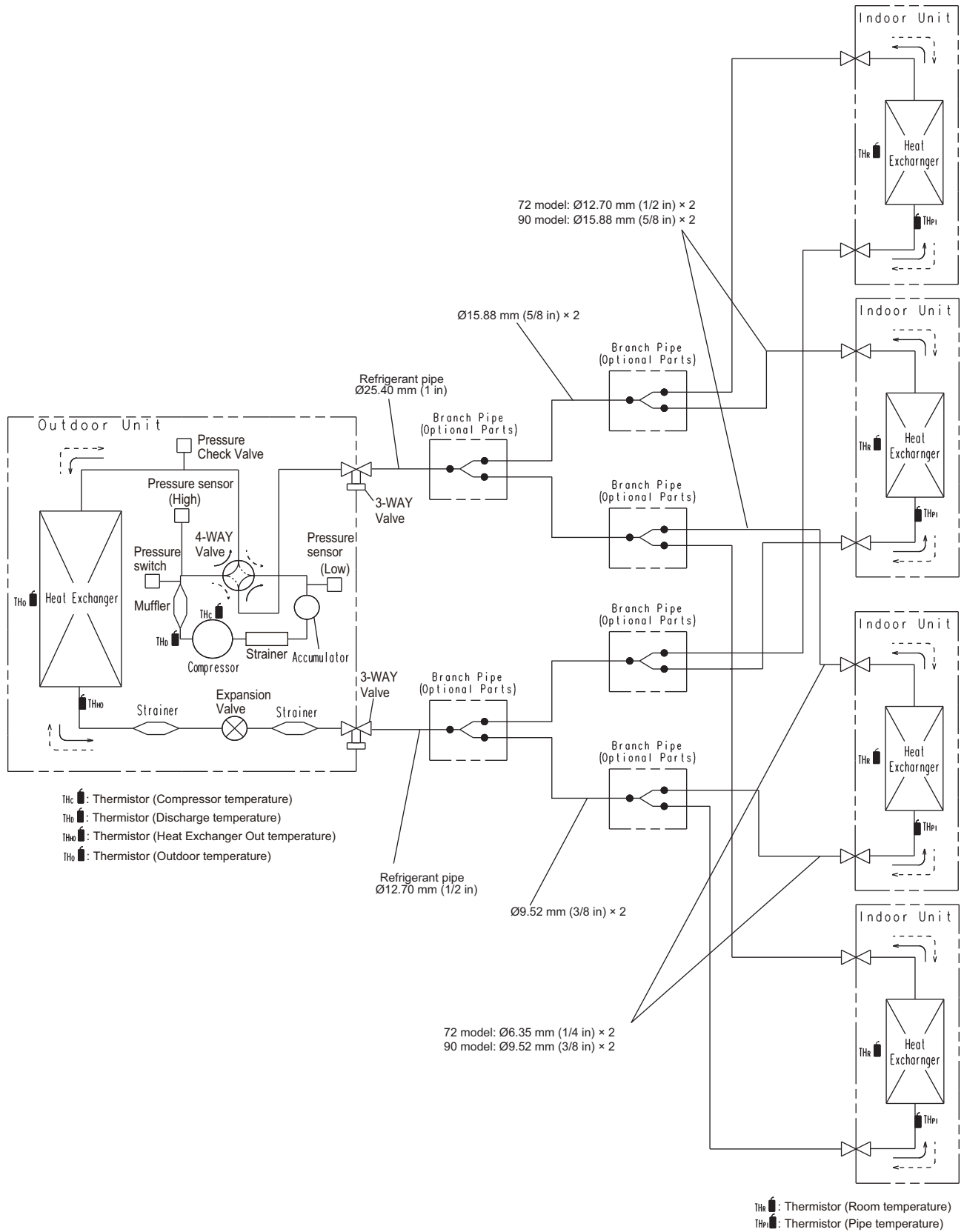

5. Wiring diagrams

5-1. Models: AOHG72LRLA and AOHG90LRLA

OUTDOOR UNIT
AOHG72-90LRLA

OUTDOOR UNIT
AOHG72-90LRLA

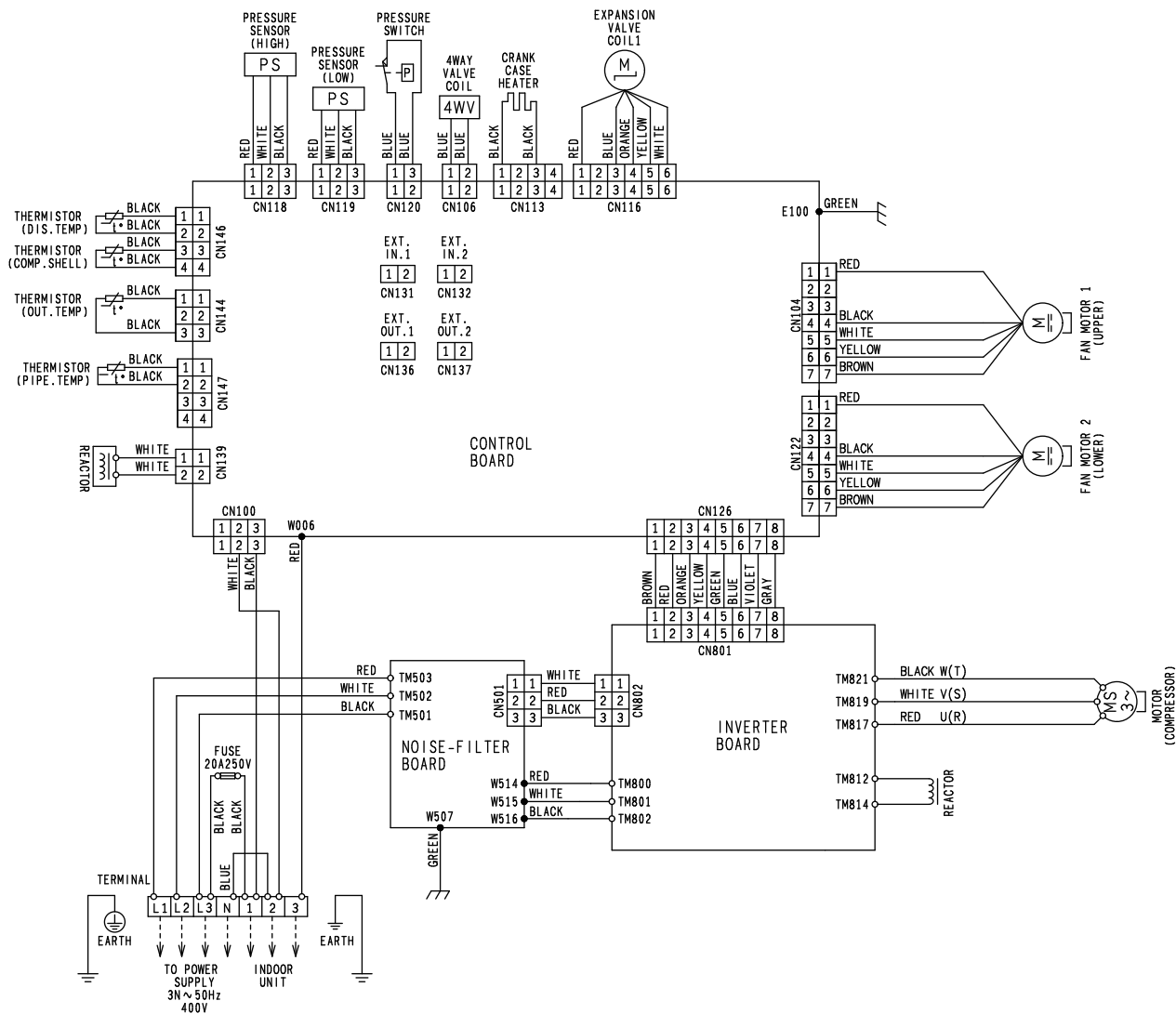

6. Capacity table

6-1. Model: AOHG72LRLA

TC: Total Capacity, SHC: Sensible Heat Capacity, IP: Input Power

■ Cooling capacity (Twin)

● Cassette type

Model: AUHG36LRLE × 2

AFR	m ³ /h	3,600
-----	-------------------	-------

	Indoor temperature																					
	18			21			23			25			27			29			32			
	12			15			16			18			19			21			23			
°CDB	TC	SHC	IP	TC	SHC	IP	TC	SHC	IP	TC	SHC	IP	TC	SHC	IP	TC	SHC	IP	TC	SHC	IP	
Outdoor temperature	°CDB	kW			kW			kW			kW			kW			kW			kW		
	-15	17.44	14.10	2.73	19.42	14.19	2.77	20.08	15.43	2.79	21.40	15.49	2.82	22.07	16.71	2.83	23.39	16.65	2.86	24.72	17.74	2.89
	-10	17.26	13.96	2.74	19.23	14.05	2.78	19.88	15.28	2.79	21.20	15.32	2.82	21.85	16.55	2.83	23.16	16.48	2.86	24.48	17.56	2.89
	0	17.10	13.83	2.91	19.05	13.92	2.95	19.69	15.13	2.97	20.99	15.18	3.00	21.64	16.38	3.02	22.95	16.32	3.05	24.24	17.38	3.08
	5	17.06	13.80	3.04	19.01	13.88	3.09	19.65	15.09	3.11	20.94	15.13	3.14	21.60	16.35	3.16	22.89	16.28	3.18	24.19	17.35	3.21
	10	16.88	13.77	3.42	18.81	13.86	3.47	19.44	15.06	3.49	20.72	15.12	3.52	21.37	16.32	3.54	22.65	16.27	3.58	23.94	17.32	3.62
	15	16.40	13.61	3.53	18.25	13.84	3.59	18.89	15.04	3.61	20.12	15.09	3.64	20.74	16.30	3.66	21.99	16.23	3.70	23.23	17.28	3.74
	20	16.62	13.74	3.93	18.50	13.97	4.00	19.14	15.19	4.01	20.40	15.23	4.05	21.03	16.46	4.08	22.29	16.40	4.12	23.56	17.46	4.15
	25	16.78	13.75	4.67	18.69	13.98	4.74	19.33	15.20	4.76	20.61	15.25	4.81	21.24	16.48	4.83	22.52	16.41	4.88	23.79	17.48	4.93
	30	16.45	13.07	5.33	18.33	13.29	5.40	18.96	14.45	5.43	20.19	14.49	5.49	20.82	15.65	5.51	22.07	15.59	5.56	23.32	16.62	5.63
	35	15.01	12.77	5.94	16.72	13.06	6.02	17.29	14.20	6.06	18.43	14.24	6.12	19.00	15.39	6.15	20.14	15.32	6.21	21.28	16.32	6.27
40	14.86	12.06	5.62	16.55	12.41	5.70	17.12	13.49	5.74	18.25	13.53	5.79	18.81	14.62	5.82	19.94	14.57	5.88	21.07	15.51	5.94	
46	11.84	10.93	5.48	13.19	11.74	5.55	13.63	12.44	5.59	14.52	12.81	5.64	14.98	13.83	5.68	15.89	13.77	5.73	16.78	14.65	5.78	

● Duct type

Model: ARHG36LMLE × 2

AFR	m ³ /h	3,800
-----	-------------------	-------

	Indoor temperature																					
	18			21			23			25			27			29			32			
	12			15			16			18			19			21			23			
°CDB	TC	SHC	IP	TC	SHC	IP	TC	SHC	IP	TC	SHC	IP	TC	SHC	IP	TC	SHC	IP	TC	SHC	IP	
Outdoor temperature	°CDB	kW			kW			kW			kW			kW			kW			kW		
	-15	17.44	13.04	3.06	19.42	13.12	3.11	20.08	14.26	3.13	21.40	14.32	3.16	22.07	15.45	3.17	23.39	15.39	3.21	24.72	16.40	3.24
	-10	17.26	12.91	3.07	19.23	12.99	3.12	19.88	14.12	3.13	21.20	14.16	3.16	21.85	15.30	3.18	23.16	15.24	3.21	24.48	16.23	3.24
	0	17.10	12.79	3.27	19.05	12.87	3.31	19.69	13.98	3.33	20.99	14.03	3.36	21.64	15.15	3.38	22.95	15.09	3.42	24.24	16.07	3.45
	5	17.06	12.76	3.41	19.01	12.83	3.46	19.65	13.95	3.48	20.94	13.99	3.51	21.60	15.11	3.54	22.89	15.05	3.57	24.19	16.03	3.60
	10	16.88	12.73	3.83	18.81	12.81	3.89	19.44	13.93	3.91	20.72	13.98	3.95	21.37	15.09	3.97	22.65	15.04	4.01	23.94	16.01	4.06
	15	16.40	12.58	3.96	18.25	12.80	4.02	18.89	13.91	4.05	20.12	13.95	4.08	20.74	15.07	4.11	21.99	15.01	4.14	23.23	15.98	4.19
	20	16.62	12.71	4.41	18.50	12.92	4.48	19.14	14.04	4.49	20.40	14.08	4.54	21.03	15.22	4.57	22.29	15.16	4.62	23.56	16.14	4.65
	25	16.78	12.71	5.23	18.69	12.93	5.31	19.33	14.05	5.34	20.61	14.09	5.39	21.24	15.23	5.42	22.52	15.17	5.47	23.79	16.16	5.52
	30	16.45	12.08	5.97	18.33	12.28	6.05	18.96	13.36	6.08	20.19	13.40	6.15	20.82	14.47	6.18	22.07	14.41	6.23	23.32	15.36	6.30
	35	15.01	11.81	6.65	16.72	12.07	6.75	17.29	13.13	6.79	18.43	13.17	6.86	19.00	14.22	6.89	20.14	14.16	6.96	21.28	15.09	7.03
40	14.86	11.15	6.30	16.55	11.47	6.39	17.12	12.47	6.44	18.25	12.51	6.49	18.81	13.51	6.52	19.94	13.46	6.59	21.07	14.34	6.66	
46	11.84	10.10	6.14	13.19	10.85	6.22	13.63	11.50	6.26	14.52	11.84	6.32	14.98	12.78	6.36	15.89	12.73	6.42	16.78	13.55	6.48	

● Ceiling type

Model: ABHG36LRTE × 2

AFR	m ³ /h	3,800
-----	-------------------	-------

	Indoor temperature																					
	18			21			23			25			27			29			32			
	12			15			16			18			19			21			23			
°CDB	TC	SHC	IP	TC	SHC	IP	TC	SHC	IP	TC	SHC	IP	TC	SHC	IP	TC	SHC	IP	TC	SHC	IP	
Outdoor temperature	°CDB	kW			kW			kW			kW			kW			kW			kW		
	-15	17.44	14.10	2.73	19.42	14.19	2.77	20.08	15.43	2.79	21.40	15.49	2.82	22.07	16.71	2.83	23.39	16.65	2.86	24.72	17.74	2.89
	-10	17.26	13.96	2.74	19.23	14.05	2.78	19.88	15.28	2.79	21.20	15.32	2.82	21.85	16.55	2.83	23.16	16.48	2.86	24.48	17.56	2.89
	0	17.10	13.83	2.91	19.05	13.92	2.95	19.69	15.13	2.97	20.99	15.18	3.00	21.64	16.38	3.02	22.95	16.32	3.05	24.24	17.38	3.08
	5	17.06	13.80	3.04	19.01	13.88	3.09	19.65	15.09	3.11	20.94	15.13	3.14	21.60	16.35	3.16	22.89	16.28	3.18	24.19	17.35	3.21
	10	16.88	13.77	3.42	18.81	13.86	3.47	19.44	15.06	3.49	20.72	15.12	3.52	21.37	16.32	3.54	22.65	16.27	3.58	23.94	17.32	3.62
	15	16.40	13.61	3.53	18.25	13.84	3.59	18.89	15.04	3.61	20.12	15.09	3.64	20.74	16.30	3.66	21.99	16.23	3.70	23.23	17.28	3.74
	20	16.62	13.74	3.93	18.50	13.97	4.00	19.14	15.19	4.01	20.40	15.23	4.05	21.03	16.46	4.08	22.29	16.40	4.12	23.56	17.46	4.15
	25	16.78	13.75	4.67	18.69	13.98	4.74	19.33	15.20	4.76	20.61	15.25	4.81	21.24	16.48	4.83	22.52	16.41	4.88	23.79	17.48	4.93
	30	16.45	13.07	5.33	18.33	13.29	5.40	18.96	14.45	5.43	20.19	14.49	5.49	20.82	15.65	5.51	22.07	15.59	5.56	23.32	16.62	5.63
	35	15.01	12.77	5.94	16.72	13.06	6.02	17.29	14.20	6.06	18.43	14.24	6.12	19.00	15.39	6.15	20.14	15.32	6.21	21.28	16.32	6.27
40	14.86	12.06	5.62	16.55	12.41	5.70	17.12	13.49	5.74	18.25	13.53	5.79	18.81	14.62	5.82	19.94	14.57	5.88	21.07	15.51	5.94	
46	11.84	10.93	5.48	13.19	11.74	5.55	13.63	12.44	5.59	14.52	12.81	5.64	14.98	13.83	5.68	15.89	13.77	5.73	16.78	14.65	5.78	

■ Heating capacity (Twin)

● Cassette type

Model: AUHG36LRLE × 2

AFR	m ³ /h	3,600
-----	-------------------	-------

		Indoor temperature											
		°CDB		16		18		20		22		24	
		°CDB	°CWB	TC	IP	TC	IP	TC	IP	TC	IP	TC	IP
Outdoor temperature			kW		kW		kW		kW		kW		
	-20	-21	10.58	5.91	10.32	6.03	10.07	6.16	9.82	6.28	9.57	6.39	
	-15	-16	16.21	6.82	15.83	6.96	15.44	7.11	15.06	7.25	14.68	7.39	
	-10	-11	18.89	7.25	18.44	7.40	18.00	7.55	17.55	7.70	17.10	7.85	
	-5	-7	20.98	7.56	20.48	7.71	19.98	7.87	19.48	8.03	18.99	8.18	
	0	-2	22.62	7.63	22.08	7.79	21.54	7.95	21.00	8.11	20.47	8.27	
	5	3	25.56	7.65	24.95	7.81	24.35	7.97	23.73	8.11	23.13	8.27	
	7	6	25.83	7.66	25.22	7.82	24.60	7.98	23.99	8.14	23.37	8.30	
	10	8	27.04	7.61	26.39	7.76	25.74	7.93	25.09	8.08	24.46	8.25	
	15	10	28.06	7.60	27.39	7.75	26.72	7.92	26.05	8.08	25.38	8.20	
	20	15	25.25	6.64	24.64	6.76	24.04	6.91	23.44	7.05	22.83	7.14	
24	18	25.81	6.60	25.19	6.73	24.58	6.87	23.96	7.02	23.35	7.11		

● Duct type

Model: ARHG36LMLE × 2

AFR	m ³ /h	4,200
-----	-------------------	-------

		Indoor temperature											
		°CDB		16		18		20		22		24	
		°CDB	°CWB	TC	IP	TC	IP	TC	IP	TC	IP	TC	IP
Outdoor temperature			kW		kW		kW		kW		kW		
	-20	-21	10.58	5.89	10.32	6.01	10.07	6.14	9.82	6.26	9.57	6.37	
	-15	-16	16.21	6.80	15.83	6.94	15.44	7.08	15.06	7.22	14.68	7.36	
	-10	-11	18.89	7.22	18.44	7.37	18.00	7.52	17.55	7.67	17.10	7.82	
	-5	-7	20.98	7.53	20.48	7.69	19.98	7.84	19.48	8.00	18.99	8.15	
	0	-2	22.62	7.61	22.08	7.77	21.54	7.92	21.00	8.08	20.47	8.24	
	5	3	25.56	7.63	24.95	7.79	24.35	7.94	23.73	8.09	23.13	8.25	
	7	6	25.83	7.63	25.22	7.79	24.60	7.95	23.99	8.11	23.37	8.27	
	10	8	27.04	7.58	26.39	7.73	25.74	7.90	25.09	8.05	24.46	8.22	
	15	10	28.06	7.58	27.39	7.73	26.72	7.89	26.05	8.06	25.38	8.17	
	20	15	25.25	6.61	24.64	6.74	24.04	6.88	23.44	7.03	22.83	7.12	
24	18	25.81	6.58	25.19	6.71	24.58	6.85	23.96	6.99	23.35	7.08		

● Ceiling type

Model: ABHG36LRTE × 2

AFR	m ³ /h	3,800
-----	-------------------	-------

		Indoor temperature											
		°CDB		16		18		20		22		24	
		°CDB	°CWB	TC	IP	TC	IP	TC	IP	TC	IP	TC	TC
Outdoor temperature			kW		kW		kW		kW		kW		
	-20	-21	10.58	5.91	10.32	6.03	10.07	6.16	9.82	6.28	9.57	6.39	
	-15	-16	16.21	6.82	15.83	6.96	15.44	7.11	15.06	7.25	14.68	7.39	
	-10	-11	18.89	7.25	18.44	7.40	18.00	7.55	17.55	7.70	17.10	7.85	
	-5	-7	20.98	7.56	20.48	7.71	19.98	7.87	19.48	8.03	18.99	8.18	
	0	-2	22.62	7.63	22.08	7.79	21.54	7.95	21.00	8.11	20.47	8.27	
	5	3	25.56	7.65	24.95	7.81	24.35	7.97	23.73	8.11	23.13	8.27	
	7	6	25.83	7.66	25.22	7.82	24.60	7.98	23.99	8.14	23.37	8.30	
	10	8	27.04	7.61	26.39	7.76	25.74	7.93	25.09	8.08	24.46	8.25	
	15	10	28.06	7.60	27.39	7.75	26.72	7.92	26.05	8.08	25.38	8.20	
	20	15	25.25	6.64	24.64	6.76	24.04	6.91	23.44	7.05	22.83	7.14	
24	18	25.81	6.60	25.19	6.73	24.58	6.87	23.96	7.02	23.35	7.11		

■ Cooling capacity (Triple)

● Compact cassette type

Model: AUHG24LVLA × 3

AFR	m ³ /h											2,790							
-----	-------------------	--	--	--	--	--	--	--	--	--	--	-------	--	--	--	--	--	--	--

Outdoor temperature	Indoor temperature																				
	18			21			23			25			27			29			32		
	12			15			16			18			19			21			23		
	°CDB	SHC	IP	TC	SHC	IP	TC	SHC	IP	TC	SHC	IP	TC	SHC	IP	TC	SHC	IP	TC	SHC	IP
	kW			kW			kW			kW			kW			kW			kW		
-15	17.44	12.40	2.94	19.42	12.48	2.99	20.08	13.57	3.01	21.40	13.61	3.04	22.07	14.69	3.05	23.39	14.63	3.09	24.72	15.60	3.11
-10	17.26	12.28	2.95	19.23	12.35	3.00	19.88	13.43	3.01	21.20	13.47	3.04	21.85	14.55	3.06	23.16	14.49	3.09	24.48	15.43	3.11
0	17.10	12.16	3.14	19.05	12.24	3.18	19.69	13.30	3.20	20.99	13.35	3.24	21.64	14.40	3.26	22.95	14.35	3.29	24.24	15.28	3.32
5	17.06	12.13	3.28	19.01	12.20	3.33	19.65	13.27	3.35	20.94	13.30	3.38	21.60	14.37	3.40	22.89	14.32	3.43	24.19	15.25	3.47
10	16.88	12.11	3.68	18.81	12.19	3.74	19.44	13.24	3.76	20.72	13.29	3.80	21.37	14.35	3.82	22.65	14.30	3.86	23.94	15.22	3.90
15	16.40	11.97	3.81	18.25	12.17	3.87	18.89	13.22	3.89	20.12	13.26	3.93	20.74	14.33	3.95	21.99	14.27	3.99	23.23	15.20	4.03
20	16.62	12.08	4.24	18.50	12.29	4.31	19.14	13.35	4.32	20.40	13.39	4.37	21.03	14.47	4.39	22.29	14.41	4.44	23.56	15.35	4.48
25	16.78	12.09	5.03	18.69	12.29	5.11	19.33	13.36	5.13	20.61	13.40	5.19	21.24	14.49	5.21	22.52	14.43	5.26	23.79	15.37	5.31
30	16.45	11.49	5.74	18.33	11.68	5.82	18.96	12.70	5.85	20.19	12.74	5.92	20.82	13.76	5.94	22.07	13.71	6.00	23.32	14.61	6.07
35	15.01	11.23	6.40	16.72	11.48	6.50	17.29	12.49	6.54	18.43	12.52	6.60	19.00	13.53	6.63	20.14	13.47	6.70	21.28	14.35	6.77
40	14.86	10.60	6.06	16.55	10.91	6.14	17.12	11.86	6.19	18.25	11.90	6.24	18.81	12.85	6.27	19.94	12.81	6.34	21.07	13.63	6.41
46	11.84	9.61	5.91	13.19	10.32	5.99	13.63	10.94	6.02	14.52	11.26	6.08	14.98	12.16	6.12	15.89	12.10	6.18	16.78	12.88	6.24

● Duct type

Model: ARHG24LMLA × 3

AFR	m ³ /h											3,300							
-----	-------------------	--	--	--	--	--	--	--	--	--	--	-------	--	--	--	--	--	--	--

Outdoor temperature	Indoor temperature																				
	18			21			23			25			27			29			32		
	12			15			16			18			19			21			23		
	°CDB	SHC	IP	TC	SHC	IP	TC	SHC	IP	TC	SHC	IP	TC	SHC	IP	TC	SHC	IP	TC	SHC	IP
	kW			kW			kW			kW			kW			kW			kW		
-15	17.44	12.65	2.87	19.42	12.73	2.92	20.08	13.84	2.93	21.40	13.89	2.96	22.07	14.99	2.97	23.39	14.93	3.01	24.72	15.91	3.04
-10	17.26	12.53	2.88	19.23	12.60	2.92	19.88	13.70	2.93	21.20	13.74	2.96	21.85	14.84	2.98	23.16	14.79	3.01	24.48	15.75	3.04
0	17.10	12.41	3.07	19.05	12.49	3.11	19.69	13.57	3.13	20.99	13.62	3.16	21.64	14.70	3.18	22.95	14.64	3.21	24.24	15.59	3.24
5	17.06	12.38	3.20	19.01	12.45	3.25	19.65	13.54	3.27	20.94	13.57	3.30	21.60	14.66	3.32	22.89	14.61	3.35	24.19	15.56	3.38
10	16.88	12.36	3.59	18.81	12.43	3.65	19.44	13.51	3.67	20.72	13.56	3.71	21.37	14.64	3.73	22.65	14.59	3.76	23.94	15.53	3.81
15	16.40	12.21	3.72	18.25	12.42	3.77	18.89	13.49	3.80	20.12	13.53	3.83	20.74	14.62	3.85	21.99	14.56	3.89	23.23	15.50	3.93
20	16.62	12.33	4.14	18.50	12.53	4.21	19.14	13.63	4.22	20.40	13.67	4.26	21.03	14.77	4.29	22.29	14.71	4.33	23.56	15.66	4.37
25	16.78	12.33	4.91	18.69	12.54	4.98	19.33	13.64	5.01	20.61	13.68	5.06	21.24	14.78	5.08	22.52	14.72	5.13	23.79	15.68	5.18
30	16.45	11.72	5.60	18.33	11.92	5.68	18.96	12.96	5.71	20.19	13.00	5.77	20.82	14.04	5.80	22.07	13.98	5.85	23.32	14.91	5.92
35	15.01	11.45	6.25	16.72	11.72	6.34	17.29	12.74	6.38	18.43	12.78	6.44	19.00	13.80	6.47	20.14	13.74	6.53	21.28	14.64	6.60
40	14.86	10.82	5.91	16.55	11.13	5.99	17.12	12.10	6.04	18.25	12.14	6.09	18.81	13.11	6.12	19.94	13.06	6.18	21.07	13.91	6.25
46	11.84	9.80	5.76	13.19	10.53	5.84	13.63	11.16	5.88	14.52	11.49	5.93	14.98	12.40	5.97	15.89	12.35	6.03	16.78	13.14	6.08

● Floor/Ceiling type

Model: ABHG24LVTA × 3

AFR	m ³ /h											2,940							
-----	-------------------	--	--	--	--	--	--	--	--	--	--	-------	--	--	--	--	--	--	--

Outdoor temperature	Indoor temperature																				
	18			21			23			25			27			29			32		
	12			15			16			18			19			21			23		
	°CDB	SHC	IP	TC	SHC	IP	TC	SHC	IP	TC	SHC	IP	TC	SHC	IP	TC	SHC	IP	TC	SHC	IP
	kW			kW			kW			kW			kW			kW			kW		
-15	17.44	12.40	2.94	19.42	12.48	2.99	20.08	13.57	3.01	21.40	13.61	3.04	22.07	14.69	3.05	23.39	14.63	3.09	24.72	15.60	3.11
-10	17.26	12.28	2.95	19.23	12.35	3.00	19.88	13.43	3.01	21.20	13.47	3.04	21.85	14.55	3.06	23.16	14.49	3.09	24.48	15.43	3.11
0	17.10	12.16	3.14	19.05	12.24	3.18	19.69	13.30	3.20	20.99	13.35	3.24	21.64	14.40	3.26	22.95	14.35	3.29	24.24	15.28	3.32
5	17.06	12.13	3.28	19.01	12.20	3.33	19.65	13.27	3.35	20.94	13.30	3.38	21.60	14.37	3.40	22.89	14.32	3.43	24.19	15.25	3.47
10	16.88	12.11	3.68	18.81	12.19	3.74	19.44	13.24	3.76	20.72	13.29	3.80	21.37	14.35	3.82	22.65	14.30	3.86	23.94	15.22	3.90
15	16.40	11.97	3.81	18.25	12.17	3.87	18.89	13.22	3.89	20.12	13.26	3.93	20.74	14.33	3.95	21.99	14.27	3.99	23.23	15.20	4.03
20	16.62	12.08	4.24	18.50	12.29	4.31	19.14	13.35	4.32	20.40	13.39	4.37	21.03	14.47	4.39	22.29	14.41	4.44	23.56	15.35	4.48
25	16.78	12.09	5.03	18.69	12.29	5.11	19.33	13.36	5.13	20.61	13.40	5.19	21.24	14.49	5.21	22.52	14.43	5.26	23.79	15.37	5.31
30	16.45	11.49	5.74	18.33	11.68	5.82	18.96	12.70	5.85	20.19	12.74	5.92	20.82	13.76	5.94	22.07	13.71	6.00	23.32	14.61	6.07
35	15.01	11.23	6.40	16.72	11.48	6.50	17.29	12.49	6.54	18.43	12.52	6.60	19.00	13.53	6.63	20.14	13.47	6.70	21.28	14.35	6.77
40	14.86	10.60	6.06	16.55	10.91	6.14	17.12	11.86	6.19	18.25	11.90	6.24	18.81	12.85	6.27	19.94	12.81	6.34	21.07	13.63	6.41
46	11.84	9.61	5.91	13.19	10.32	5.99	13.63	10.94	6.02	14.52	11.26	6.08	14.98	12.16	6.12	15.89	12.10	6.18	16.78	12.88	6.24

■ Heating capacity (Triple)

● Compact cassette type

Model: AUHG24LVLA × 3

AFR	m ³ /h	2,790
-----	-------------------	-------

		Indoor temperature											
		°CDB		16		18		20		22		24	
		°CDB	°CWB	TC	IP	TC	IP	TC	IP	TC	IP	TC	IP
Outdoor temperature	-20	-21	10.58	5.85	10.32	5.97	10.07	6.09	9.82	6.21	9.57	6.32	
	-15	-16	16.21	6.75	15.83	6.89	15.44	7.03	15.06	7.17	14.68	7.31	
	-10	-11	18.89	7.17	18.44	7.32	18.00	7.47	17.55	7.62	17.10	7.77	
	-5	-7	20.98	7.48	20.48	7.63	19.98	7.79	19.48	7.94	18.99	8.10	
	0	-2	22.62	7.55	22.08	7.71	21.54	7.87	21.00	8.02	20.47	8.18	
	5	3	25.56	7.57	24.95	7.73	24.35	7.89	23.73	8.03	23.13	8.19	
	7	6	25.83	7.58	25.22	7.74	24.60	7.89	23.99	8.05	23.37	8.21	
	10	8	27.04	7.53	26.39	7.68	25.74	7.84	25.09	7.99	24.46	8.16	
	15	10	28.06	7.52	27.39	7.67	26.72	7.83	26.05	8.00	25.38	8.11	
	20	15	25.25	6.57	24.64	6.69	24.04	6.83	23.44	6.98	22.83	7.07	
24	18	25.81	6.53	25.19	6.66	24.58	6.80	23.96	6.94	23.35	7.03		

● Duct type

Model: ARHG24LMLA × 3

AFR	m ³ /h	3,300
-----	-------------------	-------

		Indoor temperature											
		°CDB		16		18		20		22		24	
		°CDB	°CWB	TC	IP	TC	IP	TC	IP	TC	IP	TC	IP
Outdoor temperature	-20	-21	10.58	5.73	10.32	5.85	10.07	5.97	9.82	6.09	9.57	6.20	
	-15	-16	16.21	6.62	15.83	6.75	15.44	6.89	15.06	7.03	14.68	7.17	
	-10	-11	18.89	7.03	18.44	7.17	18.00	7.32	17.55	7.47	17.10	7.61	
	-5	-7	20.98	7.33	20.48	7.48	19.98	7.63	19.48	7.78	18.99	7.94	
	0	-2	22.62	7.40	22.08	7.56	21.54	7.71	21.00	7.87	20.47	8.02	
	5	3	25.56	7.42	24.95	7.58	24.35	7.73	23.73	7.87	23.13	8.02	
	7	6	25.83	7.43	25.22	7.58	24.60	7.74	23.99	7.89	23.37	8.05	
	10	8	27.04	7.38	26.39	7.52	25.74	7.69	25.09	7.83	24.46	8.00	
	15	10	28.06	7.37	27.39	7.52	26.72	7.68	26.05	7.84	25.38	7.95	
	20	15	25.25	6.43	24.64	6.56	24.04	6.70	23.44	6.84	22.83	6.93	
24	18	25.81	6.40	25.19	6.52	24.58	6.67	23.96	6.81	23.35	6.89		

● Floor/Ceiling type

Model: ABHG24LVTA × 3

AFR	m ³ /h	2,940
-----	-------------------	-------

		Indoor temperature											
		°CDB		16		18		20		22		24	
		°CDB	°CWB	TC	IP	TC	IP	TC	IP	TC	IP	TC	IP
Outdoor temperature	-20	-21	10.58	5.85	10.32	5.97	10.07	6.09	9.82	6.21	9.57	6.32	
	-15	-16	16.21	6.75	15.83	6.89	15.44	7.03	15.06	7.17	14.68	7.31	
	-10	-11	18.89	7.17	18.44	7.32	18.00	7.47	17.55	7.62	17.10	7.77	
	-5	-7	20.98	7.48	20.48	7.63	19.98	7.79	19.48	7.94	18.99	8.10	
	0	-2	22.62	7.55	22.08	7.71	21.54	7.87	21.00	8.02	20.47	8.18	
	5	3	25.56	7.57	24.95	7.73	24.35	7.89	23.73	8.03	23.13	8.19	
	7	6	25.83	7.58	25.22	7.74	24.60	7.89	23.99	8.05	23.37	8.21	
	10	8	27.04	7.53	26.39	7.68	25.74	7.84	25.09	7.99	24.46	8.16	
	15	10	28.06	7.52	27.39	7.67	26.72	7.83	26.05	8.00	25.38	8.11	
	20	15	25.25	6.57	24.64	6.69	24.04	6.83	23.44	6.98	22.83	7.07	
24	18	25.81	6.53	25.19	6.66	24.58	6.80	23.96	6.94	23.35	7.03		

■ Cooling capacity (Double twin)

● Compact cassette type

Model: AUHG18LVLB × 4

AFR	m ³ /h	2,720
-----	-------------------	-------

Outdoor temperature	Indoor temperature																				
	18			21			23			25			27			29			32		
	°CDB			°CWB			°CDB			°CDB			°CDB			°CDB			°CDB		
	TC	SHC	IP	TC	SHC	IP	TC	SHC	IP	TC	SHC	IP	TC	SHC	IP	TC	SHC	IP	TC	SHC	IP
-15	17.44	13.28	2.78	19.42	13.37	2.82	20.08	14.53	2.84	21.40	14.58	2.87	22.07	15.74	2.88	23.39	15.68	2.92	24.72	16.71	2.94
-10	17.26	13.15	2.79	19.23	13.23	2.83	19.88	14.39	2.84	21.20	14.43	2.87	21.85	15.58	2.89	23.16	15.52	2.92	24.48	16.53	2.94
0	17.10	13.03	2.97	19.05	13.11	3.01	19.69	14.24	3.03	20.99	14.29	3.06	21.64	15.43	3.08	22.95	15.37	3.11	24.24	16.37	3.14
5	17.06	13.00	3.10	19.01	13.07	3.15	19.65	14.21	3.17	20.94	14.25	3.20	21.60	15.40	3.21	22.89	15.33	3.24	24.19	16.33	3.27
10	16.88	12.97	3.48	18.81	13.05	3.54	19.44	14.19	3.56	20.72	14.24	3.59	21.37	15.37	3.61	22.65	15.32	3.64	23.94	16.31	3.69
15	16.40	12.82	3.60	18.25	13.03	3.66	18.89	14.17	3.68	20.12	14.21	3.71	20.74	15.35	3.73	21.99	15.29	3.77	23.23	16.28	3.81
20	16.62	12.94	4.01	18.50	13.16	4.07	19.14	14.31	4.09	20.40	14.35	4.13	21.03	15.50	4.15	22.29	15.44	4.20	23.56	16.44	4.23
25	16.78	12.95	4.75	18.69	13.17	4.83	19.33	14.32	4.85	20.61	14.36	4.90	21.24	15.52	4.92	22.52	15.45	4.97	23.79	16.46	5.02
30	16.45	12.31	5.43	18.33	12.51	5.50	18.96	13.61	5.53	20.19	13.65	5.59	20.82	14.74	5.62	22.07	14.68	5.67	23.32	15.65	5.73
35	15.01	12.03	6.05	16.72	12.30	6.14	17.29	13.37	6.18	18.43	13.41	6.24	19.00	14.49	6.27	20.14	14.43	6.33	21.28	15.37	6.39
40	14.86	11.36	5.73	16.55	11.69	5.81	17.12	12.71	5.85	18.25	12.74	5.90	18.81	13.77	5.93	19.94	13.72	5.99	21.07	14.60	6.05
46	11.84	10.29	5.58	13.19	11.05	5.66	13.63	11.71	5.69	14.52	12.06	5.75	14.98	13.02	5.78	15.89	12.97	5.84	16.78	13.80	5.89

● Slim duct type

Model: ARHG18LLTB × 4

AFR	m ³ /h	3,760
-----	-------------------	-------

Outdoor temperature	Indoor temperature																				
	18			21			23			25			27			29			32		
	°CDB			°CWB			°CDB			°CDB			°CDB			°CDB			°CDB		
	TC	SHC	IP	TC	SHC	IP	TC	SHC	IP	TC	SHC	IP	TC	SHC	IP	TC	SHC	IP	TC	SHC	IP
-15	17.44	12.91	2.91	19.42	13.00	2.96	20.08	14.13	2.98	21.40	14.18	3.01	22.07	15.30	3.02	23.39	15.24	3.06	24.72	16.24	3.08
-10	17.26	12.79	2.92	19.23	12.87	2.97	19.88	13.99	2.98	21.20	14.03	3.01	21.85	15.15	3.03	23.16	15.09	3.06	24.48	16.08	3.08
0	17.10	12.67	3.11	19.05	12.75	3.15	19.69	13.85	3.17	20.99	13.90	3.20	21.64	15.00	3.22	22.95	14.94	3.26	24.24	15.92	3.29
5	17.06	12.64	3.24	19.01	12.71	3.30	19.65	13.82	3.32	20.94	13.86	3.35	21.60	14.97	3.37	22.89	14.91	3.40	24.19	15.88	3.43
10	16.88	12.61	3.65	18.81	12.69	3.71	19.44	13.79	3.73	20.72	13.84	3.76	21.37	14.94	3.79	22.65	14.90	3.82	23.94	15.86	3.87
15	16.40	12.47	3.77	18.25	12.67	3.83	18.89	13.77	3.86	20.12	13.81	3.89	20.74	14.93	3.91	21.99	14.87	3.95	23.23	15.83	3.99
20	16.62	12.59	4.20	18.50	12.80	4.27	19.14	13.91	4.28	20.40	13.95	4.33	21.03	15.07	4.35	22.29	15.01	4.40	23.56	15.99	4.43
25	16.78	12.59	4.98	18.69	12.80	5.06	19.33	13.92	5.08	20.61	13.96	5.14	21.24	15.09	5.16	22.52	15.03	5.21	23.79	16.00	5.26
30	16.45	11.97	5.69	18.33	12.17	5.77	18.96	13.23	5.79	20.19	13.27	5.86	20.82	14.33	5.89	22.07	14.28	5.94	23.32	15.22	6.01
35	15.01	11.69	6.34	16.72	11.96	6.43	17.29	13.00	6.47	18.43	13.04	6.54	19.00	14.09	6.57	20.14	14.03	6.63	21.28	14.95	6.70
40	14.86	11.04	6.00	16.55	11.36	6.09	17.12	12.36	6.13	18.25	12.39	6.18	18.81	13.38	6.21	19.94	13.34	6.28	21.07	14.20	6.34
46	11.84	10.01	5.85	13.19	10.75	5.93	13.63	11.39	5.97	14.52	11.73	6.02	14.98	12.66	6.06	15.89	12.61	6.12	16.78	13.42	6.18

● Floor/Ceiling type

Model: ABHG18LVTB × 4

AFR	m ³ /h	3,120
-----	-------------------	-------

Outdoor temperature	Indoor temperature																				
	18			21			23			25			27			29			32		
	°CDB			°CWB			°CDB			°CDB			°CDB			°CDB			°CDB		
	TC	SHC	IP	TC	SHC	IP	TC	SHC	IP	TC	SHC	IP	TC	SHC	IP	TC	SHC	IP	TC	SHC	IP
-15	17.44	13.28	2.78	19.42	13.37	2.82	20.08	14.53	2.84	21.40	14.58	2.87	22.07	15.74	2.88	23.39	15.68	2.92	24.72	16.71	2.94
-10	17.26	13.15	2.79	19.23	13.23	2.83	19.88	14.39	2.84	21.20	14.43	2.87	21.85	15.58	2.89	23.16	15.52	2.92	24.48	16.53	2.94
0	17.10	13.03	2.97	19.05	13.11	3.01	19.69	14.24	3.03	20.99	14.29	3.06	21.64	15.43	3.08	22.95	15.37	3.11	24.24	16.37	3.14
5	17.06	13.00	3.10	19.01	13.07	3.15	19.65	14.21	3.17	20.94	14.25	3.20	21.60	15.40	3.21	22.89	15.33	3.24	24.19	16.33	3.27
10	16.88	12.97	3.48	18.81	13.05	3.54	19.44	14.19	3.56	20.72	14.24	3.59	21.37	15.37	3.61	22.65	15.32	3.64	23.94	16.31	3.69
15	16.40	12.82	3.60	18.25	13.03	3.66	18.89	14.17	3.68	20.12	14.21	3.71	20.74	15.35	3.73	21.99	15.29	3.77	23.23	16.28	3.81
20	16.62	12.94	4.01	18.50	13.16	4.07	19.14	14.31	4.09	20.40	14.35	4.13	21.03	15.50	4.15	22.29	15.44	4.20	23.56	16.44	4.23
25	16.78	12.95	4.75	18.69	13.17	4.83	19.33	14.32	4.85	20.61	14.36	4.90	21.24	15.52	4.92	22.52	15.45	4.97	23.79	16.46	5.02
30	16.45	12.31	5.43	18.33	12.51	5.50	18.96	13.61	5.53	20.19	13.65	5.59	20.82	14.74	5.62	22.07	14.68	5.67	23.32	15.65	5.73
35	15.01	12.03	6.05	16.72	12.30	6.14	17.29	13.37	6.18	18.43	13.41	6.24	19.00	14.49	6.27	20.14	14.43	6.33	21.28	15.37	6.39
40	14.86	11.36	5.73	16.55	11.69	5.81	17.12	12.71	5.85	18.25	12.74	5.90	18.81	13.77	5.93	19.94	13.72	5.99	21.07	14.60	6.05
46	11.84	10.29	5.58	13.19	11.05	5.66	13.63	11.71	5.69	14.52	12.06	5.75	14.98	13.02	5.78	15.89	12.97	5.84	16.78	13.80	5.89

■ Heating capacity (Double twin)

● Compact cassette type

Model: AUHG18LVLB × 4

AFR	m ³ /h	3,200
-----	-------------------	-------

		Indoor temperature											
		°CDB		16		18		20		22		24	
		°CDB	°CWB	TC	IP	TC	IP	TC	IP	TC	IP	TC	IP
Outdoor temperature	-20	-21	10.58	5.90	10.32	6.02	10.07	6.14	9.82	6.27	9.57	6.38	
	-15	-16	16.21	6.81	15.83	6.95	15.44	7.09	15.06	7.23	14.68	7.37	
	-10	-11	18.89	7.23	18.44	7.38	18.00	7.53	17.55	7.68	17.10	7.83	
	-5	-7	20.98	7.54	20.48	7.69	19.98	7.85	19.48	8.01	18.99	8.16	
	0	-2	22.62	7.62	22.08	7.77	21.54	7.93	21.00	8.09	20.47	8.25	
	5	3	25.56	7.63	24.95	7.79	24.35	7.95	23.73	8.10	23.13	8.25	
	7	6	25.83	7.64	25.22	7.80	24.60	7.96	23.99	8.12	23.37	8.28	
	10	8	27.04	7.59	26.39	7.74	25.74	7.91	25.09	8.06	24.46	8.23	
	15	10	28.06	7.59	27.39	7.73	26.72	7.90	26.05	8.07	25.38	8.18	
	20	15	25.25	6.62	24.64	6.75	24.04	6.89	23.44	7.04	22.83	7.13	
	24	18	25.81	6.59	25.19	6.71	24.58	6.86	23.96	7.00	23.35	7.09	

● Slim duct type

Model: ARHG18LLTB × 4

AFR	m ³ /h	3,760
-----	-------------------	-------

		Indoor temperature											
		°CDB		16		18		20		22		24	
		°CDB	°CWB	TC	IP	TC	IP	TC	IP	TC	IP	TC	IP
Outdoor temperature	-20	-21	10.58	5.83	10.32	5.95	10.07	6.07	9.82	6.19	9.57	6.30	
	-15	-16	16.21	6.73	15.83	6.87	15.44	7.01	15.06	7.15	14.68	7.29	
	-10	-11	18.89	7.15	18.44	7.29	18.00	7.44	17.55	7.59	17.10	7.74	
	-5	-7	20.98	7.45	20.48	7.60	19.98	7.76	19.48	7.91	18.99	8.07	
	0	-2	22.62	7.53	22.08	7.68	21.54	7.84	21.00	8.00	20.47	8.15	
	5	3	25.56	7.55	24.95	7.70	24.35	7.86	23.73	8.00	23.13	8.16	
	7	6	25.83	7.55	25.22	7.71	24.60	7.87	23.99	8.02	23.37	8.18	
	10	8	27.04	7.50	26.39	7.65	25.74	7.82	25.09	7.97	24.46	8.13	
	15	10	28.06	7.50	27.39	7.64	26.72	7.81	26.05	7.97	25.38	8.08	
	20	15	25.25	6.54	24.64	6.67	24.04	6.81	23.44	6.95	22.83	7.04	
	24	18	25.81	6.51	25.19	6.63	24.58	6.78	23.96	6.92	23.35	7.01	

● Floor/Ceiling type

Model: ABHG18LVTB × 4

AFR	m ³ /h	3,120
-----	-------------------	-------

		Indoor temperature											
		°CDB		16		18		20		22		24	
		°CDB	°CWB	TC	IP	TC	IP	TC	IP	TC	IP	TC	IP
Outdoor temperature	-20	-21	10.58	5.90	10.32	6.02	10.07	6.14	9.82	6.27	9.57	6.38	
	-15	-16	16.21	6.81	15.83	6.95	15.44	7.09	15.06	7.23	14.68	7.37	
	-10	-11	18.89	7.23	18.44	7.38	18.00	7.53	17.55	7.68	17.10	7.83	
	-5	-7	20.98	7.54	20.48	7.69	19.98	7.85	19.48	8.01	18.99	8.16	
	0	-2	22.62	7.62	22.08	7.77	21.54	7.93	21.00	8.09	20.47	8.25	
	5	3	25.56	7.63	24.95	7.79	24.35	7.95	23.73	8.10	23.13	8.25	
	7	6	25.83	7.64	25.22	7.80	24.60	7.96	23.99	8.12	23.37	8.28	
	10	8	27.04	7.59	26.39	7.74	25.74	7.91	25.09	8.06	24.46	8.23	
	15	10	28.06	7.59	27.39	7.73	26.72	7.90	26.05	8.07	25.38	8.18	
	20	15	25.25	6.62	24.64	6.75	24.04	6.89	23.44	7.04	22.83	7.13	
	24	18	25.81	6.59	25.19	6.71	24.58	6.86	23.96	7.00	23.35	7.09	

6-2. Model: AOHG90LRLA

TC: Total Capacity, SHC: Sensible Heat Capacity, IP: Input Power

■ Cooling capacity (Twin)

● Cassette type

Model: AUHG45LRLA × 2

AFR	m ³ /h												3,800					
-----	-------------------	--	--	--	--	--	--	--	--	--	--	--	-------	--	--	--	--	--

Outdoor temperature	Indoor temperature																				
	18			21			23			25			27			29			32		
	12			15			16			18			19			21			23		
	°CDB	TC	SHC	IP	TC	SHC	IP	TC	SHC	IP	TC	SHC	IP	TC	SHC	IP	TC	SHC	IP	TC	SHC
-15	20.19	15.87	3.07	22.49	15.97	3.13	23.25	17.36	3.15	24.78	17.43	3.18	25.55	18.81	3.19	27.08	18.73	3.23	28.62	19.96	3.26
-10	19.98	15.71	3.08	22.27	15.81	3.14	23.02	17.19	3.15	24.55	17.24	3.18	25.30	18.62	3.20	26.82	18.55	3.23	28.34	19.76	3.26
0	19.80	15.57	3.29	22.05	15.66	3.33	22.80	17.02	3.35	24.30	17.08	3.38	25.05	18.44	3.41	26.57	18.37	3.44	28.07	19.56	3.47
5	19.75	15.53	3.43	22.01	15.62	3.48	22.75	16.98	3.50	24.25	17.03	3.54	25.01	18.40	3.56	26.51	18.32	3.59	28.01	19.52	3.62
10	19.55	15.50	3.85	21.78	15.60	3.91	22.51	16.95	3.94	24.00	17.01	3.97	24.74	18.37	4.00	26.23	18.31	4.03	27.71	19.49	4.08
15	18.99	15.32	3.99	21.14	15.58	4.05	21.87	16.93	4.07	23.30	16.98	4.11	24.02	18.34	4.13	25.47	18.27	4.17	26.90	19.45	4.22
20	19.24	15.47	4.44	21.42	15.73	4.51	22.17	17.09	4.52	23.62	17.14	4.57	24.35	18.53	4.60	25.81	18.45	4.64	27.28	19.65	4.68
25	19.42	15.47	5.26	21.64	15.73	5.34	22.39	17.11	5.37	23.86	17.16	5.42	24.60	18.54	5.45	26.07	18.47	5.50	27.55	19.67	5.56
30	19.05	14.71	6.01	21.22	14.95	6.09	21.95	16.26	6.12	23.38	16.31	6.19	24.11	17.62	6.22	25.55	17.54	6.27	27.00	18.70	6.34
35	17.38	14.37	6.70	19.35	14.70	6.79	20.02	15.98	6.84	21.35	16.03	6.91	22.00	17.31	6.93	23.32	17.24	7.01	24.65	18.37	7.08
40	17.21	13.57	6.34	19.17	13.96	6.43	19.82	15.19	6.48	21.13	15.23	6.53	21.78	16.45	6.56	23.09	16.39	6.63	24.39	17.45	6.70
46	13.70	12.30	6.18	15.27	13.21	6.26	15.78	14.00	6.30	16.81	14.41	6.36	17.35	15.56	6.40	18.39	15.49	6.46	19.42	16.49	6.52

● Duct type

Model: ARHG45LMLA × 2

AFR	m ³ /h												4,200					
-----	-------------------	--	--	--	--	--	--	--	--	--	--	--	-------	--	--	--	--	--

Outdoor temperature	Indoor temperature																				
	18			21			23			25			27			29			32		
	12			15			16			18			19			21			23		
	°CDB	TC	SHC	IP	TC	SHC	IP	TC	SHC	IP	TC	SHC	IP	TC	SHC	IP	TC	SHC	IP	TC	SHC
-15	20.19	16.26	3.23	22.49	16.36	3.28	23.25	17.79	3.30	24.78	17.85	3.34	25.55	19.27	3.35	27.08	19.19	3.39	28.62	20.45	3.42
-10	19.98	16.10	3.24	22.27	16.20	3.29	23.02	17.61	3.30	24.55	17.66	3.34	25.30	19.08	3.36	26.82	19.00	3.39	28.34	20.24	3.42
0	19.80	15.95	3.45	22.05	16.05	3.50	22.80	17.44	3.52	24.30	17.50	3.55	25.05	18.89	3.58	26.57	18.81	3.61	28.07	20.04	3.65
5	19.75	15.91	3.60	22.01	16.00	3.66	22.75	17.40	3.68	24.25	17.45	3.72	25.01	18.85	3.74	26.51	18.77	3.77	28.01	20.00	3.81
10	19.55	15.88	4.05	21.78	15.98	4.11	22.51	17.37	4.14	24.00	17.43	4.17	24.74	18.81	4.20	26.23	18.75	4.24	27.71	19.96	4.29
15	18.99	15.69	4.19	21.14	15.96	4.25	21.87	17.34	4.28	23.30	17.39	4.31	24.02	18.79	4.34	25.47	18.72	4.38	26.90	19.93	4.43
20	19.24	15.84	4.66	21.42	16.11	4.74	22.17	17.51	4.75	23.62	17.56	4.80	24.35	18.98	4.83	25.81	18.90	4.88	27.28	20.13	4.92
25	19.42	15.85	5.53	21.64	16.12	5.61	22.39	17.53	5.64	23.86	17.58	5.70	24.60	19.00	5.73	26.07	18.92	5.78	27.55	20.15	5.84
30	19.05	15.06	6.31	21.22	15.32	6.40	21.95	16.66	6.43	23.38	16.71	6.50	24.11	18.05	6.53	25.55	17.97	6.59	27.00	19.16	6.66
35	17.38	14.72	7.03	19.35	15.06	7.14	20.02	16.37	7.18	21.35	16.42	7.26	22.00	17.74	7.29	23.32	17.66	7.36	24.65	18.82	7.43
40	17.21	13.90	6.66	19.17	14.31	6.75	19.82	15.56	6.80	21.13	15.60	6.86	21.78	16.85	6.89	23.09	16.79	6.97	24.39	17.88	7.04
46	13.70	12.60	6.49	15.27	13.53	6.58	15.78	14.34	6.62	16.81	14.76	6.68	17.35	15.94	6.72	18.39	15.87	6.79	19.42	16.89	6.85

● Ceiling type

Model: ABHG45LRRTA × 2

AFR	m ³ /h												4,200					
-----	-------------------	--	--	--	--	--	--	--	--	--	--	--	-------	--	--	--	--	--

Outdoor temperature	Indoor temperature																				
	18			21			23			25			27			29			32		
	12			15			16			18			19			21			23		
	°CDB	TC	SHC	IP	TC	SHC	IP	TC	SHC	IP	TC	SHC	IP	TC	SHC	IP	TC	SHC	IP	TC	SHC
-15	20.19	15.87	3.07	22.49	15.97	3.13	23.25	17.36	3.15	24.78	17.43	3.18	25.55	18.81	3.19	27.08	18.73	3.23	28.62	19.96	3.26
-10	19.98	15.71	3.08	22.27	15.81	3.14	23.02	17.19	3.15	24.55	17.24	3.18	25.30	18.62	3.20	26.82	18.55	3.23	28.34	19.76	3.26
0	19.80	15.57	3.29	22.05	15.66	3.33	22.80	17.02	3.35	24.30	17.08	3.38	25.05	18.44	3.41	26.57	18.37	3.44	28.07	19.56	3.47
5	19.75	15.53	3.43	22.01	15.62	3.48	22.75	16.98	3.50	24.25	17.03	3.54	25.01	18.40	3.56	26.51	18.32	3.59	28.01	19.52	3.62
10	19.55	15.50	3.85	21.78	15.60	3.91	22.51	16.95	3.94	24.00	17.01	3.97	24.74	18.37	4.00	26.23	18.31	4.03	27.71	19.49	4.08
15	18.99	15.32	3.99	21.14	15.58	4.05	21.87	16.93	4.07	23.30	16.98	4.11	24.02	18.34	4.13	25.47	18.27	4.17	26.90	19.45	4.22
20	19.24	15.47	4.44	21.42	15.73	4.51	22.17	17.09	4.52	23.62	17.14	4.57	24.35	18.53	4.60	25.81	18.45	4.64	27.28	19.65	4.68
25	19.42	15.47	5.26	21.64	15.73	5.34	22.39	17.11	5.37	23.86	17.16	5.42	24.60	18.54	5.45	26.07	18.47	5.50	27.55	19.67	5.56
30	19.05	14.71	6.01	21.22	14.95	6.09	21.95	16.26	6.12	23.38	16.31	6.19	24.11	17.62	6.22	25.55	17.54	6.27	27.00	18.70	6.34
35	17.38	14.37	6.70	19.35	14.70	6.79	20.02	15.98	6.84	21.35	16.03	6.91	22.00	17.31	6.93	23.32	17.24	7.01	24.65	18.37	7.08
40	17.21	13.57	6.34	19.17	13.96	6.43	19.82	15.19	6.48	21.13	15.23	6.53	21.78	16.45	6.56	23.09	16.39	6.63	24.39	17.45	6.70
46	13.70	12.30	6.18	15.27	13.21	6.26	15.78	14.00	6.30	16.81	14.41	6.36	17.35	15.56	6.40	18.39	15.49	6.46	19.42	16.49	6.52

■ Heating capacity (Twin)

● Cassette type

Model: AUHG45LRLA × 2

AFR	m ³ /h	3,800
-----	-------------------	-------

		Indoor temperature											
		°CDB		16		18		20		22		24	
		°CDB	°CWB	TC	IP	TC	IP	TC	IP	TC	IP	TC	IP
Outdoor temperature	-20	-21	12.77	6.58	12.47	6.71	12.16	6.85	11.86	6.99	11.56	7.11	
	-15	-16	19.57	7.59	19.11	7.75	18.64	7.91	18.18	8.07	17.72	8.22	
	-10	-11	22.81	8.07	22.27	8.23	21.73	8.40	21.19	8.57	20.65	8.74	
	-5	-7	25.33	8.41	24.73	8.58	24.12	8.76	23.52	8.93	22.92	9.11	
	0	-2	27.31	8.50	26.66	8.67	26.00	8.85	25.35	9.03	24.71	9.19	
	5	3	30.86	8.52	30.12	8.70	29.39	8.87	28.65	9.03	27.92	9.17	
	7	6	31.19	8.52	30.44	8.70	29.70	8.88	28.96	9.06	28.22	9.18	
	10	8	32.64	8.47	31.86	8.64	31.08	8.82	30.29	8.99	29.53	9.18	
	15	10	33.88	8.46	33.07	8.63	32.26	8.81	31.45	9.00	30.65	9.12	
	20	15	30.48	7.39	29.75	7.53	29.02	7.69	28.30	7.85	27.57	7.95	
24	18	31.16	7.35	30.42	7.49	29.67	7.65	28.93	7.81	28.20	7.91		

● Duct type

Model: ARHG45LMLA × 2

AFR	m ³ /h	4,200
-----	-------------------	-------

		Indoor temperature											
		°CDB		16		18		20		22		27	
		°CDB	°CWB	TC	IP	TC	IP	TC	IP	TC	IP	TC	IP
Outdoor temperature	-20	-21	12.77	6.92	12.47	7.06	12.16	7.21	11.86	7.35	11.56	7.48	
	-15	-16	19.57	7.98	19.11	8.15	18.64	8.32	18.18	8.48	17.72	8.65	
	-10	-11	22.81	8.48	22.27	8.66	21.73	8.83	21.19	9.01	20.65	9.18	
	-5	-7	25.33	8.84	24.73	9.03	24.12	9.21	23.52	9.39	22.92	9.58	
	0	-2	27.31	8.93	26.66	9.12	26.00	9.31	25.35	9.49	24.71	9.66	
	5	3	30.86	8.96	30.12	9.14	29.39	9.33	28.65	9.50	27.92	9.64	
	7	6	31.19	8.96	30.44	9.15	29.70	9.34	28.96	9.52	28.22	9.65	
	10	8	32.64	8.90	31.86	9.08	31.08	9.28	30.29	9.45	29.53	9.65	
	15	10	33.88	8.90	33.07	9.07	32.26	9.27	31.45	9.46	30.65	9.59	
	20	15	30.48	7.77	29.75	7.91	29.02	8.08	28.30	8.25	27.57	8.36	
24	18	31.16	7.72	30.42	7.87	29.67	8.04	28.93	8.21	28.20	8.32		

● Ceiling type

Model: ABHG45LRTA × 2

AFR	m ³ /h	4,200
-----	-------------------	-------

		Indoor temperature											
		°CDB		16		18		20		22		24	
		°CDB	°CWB	TC	IP	TC	IP	TC	IP	TC	IP	TC	IP
Outdoor temperature	-20	-21	12.77	6.58	12.47	6.71	12.16	6.85	11.86	6.99	11.56	7.11	
	-15	-16	19.57	7.59	19.11	7.75	18.64	7.91	18.18	8.07	17.72	8.22	
	-10	-11	22.81	8.07	22.27	8.23	21.73	8.40	21.19	8.57	20.65	8.74	
	-5	-7	25.33	8.41	24.73	8.58	24.12	8.76	23.52	8.93	22.92	9.11	
	0	-2	27.31	8.50	26.66	8.67	26.00	8.85	25.35	9.03	24.71	9.19	
	5	3	30.86	8.52	30.12	8.70	29.39	8.87	28.65	9.03	27.92	9.17	
	7	6	31.19	8.52	30.44	8.70	29.70	8.88	28.96	9.06	28.22	9.18	
	10	8	32.64	8.47	31.86	8.64	31.08	8.82	30.29	8.99	29.53	9.18	
	15	10	33.88	8.46	33.07	8.63	32.26	8.81	31.45	9.00	30.65	9.12	
	20	15	30.48	7.39	29.75	7.53	29.02	7.69	28.30	7.85	27.57	7.95	
24	18	31.16	7.35	30.42	7.49	29.67	7.65	28.93	7.81	28.20	7.91		

■ Cooling capacity (Triple)

● Cassette type

Model: AUHG30LRLE × 3

AFR	m ³ /h	4,800
-----	-------------------	-------

		Indoor temperature																							
°CDB		18			21			23			25			27			29			32					
°CWB		12			15			16			18			19			21			23					
Outdoor temperature	°CDB	TC	SHC	IP	TC	SHC	IP	TC	SHC	IP	TC	SHC	IP	TC	SHC	IP	TC	SHC	IP	TC	SHC	IP	TC	SHC	IP
		kW			kW			kW			kW			kW			kW			kW			kW		
-15		20.19	17.51	2.75	22.49	17.62	2.79	23.25	19.15	2.81	24.78	19.22	2.84	25.55	20.75	2.85	27.08	20.66	2.89	28.62	22.02	2.91			
-10		19.98	17.33	2.76	22.27	17.44	2.80	23.02	18.97	2.81	24.55	19.02	2.84	25.30	20.54	2.86	26.82	20.46	2.89	28.34	21.79	2.91			
0		19.80	17.17	2.94	22.05	17.28	2.98	22.80	18.78	3.00	24.30	18.84	3.03	25.05	20.34	3.05	26.57	20.26	3.07	28.07	21.58	3.10			
5		19.75	17.13	3.06	22.01	17.23	3.11	22.75	18.73	3.13	24.25	18.79	3.16	25.01	20.29	3.18	26.51	20.21	3.21	28.01	21.53	3.24			
10		19.55	17.10	3.45	21.78	17.21	3.50	22.51	18.70	3.52	24.00	18.77	3.55	24.74	20.26	3.57	26.23	20.19	3.61	27.71	21.50	3.65			
15		18.99	16.90	3.56	21.14	17.18	3.62	21.87	18.67	3.64	23.30	18.73	3.67	24.02	20.23	3.70	25.47	20.15	3.73	26.90	21.46	3.77			
20		19.24	17.06	3.97	21.42	17.35	4.03	22.17	18.86	4.04	23.62	18.91	4.09	24.35	20.44	4.11	25.81	20.35	4.15	27.28	21.67	4.19			
25		19.42	17.07	4.71	21.64	17.36	4.78	22.39	18.87	4.80	23.86	18.93	4.85	24.60	20.45	4.87	26.07	20.37	4.92	27.55	21.70	4.97			
30		19.05	16.22	5.37	21.22	16.49	5.45	21.95	17.94	5.47	23.38	17.99	5.54	24.11	19.43	5.56	25.55	19.35	5.61	27.00	20.63	5.67			
35		17.38	15.85	5.99	19.35	16.21	6.08	20.02	17.63	6.11	21.35	17.68	6.18	22.00	19.10	6.20	23.32	19.02	6.27	24.65	20.26	6.33			
40		17.21	14.97	5.67	19.17	15.40	5.75	19.82	16.75	5.79	21.13	16.80	5.84	21.78	18.15	5.87	23.09	18.08	5.93	24.39	19.25	5.99			
46		13.70	13.57	5.53	15.27	14.57	5.60	15.78	15.44	5.63	16.81	15.90	5.69	17.35	17.17	5.72	18.39	17.09	5.78	19.42	18.19	5.83			

● Duct type

Model: ARHG30LMLE × 3

AFR	m ³ /h	5,700
-----	-------------------	-------

		Indoor temperature																							
°CDB		18			21			23			25			27			29			32					
°CWB		12			15			16			18			19			21			23					
Outdoor temperature	°CDB	TC	SHC	IP	TC	SHC	IP	TC	SHC	IP	TC	SHC	IP	TC	SHC	IP	TC	SHC	IP	TC	SHC	IP	TC	SHC	IP
		kW			kW			kW			kW			kW			kW			kW			kW		
-15		20.19	15.78	3.03	22.49	15.88	3.08	23.25	17.26	3.10	24.78	17.32	3.13	25.55	18.69	3.14	27.08	18.62	3.18	28.62	19.84	3.21			
-10		19.98	15.62	3.04	22.27	15.72	3.09	23.02	17.09	3.10	24.55	17.14	3.13	25.30	18.51	3.15	26.82	18.44	3.18	28.34	19.64	3.21			
0		19.80	15.47	3.24	22.05	15.57	3.28	22.80	16.92	3.30	24.30	16.98	3.34	25.05	18.33	3.36	26.57	18.25	3.39	28.07	19.45	3.42			
5		19.75	15.44	3.38	22.01	15.52	3.43	22.75	16.88	3.45	24.25	16.93	3.49	25.01	18.29	3.51	26.51	18.21	3.54	28.01	19.40	3.57			
10		19.55	15.41	3.80	21.78	15.50	3.86	22.51	16.85	3.88	24.00	16.91	3.92	24.74	18.26	3.94	26.23	18.20	3.98	27.71	19.37	4.02			
15		18.99	15.23	3.93	21.14	15.48	3.99	21.87	16.83	4.01	23.30	16.88	4.05	24.02	18.23	4.07	25.47	18.16	4.11	26.90	19.33	4.16			
20		19.24	15.37	4.37	21.42	15.63	4.45	22.17	16.99	4.46	23.62	17.04	4.51	24.35	18.41	4.53	25.81	18.34	4.58	27.28	19.53	4.62			
25		19.42	15.38	5.19	21.64	15.64	5.27	22.39	17.00	5.29	23.86	17.05	5.35	24.60	18.43	5.37	26.07	18.36	5.43	27.55	19.55	5.48			
30		19.05	14.62	5.92	21.22	14.86	6.01	21.95	16.16	6.03	23.38	16.21	6.10	24.11	17.51	6.13	25.55	17.44	6.19	27.00	18.59	6.26			
35		17.38	14.28	6.60	19.35	14.61	6.70	20.02	15.89	6.74	21.35	15.93	6.81	22.00	17.21	6.84	23.32	17.14	6.91	24.65	18.26	6.98			
40		17.21	13.49	6.25	19.17	13.88	6.34	19.82	15.09	6.39	21.13	15.14	6.44	21.78	16.35	6.47	23.09	16.29	6.54	24.39	17.35	6.61			
46		13.70	12.22	6.09	15.27	13.13	6.17	15.78	13.91	6.21	16.81	14.32	6.27	17.35	15.47	6.31	18.39	15.40	6.37	19.42	16.39	6.43			

● Ceiling type

Model: ABHG30LRTE × 3

AFR	m ³ /h	4,980
-----	-------------------	-------

		Indoor temperature																							
°CDB		18			21			23			25			27			29			32					
°CWB		12			15			16			18			19			21			23					
Outdoor temperature	°CDB	TC	SHC	IP	TC	SHC	IP	TC	SHC	IP	TC	SHC	IP	TC	SHC	IP	TC	SHC	IP	TC	SHC	IP	TC	SHC	IP
		kW			kW			kW			kW			kW			kW			kW			kW		
-15		20.19	17.51	2.75	22.49	17.62	2.79	23.25	19.15	2.81	24.78	19.22	2.84	25.55	20.75	2.85	27.08	20.66	2.89	28.62	22.02	2.91			
-10		19.98	17.33	2.76	22.27	17.44	2.80	23.02	18.97	2.81	24.55	19.02	2.84	25.30	20.54	2.86	26.82	20.46	2.89	28.34	21.79	2.91			
0		19.80	17.17	2.94	22.05	17.28	2.98	22.80	18.78	3.00	24.30	18.84	3.03	25.05	20.34	3.05	26.57	20.26	3.07	28.07	21.58	3.10			
5		19.75	17.13	3.06	22.01	17.23	3.11	22.75	18.73	3.13	24.25	18.79	3.16	25.01	20.29	3.18	26.51	20.21	3.21	28.01	21.53	3.24			
10		19.55	17.10	3.45	21.78	17.21	3.50	22.51	18.70	3.52	24.00	18.77	3.55	24.74	20.26	3.57	26.23	20.19	3.61	27.71	21.50	3.65			
15		18.99	16.90	3.56	21.14	17.18	3.62	21.87	18.67	3.64	23.30	18.73	3.67	24.02	20.23	3.70	25.47	20.15	3.73	26.90	21.46	3.77			
20		19.24	17.06	3.97	21.42	17.35	4.03	22.17	18.86	4.04	23.62	18.91	4.09	24.35	20.44	4.11	25.81	20.35	4.15	27.28	21.67	4.19			
25		19.42	17.07	4.71	21.64	17.36	4.78	22.39	18.87	4.80	23.86	18.93	4.85	24.60	20.45	4.87	26.07	20.37	4.92	27.55	21.70	4.97			
30		19.05	16.22	5.37	21.22	16.49	5.45	21.95	17.94	5.47	23.38	17.99	5.54	24.11	19.43	5.56	25.55	19.35	5.61	27.00	20.63	5.67			
35		17.38	15.85	5.99	19.35	16.21	6.08	20.02	17.63	6.11	21.35	17.68	6.18	22.00	19.10	6.20	23.32	19.02	6.27	24.65	20.26	6.33			
40		17.21	14.97	5.67	19.17	15.40	5.75	19.82	16.75	5.79	21.13	16.80	5.84	21.78	18.15	5.87	23.09	18.08	5.93	24.39	19.25	5.99			
46		13.70	13.57	5.53	15.27	14.57	5.60	15.78	15.44	5.63	16.81	15.90	5.69	17.35	17.17	5.72	18.39	17.09	5.78	19.42	18.19	5.83			

■ Heating capacity (Triple)

● Cassette type

Model: AUHG30LRLE × 3

AFR	m ³ /h	4,800
-----	-------------------	-------

		Indoor temperature											
		°CDB		16		18		20		22		24	
		°CDB	°CWB	TC	IP	TC	IP	TC	IP	TC	IP	TC	IP
Outdoor temperature	-20	-21	12.77	6.56	12.47	6.70	12.16	6.83	11.86	6.97	11.56	7.09	
	-15	-16	19.57	7.57	19.11	7.73	18.64	7.89	18.18	8.04	17.72	8.20	
	-10	-11	22.81	8.04	22.27	8.21	21.73	8.38	21.19	8.54	20.65	8.71	
	-5	-7	25.33	8.39	24.73	8.56	24.12	8.73	23.52	8.91	22.92	9.08	
	0	-2	27.31	8.47	26.66	8.65	26.00	8.83	25.35	9.00	24.71	9.16	
	5	3	30.86	8.49	30.12	8.67	29.39	8.85	28.65	9.01	27.92	9.15	
	7	6	31.19	8.50	30.44	8.68	29.70	8.86	28.96	9.03	28.22	9.15	
	10	8	32.64	8.45	31.86	8.61	31.08	8.80	30.29	8.97	29.53	9.15	
	15	10	33.88	8.44	33.07	8.61	32.26	8.79	31.45	8.97	30.65	9.10	
	20	15	30.48	7.37	29.75	7.51	29.02	7.67	28.30	7.83	27.57	7.93	
	24	18	31.16	7.33	30.42	7.47	29.67	7.63	28.93	7.79	28.20	7.89	

● Duct type

Model: ARHG30LMLE × 3

AFR	m ³ /h	6,300
-----	-------------------	-------

		Indoor temperature											
		°CDB		16		18		20		22		24	
		°CDB	°CWB	TC	IP	TC	IP	TC	IP	TC	IP	TC	IP
Outdoor temperature	-20	-21	12.77	6.73	12.47	6.87	12.16	7.01	11.86	7.15	11.56	7.28	
	-15	-16	19.57	7.77	19.11	7.93	18.64	8.09	18.18	8.25	17.72	8.41	
	-10	-11	22.81	8.25	22.27	8.42	21.73	8.59	21.19	8.77	20.65	8.94	
	-5	-7	25.33	8.60	24.73	8.78	24.12	8.96	23.52	9.14	22.92	9.32	
	0	-2	27.31	8.69	26.66	8.87	26.00	9.05	25.35	9.24	24.71	9.40	
	5	3	30.86	8.71	30.12	8.90	29.39	9.08	28.65	9.24	27.92	9.38	
	7	6	31.19	8.72	30.44	8.90	29.70	9.08	28.96	9.27	28.22	9.39	
	10	8	32.64	8.66	31.86	8.84	31.08	9.03	30.29	9.20	29.53	9.39	
	15	10	33.88	8.66	33.07	8.83	32.26	9.02	31.45	9.21	30.65	9.33	
	20	15	30.48	7.56	29.75	7.70	29.02	7.87	28.30	8.03	27.57	8.13	
	24	18	31.16	7.52	30.42	7.66	29.67	7.83	28.93	7.99	28.20	8.09	

● Ceiling type

Model: ABHG30LRTE × 3

AFR	m ³ /h	4,980
-----	-------------------	-------

		Indoor temperature											
		°CDB		16		18		20		22		24	
		°CDB	°CWB	TC	IP	TC	IP	TC	IP	TC	IP	TC	IP
Outdoor temperature	-20	-21	12.77	6.56	12.47	6.70	12.16	6.83	11.86	6.97	11.56	7.09	
	-15	-16	19.57	7.57	19.11	7.73	18.64	7.89	18.18	8.04	17.72	8.20	
	-10	-11	22.81	8.04	22.27	8.21	21.73	8.38	21.19	8.54	20.65	8.71	
	-5	-7	25.33	8.39	24.73	8.56	24.12	8.73	23.52	8.91	22.92	9.08	
	0	-2	27.31	8.47	26.66	8.65	26.00	8.83	25.35	9.00	24.71	9.16	
	5	3	30.86	8.49	30.12	8.67	29.39	8.85	28.65	9.01	27.92	9.15	
	7	6	31.19	8.50	30.44	8.68	29.70	8.86	28.96	9.03	28.22	9.15	
	10	8	32.64	8.45	31.86	8.61	31.08	8.80	30.29	8.97	29.53	9.15	
	15	10	33.88	8.44	33.07	8.61	32.26	8.79	31.45	8.97	30.65	9.10	
	20	15	30.48	7.37	29.75	7.51	29.02	7.67	28.30	7.83	27.57	7.93	
	24	18	31.16	7.33	30.42	7.47	29.67	7.63	28.93	7.79	28.20	7.89	

■ Cooling capacity (Double twin)

● Compact cassette type

Model: AUHG22LVLA × 4

AFR	m ³ /h	3,720
-----	-------------------	-------

	Indoor temperature																					
	18			21			23			25			27			29			32			
	12			15			16			18			19			21			23			
	°CDB	SHC	IP	TC	SHC	IP	TC	SHC	IP	TC	SHC	IP	TC	SHC	IP	TC	SHC	IP	TC	SHC	IP	
Outdoor temperature	°CDB	kW			kW			kW			kW			kW			kW			kW		
	-15	20.19	15.68	3.14	22.49	15.78	3.20	23.25	17.16	3.22	24.78	17.22	3.25	25.55	18.58	3.26	27.08	18.51	3.30	28.62	19.72	3.33
	-10	19.98	15.53	3.15	22.27	15.62	3.21	23.02	16.99	3.22	24.55	17.04	3.25	25.30	18.40	3.27	26.82	18.33	3.30	28.34	19.52	3.33
	0	19.80	15.38	3.36	22.05	15.48	3.40	22.80	16.82	3.43	24.30	16.88	3.46	25.05	18.22	3.48	26.57	18.14	3.52	28.07	19.33	3.55
	5	19.75	15.34	3.50	22.01	15.43	3.56	22.75	16.78	3.58	24.25	16.83	3.62	25.01	18.18	3.64	26.51	18.10	3.67	28.01	19.28	3.71
	10	19.55	15.31	3.94	21.78	15.41	4.00	22.51	16.75	4.03	24.00	16.81	4.06	24.74	18.15	4.09	26.23	18.09	4.12	27.71	19.25	4.17
	15	18.99	15.14	4.08	21.14	15.39	4.14	21.87	16.72	4.16	23.30	16.77	4.20	24.02	18.12	4.22	25.47	18.05	4.26	26.90	19.22	4.31
	20	19.24	15.28	4.54	21.42	15.54	4.61	22.17	16.89	4.62	23.62	16.94	4.67	24.35	18.30	4.70	25.81	18.23	4.75	27.28	19.41	4.79
	25	19.42	15.29	5.38	21.64	15.55	5.46	22.39	16.90	5.49	23.86	16.95	5.54	24.60	18.32	5.57	26.07	18.25	5.63	27.55	19.43	5.68
	30	19.05	14.53	6.14	21.22	14.77	6.23	21.95	16.06	6.26	23.38	16.11	6.33	24.11	17.40	6.36	25.55	17.33	6.41	27.00	18.47	6.49
	35	17.38	14.20	6.85	19.35	14.52	6.95	20.02	15.79	6.99	21.35	15.84	7.06	22.00	17.11	7.09	23.32	17.03	7.16	24.65	18.15	7.23
	40	17.21	13.41	6.48	19.17	13.80	6.57	19.82	15.00	6.62	21.13	15.05	6.68	21.78	16.25	6.71	23.09	16.19	6.78	24.39	17.24	6.85
46	13.70	12.15	6.32	15.27	13.05	6.40	15.78	13.83	6.44	16.81	14.24	6.50	17.35	15.37	6.54	18.39	15.31	6.61	19.42	16.29	6.67	

● Duct type

Model: ARHG22LMLA × 4

AFR	m ³ /h	4,400
-----	-------------------	-------

	Indoor temperature																					
	18			21			23			25			27			29			32			
	12			15			16			18			19			21			23			
	°CDB	SHC	IP	TC	SHC	IP	TC	SHC	IP	TC	SHC	IP	TC	SHC	IP	TC	SHC	IP	TC	SHC	IP	
Outdoor temperature	°CDB	kW			kW			kW			kW			kW			kW			kW		
	-15	20.19	16.11	3.08	22.49	16.21	3.13	23.25	17.62	3.15	24.78	17.68	3.18	25.55	19.08	3.19	27.08	19.01	3.23	28.62	20.26	3.26
	-10	19.98	15.95	3.09	22.27	16.05	3.14	23.02	17.45	3.15	24.55	17.50	3.18	25.30	18.90	3.20	26.82	18.82	3.23	28.34	20.05	3.26
	0	19.80	15.80	3.29	22.05	15.90	3.33	22.80	17.27	3.36	24.30	17.33	3.39	25.05	18.71	3.41	26.57	18.64	3.44	28.07	19.85	3.47
	5	19.75	15.76	3.43	22.01	15.85	3.49	22.75	17.23	3.51	24.25	17.28	3.54	25.01	18.67	3.56	26.51	18.59	3.60	28.01	19.81	3.63
	10	19.55	15.73	3.86	21.78	15.83	3.92	22.51	17.20	3.94	24.00	17.26	3.98	24.74	18.64	4.00	26.23	18.57	4.04	27.71	19.78	4.09
	15	18.99	15.55	3.99	21.14	15.80	4.05	21.87	17.18	4.08	23.30	17.23	4.11	24.02	18.61	4.14	25.47	18.54	4.17	26.90	19.74	4.22
	20	19.24	15.69	4.44	21.42	15.96	4.51	22.17	17.35	4.53	23.62	17.40	4.58	24.35	18.80	4.60	25.81	18.72	4.65	27.28	19.94	4.69
	25	19.42	15.70	5.27	21.64	15.97	5.35	22.39	17.36	5.38	23.86	17.41	5.43	24.60	18.82	5.46	26.07	18.74	5.51	27.55	19.96	5.56
	30	19.05	14.92	6.01	21.22	15.17	6.10	21.95	16.50	6.13	23.38	16.55	6.20	24.11	17.87	6.22	25.55	17.80	6.28	27.00	18.97	6.35
	35	17.38	14.58	6.70	19.35	14.91	6.80	20.02	16.22	6.84	21.35	16.27	6.91	22.00	17.57	6.94	23.32	17.50	7.01	24.65	18.64	7.08
	40	17.21	13.77	6.35	19.17	14.17	6.43	19.82	15.41	6.48	21.13	15.45	6.54	21.78	16.69	6.57	23.09	16.63	6.64	24.39	17.71	6.71
46	13.70	12.48	6.19	15.27	13.40	6.27	15.78	14.20	6.31	16.81	14.62	6.37	17.35	15.79	6.41	18.39	15.72	6.47	19.42	16.73	6.53	

● Floor/Ceiling type

Model: ABHG22LVTA × 4

AFR	m ³ /h	3,920
-----	-------------------	-------

	Indoor temperature																					
	18			21			23			25			27			29			32			
	12			15			16			18			19			21			23			
	°CDB	SHC	IP	TC	SHC	IP	TC	SHC	IP	TC	SHC	IP	TC	SHC	IP	TC	SHC	IP	TC	SHC	IP	
Outdoor temperature	°CDB	kW			kW			kW			kW			kW			kW			kW		
	-15	20.19	15.68	3.14	22.49	15.78	3.20	23.25	17.16	3.22	24.78	17.22	3.25	25.55	18.58	3.26	27.08	18.51	3.30	28.62	19.72	3.33
	-10	19.98	15.53	3.15	22.27	15.62	3.21	23.02	16.99	3.22	24.55	17.04	3.25	25.30	18.40	3.27	26.82	18.33	3.30	28.34	19.52	3.33
	0	19.80	15.38	3.36	22.05	15.48	3.40	22.80	16.82	3.43	24.30	16.88	3.46	25.05	18.22	3.48	26.57	18.14	3.52	28.07	19.33	3.55
	5	19.75	15.34	3.50	22.01	15.43	3.56	22.75	16.78	3.58	24.25	16.83	3.62	25.01	18.18	3.64	26.51	18.10	3.67	28.01	19.28	3.71
	10	19.55	15.31	3.94	21.78	15.41	4.00	22.51	16.75	4.03	24.00	16.81	4.06	24.74	18.15	4.09	26.23	18.09	4.12	27.71	19.25	4.17
	15	18.99	15.14	4.08	21.14	15.39	4.14	21.87	16.72	4.16	23.30	16.77	4.20	24.02	18.12	4.22	25.47	18.05	4.26	26.90	19.22	4.31
	20	19.24	15.28	4.54	21.42	15.54	4.61	22.17	16.89	4.62	23.62	16.94	4.67	24.35	18.30	4.70	25.81	18.23	4.75	27.28	19.41	4.79
	25	19.42	15.29	5.38	21.64	15.55	5.46	22.39	16.90	5.49	23.86	16.95	5.54	24.60	18.32	5.57	26.07	18.25	5.63	27.55	19.43	5.68
	30	19.05	14.53	6.14	21.22	14.77	6.23	21.95	16.06	6.26	23.38	16.11	6.33	24.11	17.40	6.36	25.55	17.33	6.41	27.00	18.47	6.49
	35	17.38	14.20	6.85	19.35	14.52	6.95	20.02	15.79	6.99	21.35	15.84	7.06	22.00	17.11	7.09	23.32	17.03	7.16	24.65	18.15	7.23
	40	17.21	13.41	6.48	19.17	13.80	6.57	19.82	15.00	6.62	21.13	15.05	6.68	21.78	16.25	6.71	23.09	16.19	6.78	24.39	17.24	6.85
46	13.70	12.15	6.32	15.27	13.05	6.40	15.78	13.83	6.44	16.81	14.24	6.50	17.35	15.37	6.54	18.39	15.31	6.61	19.42	16.29	6.67	

■ Heating capacity (Double twin)

● Compact cassette type

Model: AUHG22LVLA × 4

AFR	m ³ /h	3,720
-----	-------------------	-------

		Indoor temperature											
		°CDB		16		18		20		22		24	
		°CDB	°CWB	TC	IP	TC	IP	TC	IP	TC	IP	TC	IP
Outdoor temperature			kW		kW		kW		kW		kW		
	-20	-21	12.77	6.49	12.47	6.62	12.16	6.76	11.86	6.89	11.56	7.02	
	-15	-16	19.57	7.49	19.11	7.64	18.64	7.80	18.18	7.95	17.72	8.11	
	-10	-11	22.81	7.95	22.27	8.12	21.73	8.28	21.19	8.45	20.65	8.61	
	-5	-7	25.33	8.29	24.73	8.47	24.12	8.64	23.52	8.81	22.92	8.98	
	0	-2	27.31	8.38	26.66	8.55	26.00	8.73	25.35	8.90	24.71	9.06	
	5	3	30.86	8.40	30.12	8.57	29.39	8.75	28.65	8.91	27.92	9.05	
	7	6	31.19	8.41	30.44	8.58	29.70	8.76	28.96	8.93	28.22	9.05	
	10	8	32.64	8.35	31.86	8.52	31.08	8.70	30.29	8.87	29.53	9.05	
	15	10	33.88	8.35	33.07	8.51	32.26	8.69	31.45	8.87	30.65	9.00	
	20	15	30.48	7.28	29.75	7.42	29.02	7.58	28.30	7.74	27.57	7.84	
24	18	31.16	7.25	30.42	7.39	29.67	7.54	28.93	7.70	28.20	7.80		

● Duct type

Model: ARHG22LMLA × 4

AFR	m ³ /h	4,400
-----	-------------------	-------

		Indoor temperature											
		°CDB		16		18		20		22		24	
		°CDB	°CWB	TC	IP	TC	IP	TC	IP	TC	IP	TC	IP
Outdoor temperature			kW		kW		kW		kW		kW		
	-20	-21	12.77	6.85	12.47	6.98	12.16	7.13	11.86	7.27	11.56	7.40	
	-15	-16	19.57	7.90	19.11	8.06	18.64	8.23	18.18	8.39	17.72	8.55	
	-10	-11	22.81	8.39	22.27	8.56	21.73	8.74	21.19	8.91	20.65	9.09	
	-5	-7	25.33	8.75	24.73	8.93	24.12	9.11	23.52	9.29	22.92	9.47	
	0	-2	27.31	8.84	26.66	9.02	26.00	9.21	25.35	9.39	24.71	9.56	
	5	3	30.86	8.86	30.12	9.04	29.39	9.23	28.65	9.40	27.92	9.54	
	7	6	31.19	8.87	30.44	9.05	29.70	9.24	28.96	9.42	28.22	9.55	
	10	8	32.64	8.81	31.86	8.98	31.08	9.18	30.29	9.35	29.53	9.55	
	15	10	33.88	8.81	33.07	8.98	32.26	9.17	31.45	9.36	30.65	9.49	
	20	15	30.48	7.68	29.75	7.83	29.02	8.00	28.30	8.17	27.57	8.27	
24	18	31.16	7.64	30.42	7.79	29.67	7.96	28.93	8.13	28.20	8.23		

● Floor/Ceiling type

Model: ABHG22LVTA × 4

AFR	m ³ /h	3,920
-----	-------------------	-------

		Indoor temperature											
		°CDB		16		18		20		22		24	
		°CDB	°CWB	TC	IP	TC	IP	TC	IP	TC	IP	TC	IP
Outdoor temperature			kW		kW		kW		kW		kW		
	-20	-21	12.77	6.49	12.47	6.62	12.16	6.76	11.86	6.89	11.56	7.02	
	-15	-16	19.57	7.49	19.11	7.64	18.64	7.80	18.18	7.95	17.72	8.11	
	-10	-11	22.81	7.95	22.27	8.12	21.73	8.28	21.19	8.45	20.65	8.61	
	-5	-7	25.33	8.29	24.73	8.47	24.12	8.64	23.52	8.81	22.92	8.98	
	0	-2	27.31	8.38	26.66	8.55	26.00	8.73	25.35	8.90	24.71	9.06	
	5	3	30.86	8.40	30.12	8.57	29.39	8.75	28.65	8.91	27.92	9.05	
	7	6	31.19	8.41	30.44	8.58	29.70	8.76	28.96	8.93	28.22	9.05	
	10	8	32.64	8.35	31.86	8.52	31.08	8.70	30.29	8.87	29.53	9.05	
	15	10	33.88	8.35	33.07	8.51	32.26	8.69	31.45	8.87	30.65	9.00	
	20	15	30.48	7.28	29.75	7.42	29.02	7.58	28.30	7.74	27.57	7.84	
24	18	31.16	7.25	30.42	7.39	29.67	7.54	28.93	7.70	28.20	7.80		

7. Capacity compensation rate for pipe length and height difference

OUTDOOR UNIT
AOHG72-90LRLA

OUTDOOR UNIT
AOHG72-90LRLA

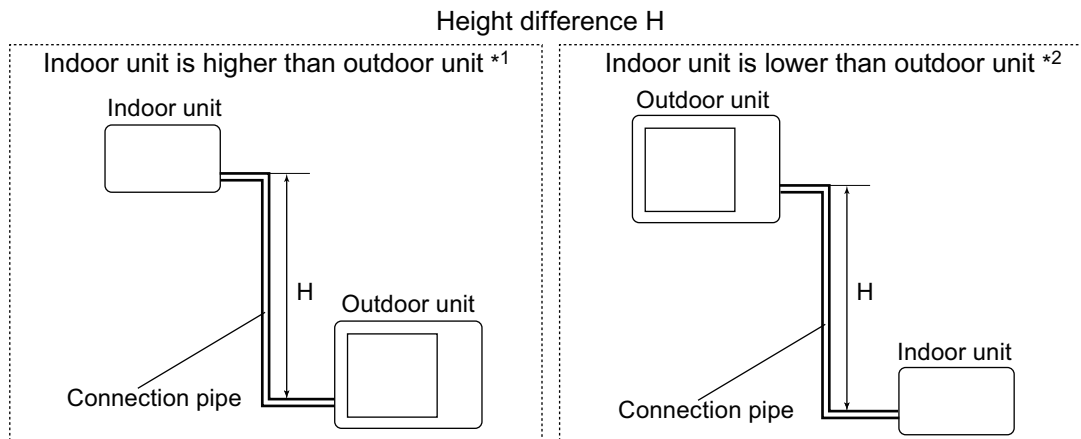

7-1. Model: AOHG72LRLA

NOTE: Values mentioned in the table are calculated based on the maximum capacity.

COOLING		Pipe length (m)												
		5	7.5	10	20	30	40	50	60	70	80	90	100	
Height difference H (m)	Indoor unit is higher than outdoor unit *1	30	—	—	—	—	0.898	0.874	0.850	0.826	0.803	0.780	0.756	0.732
		20	—	—	—	0.938	0.913	0.889	0.864	0.840	0.817	0.793	0.769	0.744
		10	—	—	0.978	0.953	0.928	0.903	0.879	0.854	0.830	0.806	0.781	0.757
		7.5	—	0.988	0.982	0.957	0.932	0.907	0.882	0.858	0.834	0.809	0.784	0.760
		5	0.992	0.992	0.986	0.961	0.935	0.911	0.886	0.861	0.837	0.812	0.788	0.763
	0	1.000	1.000	0.994	0.969	0.943	0.918	0.893	0.868	0.844	0.819	0.794	0.769	
	Indoor unit is lower than outdoor unit *2	-5	1.000	1.000	0.994	0.969	0.943	0.918	0.893	0.868	0.844	0.819	0.794	0.769
		-7.5	—	1.000	0.994	0.969	0.943	0.918	0.893	0.868	0.844	0.819	0.794	0.769
		-10	—	—	0.994	0.969	0.943	0.918	0.893	0.868	0.844	0.819	0.794	0.769
		-20	—	—	—	0.969	0.943	0.918	0.893	0.868	0.844	0.819	0.794	0.769
-30		—	—	—	—	0.943	0.918	0.893	0.868	0.844	0.819	0.794	0.769	

HEATING		Pipe length (m)												
		5	7.5	10	20	30	40	50	60	70	80	90	100	
Height difference H (m)	Indoor unit is higher than outdoor unit *1	30	—	—	—	—	0.977	0.966	0.956	0.946	0.938	0.928	0.918	0.908
		20	—	—	—	0.987	0.977	0.966	0.956	0.946	0.938	0.928	0.918	0.908
		10	—	—	0.997	0.987	0.977	0.966	0.956	0.946	0.938	0.928	0.918	0.908
		7.5	—	1.000	0.997	0.987	0.977	0.966	0.956	0.946	0.938	0.928	0.918	0.908
		5	1.000	1.000	0.997	0.987	0.977	0.966	0.956	0.946	0.938	0.928	0.918	0.908
	0	1.000	1.000	0.997	0.987	0.977	0.966	0.956	0.946	0.938	0.928	0.918	0.908	
	Indoor unit is lower than outdoor unit *2	-5	0.995	0.995	0.992	0.982	0.972	0.961	0.951	0.941	0.933	0.923	0.913	0.903
		-7.5	—	0.993	0.990	0.980	0.970	0.959	0.949	0.939	0.931	0.921	0.911	0.901
		-10	—	—	0.987	0.977	0.967	0.956	0.946	0.937	0.928	0.918	0.908	0.898
		-20	—	—	—	0.967	0.957	0.947	0.937	0.927	0.919	0.909	0.899	0.889
-30		—	—	—	—	0.948	0.937	0.927	0.918	0.909	0.900	0.890	0.880	

7-2. Model: AOHG90LRLA

NOTE: Values mentioned in the table are calculated based on the maximum capacity.

COOLING			Pipe length (m)											
			5	7.5	10	20	30	40	50	60	70	80	90	100
Height difference H (m)	Indoor unit is higher than outdoor unit *1	30	—	—	—	—	0.898	0.874	0.850	0.826	0.803	0.780	0.756	0.732
		20	—	—	—	0.938	0.913	0.889	0.864	0.840	0.817	0.793	0.769	0.744
		10	—	—	0.978	0.953	0.928	0.903	0.879	0.854	0.830	0.806	0.781	0.757
		7.5	—	0.988	0.982	0.957	0.932	0.907	0.882	0.858	0.834	0.809	0.784	0.760
		5	0.992	0.992	0.986	0.961	0.935	0.911	0.886	0.861	0.837	0.812	0.788	0.763
	0	1.000	1.000	0.994	0.969	0.943	0.918	0.893	0.868	0.844	0.819	0.794	0.769	
	Indoor unit is lower than outdoor unit *2	-5	1.000	1.000	0.994	0.969	0.943	0.918	0.893	0.868	0.844	0.819	0.794	0.769
		-7.5	—	1.000	0.994	0.969	0.943	0.918	0.893	0.868	0.844	0.819	0.794	0.769
		-10	—	—	0.994	0.969	0.943	0.918	0.893	0.868	0.844	0.819	0.794	0.769
		-20	—	—	—	0.969	0.943	0.918	0.893	0.868	0.844	0.819	0.794	0.769
-30		—	—	—	—	0.943	0.918	0.893	0.868	0.844	0.819	0.794	0.769	

HEATING			Pipe length (m)											
			5	7.5	10	20	30	40	50	60	70	80	90	100
Height difference H (m)	Indoor unit is higher than outdoor unit *1	30	—	—	—	—	0.977	0.966	0.956	0.946	0.938	0.928	0.918	0.908
		20	—	—	—	0.987	0.977	0.966	0.956	0.946	0.938	0.928	0.918	0.908
		10	—	—	0.997	0.987	0.977	0.966	0.956	0.946	0.938	0.928	0.918	0.908
		7.5	—	1.000	0.997	0.987	0.977	0.966	0.956	0.946	0.938	0.928	0.918	0.908
		5	1.000	1.000	0.997	0.987	0.977	0.966	0.956	0.946	0.938	0.928	0.918	0.908
	0	1.000	1.000	0.997	0.987	0.977	0.966	0.956	0.946	0.938	0.928	0.918	0.908	
	Indoor unit is lower than outdoor unit *2	-5	0.995	0.995	0.992	0.982	0.972	0.961	0.951	0.941	0.933	0.923	0.913	0.903
		-7.5	—	0.993	0.990	0.980	0.970	0.959	0.949	0.939	0.931	0.921	0.911	0.901
		-10	—	—	0.987	0.977	0.967	0.956	0.946	0.937	0.928	0.918	0.908	0.898
		-20	—	—	—	0.967	0.957	0.947	0.937	0.927	0.919	0.909	0.899	0.889
-30		—	—	—	—	0.948	0.937	0.927	0.918	0.909	0.900	0.890	0.880	

8. Airflow

8-1. Model: AOHG72LRLA

● Cooling

Airflow	
m ³ /h	8,400
l/s	2,334
CFM	4,944

● Heating

Airflow	
m ³ /h	8,400
l/s	2,334
CFM	4,944

8-2. Model: AOHG90LRLA

● Cooling

Airflow	
m ³ /h	8,400
l/s	2,334
CFM	4,944

● Heating

Airflow	
m ³ /h	9,000
l/s	2,500
CFM	5,297

9. Operation noise (sound pressure)

9-1. Noise level curve

Model: AOHG72LRLA

Cooling

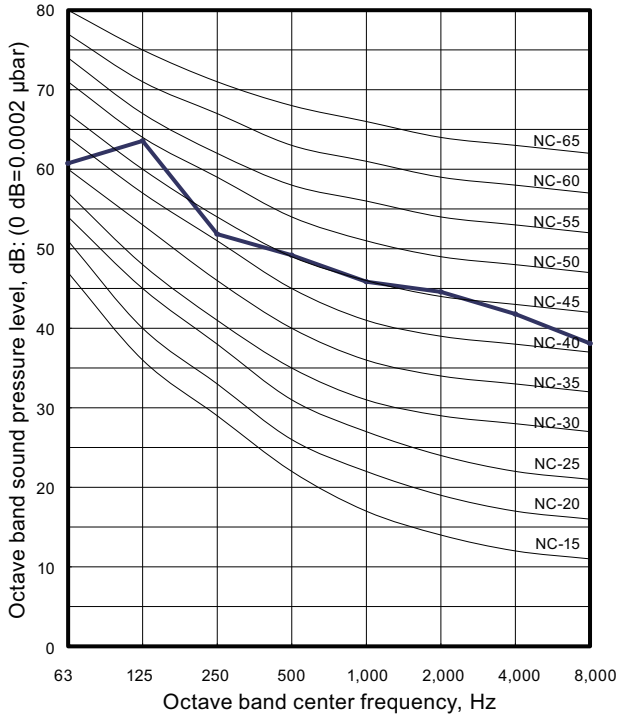

Heating

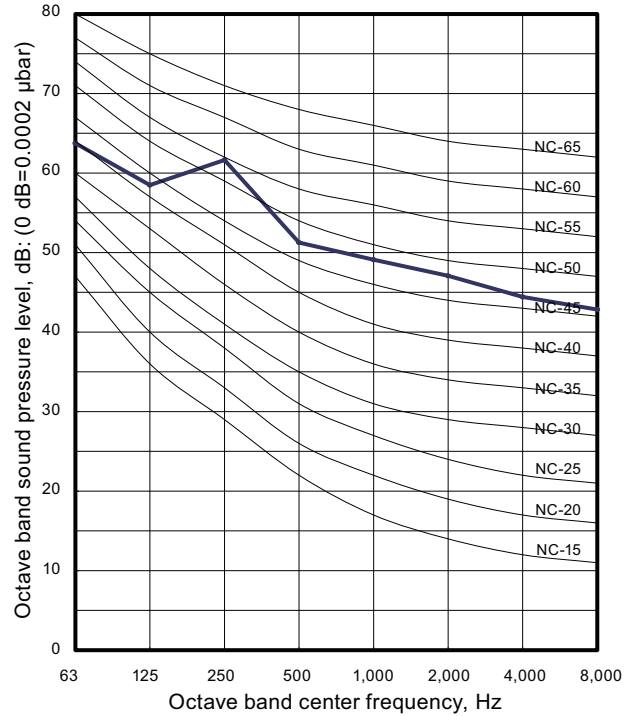

Model: AOHG90LRLA

Cooling

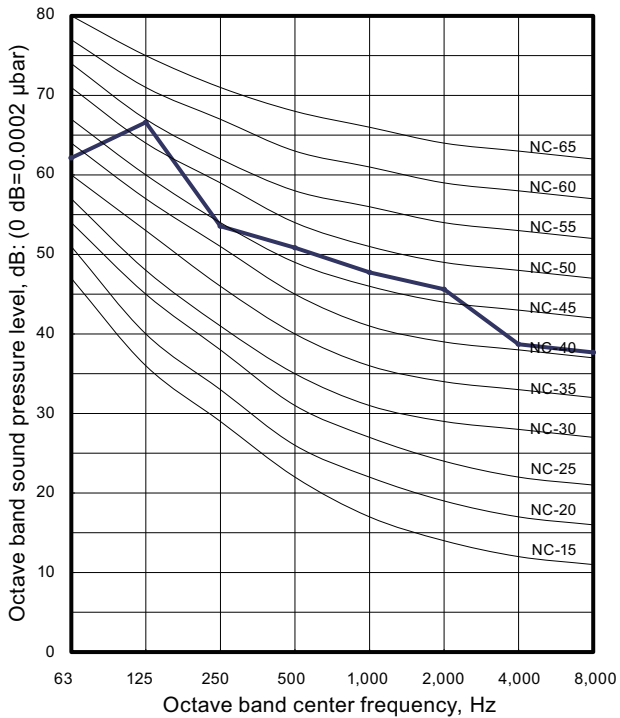

Heating

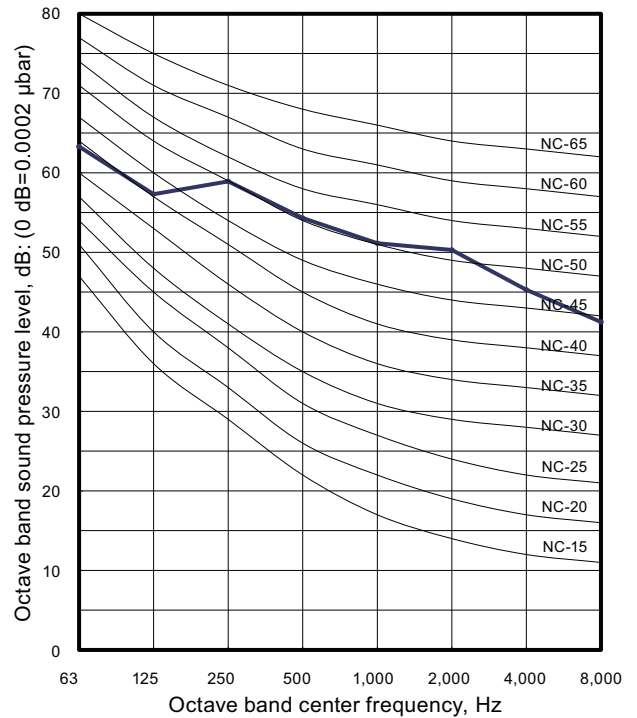

OUTDOOR UNIT
AOHG72-90LRLA

OUTDOOR UNIT
AOHG72-90LRLA

9-2. Sound level check point

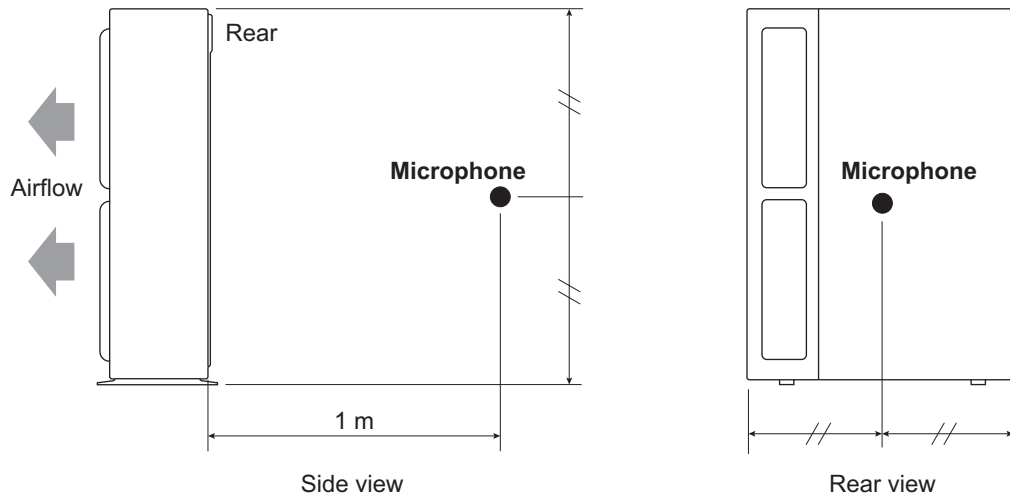

NOTE: Detailed shape of the actual outdoor unit might be slightly different from the one illustrated above.

10. Electrical characteristics

• AOHG72LRLA

Power supply	V	3N 400 ~
	Hz	50
Available voltage range	V	342—456

Indoor unit	MCA	MFA	Compressor	Outdoor fan motor	Indoor fan motor
			RLA	FLA	FLA
AUHG36LRLE × 2	13.2	30	10.6	1.2	0.7 × 2
AUHG24LVLA × 3	12.7				0.3 × 3
AUHG18LVLB × 4	12.6				0.2 × 4
ARHG36LMLE × 2	15.8				2.0 × 2
ARHG24LMLA × 3	13.9				0.7 × 3
ARHG18LLTB × 4	13.8				0.5 × 4
ABHG36LRTE × 2	13.2				0.7 × 2
ABHG24LVTA × 3	13.9				0.7 × 3
ABHG18LVTB × 4	13.8				0.5 × 4

• AOHG90LRLA

Power supply	V	3N 400 ~
	Hz	50
Available voltage range	V	342—456

Indoor unit	MCA	MFA	Compressor	Outdoor fan motor	Indoor fan motor
			RLA	FLA	FLA
AUHG45LRLA × 2	17.0	30	13.4	1.2	1.2 × 2
AUHG30LRLE × 3	16.7				0.7 × 3
AUHG22LVLA × 4	15.8				0.3 × 4
ARHG45LMLA × 2	18.8				2.1 × 2
ARHG30LMLE × 3	20.6				2.0 × 3
ARHG22LMLA × 4	17.4				0.7 × 4
ABHG45LRTE × 2	16.2				0.8 × 2
ABHG30LRTE × 3	16.7				0.7 × 3
ABHG22LVTA × 4	17.4				0.7 × 4

MCA: Minimum Circuit Amperes (A)

MFA: Maximum Fuse Amperes (A)







RLA: Rated Load Amperes (A)

FLA: Full Load Amperes (A)

11. Safety devices

Type of protection	Protection form		Model	
			AOHG72LRLA	AOHG90LRLA
Circuit protection	Current protector (Filter PCB)		500 V, 45 A × 3	
	Current fuse (Main PCB)		250 V, 10 A	
	Current fuse (Terminal)		250 V, 20 A	
Fan motor protection	Thermal protection program		Activate	115±15 °C Fan motor stop
			Reset	70 °C Fan motor restart
Compressor protection	Terminal protection program (Compressor temp.)		Activate	130 °C Compressor stop
			Reset	80 °C Compressor restart
	Thermal protection program (Discharge temp.)		Activate	115 °C Compressor stop
			Reset	After 7 minutes Compressor restart
High pressure protection	Pressure switch		Activate	4.2 ⁺⁰ _{-0.15} MPa Compressor stop
			Reset	3.2±0.15 MPa Compressor restart
	Pressure sensor		Activate	4.1 MPa Compressor stop
			Reset	After 3 minutes Compressor restart
Low pressure protection	Pressure sensor	Cooling	Activate	0.12 MPa or less (for 5 minutes) Compressor stop
			Reset	0.15 MPa Compressor restart

12. Accessories

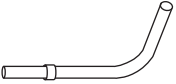
Part name	Exterior	Q'ty	Part name	Exterior	Q'ty
Installation manual		1	Joint pipe B		1
Drain pipe		1	Push mount cable tie		2
Drain cap		9	Grommet edging		2
Joint pipe A		1			

Part 3. SYSTEM DESIGN

1. Installation precautions

1-1. Indoor unit installation precautions

NOTE: The information listed below are general precautions.
Some models also include items that do not apply.

■ Places where prohibited for use

- Places where there is a danger of combustible gas leakage.
- Places where sulfur gas, chlorine gas, acid, alkali, or other matter which effects equipment is generated.
- Places where there is a lot of oil splash and steam such as kitchen or machinery room.
- Places where machinery which generates high frequencies is used.
- Ocean beaches and other areas where there is a lot of salt.
- Places where carbon fibers or any kind of powder suspended in the air.
- Inside of vehicles, ships, and other conveyances.
- Places where voltage fluctuations are large such as a factory.

■ Points to remember when installing

- The product shall be installed at a place which can withstand the weight and vibration of the indoor.
- To allow maintenance after refrigerant piping, drain piping, and electric wiring connection and installation, provide an installation service space and an inspection port, as required.
*Installation service space is shown on "[Dimensions](#)" on page 10.
- Be careful when installing the unit at the following places.

Condition	Contents	Countermeasures (Reference)
When the ceiling is high.	If the indoor unit is installed where the installation height given in the installation manual is exceeded, the temperature difference between the floor and ceiling of the room will be large and the heating effect will be poor. Moreover, even if the indoor unit is installed within the installation height, a similar phenomena will occur when installed in a room in which the doors are opened and closed frequently and hot air circulation is obstructed by furniture such as desks or chairs.	<ol style="list-style-type: none"> 1. Switch the setting to the high ceiling mode. 2. Install a circulator. 3. Arrange the furniture in the room so that it does not obstruct the hot air.
When lower level directly contacts the outside air.	When the lower level of the room is a semi-open space such as warehouse or parking lot the surface temperature of the flooring will become low and the radiation of cold from the floor will increase. In this case, even if the room temperature is suitable, you may feel the foot level is cold.	
When the airflow distribution is poor.	When an indoor unit is installed in a position where the outlet airflow will directly contact people, a draft may be felt. In addition, when there are obstructions in the path of the intake and outlet airflow, the air distribution may become extremely bad.	<ol style="list-style-type: none"> 1. Adjust the louver fins or take other measures matched to the site. 2. Change the indoor unit outlet.
When inside the ceiling is high temperature and high humidity.	When the indoor unit is installed where the inside of the ceiling is 30 °C RH80% or greater, the dew point temperature of the outer perimeter may become higher than the cabinet surface temperature and moisture will condense on the surface of the cabinet and water drops may fall inside the room. (" Figure 1-1 Moist air curve ") In addition, the humidity may vary considerably the same as when the inside of the ceiling is close to hermetically sealed and used as the outside air intake path.	<ol style="list-style-type: none"> 1. Add heat insulating material to the outside of the indoor unit cabinet. *Regarding the cassette type, use of optional High humidity correspondence kit is recommended. 2. Strengthen the heat insulating material of the refrigerant piping and drain piping too. ("Figure 1-2 Work method when reinforcing the heat insulation of on-site piping") 3. When the humidity inside the ceiling changes considerably, install a ventilation port.
When using an external duct.	When using an external duct to take in new fresh air, etc., condensation may form on the surface of the duct due to the effect of the outside air temperature and the humidity inside the ceiling.	Always perform heat insulation processing. (Heat insulating material: Glass wool 25 mm thick or more.)
When the remote controller installation site is bad.	If the cold or warm air blown out from the air conditioner directly contacts the thermostat section of the remote controller, the outlet temperature of the air conditioner may be sensed and room temperature control will be different from the room temperature, and "not cooled" or "not heated" or other trouble may occur. In addition, there is the possibility that the same kind of trouble may also occur when the remote controller is effected by direct sunlight.	<ol style="list-style-type: none"> 1. Install the remote controller where it will not be directly exposed to the cold or hot air. 2. Install the remote controller where it will not be directly exposed to sunlight or strong lighting.

Condition	Contents	Countermeasures (Reference)
When installation environment is quiet.	When the wall mounted type was installed in a bedroom, living room, or other quiet place, the sound of the refrigerant flow may be sensed as noise and must be taken into account.	<ol style="list-style-type: none"> 1. Plan installation of a model with external expansion valve. 2. Plan installation of a branch box farther from indoor unit. 3. Plan installation using another air conditioner.
When installing duct type in ceiling chamber system.	<p>In the case of the ceiling chamber system (duct is not installed at indoor unit inlet side and room air is sucked into the indoor unit through the inside of the ceiling), the thermistor inside the indoor unit may not correctly detect the room temperature.</p> <ul style="list-style-type: none"> • Heating operation: Room is not heated because the indoor unit is easily turned off by the thermostat. • Cooling operation: Room is too cold because the indoor unit is difficult to turn off by the thermostat. 	Replace the indoor unit thermistor with optional Remote sensor unit, and install the sensor where the room temperature can be correctly detected.
When the outlet air is sucked in at duct type.	Cooling operation does not cool the room and heating operation does not heat the room because the short circuited indoor unit is not turned on by the thermostat.	<ol style="list-style-type: none"> 1. Reconsider the ventilation port construction. 2. Replace the indoor unit thermistor with optional Remote sensor unit, and install the sensor where the room temperature can be correctly detected.
When using the wireless remote controller.	Signals may not be received when using it in a room illuminated by an inverter fluorescent lamp.	Turn on the fluorescent lamp and check if the indoor unit receives the signals from the remote controller. If the indoor unit does not receive the signals, consult an authorized service personnel.
When installing the inverter type.	It may generate noise in TV sets, stereos and PCs.	The inverter type should be installed at a sufficient distance from these equipments.

SYSTEM DESIGN

SYSTEM DESIGN

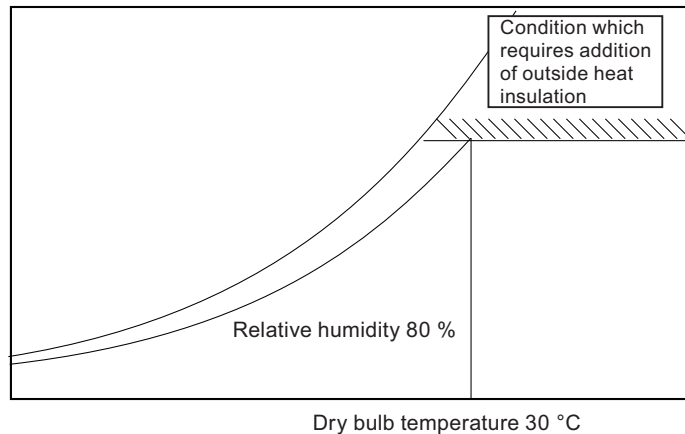

Figure 1-1 Moist air curve

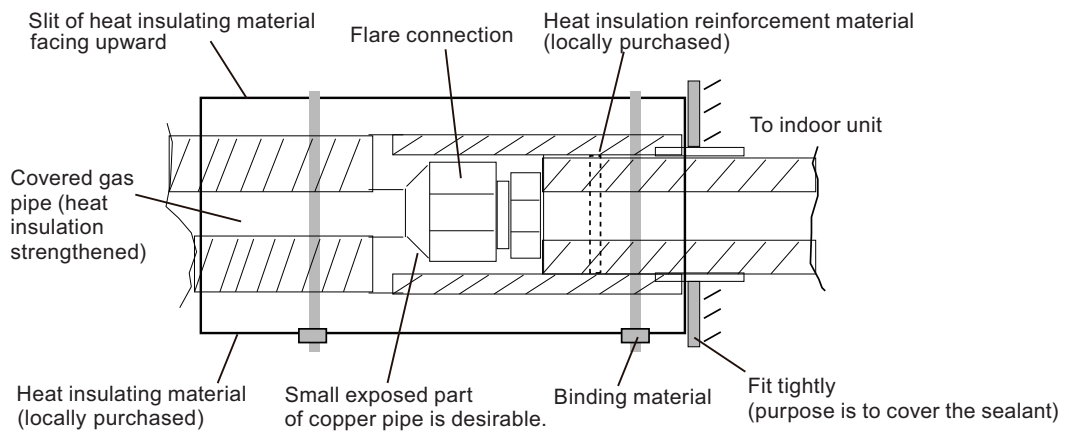

Figure 1-2 Work method when reinforcing the heat insulation of on-site piping

1-2. Outdoor unit installation precautions

NOTE: The information listed below are general precautions.

Some models also include items that do not apply.

■ Places where prohibited for use

- Places where there is a danger of combustible gas leakage.
- Places where sulfur gas, chlorine gas, acid, alkali, or other matter which effects equipment is generated.
- Places affected by heat radiation from other heat sources.
- Places where the air is stagnant.
- Places where machinery which generates high frequencies is used.
- Ocean beaches and other areas where there is a lot of salt.
- Inside of vehicles, ships, and other conveyances.
- Places where voltage fluctuations are large such as a factory.

■ Points to remember when installing

- The product shall be installed at a place which can withstand the weight and vibration of the outdoor unit.
- To allow maintenance after refrigerant piping, drain piping, and electric wiring connection and installation, provide an installation service space.
*Installation service space is shown in "[Installation space](#)" on page 146.
- Be careful when installing the set at the following places.

Condition	Contents	Countermeasures (Reference)
When installed near adjacent houses.	Perform installation work so that operating sound does not disturb the neighbors.	<ol style="list-style-type: none"> 1. Install a soundproof barrier. 2. Change the installation site.
When there is the possibility of strong wind.	<ul style="list-style-type: none"> • If the outdoor unit is exposed to strong wind, capacity may drop, frost may form during heating, and operation may be stopped by high pressure rise. In addition, when a very strong wind blows, the fan may be damaged. • When a very strong wind blows, there is the possibility of the outdoor unit being toppled over if held only by foundation bolts. 	<ol style="list-style-type: none"> 1. Install the outdoor unit with keeping a sufficient distance between the outlet side of the unit and a facing wall or fence. 2. Make the outlet direction and wind direction perpendicular. 3. Fasten the outdoor unit using toppling prevention hardware (purchased locally).
When snow accumulates.	If the outdoor unit is covered by accumulated snow, it may not be able to operate.	<ol style="list-style-type: none"> 1. Make the foundation as high as possible. 2. Perform snow prevention work.
When installing the inverter type.	It may generate noise in TV sets, stereos and PCs.	The inverter type should be installed at a sufficient distance from these equipments.

2. Pipe design

2-1. Important items when using refrigerant (R410A)

- **Refrigerant piping material and wall thickness**

It is necessary to use seamless copper tubes for refrigerant use. Thickness of tubes are shown in table below.

Nominal diameter	in	1/4	3/8	1/2	5/8	3/4	7/8	1-1/8	
Outside diameter	mm	6.35	9.52	12.70	15.88	19.05	22.22	28.58	
Material		JIS H3300 C1220T-O or equivalent* ¹					JIS H3300 C1220T-H or equivalent* ²		
Wall thickness* ³	mm	0.8			1.0	1.2	1.0		

*1: Allowable tensile stress $\geq 33 \text{ N/mm}^2$

*2: Allowable tensile stress $\geq 61 \text{ N/mm}^2$

*3: Endurance pressure of the pipes: 4.2 MPa

Select the pipe size in accordance with local rules.

- **Lubricant**

Refrigerant	R410A (Mixed refrigerant)
Lubricant	Synthetic oil

- **Tools**

R410A work requires a number of special tools. Since the tools (with * symbol) for R22 work cannot be used for R410A, prepare them beforehand.

Tool name	Process and application	
Pipe cutter	Pipe cutting	Refrigerant piping work
Flaring tool*	Pipe flaring work	
Torque wrench*	Flare nut connection	
Expander	Expansion at pipe connection	
Pipe bender	Pipe bending work	
Nitrogen gas	Pipe interior oxidation prevention	Air tightness test
Welder	Pipe brazing	Air tightness test ~ Refrigerant additional charging
Gauge manifold*	Vacuum evacuation and refrigerant charging operation check	
Charging hose*		
Vacuum pump (with adapter)*		Vacuum drying
Electronic scale for refrigerant charging		Refrigerant additional charging
Gas leak tester*	Gas leakage test	

*: For details, refer to the service manual.

2-2. Piping limitation

⚠ CAUTION

Keep the “piping limitation” for correct operation.

- **Allowable height difference:**

- If the height difference between indoor unit and outdoor unit is larger than the allowable value:

The pressure loss will be larger	→	Insufficient cooling and heating
The refrigerant in liquid pipe will flush	→	Refrigerant flow noise generate at indoor unit
The refrigerant oil will not return	→	Insufficient refrigerant oil resulting in compressor damage

- If the height difference between indoor units is larger than the allowable value:

The refrigerant flow balance will be poor	→	Insufficient cooling and heating (poor balance)
Refrigerant oil will collect in the piping or non-operating indoor units	→	Insufficient refrigerant oil resulting in compressor damage

- **Piping length:**

If the piping length is longer than prescribed:

The pressure loss will be larger	→	Insufficient cooling and heating
Too much refrigerant will be charged	→	Liquid backs up resulting in compressor damage
The refrigerant oil will not return	→	Insufficient refrigerant oil resulting in compressor damage

- **Pipe size:**

- If the pipe size is larger than designated size:

The refrigerant flow velocity will drop. Refrigerant oil will not return to the outdoor unit.	→	Insufficient refrigerant oil resulting in compressor damage
---	---	---

The refrigerant in liquid pipe will flush easily	→	Insufficient cooling and heating
--	---	----------------------------------

- If the pipe size is smaller than designated size:

The refrigerant circulation volume will drop	→	Insufficient cooling and heating
The pressure loss will be larger	→	Insufficient cooling and heating

- Twin type

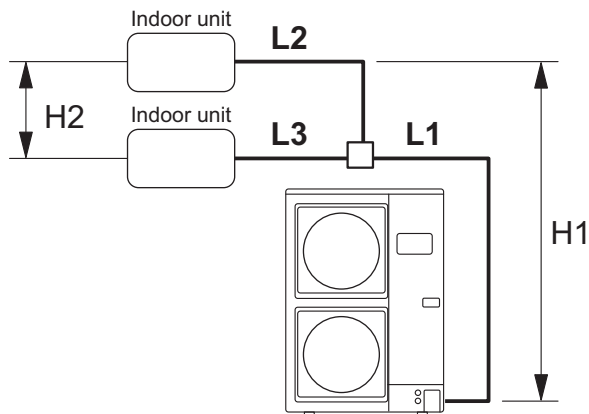

NOTE: Be certain to install indoor units in the same room because the combinations are for simultaneous operation. The lengths after branching should be equal if possible.

Model name (Outdoor unit)			AOHG72LRLA	AOHG90LRLA
Model name (Indoor unit)			36 kBtu/h × 2	45 kBtu/h × 2
Main pipe diameter (L1) (Standard)	Liquid	mm (in)	12.70 (1/2)	
	Gas		25.40 (1)	
Branch pipe diameter (L2, L3) (Standard)	Liquid	mm (in)	9.52 (3/8)	
	Gas		15.88 (5/8)	
Maximum piping length (L1 + L2 + L3)		m	100*	
Minimum piping length (L1 + L2 + L3)		m	5	
Maximum branch piping length (L2, L3)		m	20	
Maximum difference between branch lengths (L2 to L3)		m	8	
Maximum height difference (H1) (Indoor unit to outdoor unit)		m	30	
Maximum height difference (H2) (Indoor unit to outdoor unit)		m	0.5	

*: For the standard pipe diameter

Calculation of limitation

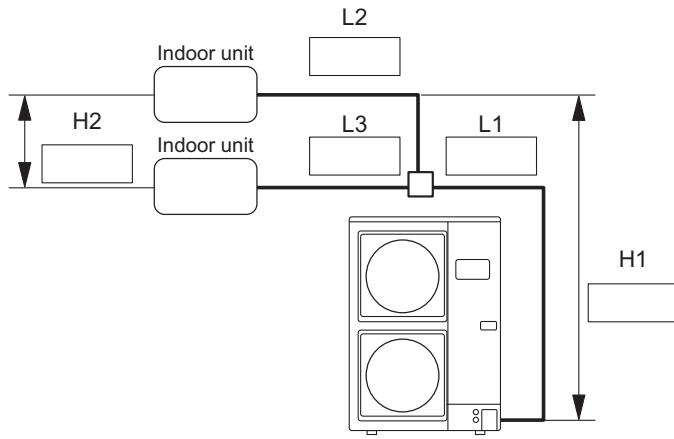

Pipe length

$$\begin{array}{ccccccc}
 & L1 & & L2 & & L3 & & \text{Total} \\
 \square & + & \square & + & \square & = & \square \\
 & & & & & & & 5 \text{ m or more and} \\
 & & & & & & & \text{max. piping length or less}
 \end{array}$$

$$\begin{array}{ccc}
 L1 & + & L2 & = & \text{Total} \\
 \square & + & \square & = & \square \\
 & & & & \text{Max. piping length or less}
 \end{array}$$

$$\begin{array}{ccc}
 L1 & + & L3 & = & \text{Total} \\
 \square & + & \square & = & \square \\
 & & & & \text{Max. piping length or less}
 \end{array}$$

$$\begin{array}{ccc}
 L2 & - & L3 & = & \text{Total} \\
 \square & - & \square & = & \square \\
 & & & & 8 \text{ m or less}
 \end{array}$$

$$\begin{array}{cc}
 L2 & L3 \\
 \square & \square \\
 20 \text{ m or less} & 20 \text{ m or less}
 \end{array}$$

Height difference

$$\begin{array}{c}
 H1 \\
 \square \\
 30 \text{ m or less}
 \end{array}$$

$$\begin{array}{c}
 H2 \\
 \square \\
 0.5 \text{ m or less}
 \end{array}$$

- Triple type

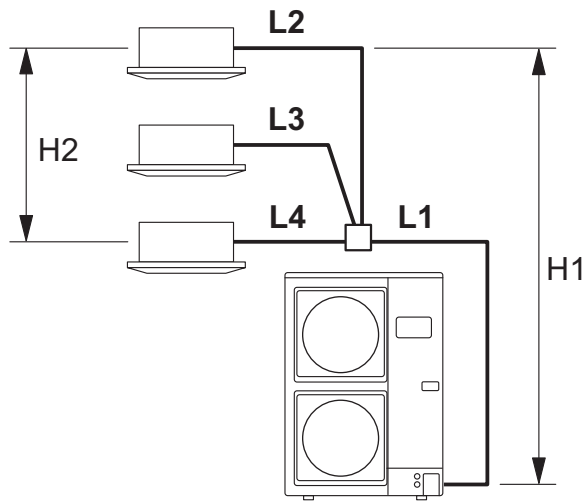

NOTE: Be certain to install indoor units in the same room because the combinations are for simultaneous operation. The lengths after branching should be equal if possible.

Model name (Outdoor unit)			AOHG72LRLA	AOHG90LRLA
Model name (Indoor unit)			24 kBtu/h × 3	30 kBtu/h × 3
Main pipe diameter (L1) (Standard)	Liquid	mm (in)	12.70 (1/2)	
	Gas		25.40 (1)	
Branch pipe diameter (L2, L3, L4) (Standard)	Liquid	mm (in)	9.52 (3/8)	
	Gas		15.88 (5/8)	
Maximum piping length (L1 + L2 + L3 + L4)		m	100*	
Minimum piping length (L1 + L2 + L3 + L4)		m	5	
Maximum branch piping length (L2, L3, L4)		m	20	
Maximum difference between branch lengths (L2, L3, L4)		m	8	
Maximum height difference (H1) (Indoor unit to outdoor unit)		m	30	
Maximum height difference (H2) (Indoor unit to outdoor unit)		m	0.5	

*: For the standard pipe diameter

Calculation of limitation

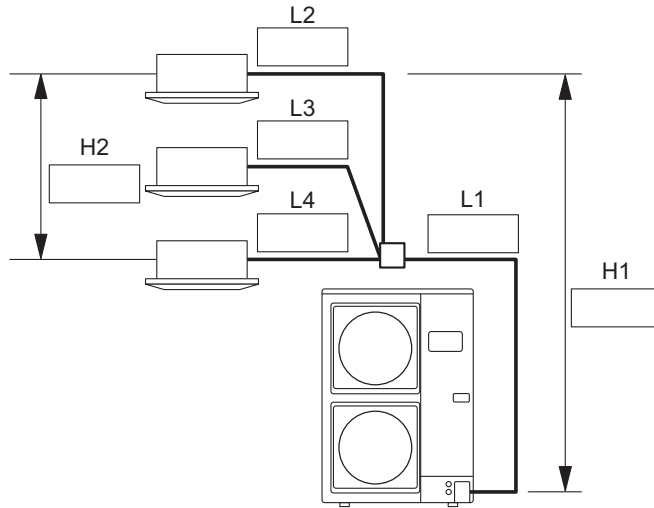

Pipe length

$$L1 + L2 + L3 + L4 = \text{Total}$$

5 m or more and 100 m or less

$$L1 + L2 = \text{Total}$$

100 m or less

$$L1 + L3 = \text{Total}$$

100 m or less

$$L1 + L4 = \text{Total}$$

100 m or less

$$L2 - L3 = \text{Total}$$

8 m or less

$$L2 - L4 = \text{Total}$$

8 m or less

$$L3 - L4 = \text{Total}$$

8 m or less

L2	L3	L4
□	□	□
20 m or less	20 m or less	20 m or less

Height difference

$$H1$$

□

30 m or less

$$H2$$

□

0.5 m or less

• Double twin type

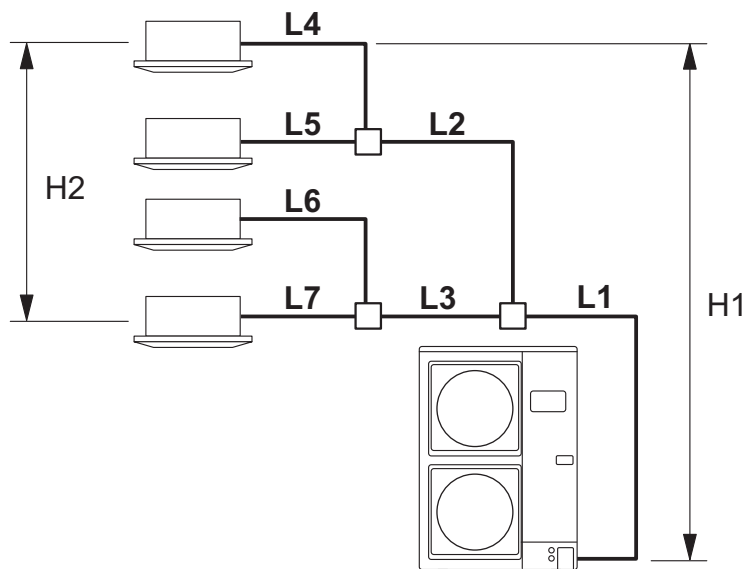

NOTE: Be certain to install indoor units in the same room because the combinations are for simultaneous operation. The lengths after branching should be equal if possible.

Model name (Outdoor unit)			AOHG72LRLA	AOHG90LRLA
Model name (Indoor unit)			18 kBtu/h × 4	22 kBtu/h × 4
Main pipe diameter (L1) (Standard)	Liquid	mm (in)	12.70 (1/2)	
	Gas		25.40 (1)	
Branch pipe diameter of the first separation tube, Main pipe diameter of the second separation tube (L2, L3) (Standard)	Liquid	mm (in)	9.52 (3/8)	
	Gas		15.88 (5/8)	
Branch pipe diameter of the second separation tube (L4, L5, L6, L7) (Standard)	Liquid	mm (in)	6.35 (1/4)	9.52 (3/8)
	Gas		12.70 (1/2)	15.88 (5/8)
Maximum piping length (L1 + L2 + L3 + L4 + L5 + L6 + L7)		m	100*	
Minimum piping length (L1 + L2 + L3 + L4 + L5 + L6 + L7)		m	5	
Maximum branch piping length (L2 + L4, L2 + L5, L3 + L6, L3 + L7)		m	20	
Maximum difference between branch lengths • L2 and L3 • L4 and L5 • L6 and L7 • L2 + L4, L2 + L5, L3 + L6, L3 + L7		m	8	
Maximum height difference (H1) (Indoor unit to outdoor unit)		m	30	
Maximum height difference (H2) (Indoor unit to outdoor unit)		m	0.5	

*: For the standard pipe diameter

Calculation of limitation

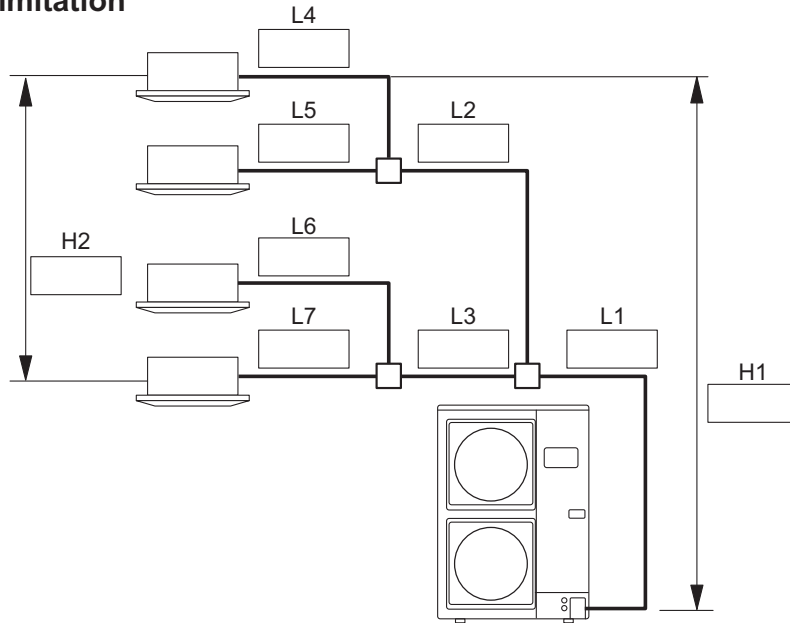

Pipe length

$$L1 + L2 + L3 + L4 + L5 + L6 + L7 = \text{Total}$$

5 m or more and 100 m or less

$$L1 + L2 + L4 \text{ or } L5 = \text{Total}$$

100 m or less

$$L1 + L3 + L6 \text{ or } L7 = \text{Total}$$

100 m or less

$$L2 + L4 - L2 + L5 = \text{Total}$$

8 m or less

$$L2 + L4 - L3 + L6 = \text{Total}$$

8 m or less

$$L2 + L4 - L3 + L7 = \text{Total}$$

8 m or less

$$L2 + L5 - L3 + L6 = \text{Total}$$

8 m or less

$$L2 + L5 - L3 + L7 = \text{Total}$$

8 m or less

$$L3 + L6 - L3 + L7 = \text{Total}$$

8 m or less

$$L2 + L4 = \text{Total}$$

20 m or less

$$L2 + L5 = \text{Total}$$

20 m or less

$$L3 + L5 = \text{Total}$$

20 m or less

$$L3 + L6 = \text{Total}$$

20 m or less

$$L2 - L3 = \text{Total}$$

8 m or less

$$L4 - L5 = \text{Total}$$

8 m or less

$$L6 - L7 = \text{Total}$$

8 m or less

Height difference

$$H1$$

30 m or less

$$H2$$

0.5 m or less

2-3. Pipe size

■ Pipe size selection

- Twin type

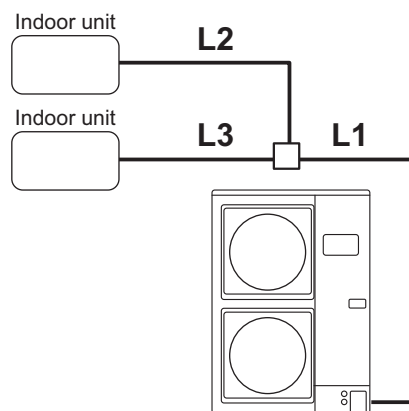

Model name (Outdoor unit)			AOHG72LRLA and AOHG90LRLA	
			Size down	Standard
Main pipe diameter (L1)	Liquid	mm (in)	12.70 (1/2)	
	Gas		22.22 (7/8)*	25.40 (1)
Branch pipe diameter (L2, L3)	Liquid	mm (in)	9.52 (3/8)	
	Gas		15.88 (5/8)	
Maximum piping length (L1 + L2 + L3)		m	100	
Pre-charge length		m	30	

*: Use the reducer attached with the product.

- Triple type

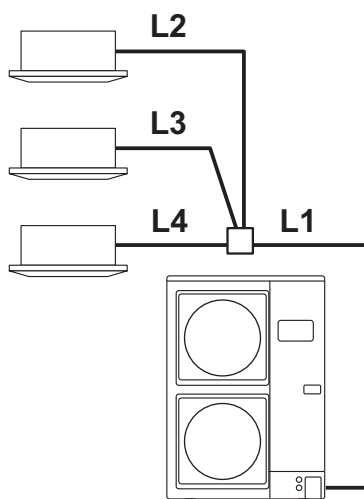

Model name (Outdoor unit)			AOHG72LRLA and AOHG90LRLA	
			Size down	Standard
Main pipe diameter (L1)	Liquid	mm (in)	12.70 (1/2)	
	Gas		22.22 (7/8)*	25.40 (1)
Branch pipe diameter (L2, L3, L4)	Liquid	mm (in)	9.52 (3/8)	
	Gas		15.88 (5/8)	
Maximum piping length (L1 + L2 + L3 + L4)		m	100	
Pre-charge length		m	30	

*: Use the reducer attached with the product.

- Double twin type

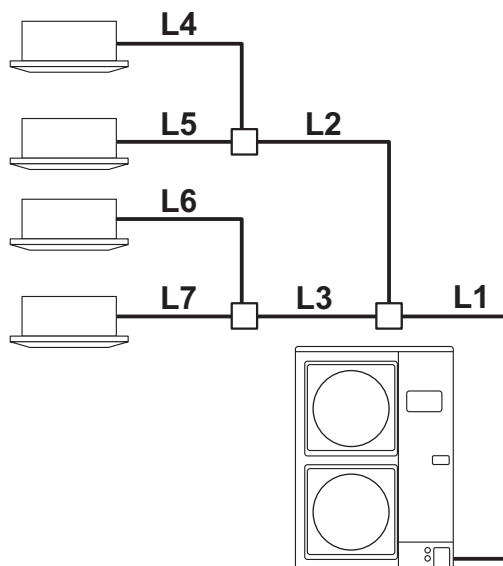

Model name (Outdoor unit)			AOHG72LRLA		AOHG90LRLA	
			Size down	Standard	Size down	Standard
Main pipe diameter (First separation) (L1)	Liquid	mm (in)	12.70 (1/2)			
	Gas		22.22 (7/8)*	25.40 (1)	22.22 (7/8)*	25.40 (1)
Branch pipe diameter (First separation) (L2, L3)	Liquid	mm (in)	9.52 (3/8)			
	Gas		15.88 (5/8)			
Branch pipe diameter (Second separation) (L4, L5, L6, L7)	Liquid	mm (in)	6.35 (1/4)		9.52 (3/8)	
	Gas		12.70 (1/2)		15.88 (5/8)	
Maximum piping length (L1 + L2 + L3 + L4 + L5 + L6 + L7)		m	100			
Pre-charge length		m	30			

*: Use the reducer attached with the product.

■ Branch pipes (Optional parts)

Model name (Outdoor unit)	Connection type	Number of indoor units	Kit name	
			First branch	Second branch
AOHG72LRLA	Twin	2	UTP-SX272A	—
	Triple	3	UTP-SX372A	—
	Double twin	4	UTP-SX272A	UTP-SX236A
AOHG90LRLA	Twin	2	UTP-SX272A	—
	Triple	3	UTP-SX372A	—
	Double twin	4	UTP-SX272A	UTP-SX254A

2-4. Selection of pipe heat insulating material

Always insulate the refrigerant pipe to prevent condensation and water droplets by the refrigerant pipe. For selection of pipe heat insulating material, refer to following items.

- Decide the thickness of the heat insulating material by referring to the recommended minimum thickness in Table 1. (For installation condition T=32 °CDB, humidity≤70%, humidity≤75%, humidity≤80%, humidity≤85%)

Table 2-1 Size of refrigerant pipe and recommended minimum thickness of heat insulating material (In case a heat insulating material which thermal conductivity is equal to or less than 0.040 W/mk is used.)

		Recommended minimum thickness for heat insulating material (mm)			
		≤70%	≤75%	≤80%	≤85%
Relative humidity		≤70%	≤75%	≤80%	≤85%
Refrigerant pipe outside diameter (mm [in])	6.35 (1/4)	8	10	13	17
	9.52 (3/8)	9	11	14	18
	12.70 (1/2)	10	12	15	19
	15.88 (5/8)	10	12	16	20
	19.05 (3/4)	10	13	16	21
	22.22 (7/8)	11	13	17	22
	25.40 (1)	11	13	17	22

- When the outdoor unit is installed in a higher position than the indoor unit, fill the connecting part gap with putty, etc. to prevent the dew condensation water of the valve of the outdoor unit from flowing to the indoors from the gap between the pipe and the heat insulating material.
- Liquid pipe and gas pipe should be completely insulated with same specification.
- In case not to insulate and not to seal refrigerant pipe completely, it will become the cause of water leak.
- When an ambient temperature and relative humidity exceed 32 °CDB and 85% respectively, strengthen heat insulation of refrigerant pipe. If necessary put a heat insulation on indoor unit casing. When not strengthening heat insulation of refrigerant pipe, the surface of the heat insulation may be dewed.
- Since gas pipe becomes high temperature at heating operation for heat pump type, select the heat insulating material which heat-resistant temperature is 120 °CDB or more.
- Make sure that pipe is covered completely by the heat insulation, not exposing to air. Inadequate heat insulation may cause condensation.
- Do not cover heat insulation gas and liquid pipes together as figure below. It may cause condensation and capacity drop by heat loss.

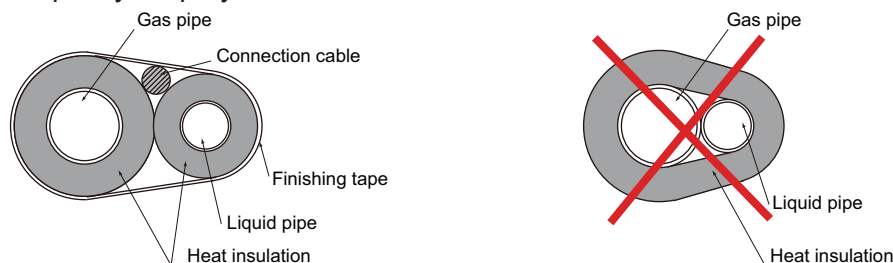

2-5. Additional charge calculation

⚠ CAUTION

- Do not turn on the power unless all operations are complete.
- After evacuating the system, add refrigerant.
- Do not charge the system with a refrigerant other than R410A.
- Always keep to the limit on the total amount of refrigerant. Exceeding the limit on the total amount of refrigerant will lead to malfunction during charging of refrigerant.
- Do not reuse recovered refrigerant.
- When charging the refrigerant, take into account the slight change in the composition of the gas and liquid phases, and always charge from the liquid phase side whose composition is stable. Adding refrigerant through the gas pipe will cause a malfunction.
- Check if the steel cylinder has a siphon installed or not before filling. (There is an indication “with siphon for filling liquid” on steel cylinder.)

Filling method for cylinder with siphon

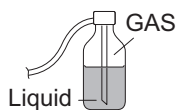

Set the cylinder vertical and fill with the liquid.
(Liquid can be filled without turning bottom up with the siphon inside.)

Filling method for other cylinders

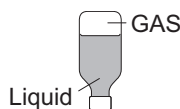

Turn bottom up and fill with the liquid.
(Be careful to avoid turning over the cylinder.)

- Be sure to use the special tools for R410A for pressure resistance and to avoid mixing of impure substances.
- If the units are further apart than the maximum pipe length, correct operation cannot be guaranteed.
- Make sure to back closing valve after refrigerant charging. Otherwise, the compressor may fail.
- Minimize refrigerant release to the air. Excessive release is prohibited under the Freon collection and destruction law.

■ If additional refrigerant is required

When the piping is longer than pre-charge length, additional charging is necessary.

1. Remove the charging cap from the liquid pipe.
2. Attach a charging pipe hose to the refrigerant cylinder, and connect it to the charging port.
3. Add refrigerant by calculating the additional refrigerant volume in accordance with the table below.
4. Remove the charging hose and install the charging cap.
5. Remove the body caps (gas pipe and liquid pipe), and open the valves.
6. Close the body caps.

NOTES:

- Tighten the body caps and charging caps to the torques values specified in the following table.

Blank cap (mm [in])	Tightening torque (N•m [kgf•cm])
6.35 (1/4)	20 to 25 (200 to 250)
9.52 (3/8)	20 to 25 (200 to 250)
12.70 (1/2)	28 to 32 (280 to 320)
15.88 (5/8)	30 to 35 (300 to 350)
19.05 (3/4)	35 to 40 (350 to 400)

- To open and close the valves,
 - Use an M5 hexagon wrench for liquid pipes.
 - Use an M10 hexagon wrench for gas pipes.

● Pre-charge length

Piping length (L1) pre-charge (m)
30

● Additional charging amount for Twin type

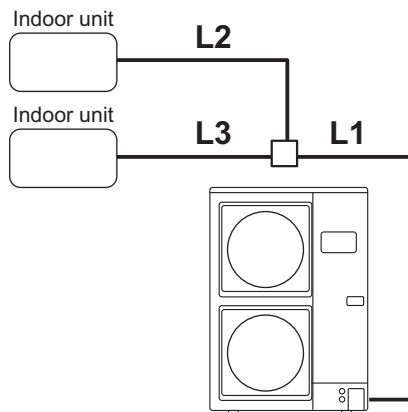

Pre-charge length $L1 + L2 + L3$

The additional charging amount will be calculated as follows.

- A: Piping length (m) of liquid pipe with outside diameter of 12.70 mm (1/2 in)
- B: Piping length (m) of liquid pipe with outside diameter of 9.52 mm (3/8 in)
- C: Piping length (m) of liquid pipe with outside diameter of 6.35 mm (1/4 in)
- Additional charging amount (g) = $(A \times 110) + (B \times 50) + (C \times 30) - 3,300$

NOTE: Do not remove refrigerant, even if the additional amount calculated is negative.

Example:

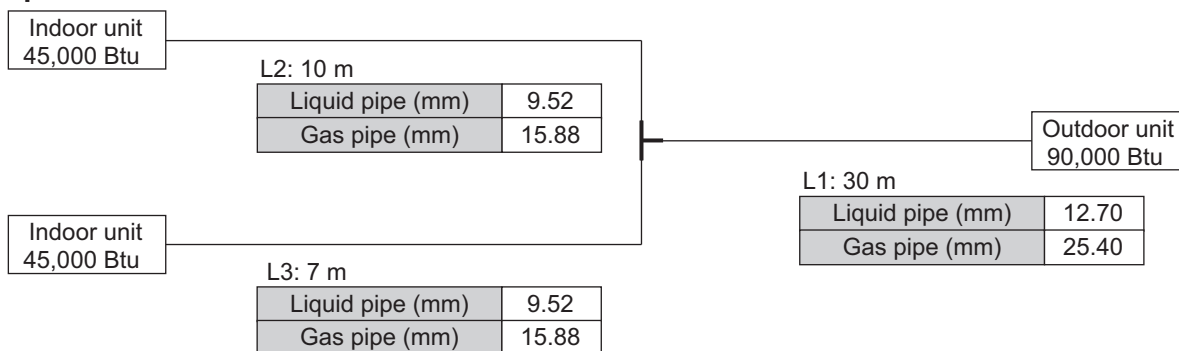

Liquid pipe diameter (mm)	Piping length (m)	Coefficient
12.70	30	A = 30
9.52	17	B = 17
6.35	0	C = 0

Applying the formula,

$$(30 \times 110) + (17 \times 50) + (0 \times 30) - 3,300 = 850$$

The additional charging amount is 850 g.

● Additional charging amount for Triple type

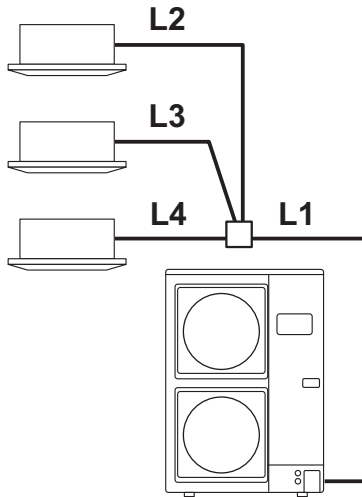

Pre-charge length $L1 + L2 + L3 + L4$

The additional charging amount will be calculated as follows.

- A: Piping length (m) of liquid pipe with outside diameter of 12.70 mm (1/2 in)
- B: Piping length (m) of liquid pipe with outside diameter of 9.52 mm (3/8 in)
- C: Piping length (m) of liquid pipe with outside diameter of 6.35 mm (1/4 in)
- Additional charging amount (g) = $(A \times 110) + (B \times 50) + (C \times 30) - 3,300$

NOTE: Do not remove refrigerant, even if the additional amount calculated is negative.

Example:

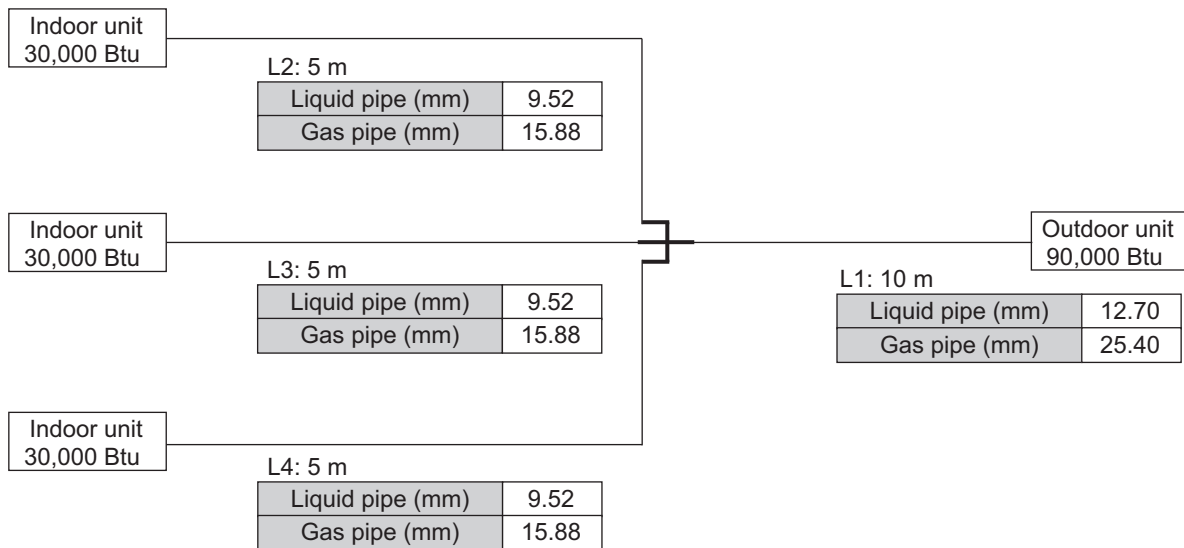

Liquid pipe diameter (mm)	Piping length (m)	Coefficient
12.70	10	A = 10
9.52	15	B = 15
6.35	0	C = 0

Applying the formula,

$$(10 \times 110) + (15 \times 50) + (0 \times 30) - 3,300 = -1,450$$

The calculated value is negative. Do not add or remove any refrigerant.

● Additional charging amount for Double twin type

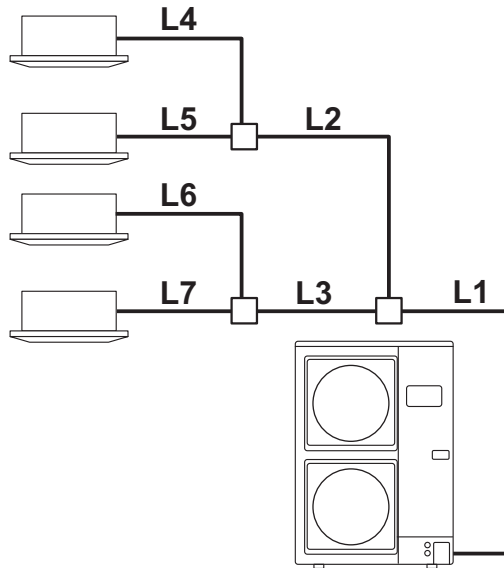

Pre-charge length $L1 + L2 + L3 + L4 + L5 + L6 + L7$

The additional charging amount will be calculated as follows.

- A: Piping length (m) of liquid pipe with outside diameter of 12.70 mm (1/2 in)
- B: Piping length (m) of liquid pipe with outside diameter of 9.52 mm (3/8 in)
- C: Piping length (m) of liquid pipe with outside diameter of 6.35 mm (1/4 in)
- Additional charging amount (g) = $(A \times 110) + (B \times 50) + (C \times 30) - 3,300$

NOTE: Do not remove refrigerant, even if the additional amount calculated is negative.

Example:

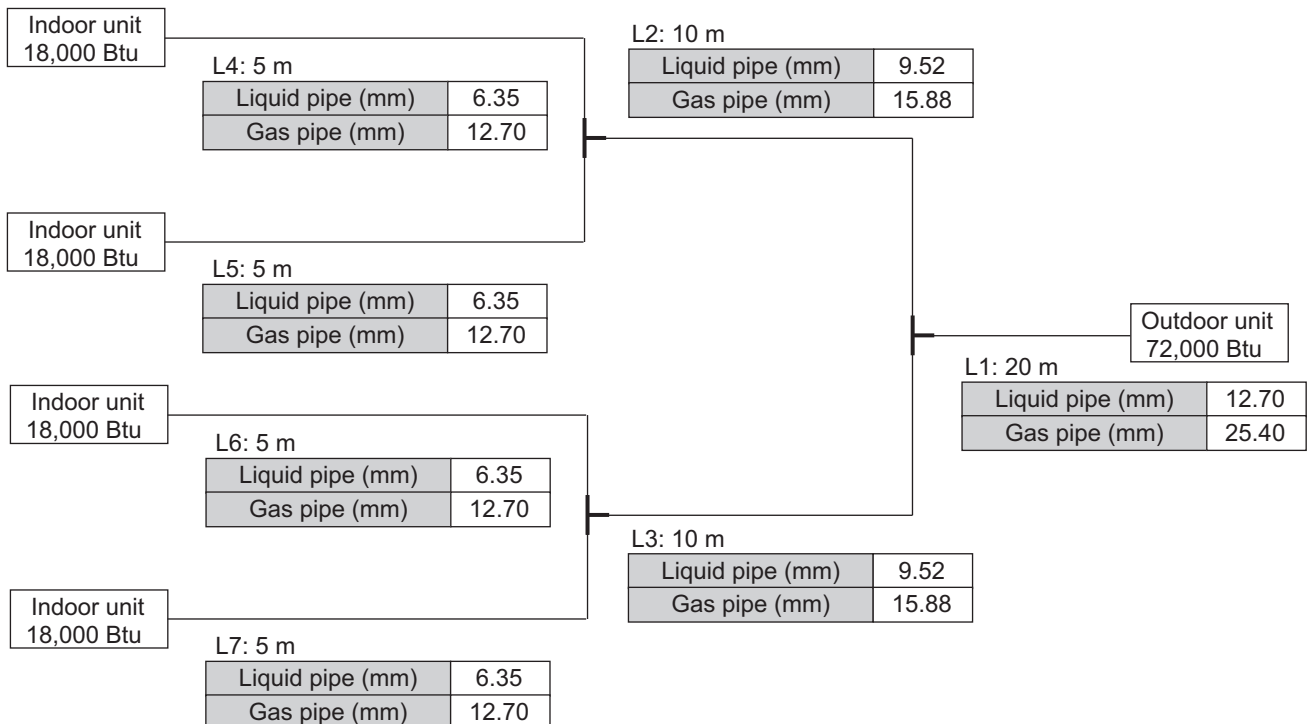

Liquid pipe diameter (mm)	Piping length (m)	Coefficient
12.70	20	A = 20
9.52	20	B = 20
6.35	20	C = 20

Applying the formula,

$$(20 \times 110) + (20 \times 50) + (20 \times 30) - 3,300 = 500$$

The additional charging amount is 500 g.

3. Pipe installation

3-1. Caution of piping

⚠ CAUTION

Keep the permissible length of every piping limitation to prevent a defect or cooling/heating failure.

• Piping material:

- Use the designated size (diameter and thickness) of refrigerant pipes.
- Those pipes purchased locally may contain dust inside. Blow out the dust by dried inert gas when using.
- To process the branch, do not use T-shaped pipe, which causes a uneven refrigerant flow. Use the optionally available standard branch pipe.

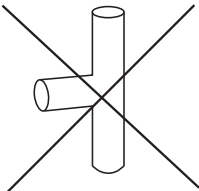
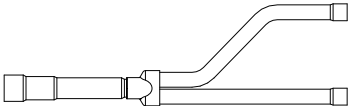
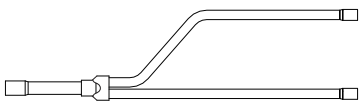
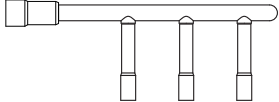
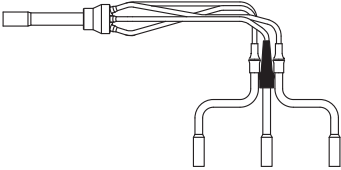
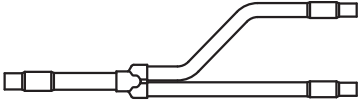
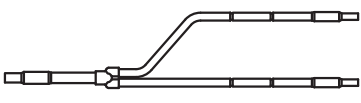
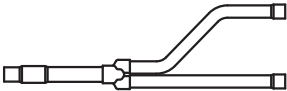
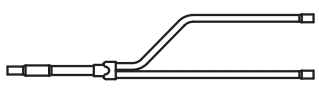
 T-tube	UTP-SX272A (Gas)  Twin connection type Double twin connection type	UTP-SX272A (Liquid)  Twin connection type Double twin connection type
	UTP-SX372A (Gas)  Triple connection type	UTP-SX372A (Liquid)  Triple connection type
	UTP-SX236A (Gas)  Double twin connection type for 72 model	UTP-SX236A (Liquid)  Double twin connection type for 72 model
	UTP-SX254A (Gas)  Double twin connection type for 90 model	UTP-SX254A (Liquid)  Double twin connection type for 90 model

- When replacing the unit, never use piping which has been used for previous installations. Only use the new piping.

• Piping process stage:

- Be careful to avoid the dust or water falling into the pipe when performing piping process and piping installation.
- When processing the pipe, make the number of bending portion as few as possible, and the bending radius as large as possible.
- If the diameter of the required pipe is different from the branch unit, either cut it out or use the reducer.

(continued)

⚠ CAUTION**• Brazing:**

- While brazing the pipes, be sure to blow dry nitrogen gas through them.
- If nitrogen gas is not blown through the pipes while they are being brazed, an oxidized layer may form on the inside of the pipes. If this occurs, the cooling efficiency may decrease and the air conditioner unit (compressor, valves, etc.) cause malfunction.

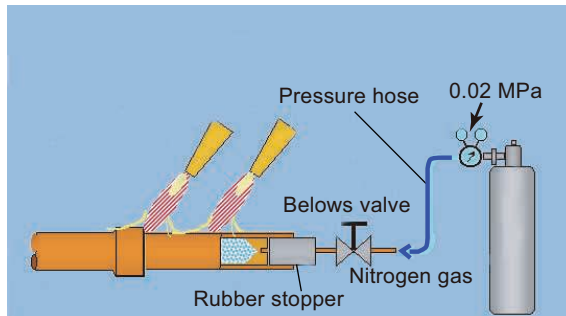

- When brazing the pipes, do not use flux. If the flux is chlorine-based, the pipes will corrode and when the flux contains fluorine, the refrigerant oil will deteriorate, etc. Using the flux has an adverse affect on the refrigerant piping system.
- For brazing materials, use phosphor copper solder that does not require flux.

• Piping treatment:

- The pipes vibrate, expand, and contract during operation, so if loads are concentrated in one area, it could cause cracks in the pipes. Provide the pipe supports every 2 to 3 m.
- Make sure to insulate the refrigeration pipes separately with ample thickness of heat-resistant polyethylene form etc. For the connecting portion, apply the enough insulation to avoid any gap.

■ Example**• Brazing**

While brazing the pipes, be sure to blow dry nitrogen gas through the pipes. If not used, it will be caused to damage for compressor and clog the strainer and electronic expansion valve.

Example: Inside state of brazing pipe section



3-2. Piping to outdoor unit

■ Knocking out procedure in piping

⚠ CAUTION

- Be careful not to deform or scratch the panel while opening the knock out holes.
 - To protect the piping insulation after opening a knock out hole, remove any burrs from the edge of the hole. It is recommended to apply rust prevention paint to the edge of the hole.
-
- Pipes can be connected from 3 directions, front, lateral side, and bottom. (Fig. A)
 - When connecting at the bottom, remove the service panel and piping cover on the front of the outdoor unit, and open the knock out hole provided at the bottom corner of the piping outlet.
 - It can be installed as shown as on "Fig. B" cutting out the 2 slits as indicated on "Fig. C". (When cutting slits, use a steel saw.)

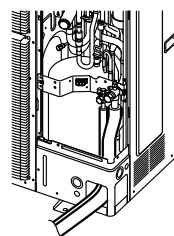
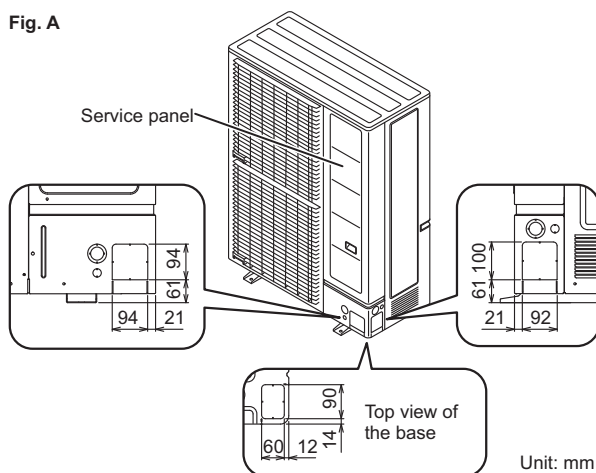

Front connection

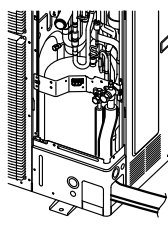

Lateral connection

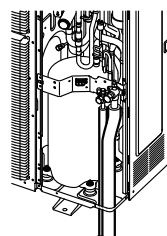

Bottom connection

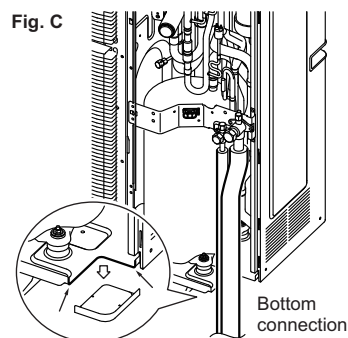
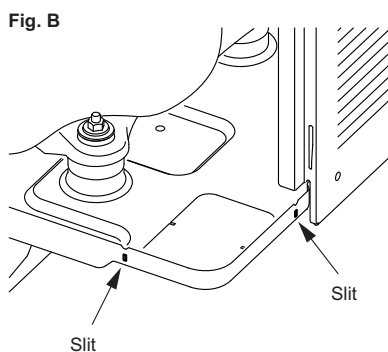

3-3. Pipe connection

■ Precautions for connecting simultaneous operation multi

⚠ CAUTION

- Use genuine branch pipes for the refrigerant piping branches. Branch pipes are twin or triple type for simultaneous operation, and may be used for piping between the outdoor and indoor units.
- Select a twin or triple type branch pipe and purchase it before starting the installation work.
- Shorten the length of branch pipes from a branch to indoor unit as short as possible. Maximum length: 20 m or less
- Branch pipes shall be connected by welding (brazing).
- Any vertical piping shall be in the part of the main piping. If a main pipe is bent, keep the straight part more than 10 times the diameter of the connected pipe. A variance in the amount of refrigerant may be caused if the straight part is short.
- For details, refer to the Installation manual of branch pipes.

■ Bending pipes

⚠ CAUTION

- To prevent breaking of the pipe, avoid sharp bends. Bend the pipe with a radius of curvature of 100 mm to 150 mm.
- If the pipes are bent or stretched repeatedly at the same place, the material will harden making it difficult to bend or stretch them any more.
- Do not bend or stretch the pipes more than three times, otherwise it will be break.

NOTES:

- If pipes are shaped by hand, be careful not to collapse them.
- Do not bend the pipes at an angle of more than 90°.

■ Removing the pinch pipes

⚠ WARNING

Remove the pinch pipe only when the internal gas is completely drained as shown on the below instructions.

If gas still remains inside, the piping may crack if you melt the brazing filler metal of the junction area with burner.

Before Connecting the piping, remove the pinch pipe in accordance with the following instructions:

1. Verify that the liquid side and gas side 3-way valves are closed.

3-way valves

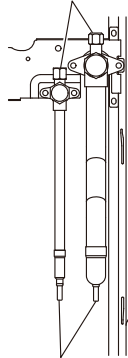

Pinch pipes

2. Cut the end of the liquid side and gas side pinch pipe and vent the gas inside the pinch pipe.

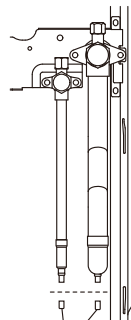

End of pinch pipes

3. After all the gas is vented, melt the brazing filler metal on connecting part using a torch and remove the pinch pipe.

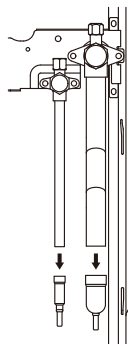

■ Connecting the pipes

⚠ CAUTION

- Seal the pipe route hole with putty (locally purchased) such that there are no gaps. Small insects or animals that are trapped in the outdoor unit may cause a short circuit in the electrical component box.
 - After completing all the pipe connection by brazing, perform the indoor unit pipe connection with a flare joint.
 - When removing the pinch pipe or brazing the joint pipe, carry out the work while cooling down the 3-way valve sufficiently.
-
- Braze the joint pipe onto the 3-way valves at the liquid and gas side. Install the joint pipe appropriately so that it can be connected easily with the main pipe.
 - Braze the joint pipe at the liquid and gas side with the main pipe.
 - Be sure to supply nitrogen when brazing.

Connection example (For Gas pipe $\phi 22.22$)

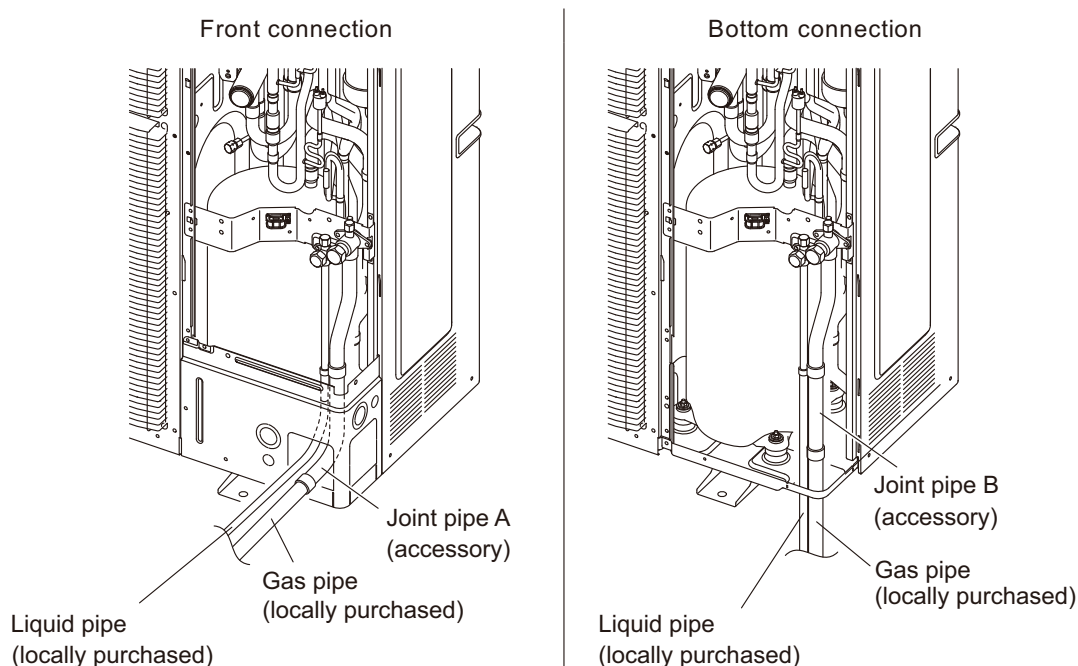

■ Handling precautions for valves

- Mounted part of blank cap is sealed for protection.
- Fasten blank cap tightly after opening valves.

Blank cap (mm [in])	Tightening torque (N·m [kgf·cm])
6.35 (1/4)	20 to 25 (200 to 250)
9.52 (3/8)	20 to 25 (200 to 250)
12.70 (1/2)	28 to 32 (280 to 320)
15.88 (5/8)	30 to 35 (300 to 350)
19.05 (3/4)	35 to 40 (350 to 400)

Operating the valves:

- Use a hexagon wrench (size 4 mm).
- Opening:
 1. Insert the hexagon wrench into the valve shaft, and turn it counterclockwise.
 2. Stop turning when the valve shaft can no longer be turned. (Open position)
- Closing:
 1. Insert the hexagon wrench into valve shaft, and turn it clockwise.
 2. Stop turning when the valve shaft can no longer be turned. (Closed position)

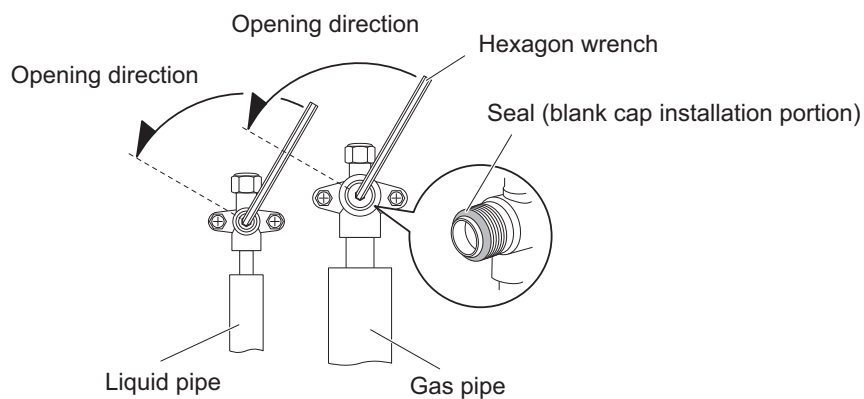

3-4. Branch pipes

■ Branch pipe selection

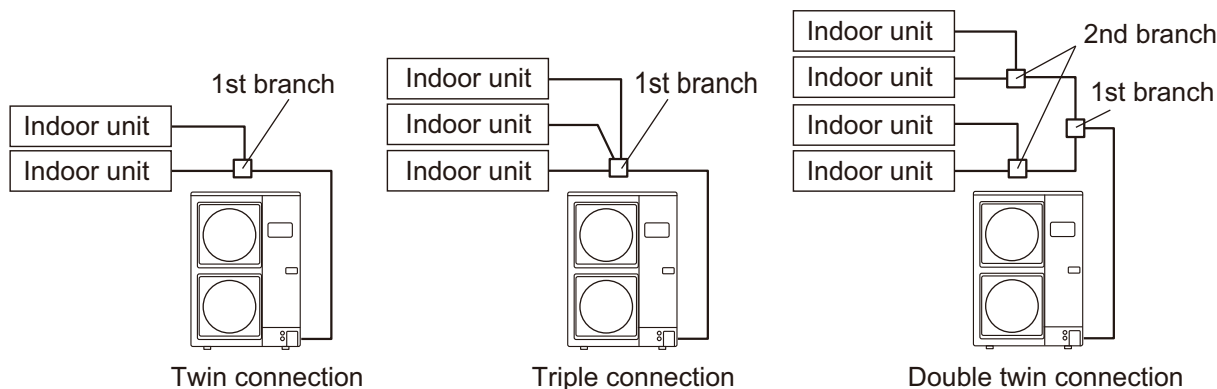

Connection type	Kit name	Number of kits	Outdoor unit	Piping diameter		Number of indoor unit	Place of use (branch)
				Kit to outdoor unit *1	Kit to indoor unit		
Twin	UTP-SX272A	1	AOHG72LRLA	Liquid: 12.70 (1/2)	Liquid: 9.52 (3/8)	2	1st
			AOHG90LRLA	Gas: 25.40 (1)	Gas: 15.88 (5/8)		
Triple	UTP-SX372A	1	AOHG72LRLA	Liquid: 12.70 (1/2)	Liquid: 9.52 (3/8)*2	3	1st
			AOHG90LRLA	Gas: 25.40 (1)	Gas: 15.88 (5/8)		
Double twin	UTP-SX272A	1	AOHG72LRLA	Liquid: 12.70 (1/2)	Liquid: 9.52 (3/8)	4	1st
	UTP-SX236A	2		Gas: 25.40 (1)	Gas: 15.88 (5/8)		2nd
	UTP-SX272A	1	AOHG90LRLA	Liquid: 12.70 (1/2)	Liquid: 9.52 (3/8)	4	1st
	UTP-SX254A	2		Gas: 25.40 (1)	Gas: 15.88 (5/8)		2nd
				Liquid: 9.52 (3/8)*2	Gas: 15.88 (5/8)		

*1: For the diameter of the connection piping between the outdoor unit and the branch pipes, refer to the installation manual of the outdoor unit.

*2: It is necessary to attach the adapter (accessory) to the half union of the liquid pipe of the indoor unit.

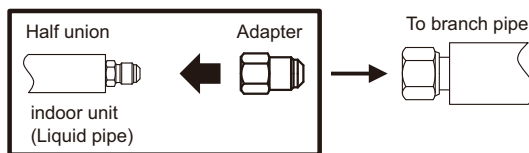

NOTES:

- When using the adapter (accessory), be careful not to overtighten the nut, or the smaller pipe may be damaged.

Adapter type	Tightening torque (N•m [kgf•cm])
6.35 → 9.52	14 to 18 (140 to 180)

- Use appropriate wrenches to avoid damaging the connection thread by overtightening the flare nut.
- Apply wrenches on both the flare nut (locally purchased), and adapter to tighten them.

■ Installation procedure for Twin type and Double twin type

⚠ CAUTION

- Do not mistake the direction of connection.
- Set the piping from the branch pipe to the indoor units to be the same length. (Max. difference: 8 m)
- Shorten the length of the piping after branching as much as possible. (Max. length: 20 m)

1. Check the direction of connection.

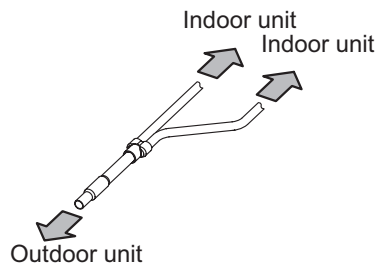

2. If the diameter of the connection piping is too large, use a pipe cutter to cut as shown below.

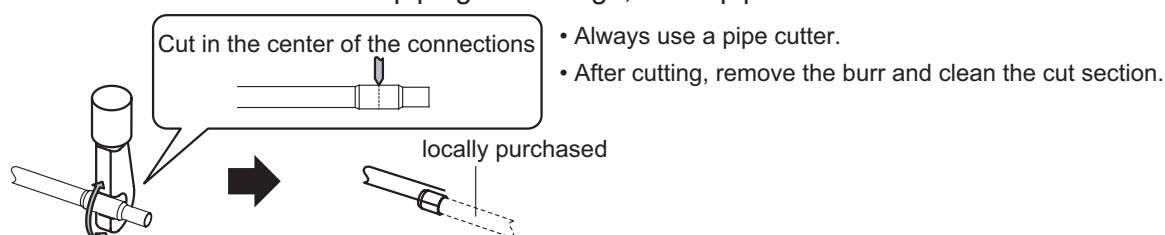

3. Check the positioning of branch pipes.

If it is placed horizontally, keep it within $\pm 15^\circ$. Otherwise, it will not separate the refrigerant evenly, causing a reduction in performance.

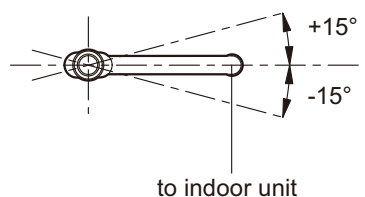

4. Place the branch pipe in a horizontal position as far as possible.
- a. Only place the branch pipe as shown below during unavoidable circumstances.

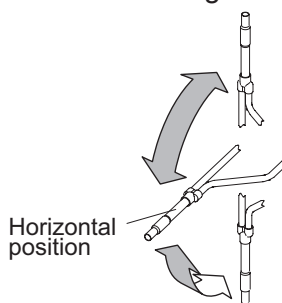

- b. When connecting the main piping, do not bend it near the connection section. If the main pipe must be bent due to unavoidable circumstances, ensure that the linear section is 10 times or more than the diameter of the connection piping.

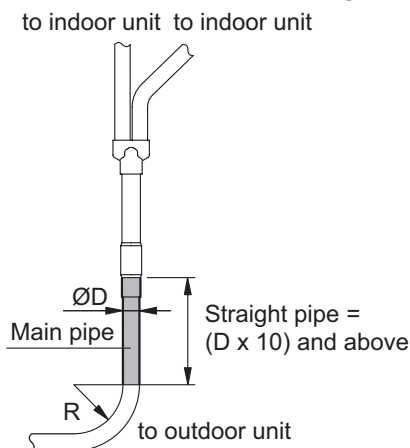

5. Welding the piping
- Check that the connection piping is securely inserted into the branch pipe before welding.

⚠ CAUTION

- During piping work, apply nitrogen gas while brazing the pipes. If pipes are brazed without applying nitrogen gas, it will create a large amount of oxidation film, which will cause a critical malfunction.
- To prevent moisture or foreign matter from entering during work, do not leave the piping open.
- Refer to installation manual supplied with the outdoor unit for sealing test evacuation procedures.

- Do not weld the rubber on the branch pipe. (UTP-SX372A only)

6. Installing the cable tie (UTP-SX372A only)
- a. Install the cable tie as shown in the following.

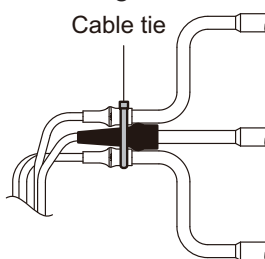

- b. After installing the cable tie, cut away the excess portion neatly.

7. After brazing the pipes, use the supplied heat insulation to insulate them.
- a. Remove the protective sheet from the double-stick tape that is affixed to the heat insulation.

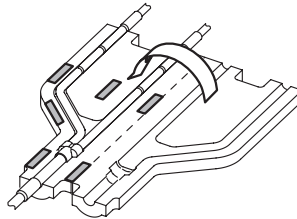

- b. Use tape (locally purchased) to seal the seam so that there will be no gap at the junction between the aforementioned heat insulation and the heat insulation on the local piping.

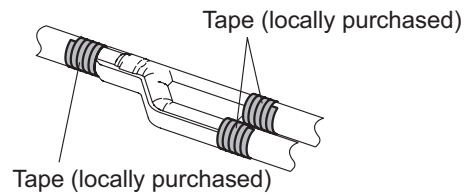

- c. If you worry about refrigerant noise, install additional sound insulation (locally purchased) over the heat insulation.

⚠ CAUTION

- Be sure to install the heat insulation on liquid pipes and gas pipes. Unless they are thermally insulated, water condensation can cause accidents or reduction in performance.
- After installing the heat insulation, if you worry about possible condensation due to the high humidity of installation position, use locally purchased heat insulation to reinforce insulation.

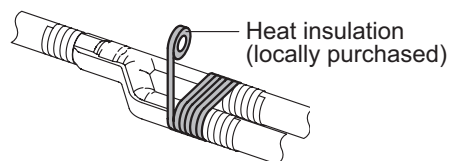

■ Installation procedure for Triple type

⚠ CAUTION

- Do not mistake the direction of connection.
- Set the piping from the branch pipe to the indoor units to be the same length. (Max. difference: 8 m)
- Shorten the length of the piping after branching as much as possible. (Max. length: 20 m)

1. Check the direction of connection.

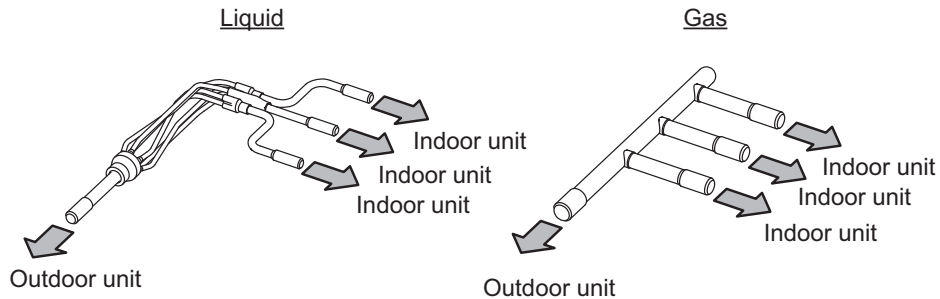

2. If the diameter of the connection piping is too large, use a pipe cutter to cut as shown below.

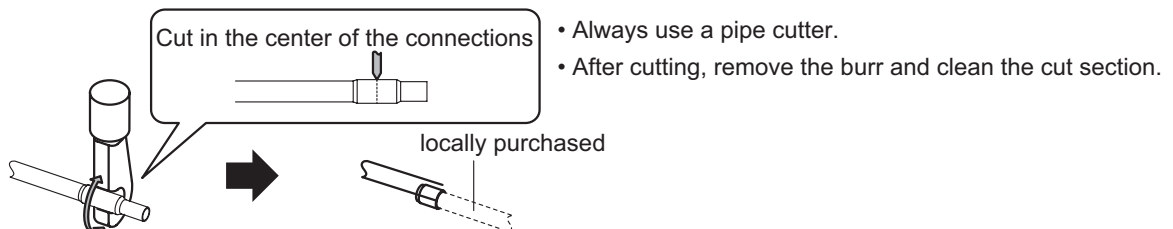

3. Check the positioning of branch pipes.

If it is placed horizontally, keep it within $\pm 15^\circ$. Otherwise, it will not separate the refrigerant evenly, causing a reduction in performance.

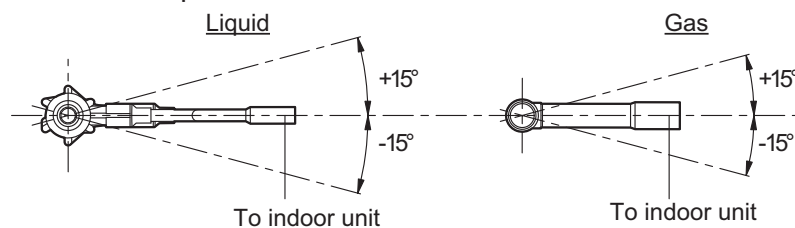

4. Place the branch pipe in a horizontal position as far as possible.
 a. Only place the branch pipe as shown below during unavoidable circumstances.

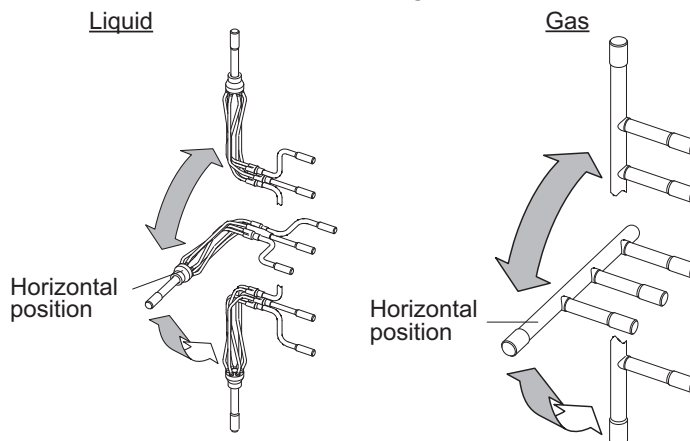

- b. When connecting the main piping, do not bend it near the connection section. If the main pipe must be bent due to unavoidable circumstances, ensure that the linear section is 10 times or more than the diameter of the connection piping.

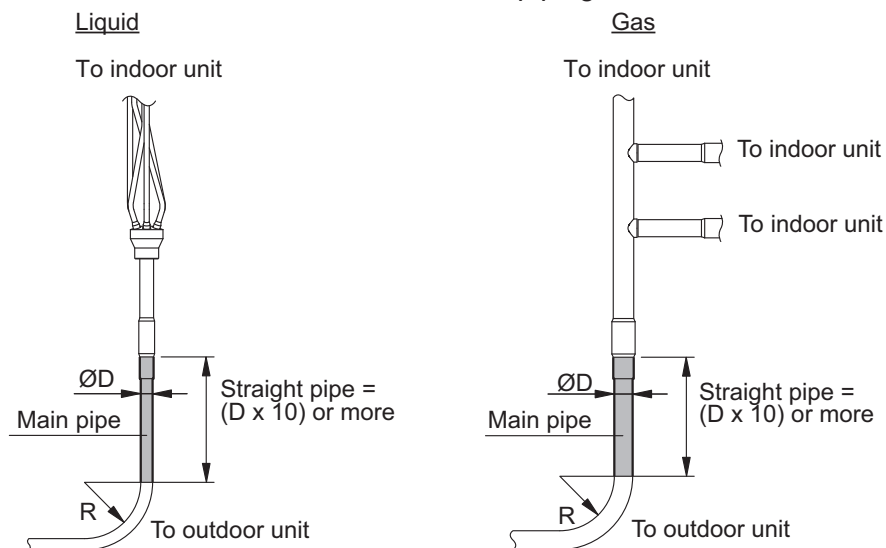

5. Welding the piping
 Check that the connection piping is securely inserted into the branch pipe before welding.

⚠ CAUTION

- During piping work, apply nitrogen gas while brazing the pipes. If pipes are brazed without applying nitrogen gas, it will create a large amount of oxidation film, which will cause a critical malfunction.
- To prevent moisture or foreign matter from entering during work, do not leave the piping open.
- Refer to installation manual supplied with the outdoor unit for sealing test evacuation procedures.

6. After brazing the pipes, use the supplied heat insulation to insulate them.
- Remove the protective sheet from the double-stick tape that is affixed to the heat insulation.

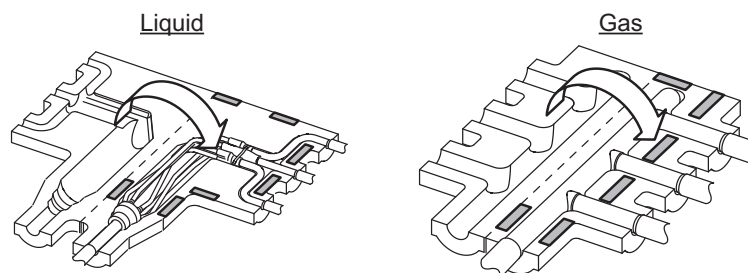

- Use tape (locally purchased) to seal the seam so that there will be no gap at the junction between the aforementioned heat insulation and the heat insulation on the local piping.

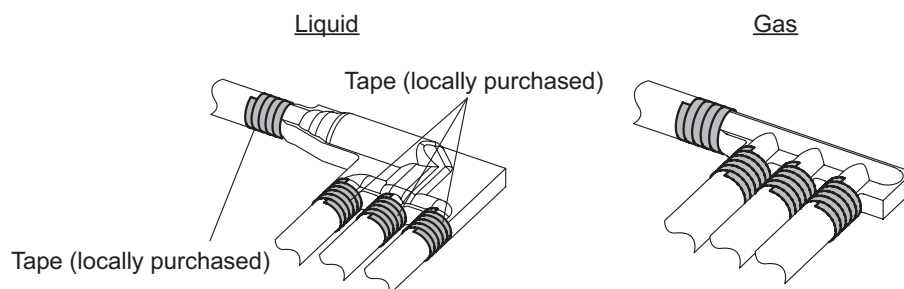

⚠ CAUTION

- Be sure to install the heat insulation on liquid pipes and gas pipes. Unless they are thermally insulated, water condensation can cause accidents or reduction in performance.
- After installing the heat insulation, if you worry about possible condensation due to the high humidity of installation position, use locally purchased heat insulation to reinforce insulation.

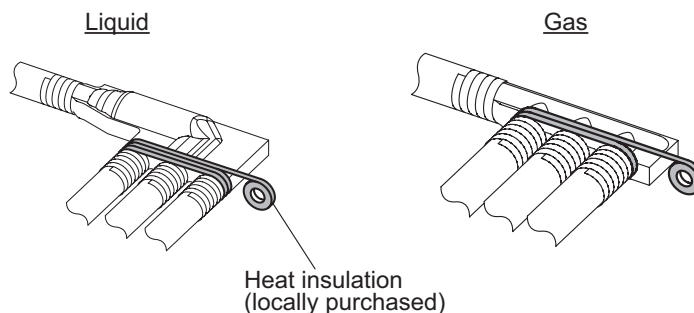

4. Wiring design

4-1. Precaution for electrical wiring

Regulation on wire diameter and selecting circuit breaker size differ by locality. Install in accordance with local rules and regulations.

⚠ WARNING

- Wiring connections must be performed by a qualified person in accordance with the specifications. The voltage rating for this product is 400 V at 50 Hz. It should be operated within the range of 342 to 456 V.
- Before connecting the wires, make sure the power supply is OFF.
- Never touch electrical components immediately after the power supply has been turned off. Electrical shock may occur. After turning off the power, always wait 10 minutes or more before touching electrical components.
- Use a dedicated power supply circuit. Insufficient power capacity in the electrical circuit or improper wiring may cause electric shock or fire.
- Install a breaker at the power supply for each outdoor unit. Improper breaker selection can cause electric shock or fire.
- Install a leakage circuit breaker in accordance with related laws and regulations. An improperly installed electrical box cover can cause serious accidents such as electric shock or fire through exposure to dust or water.
- A circuit breaker is installed in the permanent wiring. Always use a circuit that can trip all the poles of the wiring and keep an isolation distance of at least 3 mm between the contacts of each pole.
- Use designated cables and power cables. Improper use may cause electric shock or fire by poor connection, insufficient insulation, or over current.
- Do not modify power cable, use extension cable, or branch wiring. Improper use may cause electric shock or fire by poor connection, insufficient insulation, or over current.
- Connect the connector cable securely to the terminal. Check no mechanical force bears on the cables connected to the terminals. Faulty installation can cause a fire.
- Use crimp-type terminals and tighten the terminal screws to the specified torques, otherwise, abnormal overheating may be produced and possibly cause serious damage inside the unit.
- Make sure to secure the insulation portion of the connector cable with the cable clamp. Damaged insulation can cause a short circuit.
- Fix cables so that cables do not make contact with the pipes (especially on high pressure side). Do not make power supply cable and transmission cable come in contact with valves (Gas).
- Never install a power factor improvement condenser. Instead of improving the power factor, the condenser may overheat.
- Be sure to perform the grounding work. Do not connect grounding wires to a gas pipe, water pipe, lightning rod, or grounding wire for a telephone.
 - Connection to a gas pipe may cause a fire or explosion if gas leaks.
 - Connection to a water pipe is not an effective grounding method if PVC pipe is used.
 - Connection to the grounding wire of a telephone or to a lightning rod may cause a dangerously abnormal rise in the electrical potential if lightning strikes.
 - Improper grounding work can cause electric shocks.
- Securely install the electrical box cover on the unit. An improperly installed service panel can cause serious accidents such as electrical shock or fire through exposure to dust or water.
- The primary power supply capacity is for the air conditioner itself, and does not include the concurrent use of other devices.

(continued)

⚠ WARNING

- Do not start operation until the refrigerant is charged completely. The compressor will fail if it is operated before the refrigerant piping charging is complete.
- Transmission cable between indoor unit and outdoor unit is 230 V.
- Be sure not to remove thermistor sensor etc. from power wiring and connection wiring. Compressor may fail if operated while removed.
- Start wiring work after closing branch switch and over current breaker.
- Use an earth leakage breaker that is capable of handling high frequencies. Because the outdoor unit is inverter controlled, a high-frequency earth leakage breaker is necessary to prevent a malfunction of the breaker itself.
- When using an earth leakage breaker that has been designed solely for ground fault protection, be sure to install a fuse-equipped switch or circuit breaker.
- Do not connect the AC power supply to the transmission line terminal board. Improper wiring can damage the entire system.
- Do not use crossover power supply wiring for the outdoor unit.
- If the temperature surrounding the breaker is too high, the amperage at which the breaker cuts out may decrease.

4-2. Power supply cable wiring

■ Power supply cable specifications

● Indoor unit

Electrical requirement			
Power supply cable	Minimum conductor size	mm ²	1.5
Transmission cable			
Bus wire	Minimum conductor size	mm ²	0.33
	Maximum length	m	500*

NOTES:

- *: This length shall be the total extended length in the system of the group. (Total length of bus wire and remote controller cable.)
- Use confirmed cable with type 245 IEC 57. (Power supply cable or transmission cable)
- Perform all electrical work according to the standard.
- Install a circuit breakers, which have the terminal spacing of more than 3 mm, in a place of near the indoor unit and outdoor unit.
- Wiring size must comply with the applicable local and national code.

● Outdoor unit

Breaker and wiring specifications			
Breaker capacity		A	30
Power supply cable	Minimum conductor size	mm ²	6

NOTES:

- Use confirmed cable with type 60245 IEC 57.
- Perform all electrical work according to the standard.
- Install a circuit breaker with a contact gap of at least 3 mm in all poles nearby the units. (Both indoor units and outdoor units)
- Install the circuit breaker nearby the units.
- Wiring size must comply with the applicable local and national code.

● Wired remote controller

Electrical requirement			
Remote controller cable	Minimum conductor size	mm ²	0.33
	Maximum length	m	500*
	Wire type	Use sheathed PVC cable, Polar 3 core	

NOTES:

- *: This length shall be the total extended length in the system of the group. (Total length of bus wire and remote controller cable.)
- Use confirmed cable with type 245 IEC 57.
- Perform all electrical work according to the standard.

⚠ CAUTION

- Be sure to execute the electrical work according to the Laws of each country and the Installation Instructions. In addition, be sure to set as exclusive line and use the rated voltage and circuit breaker.
- Above “Conductor size” and “Breaker capacity” are minimum value.
- Transmission cable between indoor unit and outdoor unit is 230 V.
- Regulation of conductor size and circuit breaker differs by each locality, refer in accordance with local rules.
- Start wiring work after closing branch switch and over current breaker.
- Specific wiring requirement should be applied Type 245 IEC 57 or equivalent.
- To prevent the electrical noise malfunction and hazards from insulation failure, the unit should be connected to ground.
- A disconnect switch may be required for ease of maintenance in accordance with local regulation for each unit. Check the local rules and regulations. Make the wire length between disconnect switch and unit terminal as short as possible.
- All field wiring and components must be provided by a licensed electrician.
- Use copper conductors only.

Power supply cable wiring

Power cable	Junction box—indoor unit (primary)	3-wires
	Junction box—indoor unit (secondary)	2-wires
	Outdoor unit	2-wires
Bus wire	Indoor unit—indoor unit	3-wires
Remote controller cable		3-wires

Example:

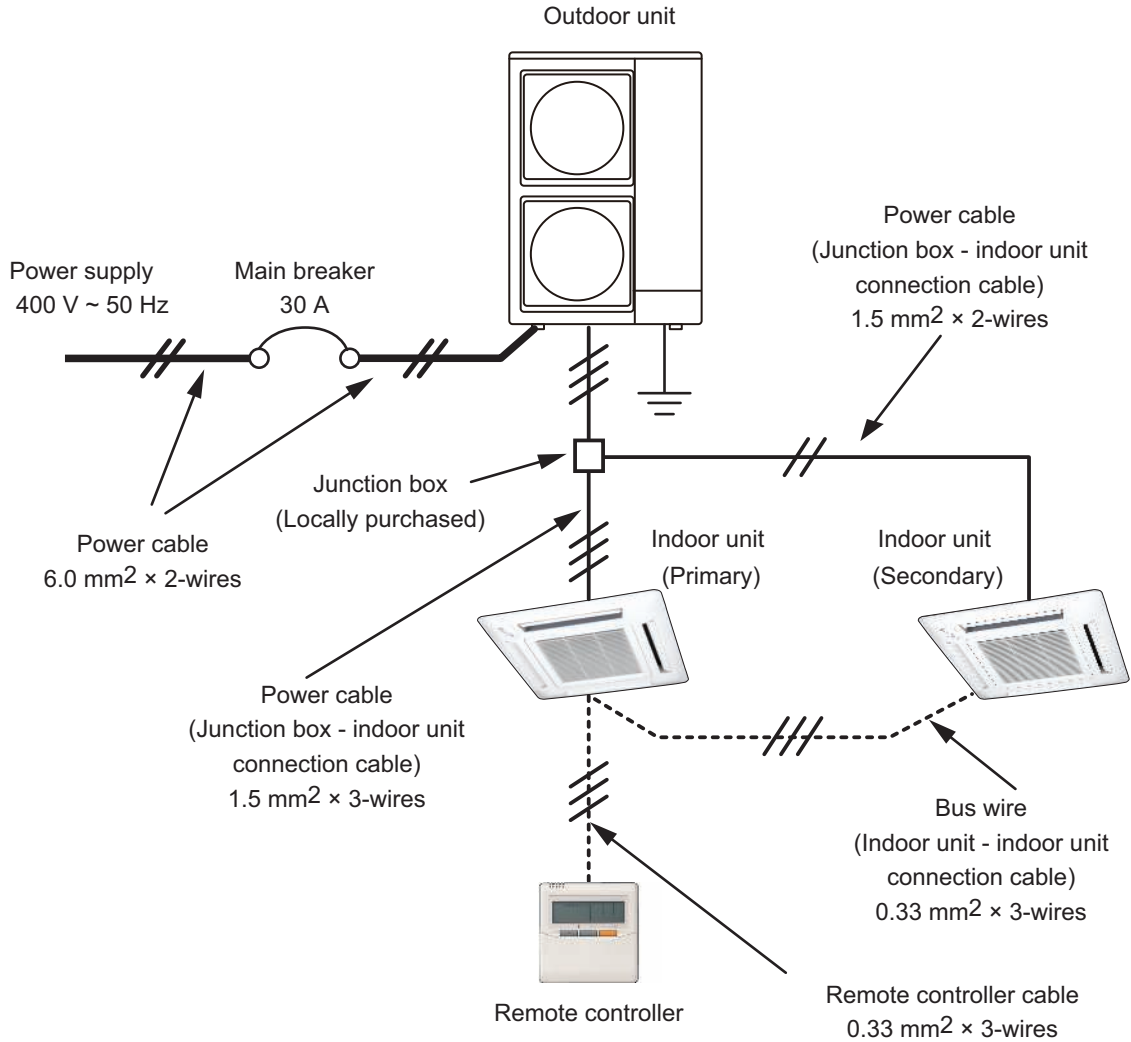

■ Wiring connection rules

NOTES:

- Connect serial wire only to the primary unit. (If serial wire was connected from primary unit to secondary unit, the air conditioner will not operate.)
- Do not loop the wiring between remote controllers.

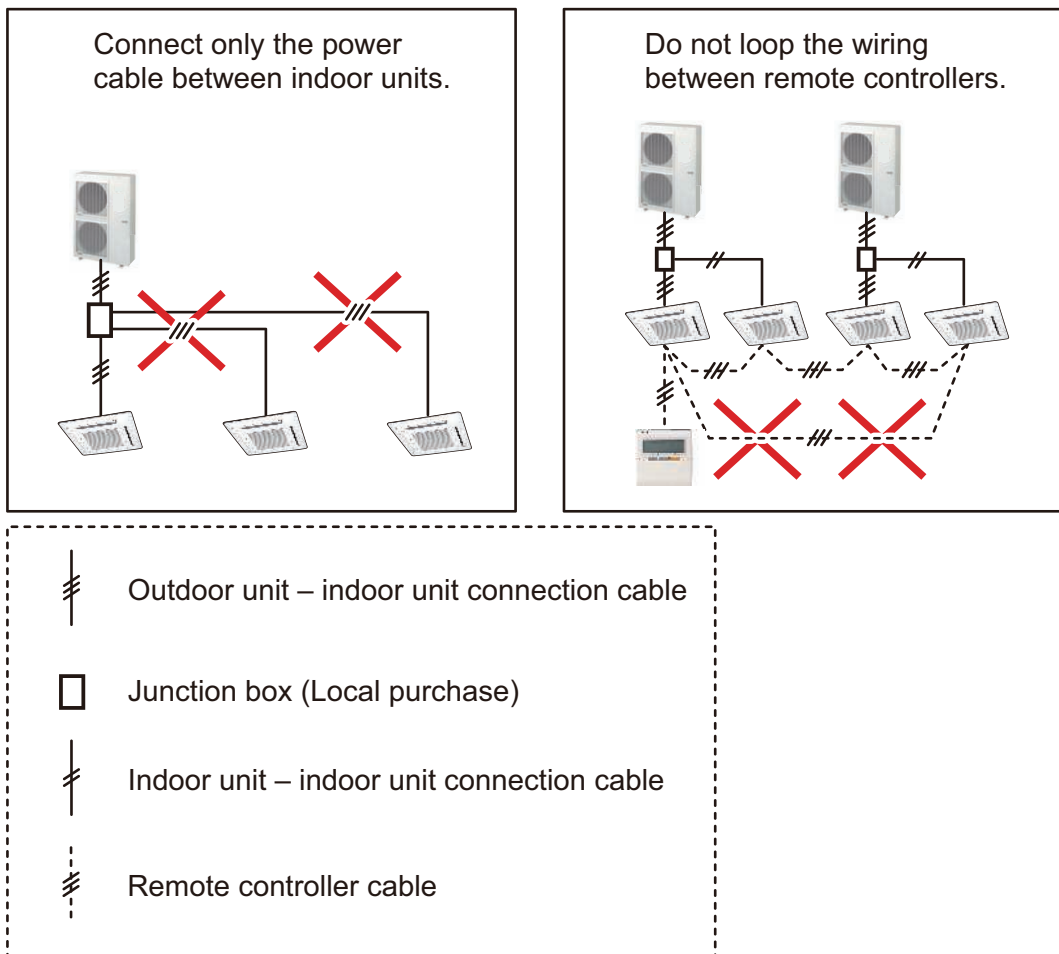

■ Wiring method

The wiring method conforms to the following diagram.

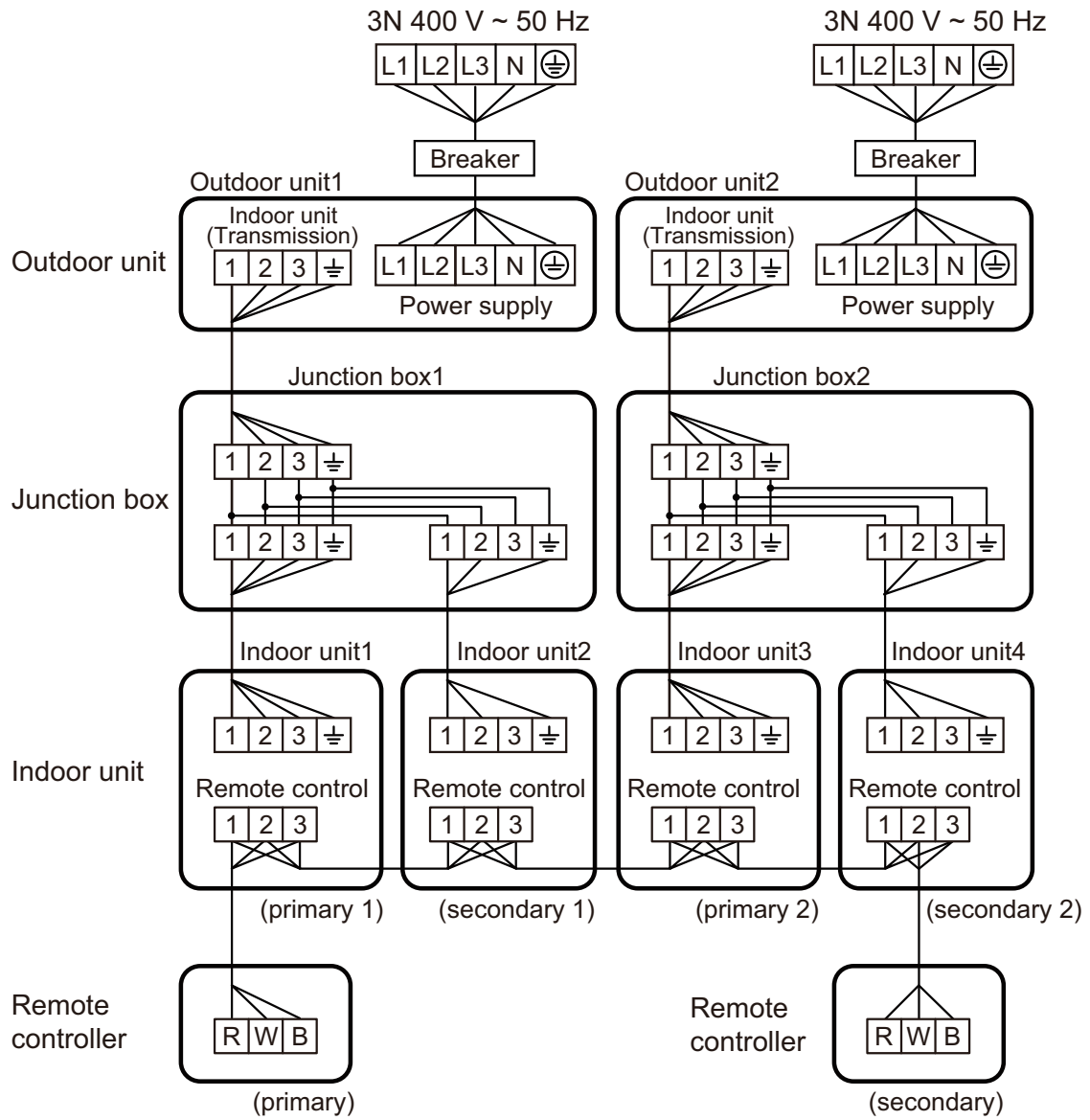

SYSTEM
DESIGN

SYSTEM
DESIGN

■ Recommended wiring connection

Up to 3 indoor units can be connected to one outdoor unit.

Operation of all indoor units is same.

The simultaneous multi system is effective for anomalistic floors and wide floors.

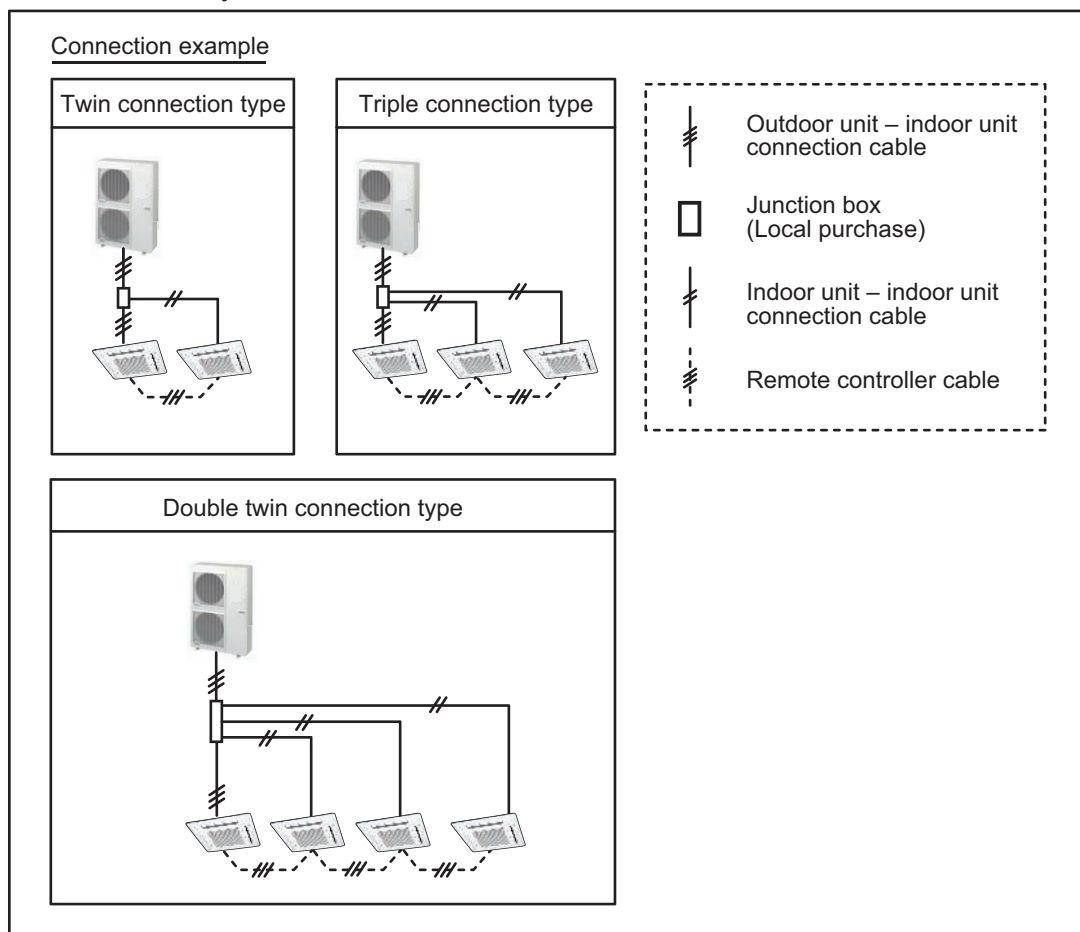

4-3. Control patterns

■ 1-Remote controller control

This is the most basic system. Wired type or wireless type remote controller can be selected.

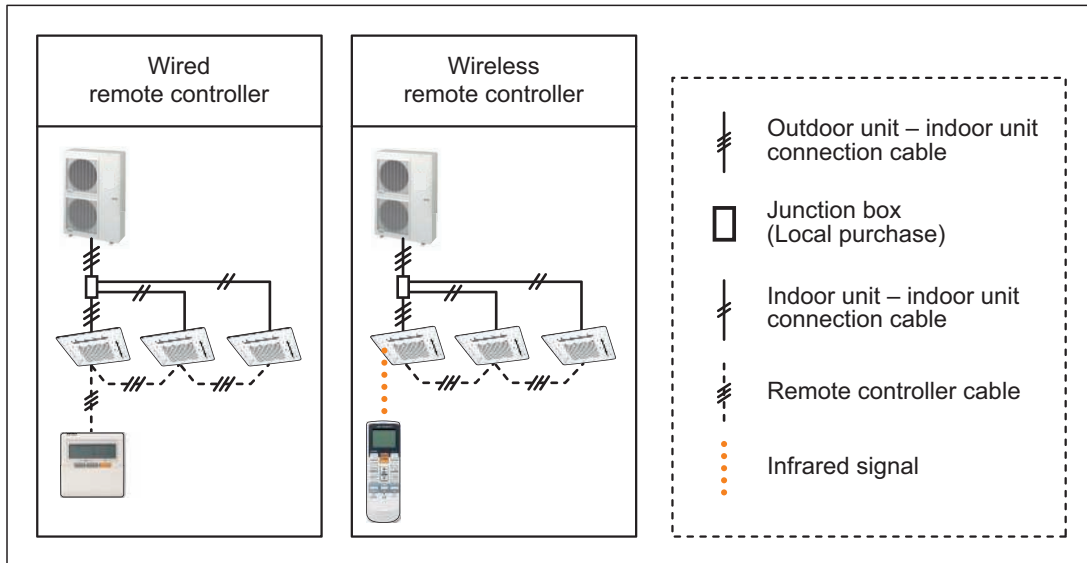

NOTES:

- When using a wireless type remote controller, install IR receiver unit to the indoor units (Slim duct type, Duct type).
- In simultaneous multi connection the timer and 10 °C HEAT functions by using the wireless remote controller cannot be used.

■ 2-Remote controllers control

Local control from a remote point is possible using 2-remote controllers.

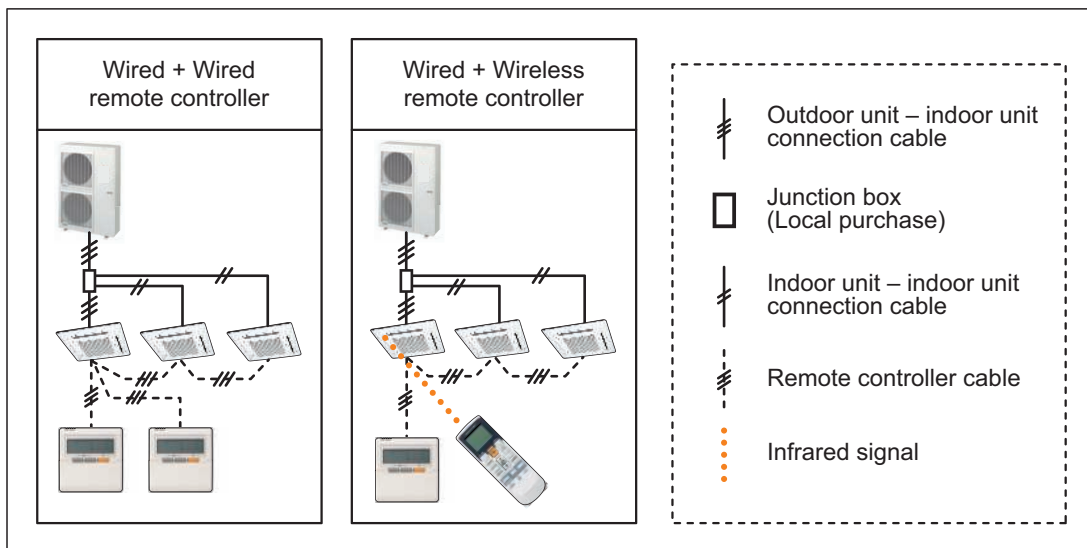

NOTES:

- For 2 wired-type remote controllers, specify a primary and secondary remote controller.
- The TIMER and 10 °C HEAT (Wireless remote controller only) functions of remote controller specified as the secondary cannot be used.
- In simultaneous multi connection, the TIMER and 10 °C HEAT functions by using the wireless remote controller cannot be used.
- When using a wireless type remote controller, install IR receiver unit to the indoor units (Slim duct type, Duct type).

Remote controller group control

1 or 2-remote controllers can simultaneously control up to 16 indoor units.

Wired remote controller type

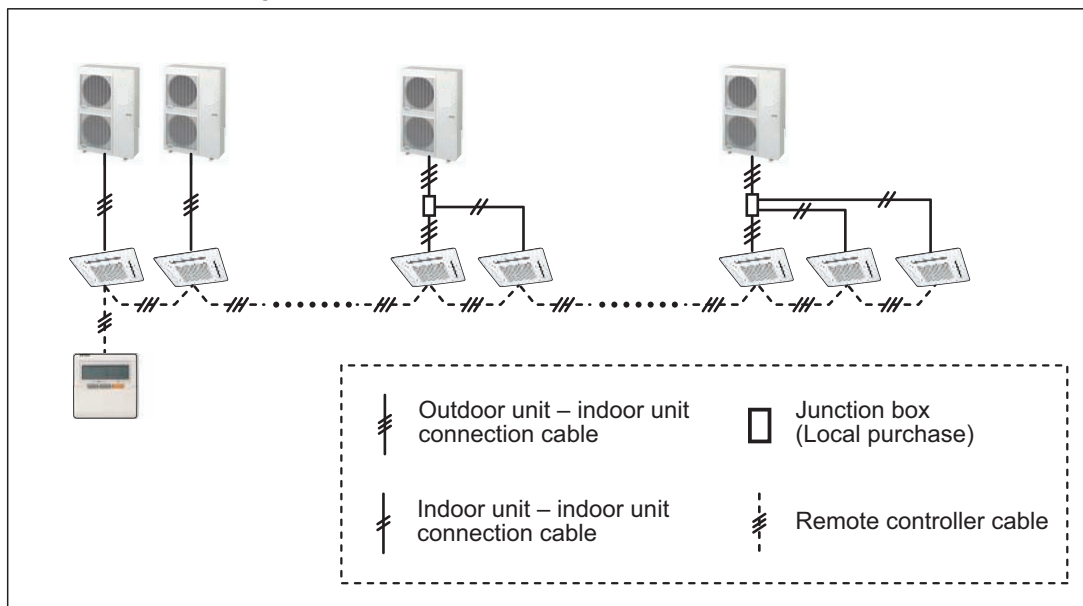

Wireless remote controller type

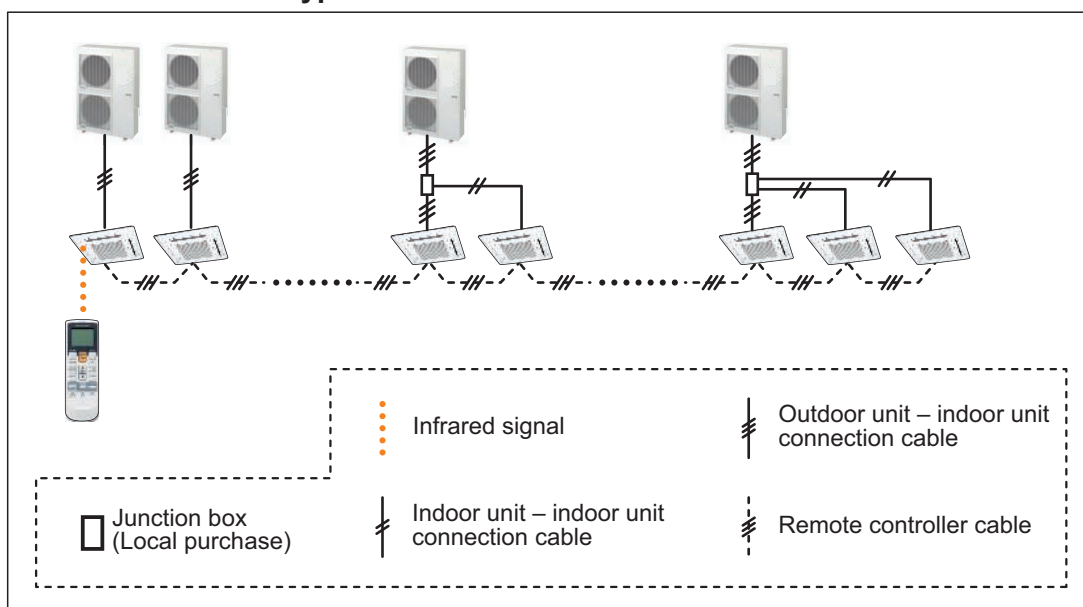

NOTES:

- When using a wireless type remote controller, install IR receiver unit to the indoor units (Slim duct type, Duct type).
- In simultaneous multi connection, the TIMER and 10 °C HEAT functions by using the wireless remote controller cannot be used.
- In the group connection of different indoor unit models, the functions which can be set by using the wired remote controller are limited.

■ Connection examples

- Example 1 (OK)

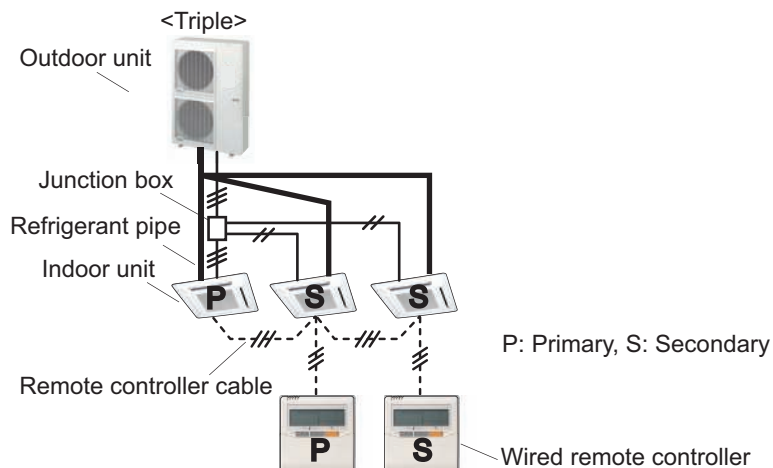

NOTE: Maximum of 2 remote controllers can be connected in the same remote controller group. Also, a remote controller can be connected to any indoor unit.

- Example 2 (Prohibited)

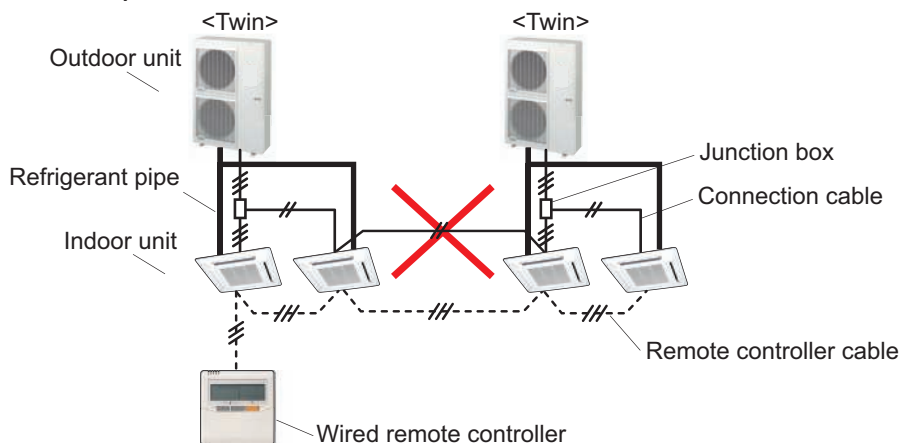

NOTE: Do not connect between indoor units crossing over a refrigerant circuit.

- Example 3 (Prohibited)

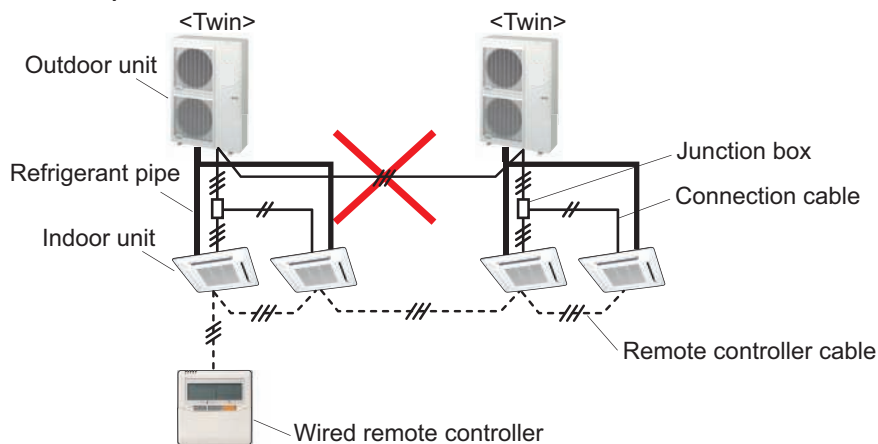

NOTE: Do not connect outdoor units crossing.

• Example 4 (Prohibited)

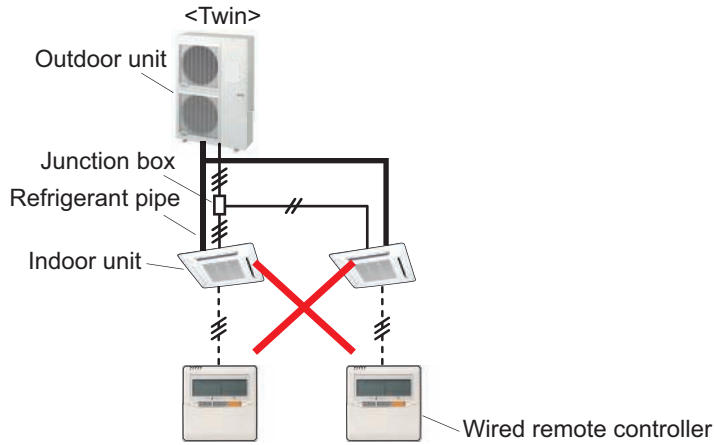

NOTE: When connecting more than 2 indoor units in same refrigerant circuit, the remote controller cable must be connected between indoor units.

• Example 5 (Prohibited)

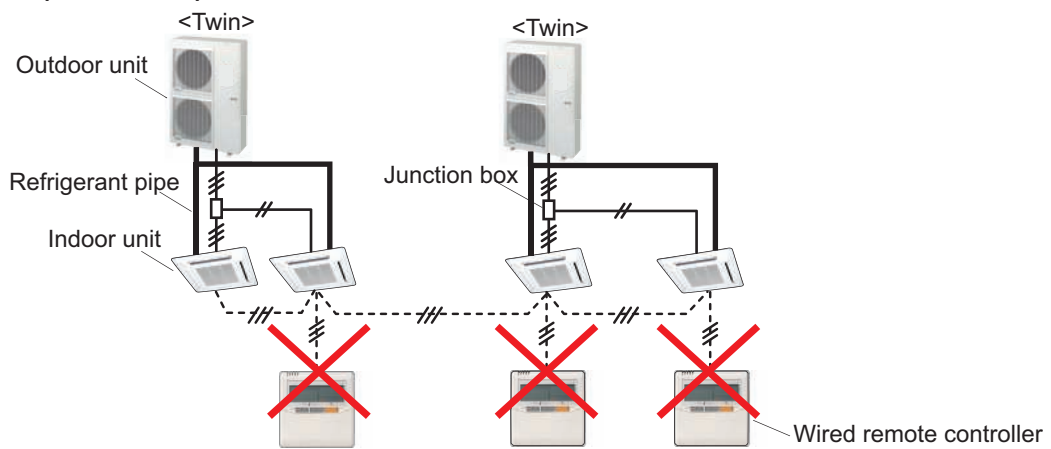

NOTE: Do not connect 3 or more remote controllers in the same remote controller group.

• Example 6 (Prohibited)

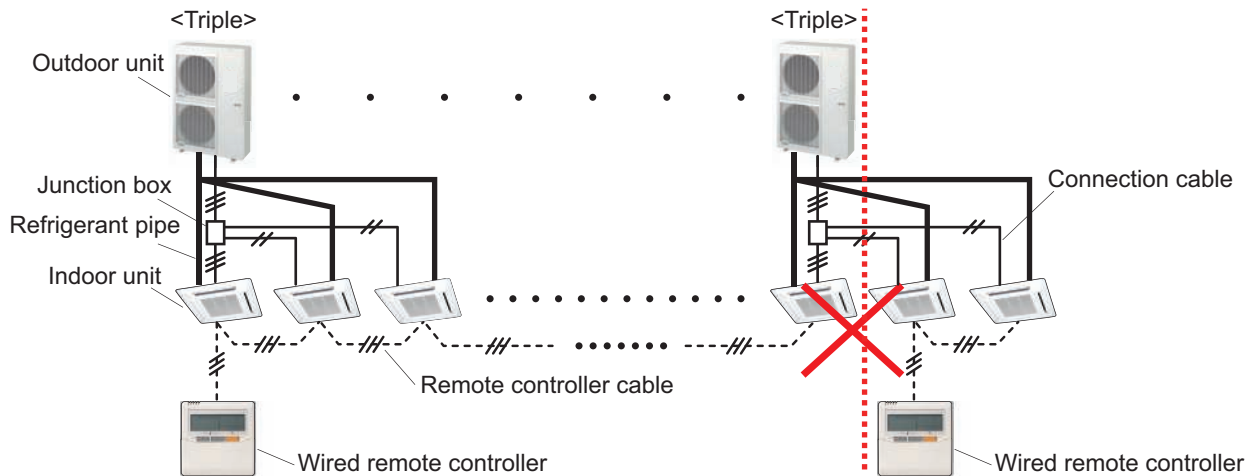

NOTE: Do not separate the remote controller group in the same refrigerant circuit.

5. System setting

5-1. Indoor unit setting

Setting			Setting range	Setting method
Set A	Indoor unit Primary/Secondary	○	"00" or "01"	Refer to "Function settings " on page 261. (Function number: 51)
Set B	Refrigerant circuit address	●	"00" to "15"	Refer to "Function settings " on page 261. (Function number: 02)
Set C	Remote controller address	○	"00" to "15"*	Refer to "Function settings " on page 261. (DIP switch setting)

NOTES:

- : Setting is required.
- : By a case, setting is required.
- *: Set the remote controller address in the order of "00", "01", "02",..., "15". (Blank is not allowed).

■ Twin type

• Connection example 1

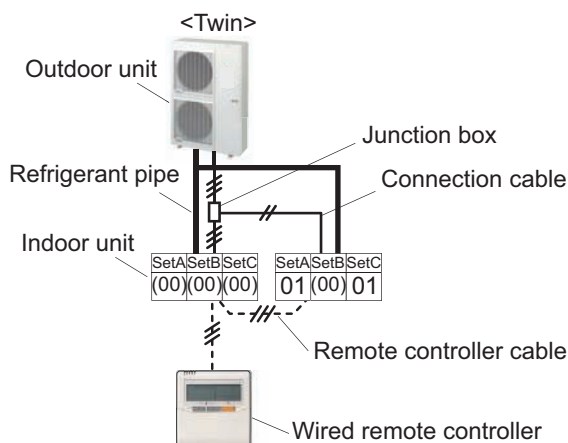

• Connection example 2

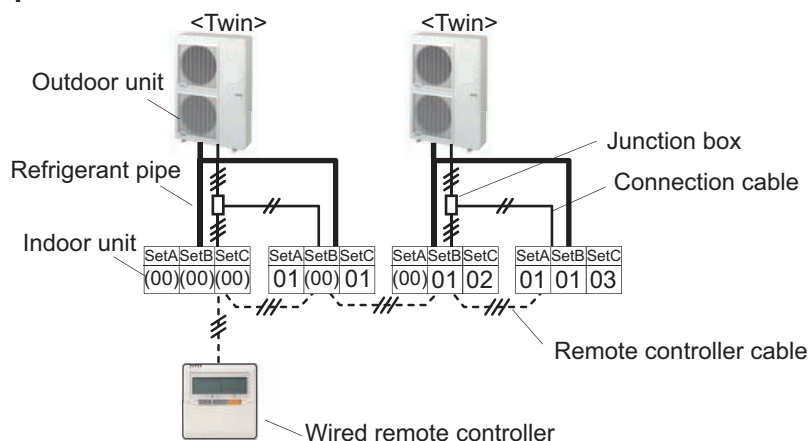

NOTE: (00) is factory setting.

Triple type

- Connection example 1

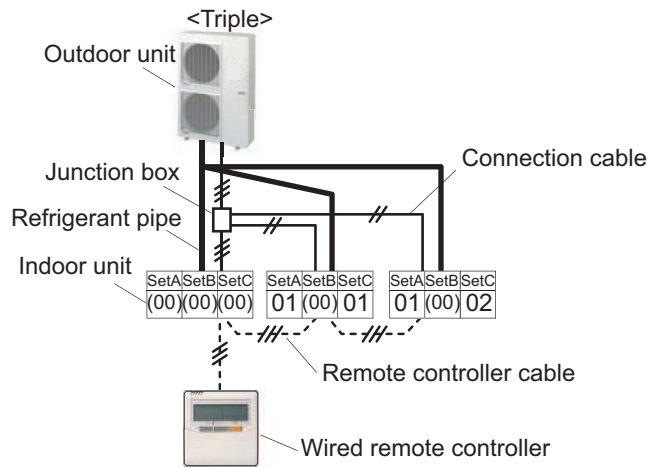

- Connection example 2

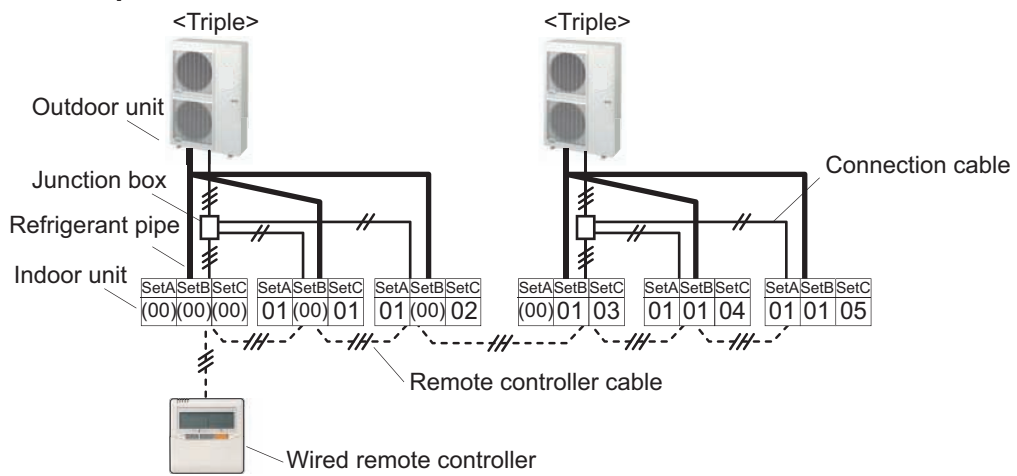

NOTE: (00) is factory setting.

Double twin type

Connection example 1

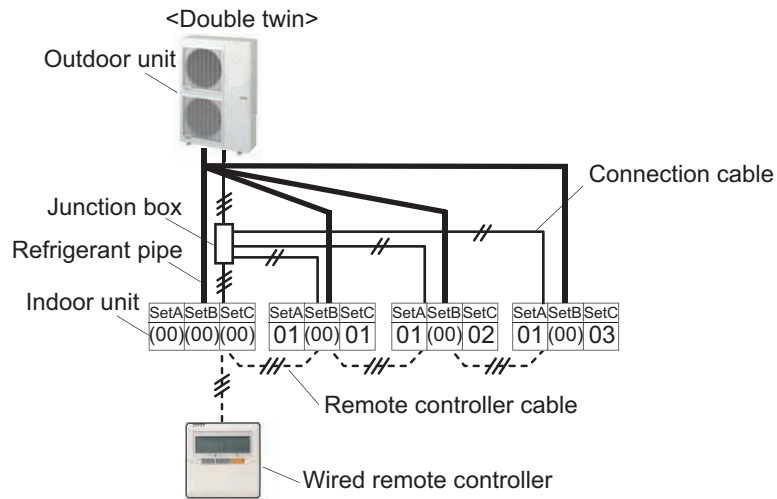

Connection example 2

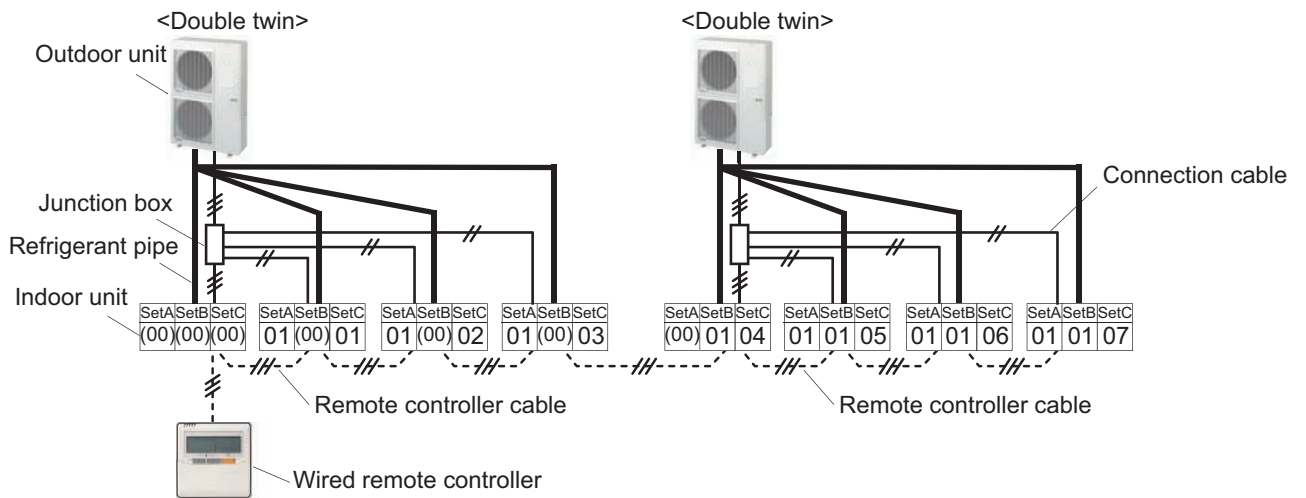

NOTE: (00) is factory setting.

Mixed

• Connection example 1

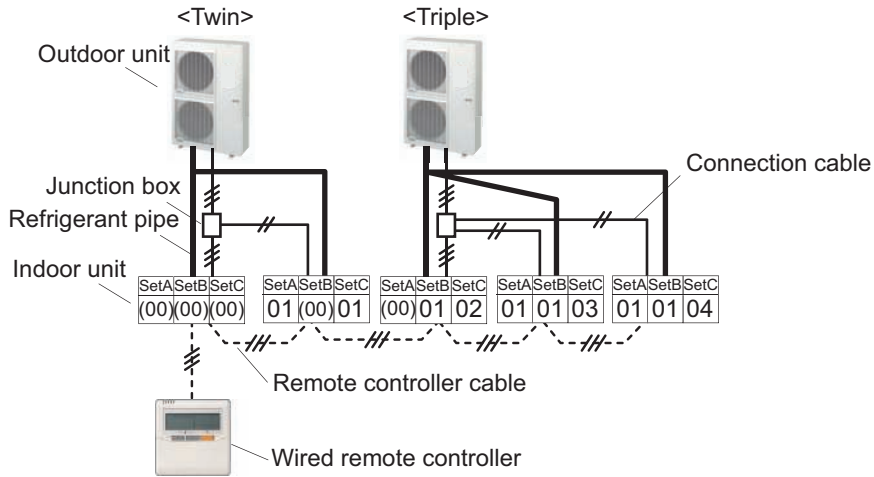

• Connection example 2

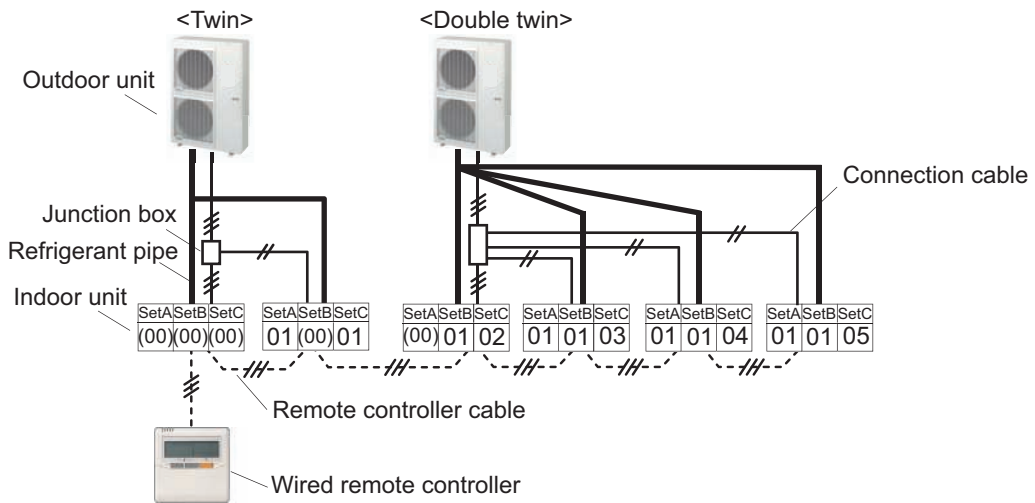

• Connection example 3

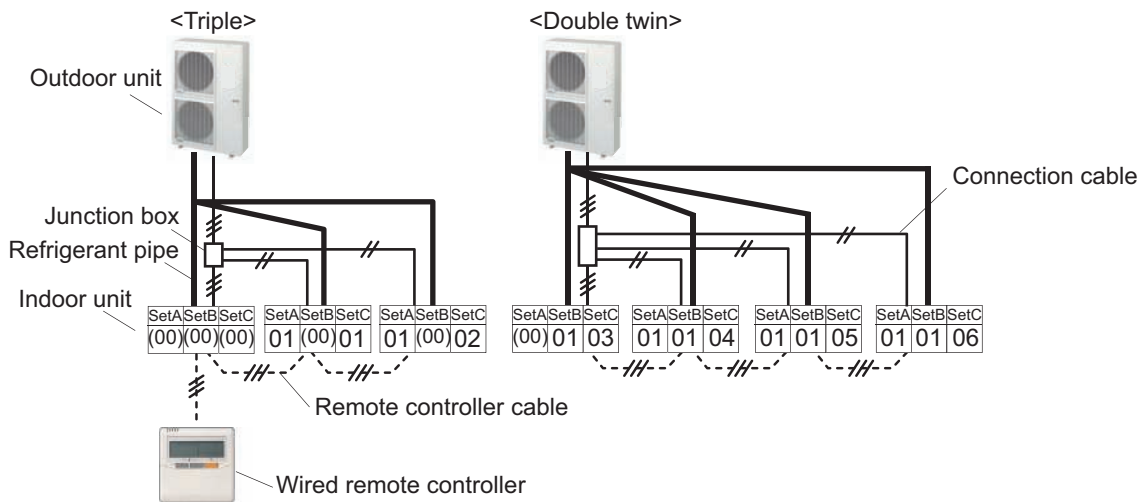

NOTE: (00) is factory setting.

6. External input and output

6-1. Indoor unit

Connector		Input	Output	Remarks
Other than high static pressure duct type	High static pressure duct type			
CN102	CN114	Control (Operation/Stop or Forced stop)	—	For details, refer to external input and output settings.
CN103	CN115	—	Operation status	
CN6	CN14	—	Fresh air control	
CN10 (Duct only)	CN15	—	Auxiliary heater	

■ Correspondence list

Name of types	Model	External input	External output		
		Control (Operation/Stop or Forced stop)	Operation status	Fresh air control	Auxiliary heater
Compact cassette	18	●	●	●	—
	22	●	●	●	—
	24	●	●	●	—
Cassette	30	●	●	●	—
	36	●	●	●	—
	45	●	●	●	—
Slim duct	18	●	●	●	●
Duct	22	●	●	●	●
	24	●	●	●	●
	30	●	●	●	●
	36	●	●	●	●
	45	●	●	●	●
Floor/Ceiling	18	●	●	—	—
	22	●	●	—	—
	24	●	●	—	—
Ceiling	30	●	●	●	—
	36	●	●	●	—
	45	●	●	●	—

External input

- “Operation/Stop” mode or “Forced stop” mode can be selected with function setting of indoor unit.
- A twisted pair cable (22AWG) should be used. Maximum length of cable is 150 m.
- The wire connection should be separate from the power cable line.

Control input (Operation/Stop or Forced stop)

Indoor unit type	Connector
Compact cassette	CN102
Cassette	
Slim duct	
Duct	
Floor/Ceiling	CN102
Ceiling	CN14

The air conditioner can be remotely operated by means of the following on-site work.

Operation is started at the following contents by adding the contact input of a commercial on/off switch to a connector on the external control PCB and turning it on.

Unit operation	Initial setting after power is on	Starting mode other than initial setting
Operation mode	Auto changeover	Mode at previous operation
Set temperature	24 °C	Temperature at previous operation
Airflow mode	AUTO	Mode at previous operation
Air direction (swing)	Standard air direction (swing: off)	Air direction at previous operation

• **Circuit diagram example**

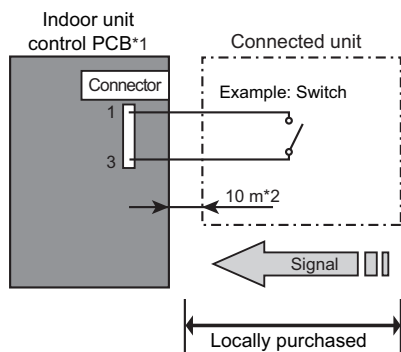

- Contact capacity: DC 24 V or more, 10 mA or more.
- *1: PCB of Communication kit is used for wall mounted type .
- *2: Make the distance from the PCB to the connected unit within 10 m.
- Use non-polar relays and switches.

Indoor unit type	1-pin (Polarity)	3-pin (Polarity)
Compact cassette and Cassette	-	+
Slim duct and Duct	-	+
Floor/Ceiling	-	+
Ceiling	-	+

– When function setting is "Operation/Stop" mode

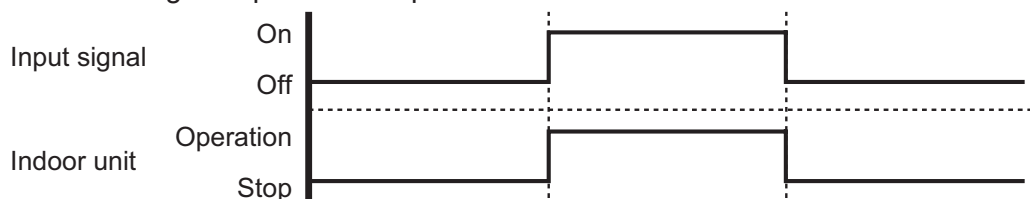

– When function setting is "Forced stop" mode

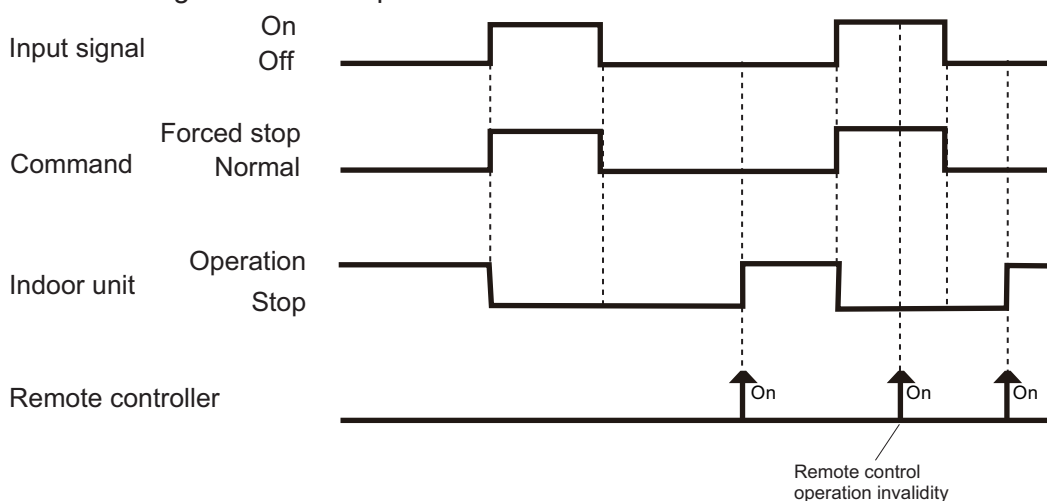

• **Optional part**

Indoor unit type	Part name	Model name
Compact cassette	External connect kit	UTY-XWZX
Cassette		UTY-XWZX
Slim duct		UTD-ECS5A
Duct		UTD-ECS5A
Floor/Ceiling		UTY-XWZX
Ceiling		UTY-XWZX

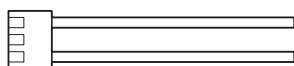

UTY-XWZX



UTD-ECS5A

External output

Use an external output cable with appropriate external dimension, depending on the number of cables to be installed.

Operation status output

Indoor unit type	Connector
Compact cassette	CN103
Cassette	
Slim duct	
Duct	
Floor/Ceiling	
Ceiling	CN20

Air conditioner operation status signal can be output.

Circuit diagram example

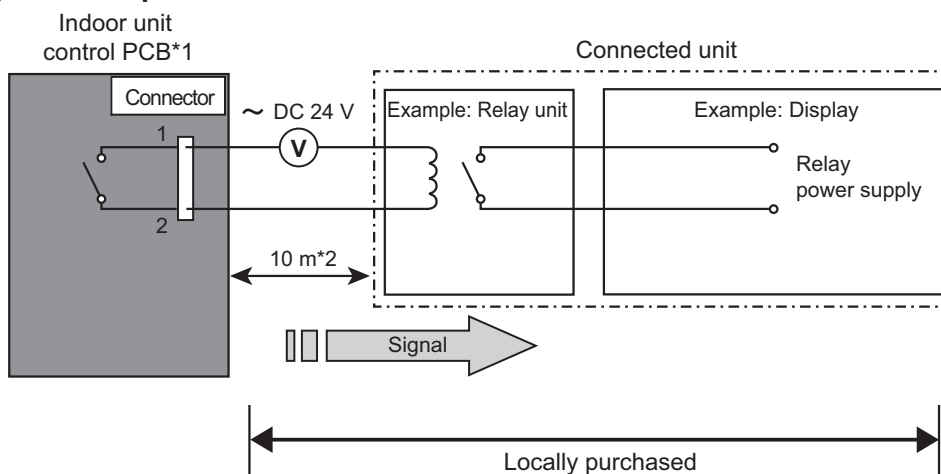

- *1: PCB of communication kit is used for wall mounted type
- *2: Make the distance from the PCB to the connected unit within 10 m.
- Relay spec: Max. DC 24 V, 10 mA to less than 500 mA.

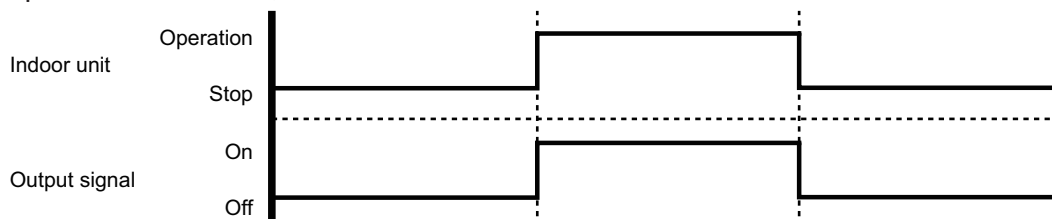

Optional part

Indoor unit type	Part name	Model name
Compact cassette	External connect kit	UTY-XWZX
Cassette		
Slim duct		UTD-ECS5A
Duct		
Floor/Ceiling		
Ceiling		UTY-XWZX

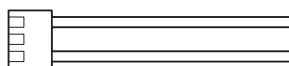

UTY-XWZXZ5

● Fresh air control output

Indoor unit type	Connector
Compact cassette	CN6
Cassette	CN6
Slim duct	CN6
Duct	CN6
Floor/Ceiling	—
Ceiling	—

Signal linked to air conditioner indoor fan on can be output.

* However, signal becomes off during cold air prevention control operation.

• Circuit diagram example

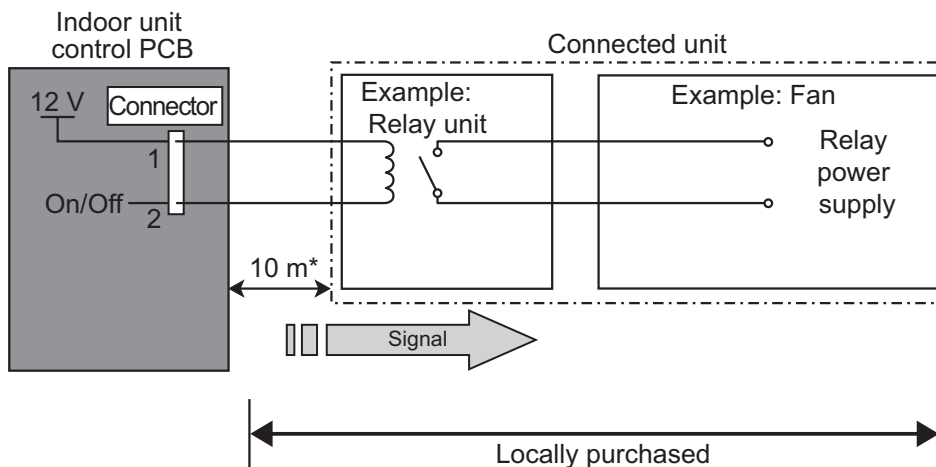

- *: Make the distance from the PCB to the connected unit within 10 m.
- Relay spec.: Rated DC 12 V, 50 mA to less.

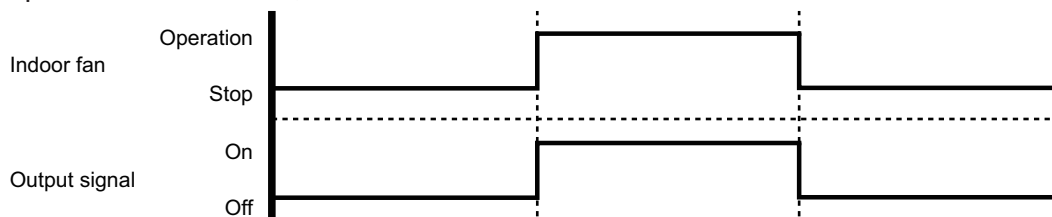

• Optional part

Indoor unit type	Part name	Model name
Compact cassette	Fresh air intake kit	UTZ-VXAA*
Cassette	Fresh air intake kit	UTZ-VXAA*
Slim duct	External control set	UTD-ECS5A
Duct	External control set	UTD-ECS5A
Floor/Ceiling	—	—
Ceiling	—	—



*: This wire is included in fresh air intake kit (UTZ-VXAA).

● Auxiliary heater output

Indoor unit type	Connector
Compact cassette	—
Cassette	—
Slim duct	CN10
Duct	CN10
Floor/Ceiling	—
Ceiling	—

Signal is output from connector when indoor fan and compressor turn on under heating operation.

*Signal output performance specifications are as shown as follows:

Example: When Set Temperature (T_s) is 22 °C

- and room temperature (T_r) increase above 12 °C, signal output is on.
- and room temperature (T_r) increase above 21 °C, signal output is off.
- and room temperature (T_r) decrease below 19 °C, signal output is on.
- and room temperature (T_r) decrease below 10 °C, signal output is off.

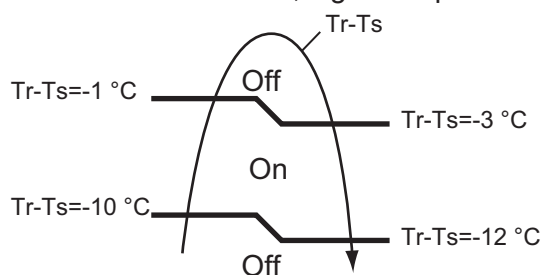

- **Fan delay setting (JM3)**

This is used to continue indoor unit fan operation for 1 minute after thermostat "Off" in heating mode.

1 minute delay control set by cutting jumper wire on PCB (For details, refer to ["Function settings"](#) on page 261).

• **Circuit diagram example**

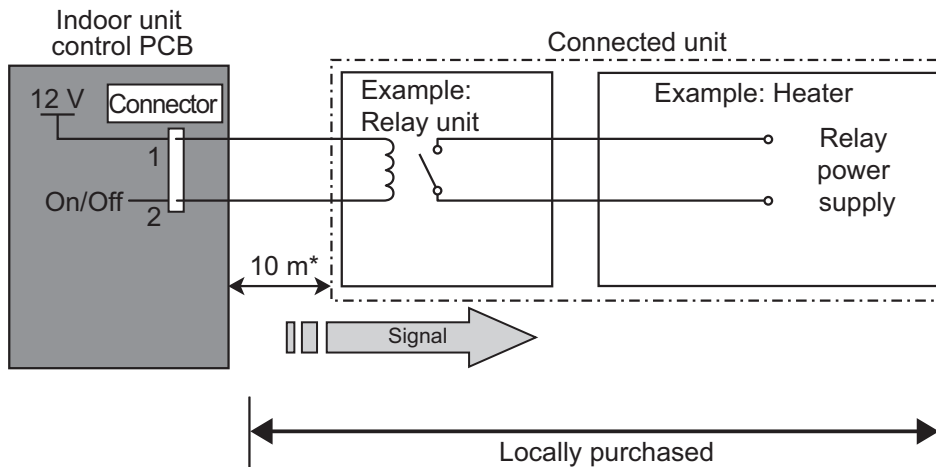

- Relay spec.: Rated DC 12 V, 50 mA to less.
- *: Make the distance from the PCB to the connected unit within 10 m.

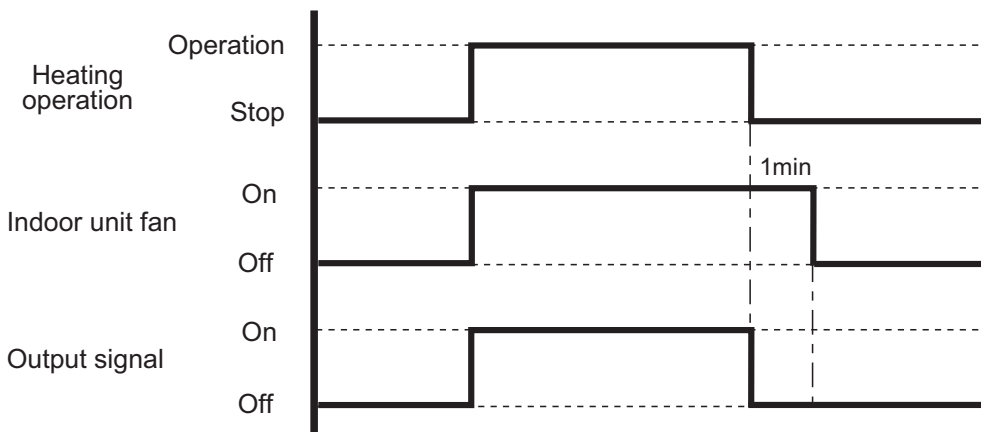

CAUTION

- Locate an external heater between the indoor unit and the outlet.

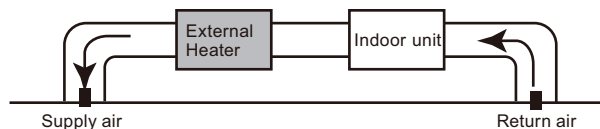

- Be sure to use delay control of a fan.

• **Optional part**

Indoor unit type	Part name	Model name
Compact cassette	—	—
Cassette	—	—
Slim duct	External control set	UTD-ECS5A
Duct		UTD-ECS5A
Floor/Ceiling	—	—
Ceiling	—	—



6-2. Outdoor unit

Connector	Input	Output	Remarks
CN131	Low noise mode	—	For details, refer to external input and output settings.
CN132	Peak cut mode	—	
CN136	—	Error status	
CN137	—	Compressor status	

External input

With using external input function, on/off status of “Low noise mode” and “Peak cut mode” can be specified by the external signal.

Low noise mode

In following condition, the operating noise of the outdoor unit reduces comparing from the one in normal operating condition:

The air conditioner is set to the “Low noise mode” when closing the contact input of a commercial timer or on/off switch to a connector on the control PCB of the outdoor unit.

NOTE: Product performance may drop depending on some conditions such as the outdoor temperature.

Circuit diagram example (CN131)

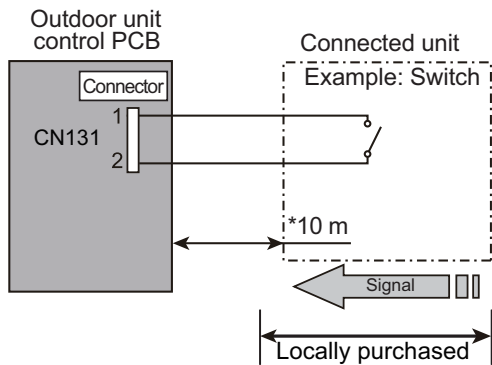

- Contact capacity: DC 24 V or more, 10 mA or more.
- *: Make the distance from the PCB to the connected unit within 10 m.
- Construct a circuit as shown in this figure with using optional parts mentioned below.
- Input signal: On in “Low noise mode”
- Input signal: Off in normal operation
- To set the level of “Low noise mode”, refer to ["Low noise mode"](#) on page 282.

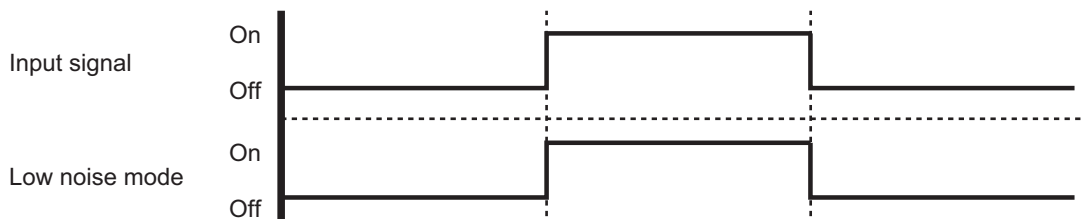

Optional part

Part name	Model name	Exterior
External connect kit	UTY-XWZXZ3	

● Peak cut mode

By performing following on-site work, operation that suppresses the current value can be enabled: The air conditioner is set to the “Peak cut mode” when closing the contact input of a commercial timer or on/off switch to a connector on the control PCB of the outdoor unit.

• Circuit diagram example (CN132)

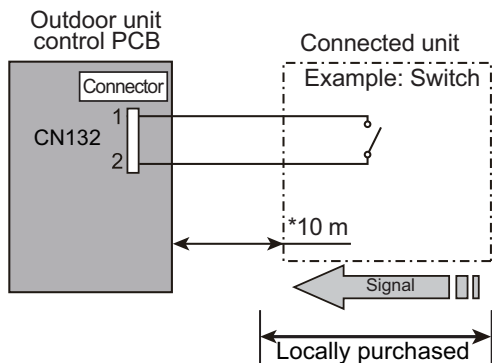

- Contact capacity: DC 24 V or more, 10 mA or more.
- *: Make the distance from the PCB to the connected unit within 10 m.
- Construct a circuit as shown in this figure with using optional parts mentioned below.
- Input signal: On in “Peak cut mode”
- Input signal: Off in normal operation
- To set the level of “Peak cut mode”, refer to ["Peak cut mode"](#) on page 283.

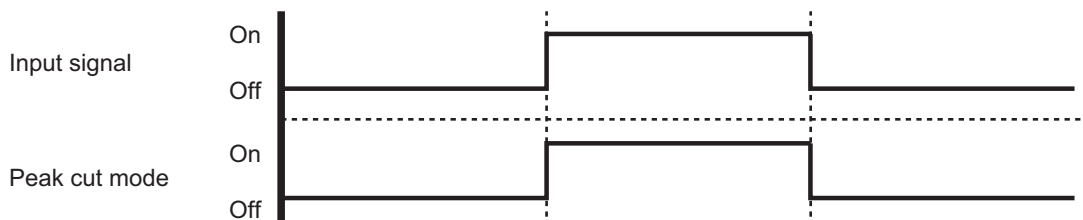

• Optional part

Part name	Model name	Exterior
External connect kit	UTY-XWZXZ3	

External output

With using external output function, some status signals are transmitted to the control PCB, and the related LED lamp indicates the status of this product.

Error status output

Signal on air conditioner error status is generated when a malfunction occurs.

Circuit diagram example (CN136)

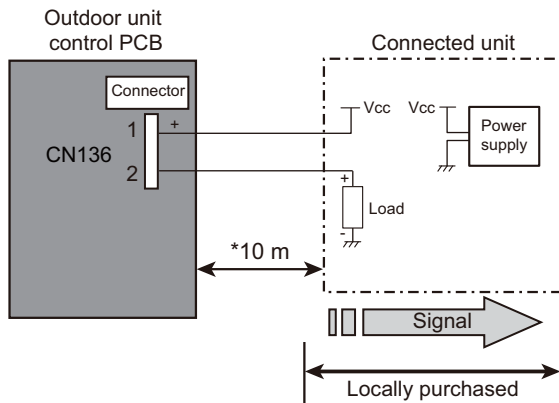

- 1: Power supply
Voltage (Vcc): DC 24 V or less
- 2: Load
DC 500 mA or less
- *: Make the distance from the PCB to the connected unit within 10 m.

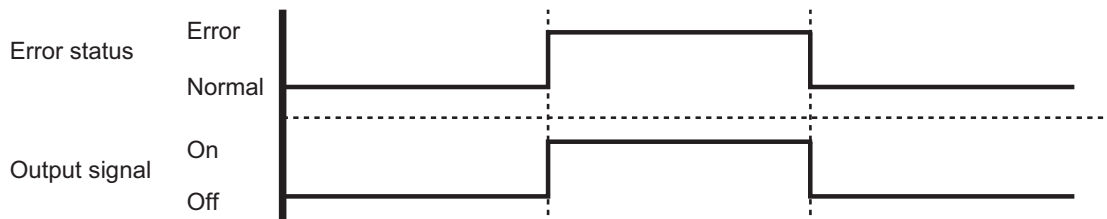

Optional part

Part name	Model name	Exterior
External connect kit	UTY-XWZXZ3	

● Compressor status output

Signal on compressor operation status is generated when the compressor is running.

• Circuit diagram example (CN137)

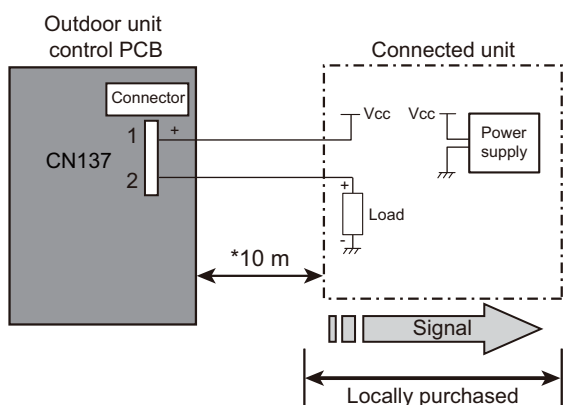

- 1: Power supply
Voltage (Vcc): DC 24 V or less
- 2: Load
DC 500 mA or less
- *: Make the distance from the PCB to the connected unit within 10 m.

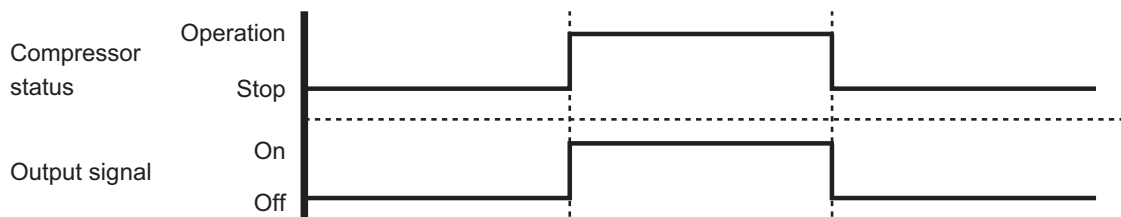

• Optional part

Part name	Model name	Exterior
External connect kit	UTY-XWZXZ3	

7. Remote controller

7-1. Wireless remote controller (AR-RAH2E/AR-RAH1E)

Overview

AR-RAH2E

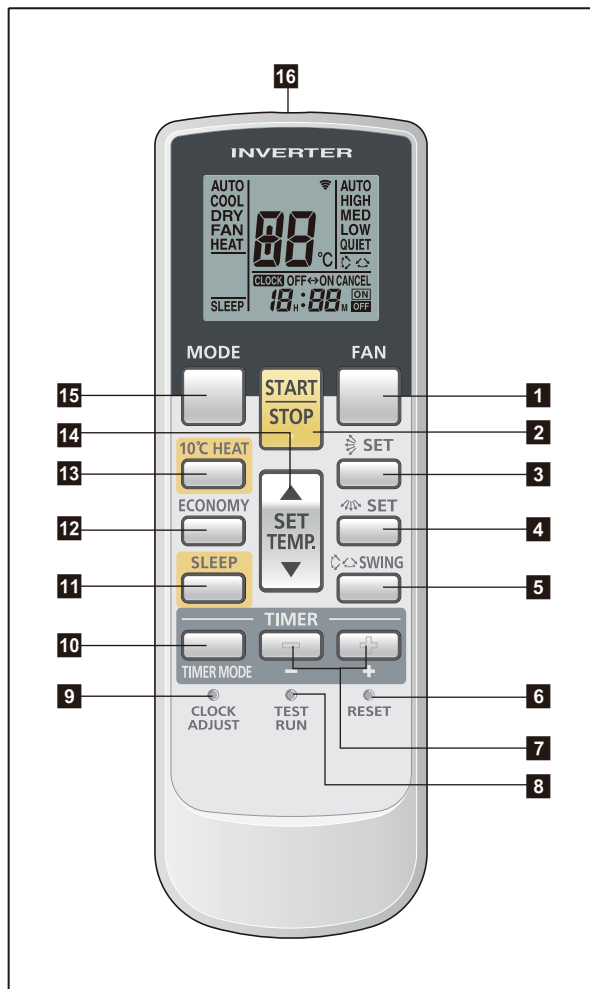

Display panel

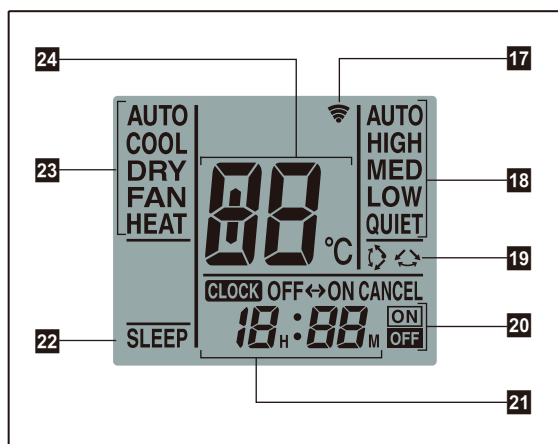

NOTE: Functions may differ by type of the indoor unit. For details, refer to the operation manual.

1 FAN button

Selects the fan speed (AUTO, HIGH, MED, LOW, and QUIET).

2 START/STOP button

Starts and stops operation.

3 SET button (vertical)

Adjusts the vertical airflow direction.

4 SET button (horizontal)

Adjusts the horizontal airflow direction.

5 SWING button

Sets the automatic swing operation and selects swing mode (Up/down, Left/right, Up/down/left/right, and Stop swing).

6 RESET button

Used when replacing batteries.

7 Timer set (- / +) button

Sets the current time and on-off time.

8 TEST RUN button

Only used for the initial test in the unit installation.

9 CLOCK ADJUST button

10 TIMER MODE button

Selects the timer mode (off timer, on timer, program timer, and timer reset).

11 SLEEP button

12 ECONOMY button

13 10 °C HEAT button

14 SET TEMP. (temperature) (▲ / ▼) button

- Sets desired temperature.
- Sets remote controller custom code.

15 MODE button

- Switches operation mode (AUTO, COOL, DRY, FAN, and HEAT).
- Starts/ends the remote controller custom code (max. 4 types) change.

16 Signal transmitter

17 Signal transmit indicator

18 Fan speed indicator

19 Swing indicator

20 Timer mode indicator

21 Clock indicator

22 Sleep indicator

23 Operating mode indicator

24 Temperature indicator

● AR-RAH1E

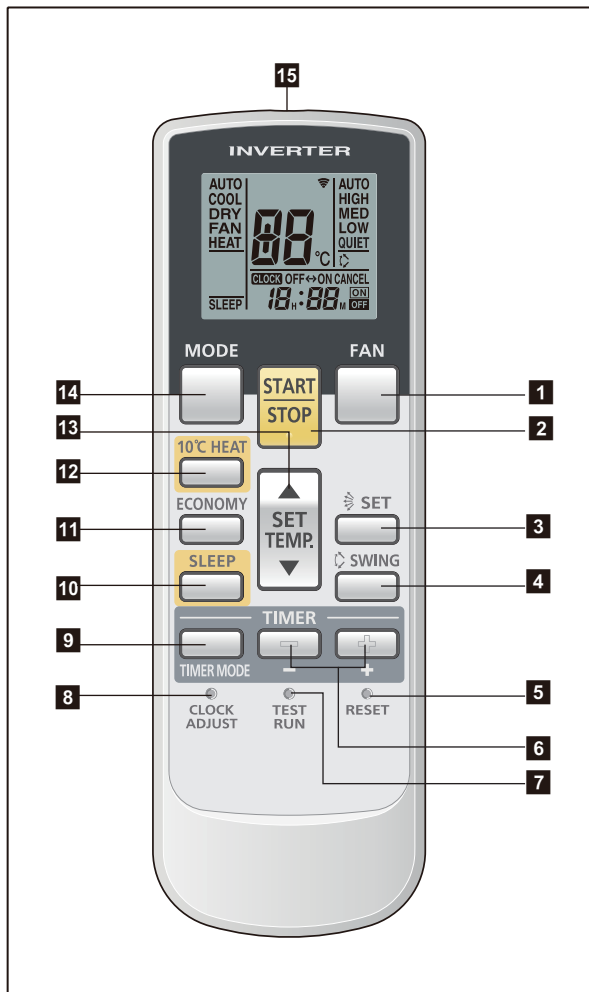

Display panel

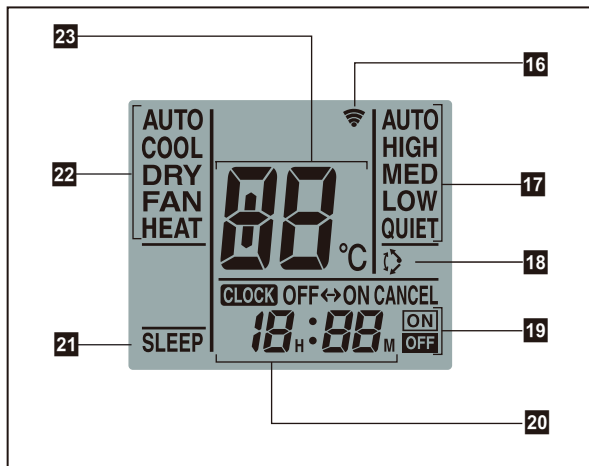

NOTE: Functions may differ by type of the indoor unit. For details, refer to the operation manual.

1 FAN button

Selects the fan speed (AUTO, HIGH, MED, LOW, and QUIET).

2 START/STOP button

Starts and stops operation.

3 SET button (vertical)

Adjusts the vertical airflow direction.

4 SWING button

Sets the automatic swing operation and selects swing mode (Left/right, Stop swing).

5 RESET button

Used when replacing batteries.

6 Timer set (- / +) button

Sets the current time and on-off time.

7 TEST RUN button

Only used for the initial test in the unit installation.

8 CLOCK ADJUST button

9 TIMER MODE button

Selects the timer mode (off timer, on timer, program timer, and timer reset).

10 SLEEP button

11 ECONOMY button

12 10 °C HEAT button

13 SET TEMP. (temperature) (▲ / ▼) button

- Sets desired temperature.
- Sets remote controller custom code.

14 MODE button

- Switches operation mode (AUTO, COOL, DRY, FAN, and HEAT).
- Starts/ends the remote controller custom code (max. 4 types) change.

15 Signal transmitter

16 Signal transmit indicator

17 Fan speed indicator

18 Swing indicator

19 Timer mode indicator

20 Clock indicator

21 Sleep indicator

22 Operating mode indicator

23 Temperature indicator

■ Specifications

● Controller

Unit: mm

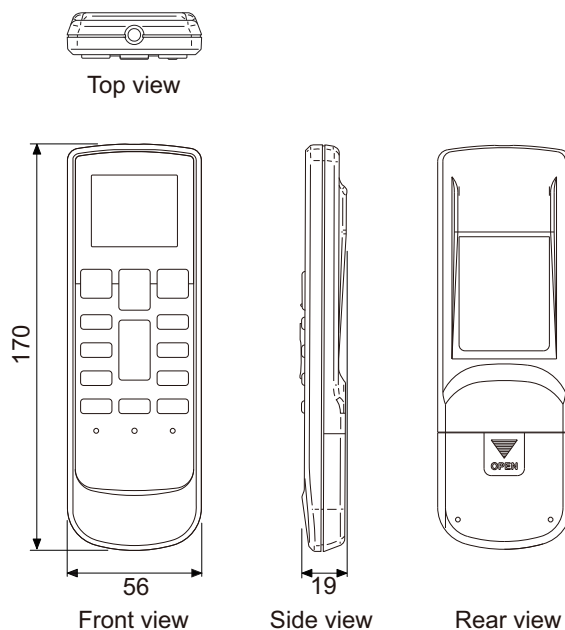

Size (H × W × D)	mm	170 × 56 × 19
Weight	g	85 (without batteries)

NOTE: Actual number of buttons might be different from the figure above.

● Holder

Unit: mm

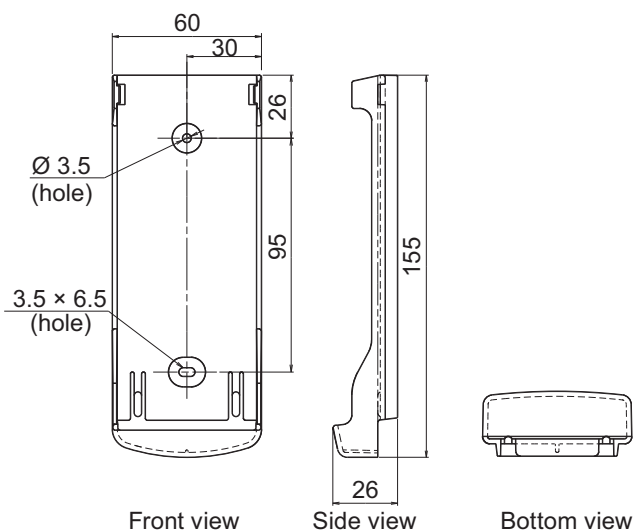

Size (H × W × D)	mm	155 × 60 × 26
Weight	g	28

7-2. IR receiver kit with Wireless remote controller (UTY-LRHGA2: Optional part)

Overview

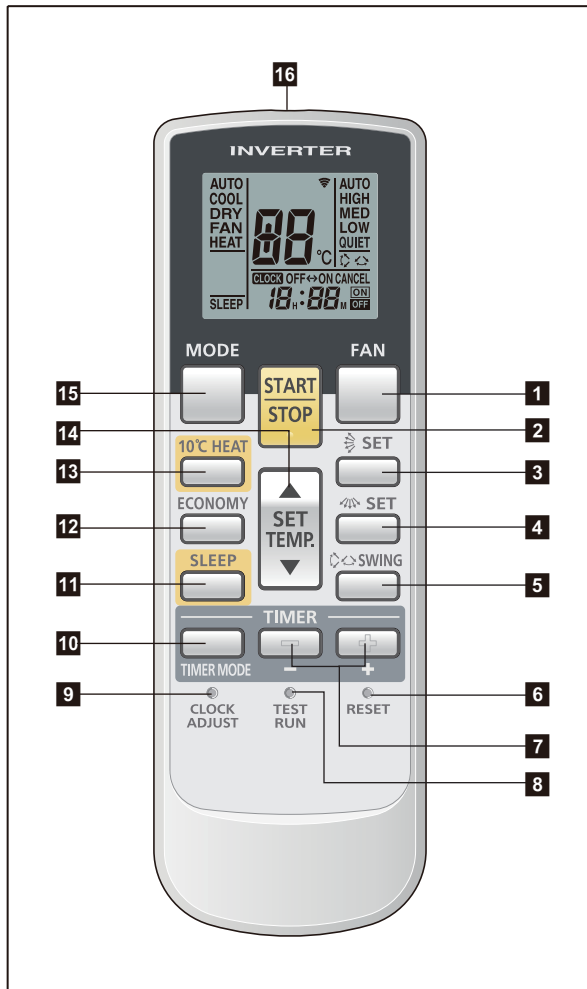

Display panel

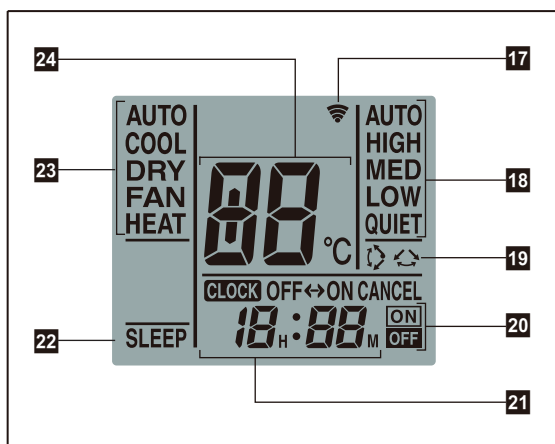

NOTE: Functions may differ by type of the indoor unit. For details, refer to the operation manual.

1 FAN button

Selects the fan speed (AUTO, HIGH, MED, LOW, and QUIET).

2 START/STOP button

Starts and stops operation.

3 SET button (vertical)

Adjusts the vertical airflow direction.

4 SET button (horizontal)

Adjusts the horizontal airflow direction.

5 SWING button

Sets the automatic swing operation and selects swing mode (Up/down, Left/right, Up/down/left/right, and Stop swing).

6 RESET button

Used when replacing batteries.

7 Timer set (- / +) button

Sets the current time and on-off time.

8 TEST RUN button

Only used for the initial test in the unit installation.

9 CLOCK ADJUST button

Used for adjusting the clock.

10 TIMER MODE button

Selects the timer mode (off timer, on timer, program timer, and timer reset).

11 SLEEP button

Pressed to select sleep timer.

12 ECONOMY button

13 10 °C HEAT button

14 SET TEMP. (temperature) (▲ / ▼) button

- Sets desired temperature.
- Sets remote controller custom code.

15 MODE button

- Switches operation mode (AUTO, COOL, DRY, FAN, and HEAT).
- Starts/ends the remote controller custom code (max. 4 types) change.

16 Signal transmitter

17 Signal transmit indicator

18 Fan speed indicator

19 Swing indicator

20 Timer mode indicator

21 Clock indicator

22 Sleep indicator

23 Operating mode indicator

24 Temperature indicator

■ Specifications

● Controller

Unit: mm

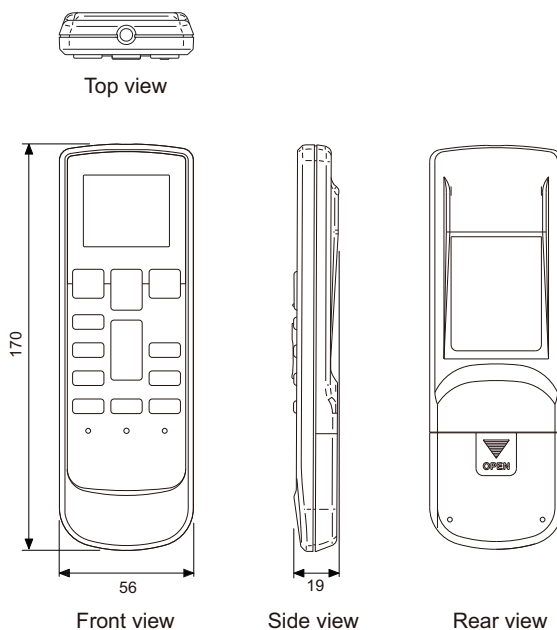

Size (H × W × D)	mm	170 × 56 × 19
Weight	g	85 (without batteries)

● Holder

Unit: mm

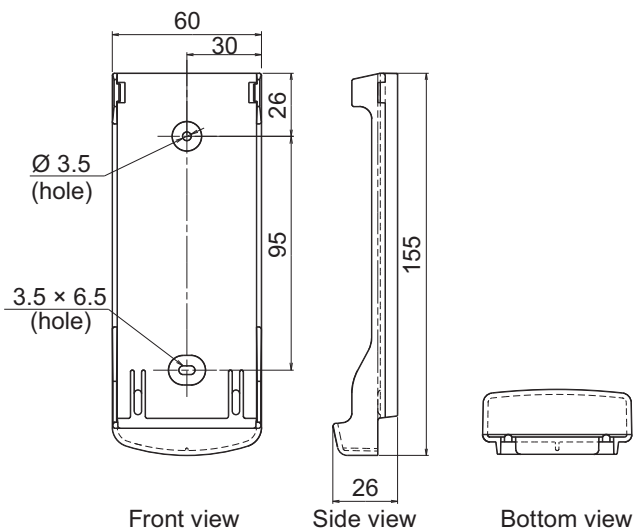

Size (H × W × D)	mm	154.7 × 60.4 × 26.2
Weight	g	28

● IR receiver

Unit: mm

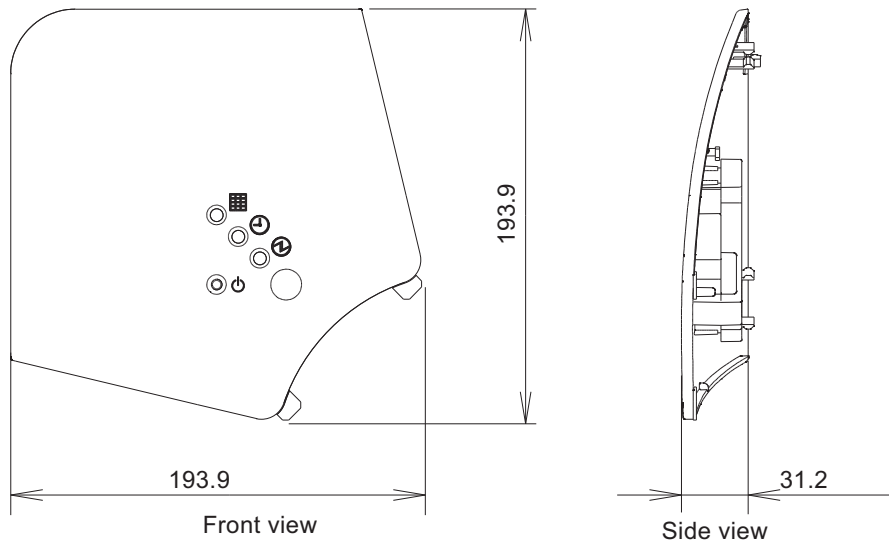

Size (H × W × D)	mm	193.9 × 193.9 × 31.2
Weight	g	140

7-3. IR receiver kit with Wireless remote controller (UTY-LRHGM: Optional part)

Overview

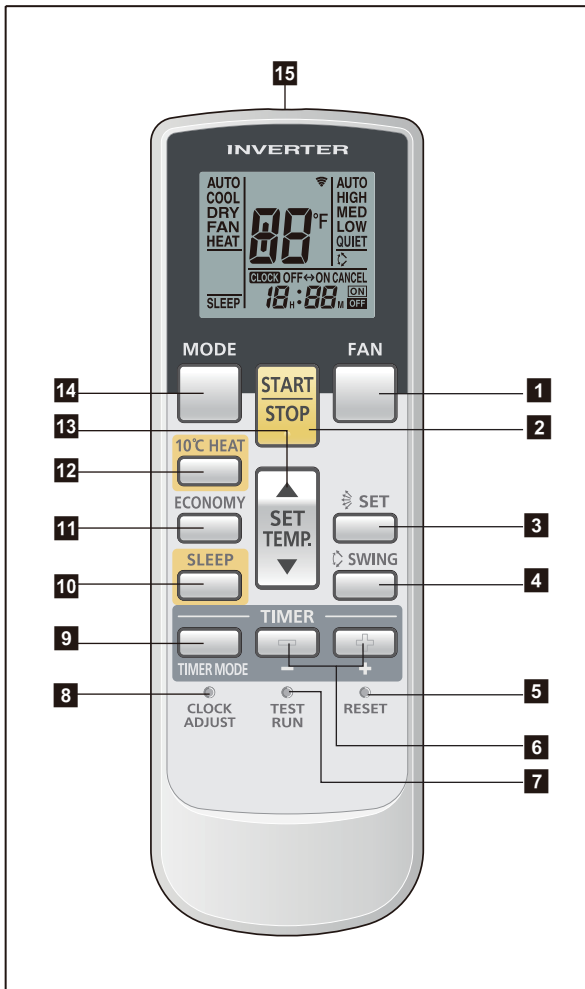

Display panel

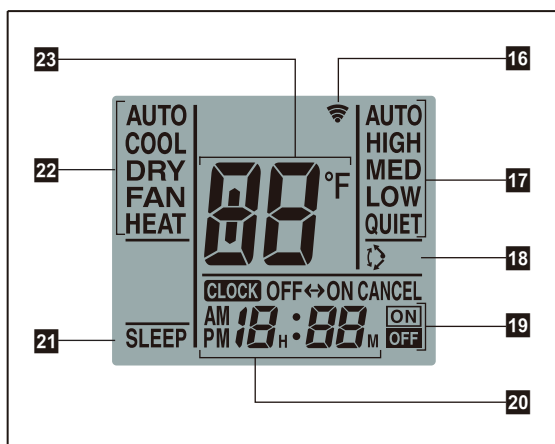

NOTE: Functions may differ by type of the indoor unit. For details, refer to the operation manual.

1 FAN button

Selects the fan speed (AUTO, HIGH, MED, LOW, and QUIET).

2 START/STOP button

Starts and stops operation.

3 SET button (vertical)

Adjusts the vertical airflow direction.

4 SWING button

Sets the automatic swing operation and selects swing mode (Up/down, Left/right, Up/down/left/right, and Stop swing).

5 RESET button

Used when replacing batteries.

6 Timer set (- / +) button

Sets the current time and on-off time.

7 TEST RUN button

Only used for the initial test in the unit installation.

8 CLOCK ADJUST button

Used for adjusting the clock.

9 TIMER MODE button

Selects the timer mode (off timer, on timer, program timer, and timer reset).

10 SLEEP button

Pressed to select sleep timer.

11 ECONOMY button

12 10 °C HEAT button

13 SET TEMP. (temperature) (▲ / ▼) button

- Sets desired temperature.
- Sets remote controller custom code.

14 MODE button

- Switches operation mode (AUTO, COOL, DRY, FAN, and HEAT).
- Starts/ends the remote controller custom code (max. 4 types) change.

15 Signal transmitter

16 Signal transmit indicator

17 Fan speed indicator

18 Swing indicator

19 Timer mode indicator

20 Clock indicator

21 Sleep indicator

22 Operating mode indicator

23 Temperature indicator

■ Specifications

● Controller

Unit: mm

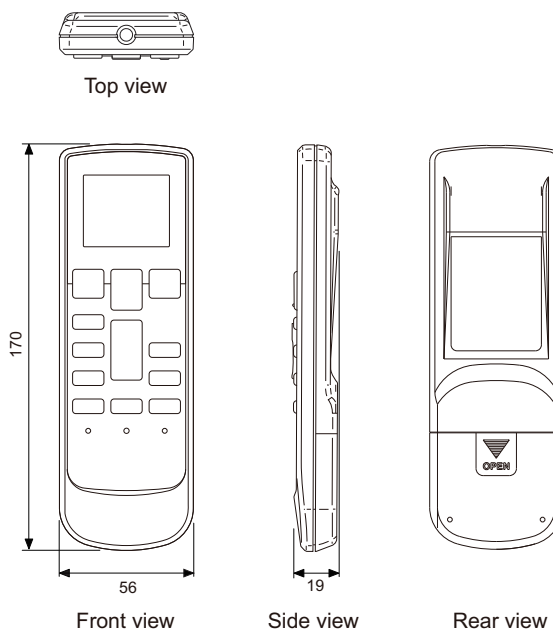

Size (H × W × D)	mm	170 × 56 × 19
Weight	g	85 (without batteries)

● Holder

Unit: mm

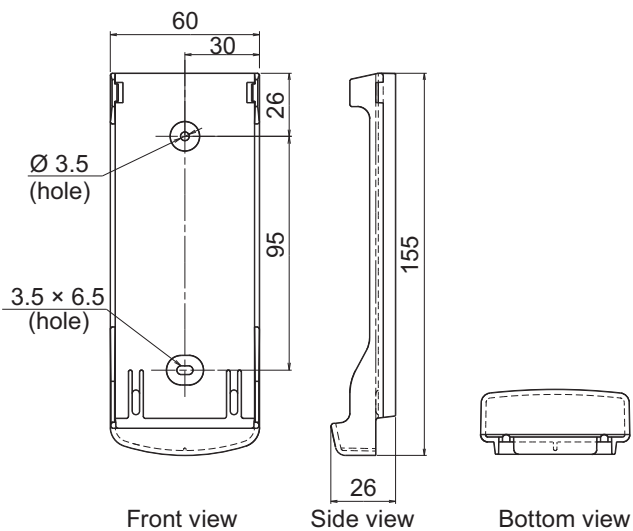

Size (H × W × D)	mm	154.7 × 60.4 × 26.2
Weight	g	28

● IR receiver

Unit: mm

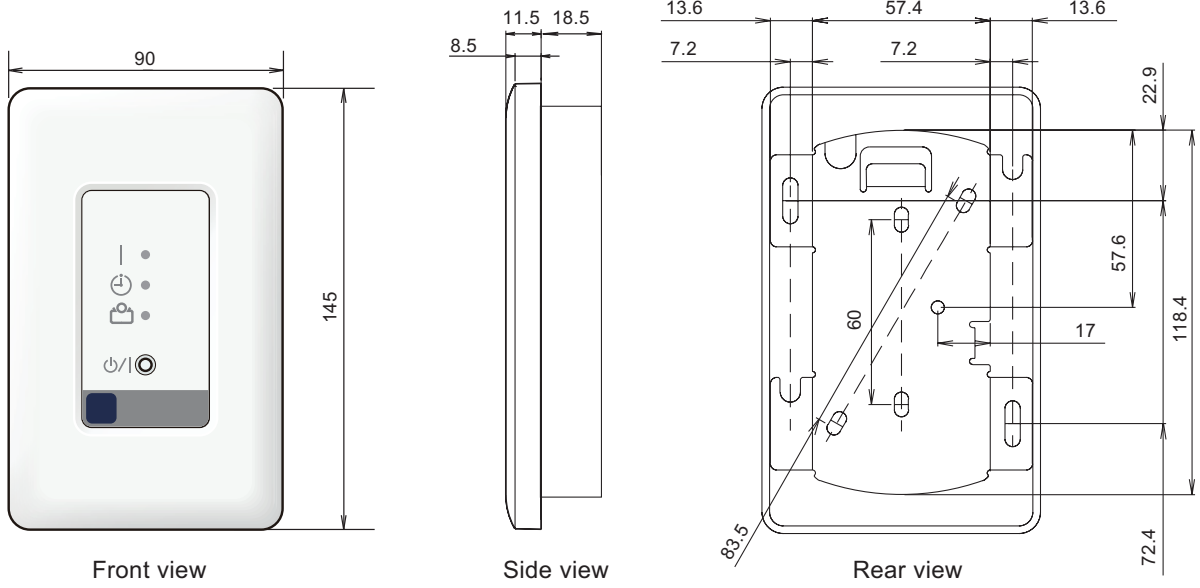

Size (H × W × D)	mm	145 × 90 × 30
Weight	g	150

SYSTEM DESIGN

SYSTEM DESIGN

7-4. Wired remote controller (UTY-RNNGM)



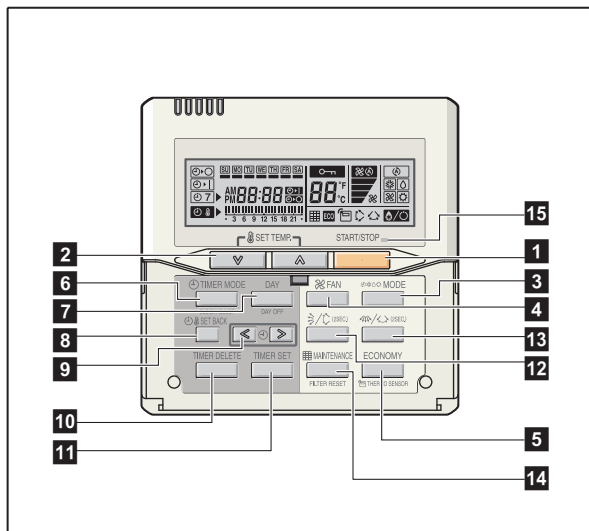



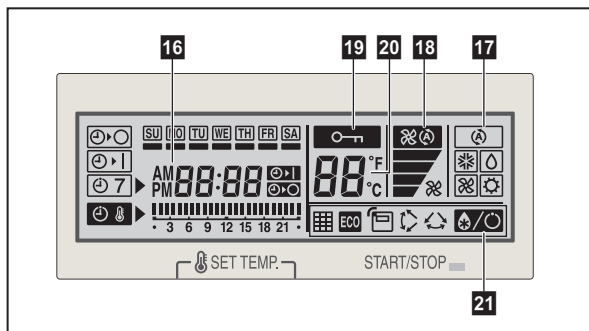









Overview



Display panel



NOTE: Functions may differ by type of the indoor unit. For details, refer to the operation manual.

- 1 START/STOP button**
Starts and stops operation.
- 2 SET TEMP. button**
Selects the setting temperature.
- 3 MODE button**
Selects the operating mode (AUTO , HEAT , FAN , COOL , and DRY ).
- 4 FAN button**
Selects the fan speed AUTO , QUIET , LOW , MED , and HIGH .
- 5 ECONOMY (THERMO SENSOR) button**
Turns the economy-efficient mode on and off.
- 6 TIMER MODE (CLOCK ADJUST) button**
Selects the timer mode (off timer, on timer, and weekly timer). Sets the current time.
- 7 DAY (DAY OFF) button**
Temporarily cancels one day timer.
- 8 SET BACK button**
Selects the set back timer.
- 9 Set time button**
Pressed to set time.
- 10 TIMER DELETE button**
Deletes the weekly timer schedule.
- 11 TIMER SET button**
Sets the date, hour, minute, and on-off time.
- 12 Vertical airflow direction and swing button**
Push for 2 seconds to change the swing mode.
- 13 Horizontal airflow direction and swing button**
Push for 2 seconds to change the swing mode.
- 14 FILTER RESET button**
- 15 Operation lamp**
Lights during operation and when the timer is on.
- 16 Timer and clock indicator**
- 17 Operation mode indicator**
- 18 Fan speed indicator**
- 19 Operation lock indicator**
- 20 Temperature indicator**
- 21 Function indicators**
 -  Defrost indicator
 -  Thermo sensor indicator
 -  Economy indicator
 -  Vertical swing indicator
 -  Horizontal swing indicator
 -  Filter indicator

System diagram

1 remote controller:

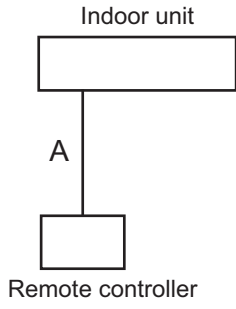

2 remote controllers:

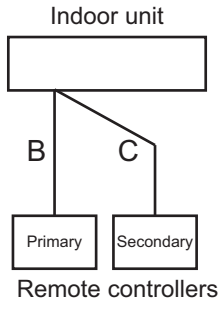

A, B, C: Remote controller cable
 $A \leq 500 \text{ m}; B + C \leq 500 \text{ m}$

Electrical wiring

1 remote controller:

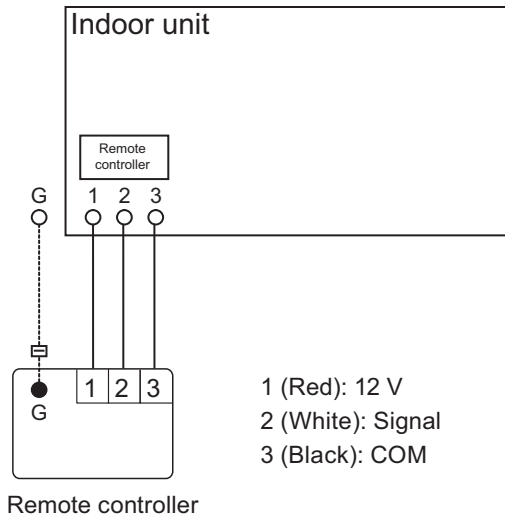

2 remote controllers:

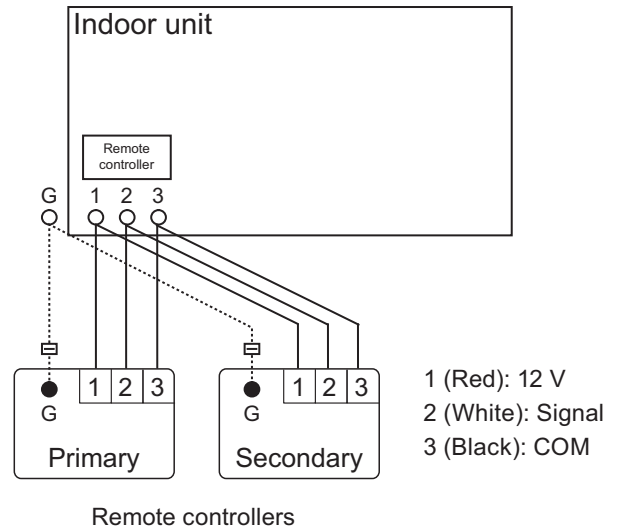

■ Specifications

Dimensions and other specifications on the wired remote controller are as follows.

Unit: mm		
	120	
		120
		18
	Front view	Side view
Size (H × W × D)	mm	120 × 120 × 18
Weight	g	160
Cable length (accessory)	m	10
Power	V	12

● Wiring specifications

Use	Cable size	Wire type	Remarks
Remote controller cable	0.33 mm ² (22 AWG)	Polar 3-core	Use sheathed PVC cable.

■ Installation

● Connection pattern

NOTE: Connection pattern is different according to type of Indoor unit.

Indoor unit type	Connection pattern
Compact cassette	Pattern A
Cassette	
Slim duct	
Duct	
Floor/Ceiling	
Ceiling	Pattern B

● Pattern A

Connect the end of remote controller cable directly to the exclusive terminal block.

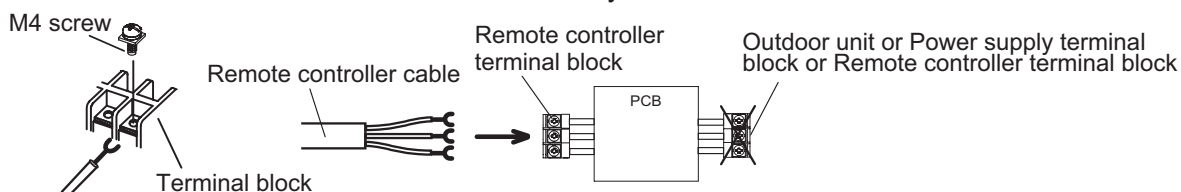

NOTE: It may be failed if it is connected to the outdoor unit or the terminal block for power supply.

● Pattern B

1. Modify the remote controller cable as follows:

- Use a tool to cut off the terminal on the end of the remote controller cable and then remove the insulation from the cut end of the cable as shown in following figure.
- Connect the remote controller cable and connecting cable as shown in following figure.
- Be sure to insulate the connection between the cables.

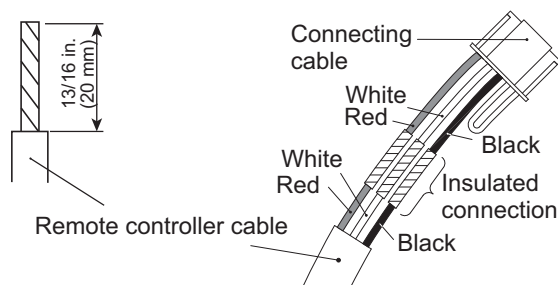

2. Connect the remote controller cable.

- Connect the cable made in step 1. to the indoor unit PCB.

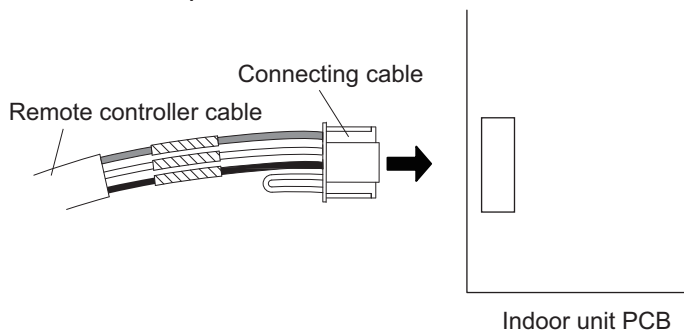

7-5. Wired remote controller (UTY-RVNGM: Optional part)

■ Overview

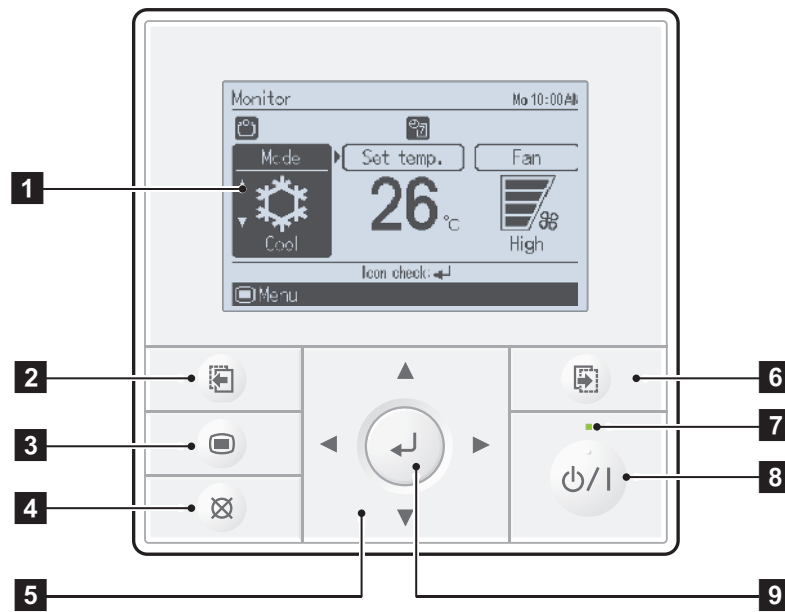

- 1** Display panel (with backlight)
- 2** Screen switch button (Left)
- 3** Menu button
- 4** Cancel button
- 5** Cursor button
- 6** Screen switch button (Right)
- 7** Power indicator
- 8** On/off button
- 9** Enter button

System diagram

1 remote controller:

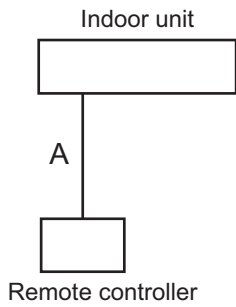

2 remote controllers:

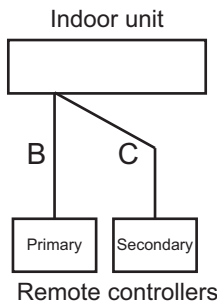

A, B, C: Remote controller cable
 $A \leq 500 \text{ m}; B + C \leq 500 \text{ m}$

Electrical wiring

1 remote controller:

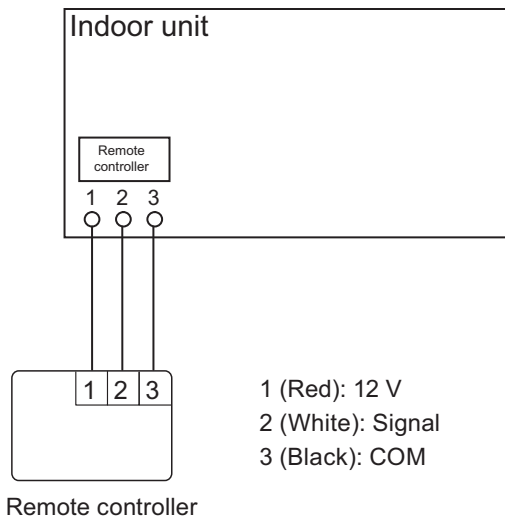

2 remote controllers:

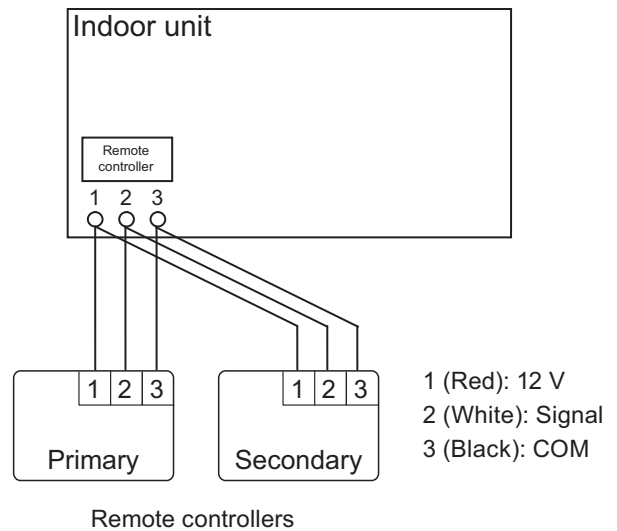

Controller combination

As for the combined usage of the controller, refer to following figures.

● Good

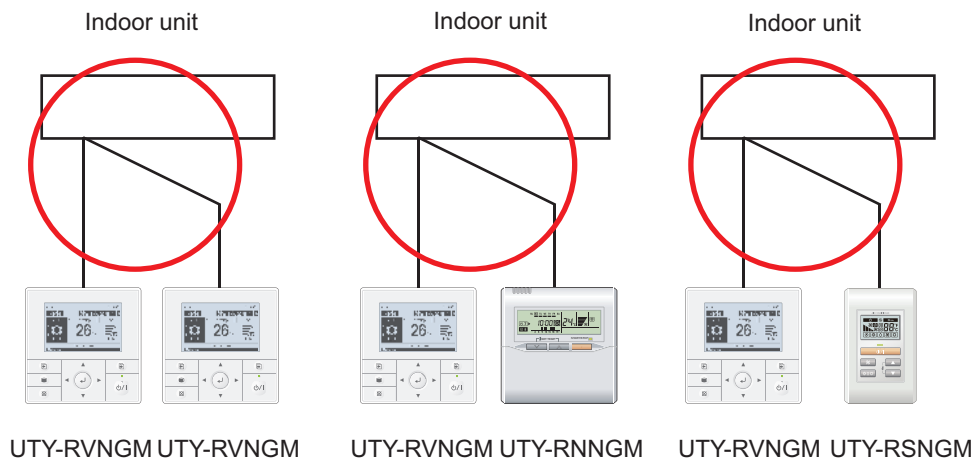

■ Specifications

Unit: mm

Size (H × W × D)	mm	120 × 120 × 21.3
Weight	g	220

● Wiring specifications

Use	Cable size	Wire type	Remarks
Remote controller cable	0.33 mm ²	Polar 3 core	Use sheathed PVC cable.

■ Installation (Remote control main unit)

Installation space:

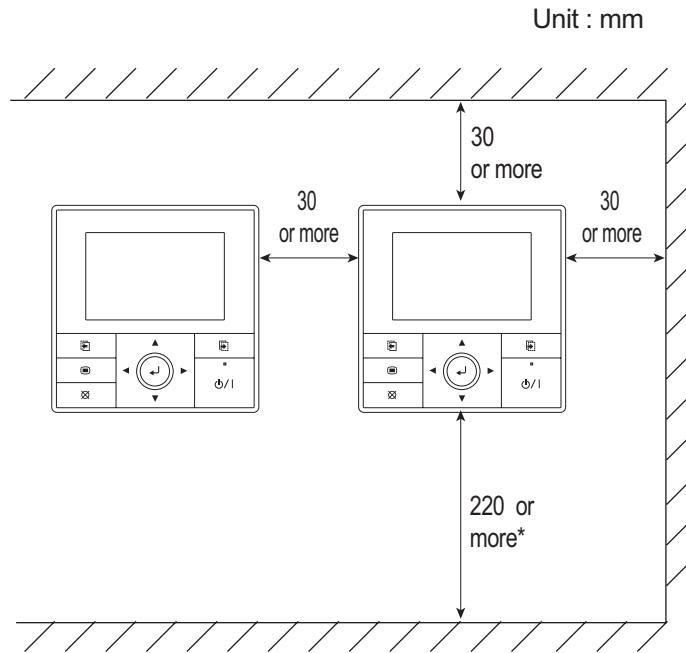

NOTE: Secure enough space where a flat-blade screwdriver to remove the case can be inserted.

Installation procedures:

1. Process the remote controller cable.

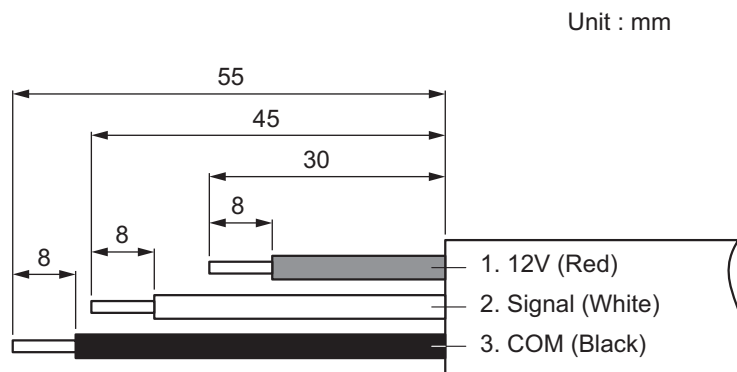

2. Insert the flat-blade screwdriver and twist it slightly to separate the front case and rear case.

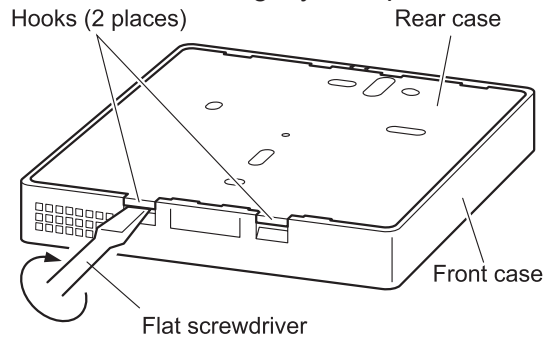

3. Attach the remote controller.

• **When attaching to switch box:**

- Seal the wiring hole of the remote controller cable.
- Put a remote controller cable through the hole of the rear case.
- Fix the rear case by securing it with attached screws (2 places).

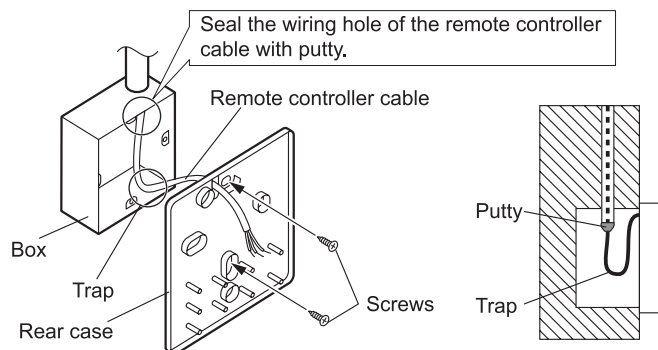
• **When attaching to the wall directly:**

- Seal the wiring hole of the remote controller cable.
- Put a remote controller cable through the back hole of the rear case of the main body.
- Fix the rear case by securing it with attached screws (2 places).

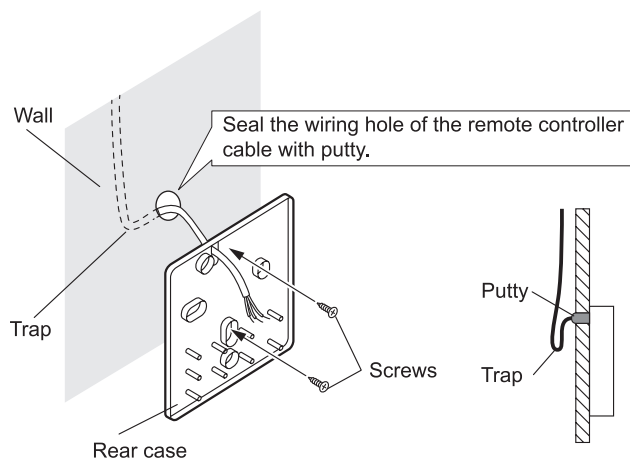
• **When routing the cable on-wall:**

- Cut off the cable guide of the front case with using a knife or a nipper.
- Deburr the edge of the cable guide.

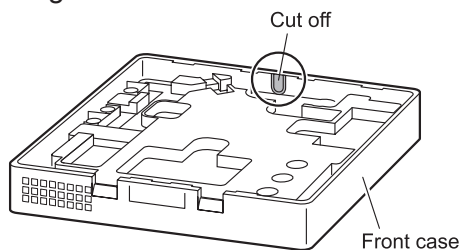

- Fix the rear case by securing it with attached screws (2 places).

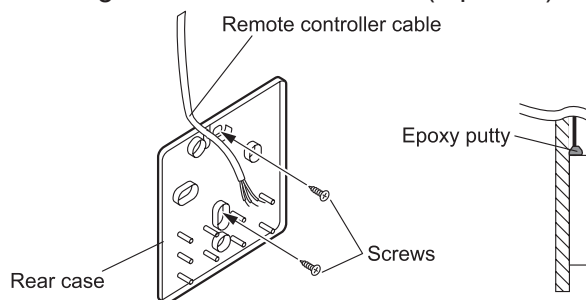

4. Connect the cable to the terminals on the front case.
Fix the cable together with the sheath with the cable tie. Cut off the excess cable tie.

Tightening torque	
Terminal screw	0.8 to 1.2 N•m

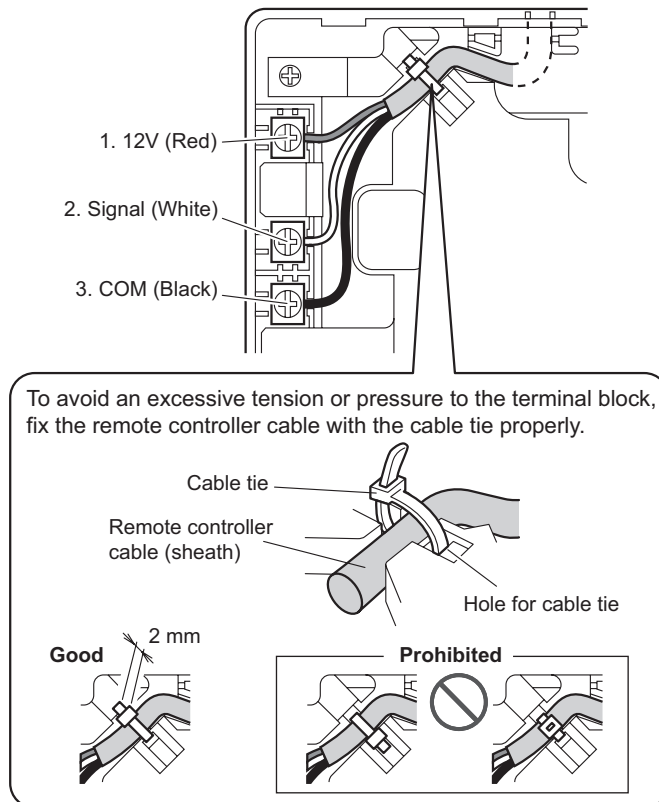

⚠ CAUTION

- Be careful to avoid breaking the cable by over-tightening the cable tie.
- When connecting the remote controller cables, do not over-tighten the screws.

5. Attach the front case.
 - Insert after adjusting upper part of front case.
 - When insert the front case, do not pinch the cable.

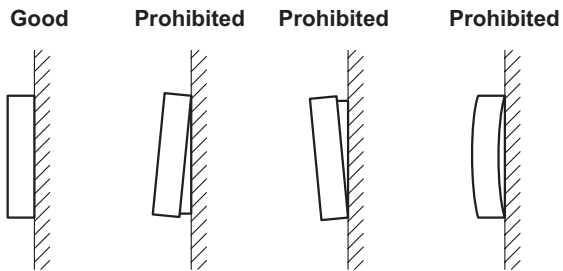
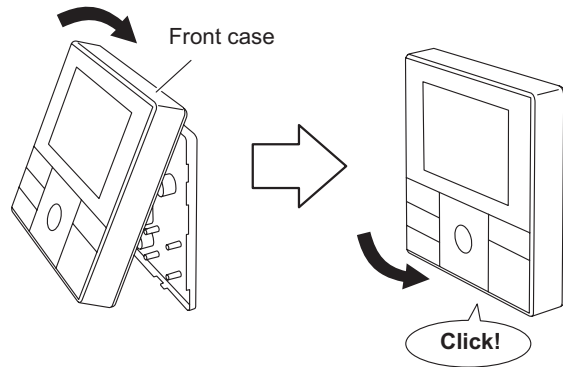

⚠ CAUTION

Insert the upper case firmly. If improperly attached, it will cause the upper case to fall off.

■ Installation

● Connection pattern

NOTE: Connection pattern is different according to type of Indoor unit.

Indoor unit type	Connection pattern
Compact cassette	Pattern A
Cassette	
Slim duct	
Duct	
Floor/Ceiling	
Ceiling	Pattern B

● Pattern A

Connect the end of remote controller cable directly to the exclusive terminal block.

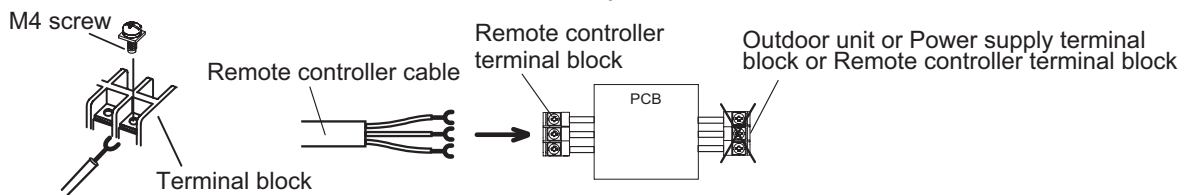

NOTE: It may be failed if it is connected to the outdoor unit or the terminal block for power supply.

● Pattern B

1. Modify the remote controller cable as follows:

- Use a tool to cut off the terminal on the end of the remote controller cable and then remove the insulation from the cut end of the cable as shown in following figure.
- Connect the remote controller cable and connecting cable as shown in following figure.
- Be sure to insulate the connection between the cables.

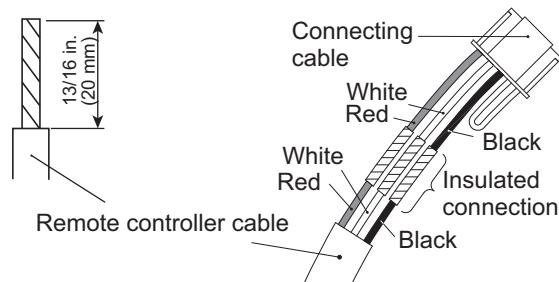

2. Connect the remote controller cable.

- Connect the cable made in step 1. to the indoor unit PCB.

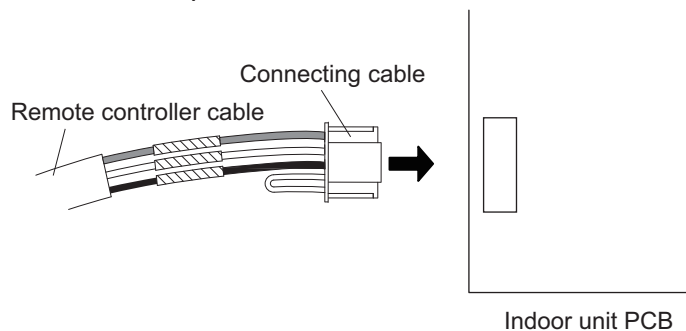

7-6. Simple remote controller (UTY-RSNGM: Optional part)

Overview

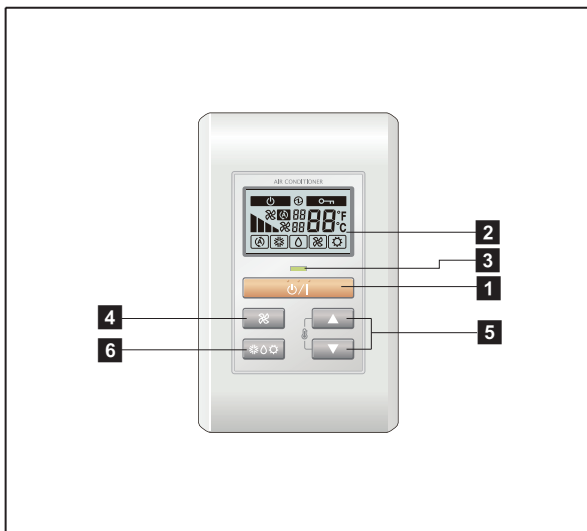

Display panel

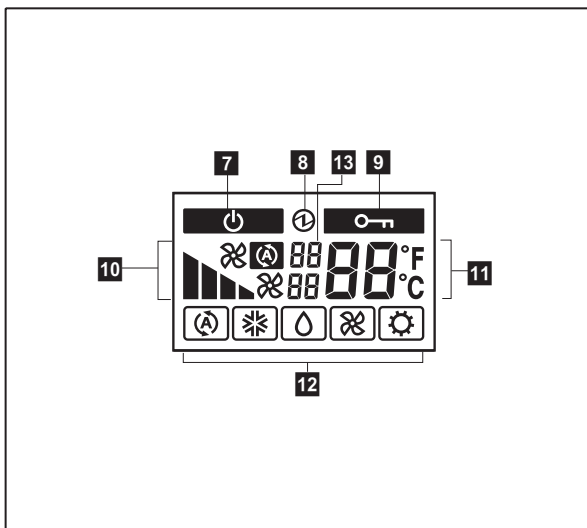

1 START/STOP button

Starts and stops operation.





2 Display backlight button

Lights during operation.

3 Operation lamp

Lights during operation.





4 FAN button

Selects the fan speed (AUTO , HIGH , MED , LOW , and QUIET ).

5 SET TEMP. button

Selects the setting temperature.

6 MODE button

Selects the operating mode (AUTO , COOL , DRY , FAN , HEAT ).

7 Standby indicator

Indicates during the oil recovery and defrosting operation.

8 Power source indicator

Indicates the main power is on.

9 Central control indicator

Indicates when function is locked.

10 Fan speed indicator

Deletes the weekly timer schedule.

11 Set temperature

- Indicates error history number in error code history display mode.
- Indicates indoor unit address in address display mode.

12 Operating mode indicator

13 Indicator

- Upper:
 - Indicates the error code in error code history display mode and in self diagnosis mode.
 - Indicates the refrigerant system address in address display mode.
- Lower: Indicates the remote controller address in error code history display mode, address display mode, and self diagnosis mode.

System diagram

1 remote controller:

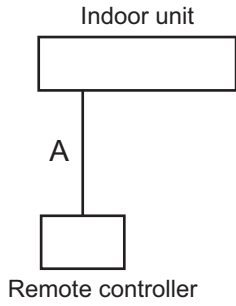

2 remote controllers:

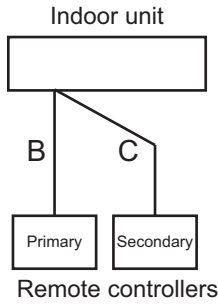

A, B, C: Remote controller cable
 $A \leq 500 \text{ m}; B + C \leq 500 \text{ m}$

Electrical wiring

1 remote controller:

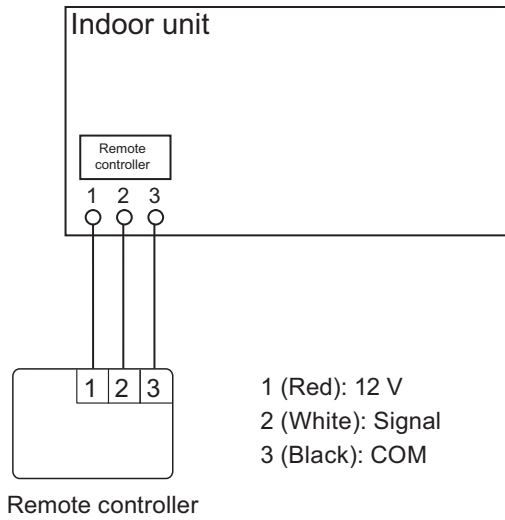

2 remote controllers:

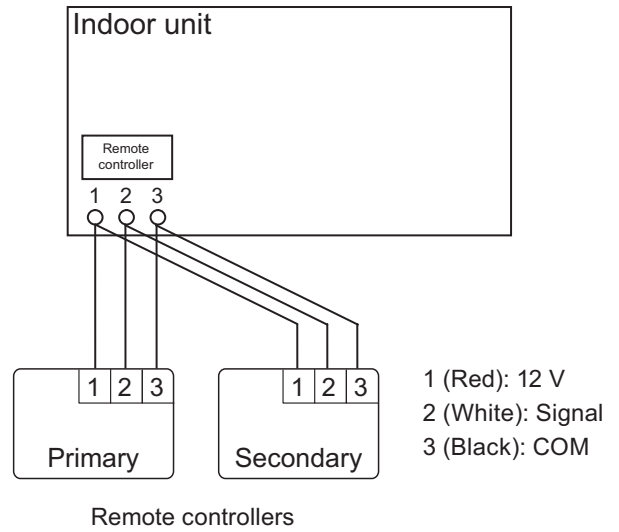

■ Specifications

Dimensions and other specifications on the wired remote controller are as follows.

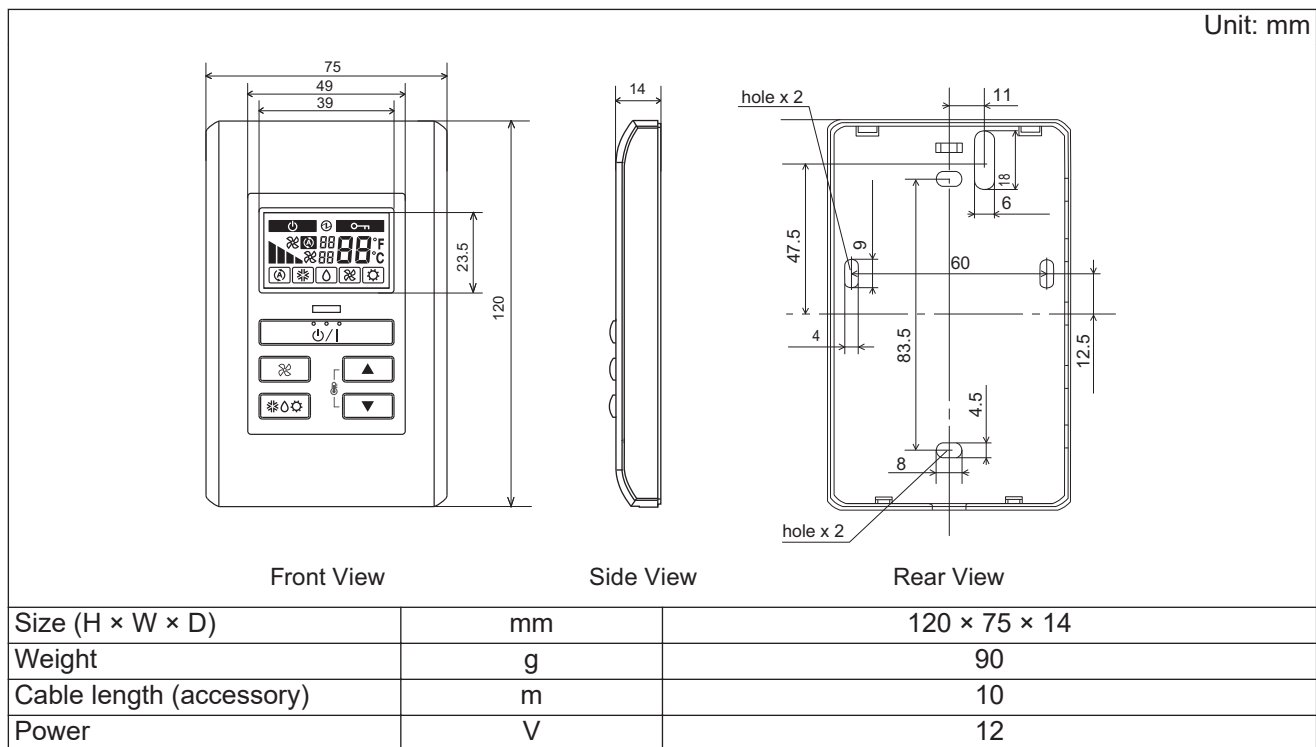

● Wiring specifications

Use	Size	Wire type	Remarks
Remote controller cable	0.33 mm ²	Polar 3 core	Use sheathed PVC cable.

■ Installation

● Connection pattern

NOTE: Connection pattern is different according to type of Indoor unit.

Indoor unit type	Connection pattern
Compact cassette	Pattern A
Cassette	
Slim duct	
Duct	
Floor/Ceiling	
Ceiling	Pattern B

● Pattern A

Connect the end of remote controller cable directly to the exclusive terminal block.

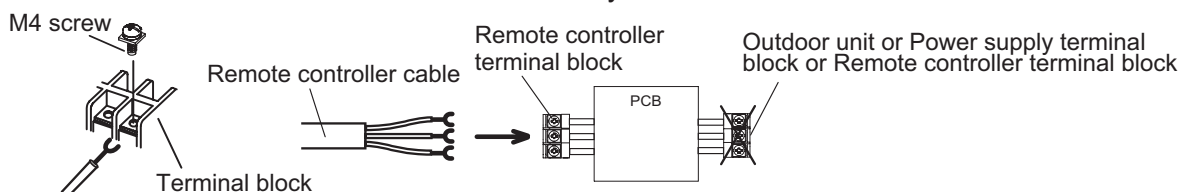

NOTE: It may be failed if it is connected to the outdoor unit or the terminal block for power supply.

● Pattern B

1. Modify the remote controller cable as follows:

- Use a tool to cut off the terminal on the end of the remote controller cable and then remove the insulation from the cut end of the cable as shown in following figure.
- Connect the remote controller cable and connecting cable as shown in following figure.
- Be sure to insulate the connection between the cables.

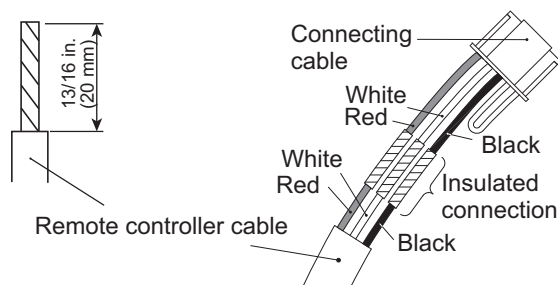

2. Connect the remote controller cable.

- Connect the cable made in step 1. to the indoor unit PCB.

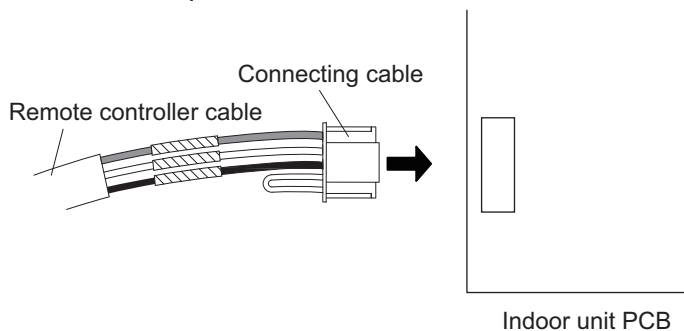

8. Function settings

To adjust the functions of this product according to the installation environment, various types of function settings are available.

NOTE: Incorrect settings can cause a product malfunction.

8-1. Indoor unit (setting by DIP switch and jumper wire)

By using some components on the PCB, you can change the function settings.

Related components on the PCB and the applicable settings:

Component		Setting content
DIP switch	1	Remote controller address setting
	2	
	3	
	4	
Jumper wire	JM1	Drainage function setting
	JM2	Auto louver grille setting
	JM3	Fan delay setting

■ Component location

Components on the indoor unit main PC board used for the function settings are located as shown in the following figure.

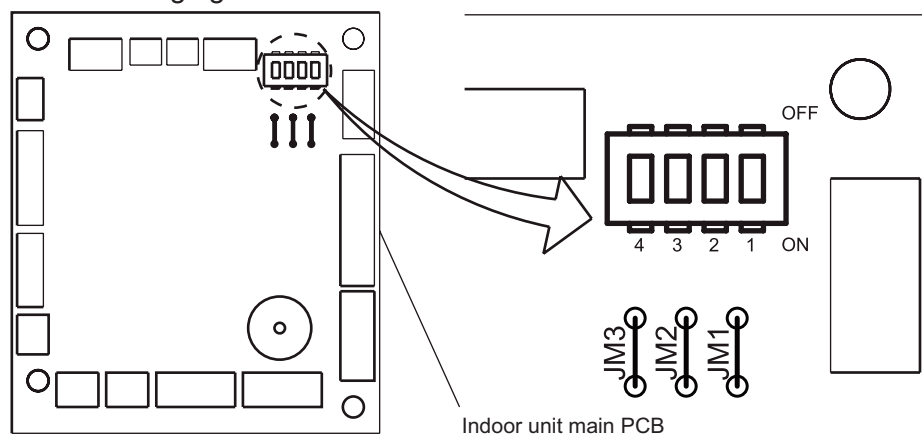

■ Dip switch setting

Remote controller address setting:

When operating a number of indoor units by using a wired remote controller, DIP switch setting for assigning unit number to each indoor unit is required.

DIP switches are normally set to make the unit number 00.

Remote controller address	DIP switch number				Factory setting
	1	2	3	4	
00	OFF	OFF	OFF	OFF	◆
01	ON	OFF	OFF	OFF	
02	OFF	ON	OFF	OFF	
03	ON	ON	OFF	OFF	
04	OFF	OFF	ON	OFF	
05	ON	OFF	ON	OFF	
06	OFF	ON	ON	OFF	
07	ON	ON	ON	OFF	
08	OFF	OFF	OFF	ON	
09	ON	OFF	OFF	ON	
10	OFF	ON	OFF	ON	
11	ON	ON	OFF	ON	
12	OFF	OFF	ON	ON	
13	ON	OFF	ON	ON	
14	OFF	ON	ON	ON	
15	ON	ON	ON	ON	

■ Jumper wire setting

• Drainage function setting (JM1)

JM1	Function	Factory setting
Connect	Enable	◆
Disconnect	Disable	

• Auto louver grille setting (JM2)

When auto louver grille kit (optional parts) is attached, set the auto louver grille setting "Enable".

JM2	Function	Factory setting
Connect	Disable	◆
Disconnect	Enable	

• Fan delay setting (JM3)

JM3	Function	Factory setting
Connect	Disable	◆
Disconnect	Enable	

8-2. Indoor unit (setting by wireless remote controller)

⚠ CAUTION

This setting changes the function settings used to control the indoor unit according to the installation conditions. Incorrect settings can cause a product malfunction.

- After the power is turned on, perform the "Function setting" according to the installation conditions using the remote controller.
- The settings may be selected between the following two: Function number or Setting number.
- Settings will not be changed if invalid numbers or setting numbers are selected.

■ Preparation

Before connecting the power supply of the indoor unit, reconfirm following items:

- Piping air tight test and vacuuming have been performed firmly.
- There is no wiring mistake. Then, connect the power supply of the indoor unit.

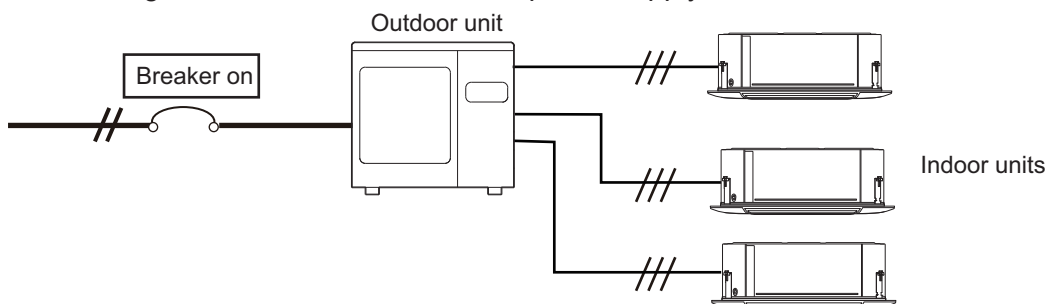

■ AR-RAH2E/AR-RAH1E

● Button name and function

During address setting mode, indoor unit reject the any operation command from remote controller.

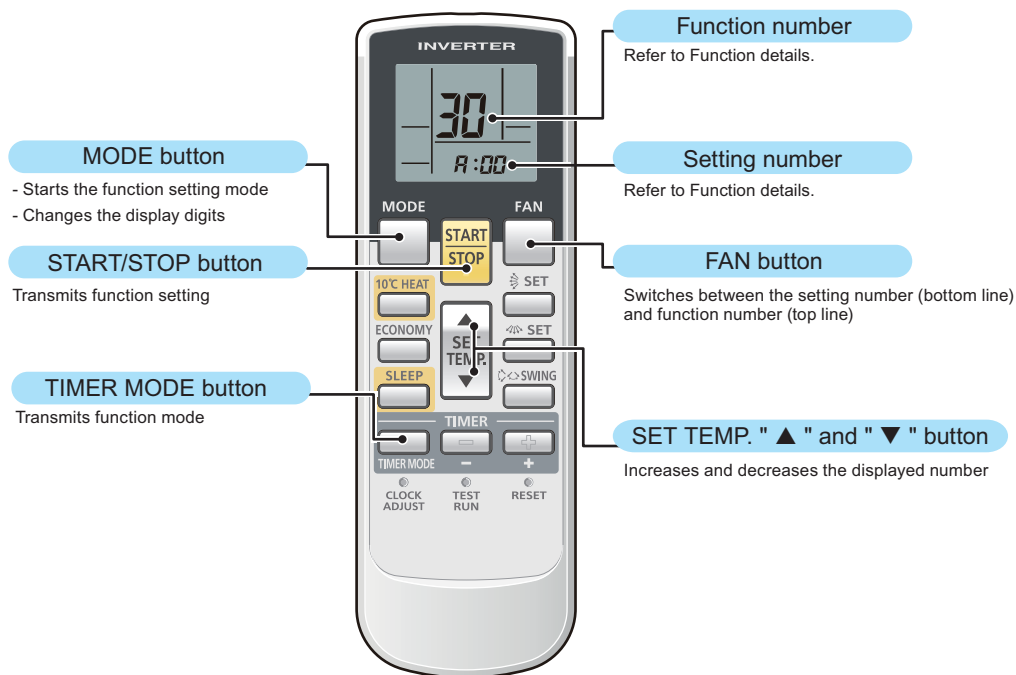

NOTE: Actual number of buttons might be different from the figures in following instructions.

● Function setting procedure

1. Connect the power supply of the outdoor unit.
2. To enter the function setting mode, while holding down the FAN and the SET TEMP. ▲ buttons, press the RESET button.

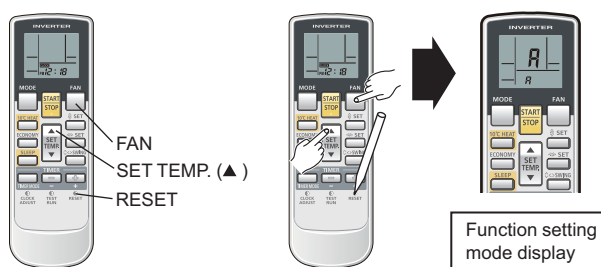

3. Press the SET TEMP. ▲ or ▼ buttons to select the custom code that matches the setting with the indoor unit. By selecting the appropriate custom code, the communication between the indoor unit and the wireless remote controller become possible.

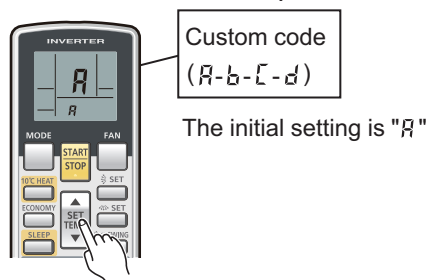

4. For confirming the custom code, press the TIMER MODE button to send the code to the indoor unit.

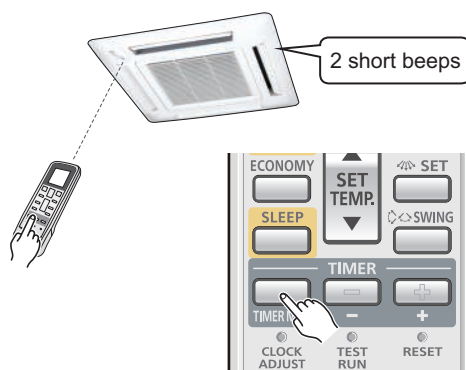

5. Press the MODE button to enter the function setting mode.

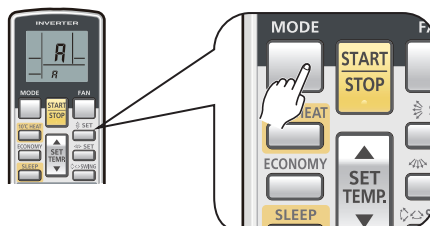

6. Select the function number by pressing the ▲ or the ▼ button. Each time the MODE button is pressed, it switches between the left digit and the right digit.

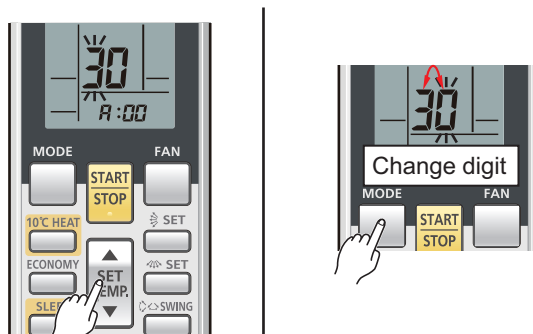

7. Proceed to number setting by pressing the FAN button.
To return to the function number selection, press the FAN button again.



8. Select the setting number by pressing the ▲ or the ▼ button.
Each time the MODE button is pressed, it switches between the left digit and the right digit.

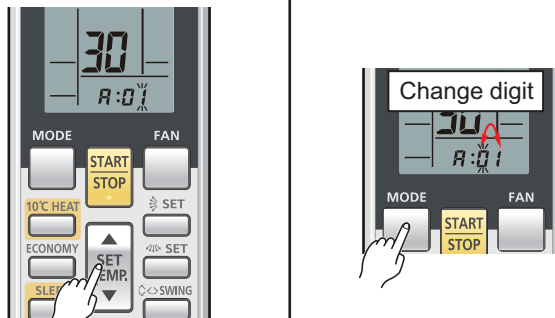

9. Send the function mode information by pressing the TIMER MODE button once.

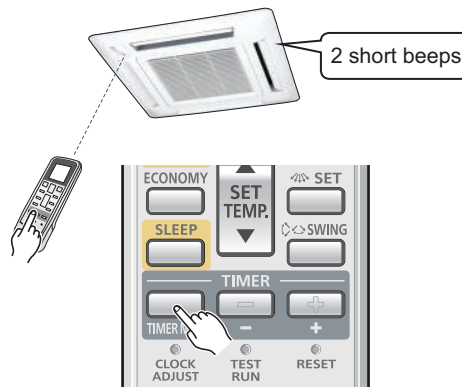

10. Send the function setting information by pressing the START/STOP button once.
2 short beeps will be emitted from the indoor unit when the signal is received correctly. If wrong code is set, no beep sound will be emitted.

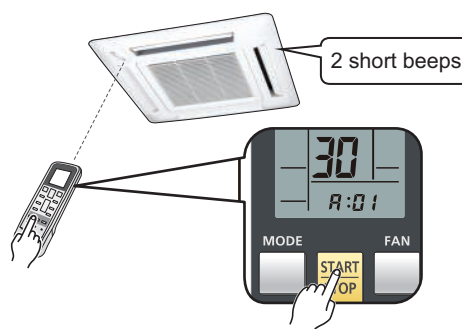

NOTE: Press START/STOP button within 30 seconds after pressing TIMER MODE button.

Function details: Refer to Chapter 8-6. ["Function details"](#) on page 284.

11. Exit the function setting mode by pressing the RESET button.

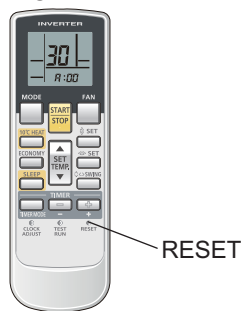

To set custom code b , c , or d , perform same procedures for each code.

● Setting up each indoor unit

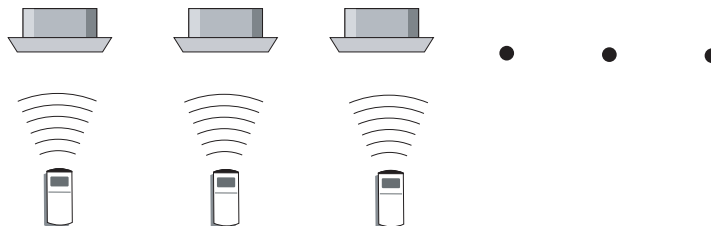

Repeat step from 1. to 11. to set up each indoor unit. If the custom code is other than "F", steps from 1. to 4. and 11. need to be performed.

● Resetting the power after setting up all indoor units

Important:

- If the reset is not performed, function cannot be read correctly.
- After all the functions have been set, the circuit breaker needs to be switched off for at least 2 minutes.
 - After the 2 minutes has passed, power can be restored.
 - The set function is stored in the PCB and will remain in memory even when the power of indoor unit is turned off. However setting function is effective after disconnecting the power supply and then reconnecting it.
- Record the latest configuration of the indoor unit function setting on a label, and put the label on the unit so it can be used for after-sales service operations.

Once the RESET button is pressed on the remote controller, the operation mode will be set to the AUTO MODE.

Adjust the operation mode to either cooling or heating before starting the operation of the air conditioner.

NOTE: If custom code other than "F" is set, the remote control must be set accordingly to the indoor unit setting.

● Remote controller custom code setting

Custom code setting of wireless remote controller needs to be same as the setting of the indoor unit. When you change the custom code setting of the wireless remote controller, do as follows:

1. Press the START/STOP button until only the clock is displayed on the remote controller display.

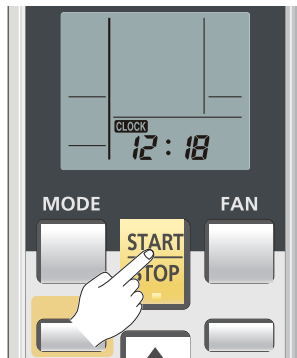

2. Press the MODE button for at least 5 seconds to display the current custom code (initially set to A).

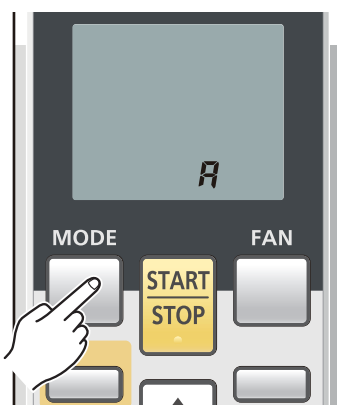

3. Press the SET TEMP. ▲ or the ▼ button to change the custom code between A → b → c → d.

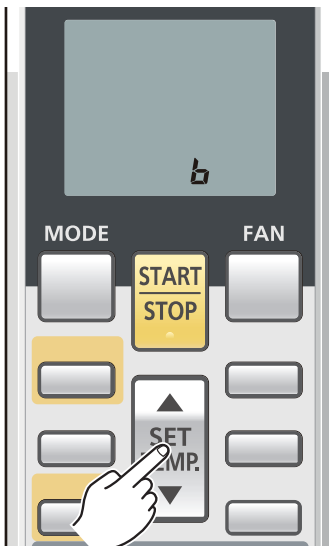

4. Press the MODE button again to return to the clock display. The custom code will be changed.

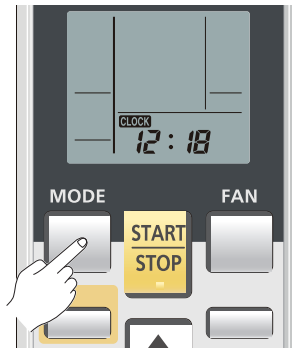

- If no buttons are pressed within 30 seconds after the custom code is displayed, the system returns to the original clock display. In this case, start again from step 1.
- The air conditioner custom code is set to A prior to shipment.
- The remote controller resets to custom code A when the batteries in the remote controller are replaced. If you use a custom code other than custom code A, reset the custom code after replacing the batteries. If you do not know the air conditioner custom code setting, try each of the custom codes (A → B → C → D) until you find the code which operates the air conditioner.

8-3. Indoor unit (setting by wired remote controller)

- The function settings of the control of the indoor unit can be changed by this procedure according to the installation conditions. Incorrect settings can cause the indoor unit malfunction.
- After the power is turned on, perform the “Function setting” according to the installation conditions using the remote controller.
- The settings may be selected between the following two: Function number or Setting number.
- Settings will not be changed if invalid numbers or setting numbers are selected.
- This function cannot be used on the secondary units.

■ Preparation

Before connecting the power supply of the indoor unit, reconfirm following items:

- Piping air tight test and vacuuming have been performed firmly.
- There is no wiring mistake. Then, connect the power supply of the indoor unit.

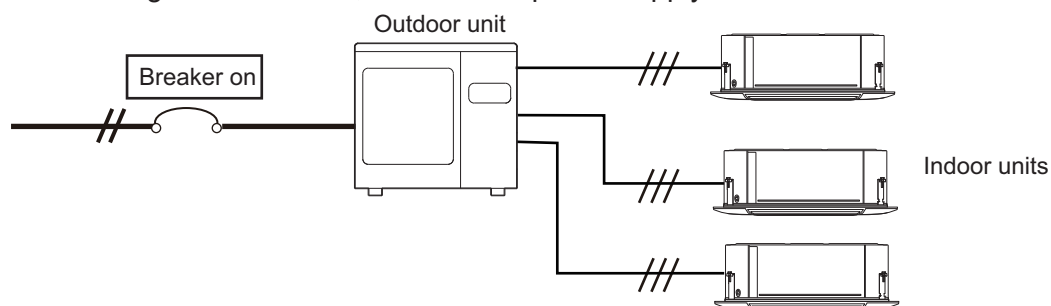

■ UTY-RNNGM

● Button name and function

During address setting mode, indoor unit reject the any operation command from remote controller.

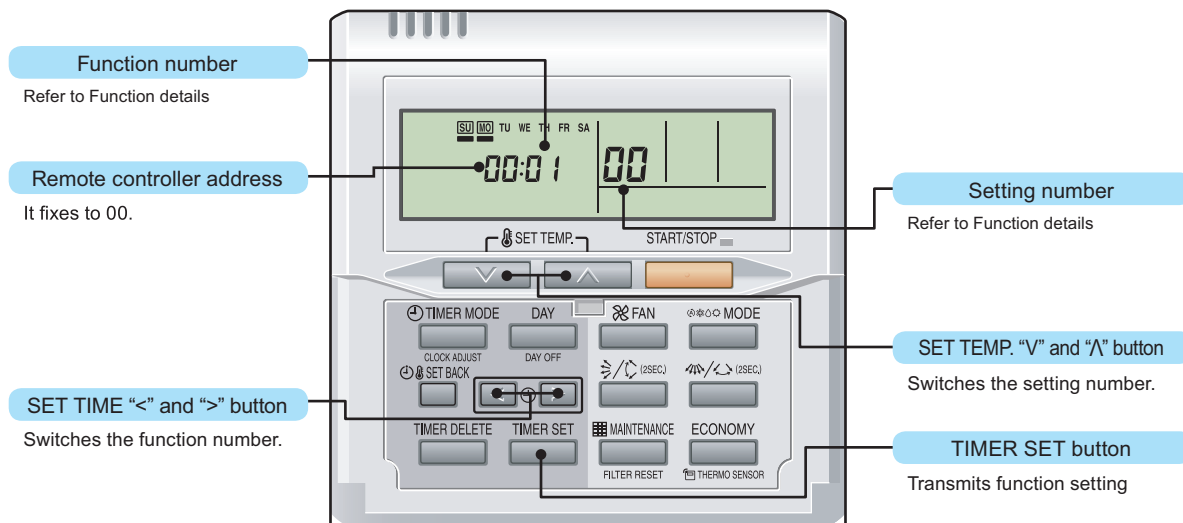

● Function setting procedure

1. Connect the power supply of the outdoor unit.
2. Switch to the function setting mode.
To enter the function setting mode, hold down the 3 buttons of SET TEMP. ∨, SET TEMP. ∧, and FAN at the same time for 5 seconds or longer.

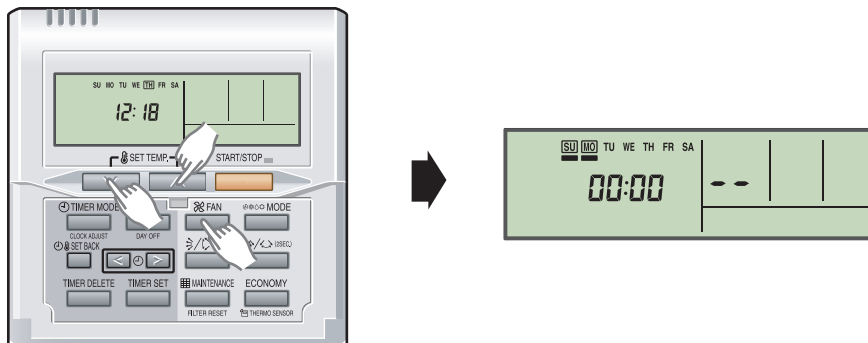

3. Select the function number by pressing the SET TIME < or the SET TIME > button.

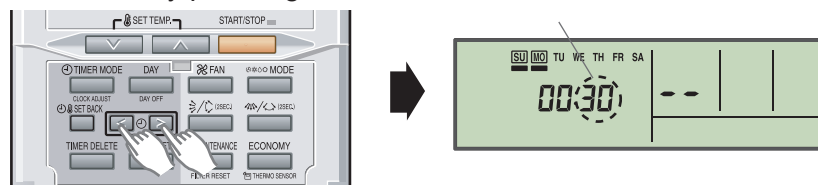

4. Select the setting number by pressing the SET TEMP. ∧ or the SET TEMP. ∨ button. The display flashes during setting number selection.

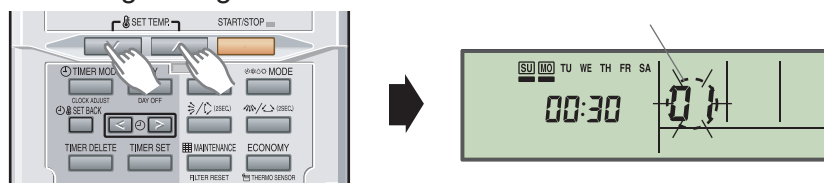

5. Confirm the setting by pressing the TIMER SET button.
The data will be transferred to the indoor unit.

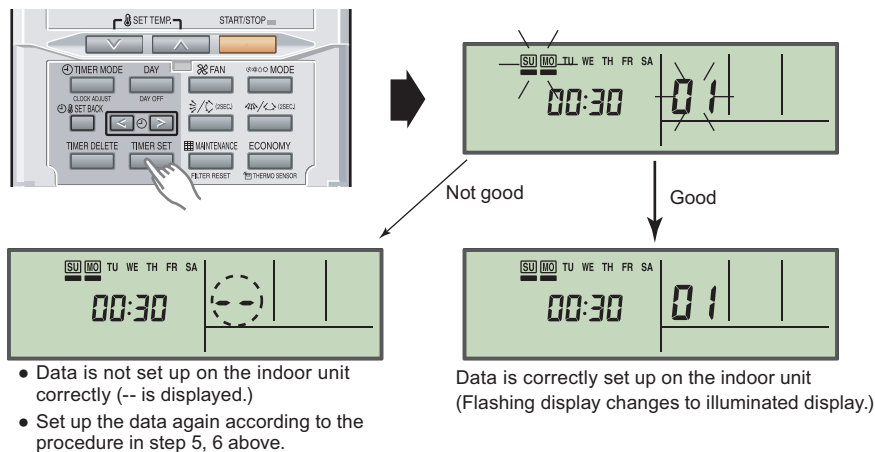

Function details: Refer to Chapter 8-6. "[Function details](#)" on page 284.

6. Exit the function setting mode by holding 3 buttons of SET TEMP. ∇ , SET TEMP. \wedge and FAN at the same time.

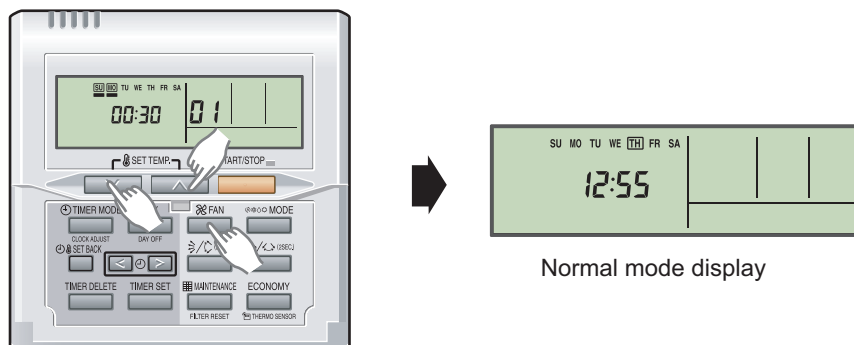

If no button is pressed within 60 seconds after buttons mentioned above are pressed, it will automatically exit the function setting mode.

If you exit the function setting mode unintentionally during setting, enter the mode again according to the procedure in step 2.

● Setting up each indoor unit

Repeat the procedures from step 1 to 6, and set up the indoor units requiring function setting.

● Resetting the power after setting up function of all indoor units

NOTES:

- If the reset is not performed, function cannot be read correctly.
- After all the functions have been set, the circuit breaker needs to be switched off for at least 2 minutes.
 - After the 2 minutes has passed, power can be restored.
 - The set function is stored in the PCB and will remain in memory even when the power of indoor unit is turned off.
However setting function is effective after disconnecting the power supply and then reconnecting it.
- Record the latest configuration of the indoor unit function setting on a label, and put the label on the unit so it can be used for after-sales service operations.

■ UTY-RVNGM

● Function setting procedure

1. Connect the power supply of the outdoor unit.
2. Switch to the function setting mode.
When [Menu button] is pressed twice while “Monitor” screen is displayed, it switches to the “Submenu” screen. If [Menu button] is pressed while the “Submenu” screen is displayed, the display returns to the “Monitor” screen.

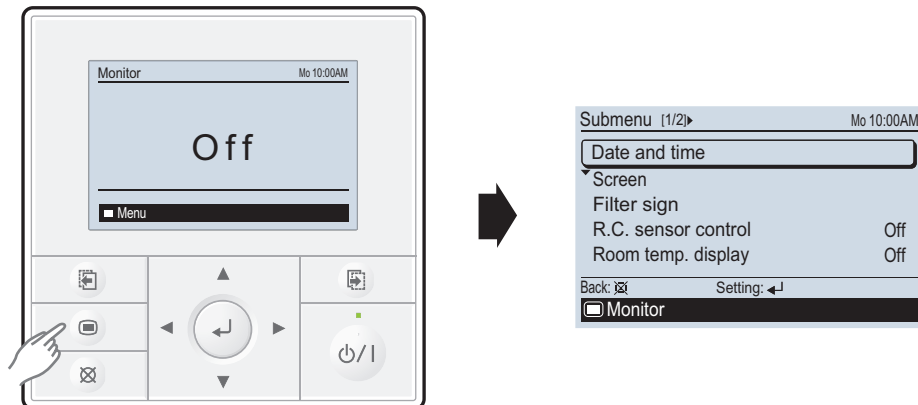

Press the [Screen switch button (Left)] and [Screen switch button (Right)] simultaneously for 5 seconds to switch to “Service” screen.

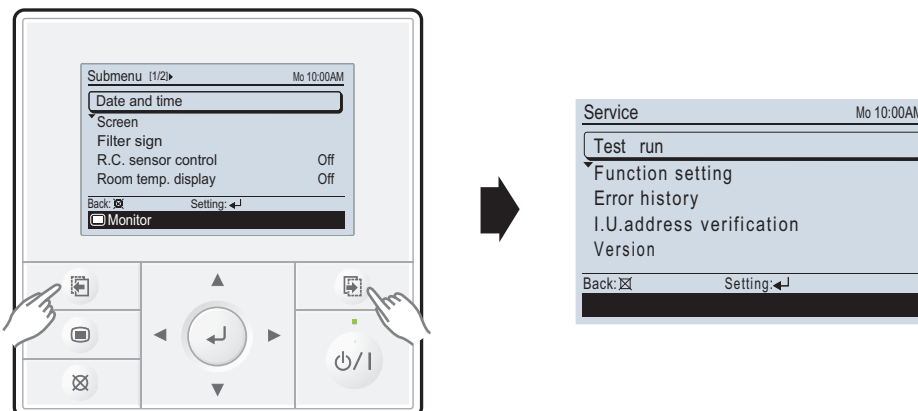

Select [Function setting] with pressing the [Cursor button (Up/Down)], and press the [Enter button].

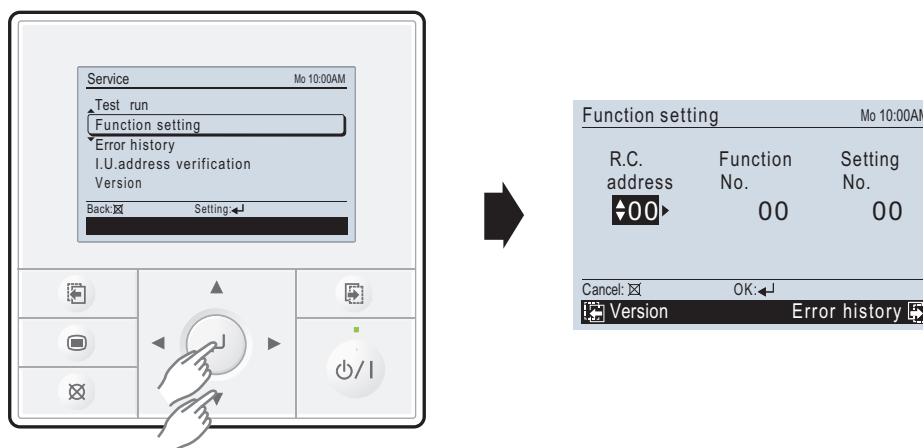

3. Select the [Function No.] with pressing the [Cursor button (Left/Right)], and select the Function No. to be set with pressing the [Cursor button (Up/Down)].

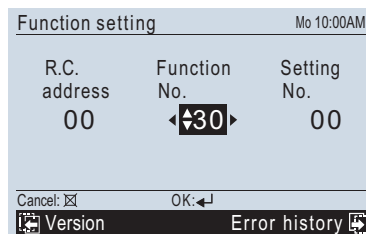
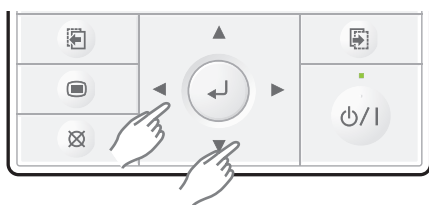

4. Select the [Setting No.] with pressing the [Cursor button (Left/Right)], and select the Setting No. to be set with pressing the [Cursor button (Up/Down)].

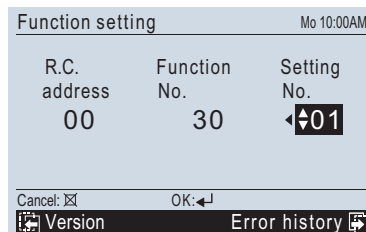
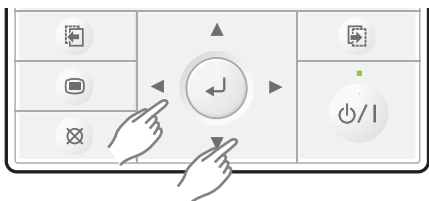

5. Pressing the [Enter button], confirm the setting. The data will be transferred to the indoor unit.

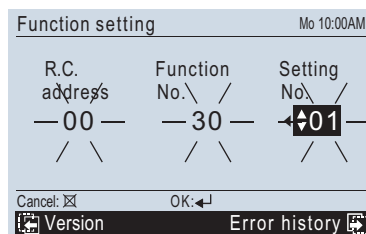
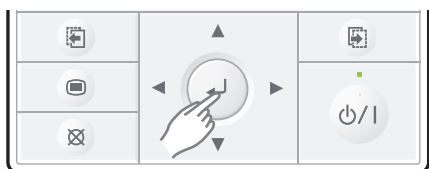

Error

Good

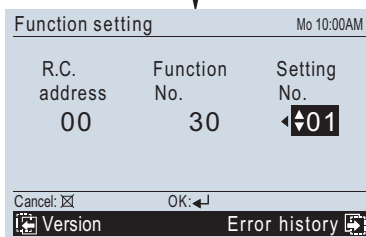
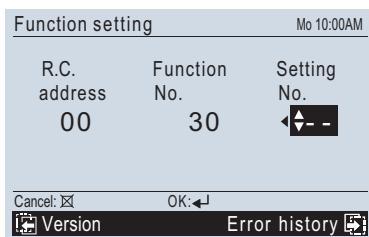

Function details: Refer to Chapter 8-6. ["Function details"](#) on page 284.

6. When [Cancel button] is pressed twice while “Function setting” screen is displayed, it switches to the “Submenu” screen.

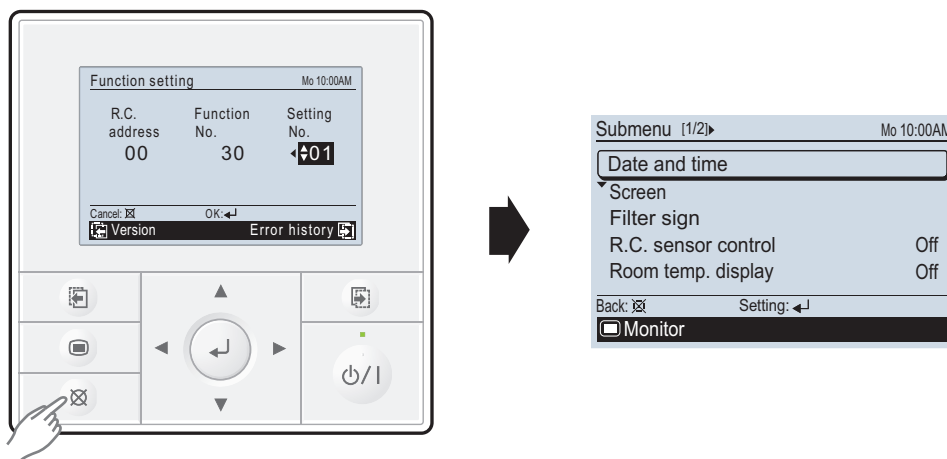

If no button is pressed within 60 seconds after buttons mentioned above are pressed, it will automatically exit the function setting mode.

If you exit the function setting mode unintentionally during setting, enter the mode again according to the procedure in step 2.

● Setting up each indoor unit

Repeat the procedures from step 1 to 6, and set up the indoor units requiring function setting.

● Resetting the power after setting up function of all indoor units

NOTES:

- If the reset is not performed, function cannot be read correctly.
- After all the functions have been set, the circuit breaker needs to be switched off for at least 2 minutes.
 - After the 2 minutes has passed, power can be restored.
 - The set function is stored in the PCB and will remain in memory even when the power of indoor unit is turned off.
However setting function is effective after disconnecting the power supply and then reconnecting it.
- Record the latest configuration of the indoor unit function setting on a label, and put the label on the unit so it can be used for after-sales service operations.

8-4. Indoor unit (setting by simple remote controller)

- The function settings of the control of the indoor unit can be changed by this procedure according to the installation conditions. Incorrect settings can cause the indoor unit malfunction.
- After the power is turned on, perform the “Function setting” according to the installation conditions using the remote controller.
- The settings may be selected between the following two: Function number or Setting number.
- Settings will not be changed if invalid numbers or setting numbers are selected.
- This function cannot be used on the secondary units.

■ Preparation

Before connecting the power supply of the indoor unit, reconfirm following items:

- Piping air tight test and vacuuming have been performed firmly.
- There is no wiring mistake. Then, connect the power supply of the indoor unit.

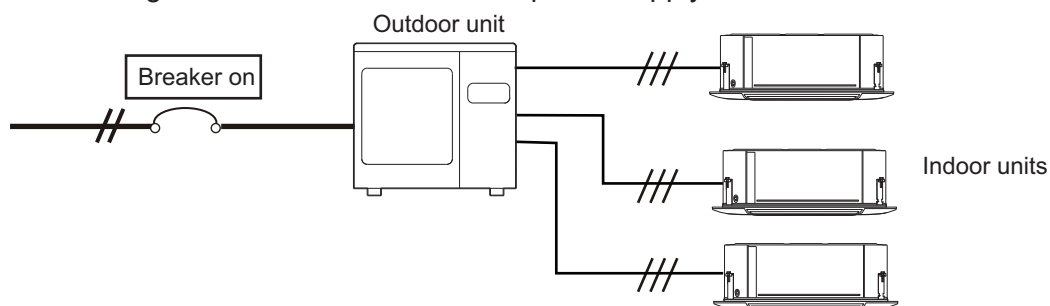

■ UTY-RSNGM

● Button name and function

During address setting mode, indoor unit reject the any operation command from remote controller.

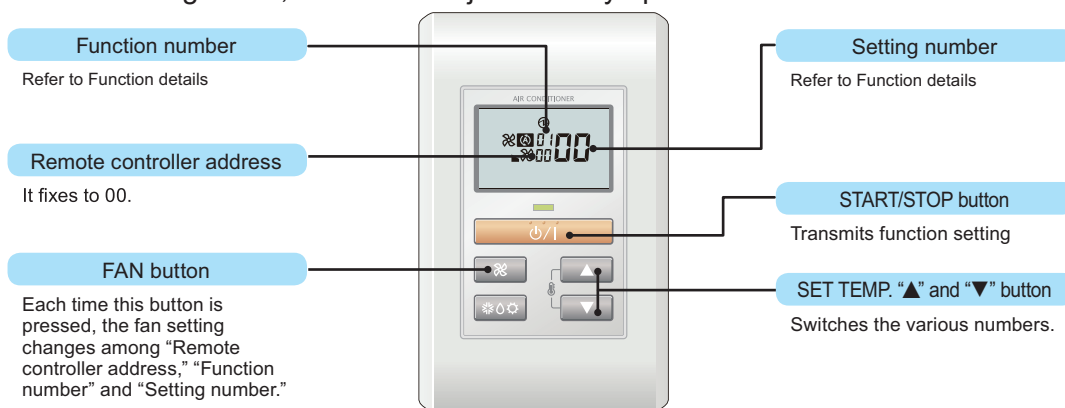

● Function setting procedure

1. Connect the power supply of the outdoor unit.
2. Switch to the function setting mode.

To enter the function setting mode, hold down the 3 buttons of SET TEMP. ▲, SET TEMP. ▼ and FAN at the same time for 5 seconds or longer.

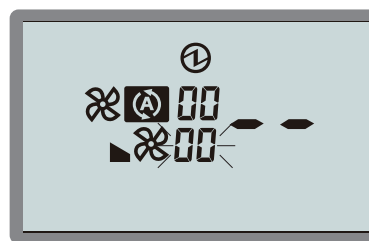
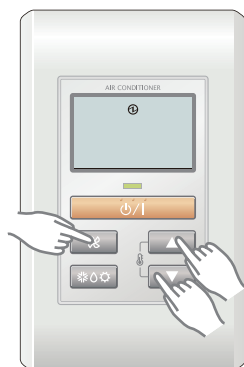

Function setting mode initial display

3. Press the FAN button.

The Function number indicator flashes. Then, press either the SET TEMP. ▲ button or the SET TEMP. ▼ button to set up the function number.

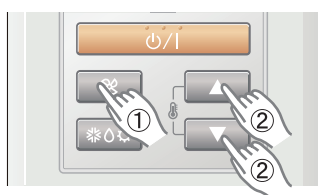

Function number

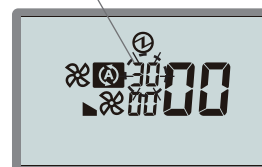

4. Select the setting number by pressing the SET TEMP. ▲ or SET TEMP. ▼ button. The setting number indicator flashes during setting number selection.

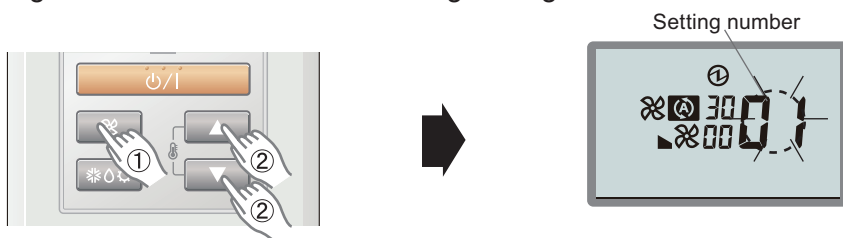

Example) Function number : 30, Setting number : 01

5. Confirm the setting by pressing the TIMER SET button. The data will be transferred to the indoor unit.

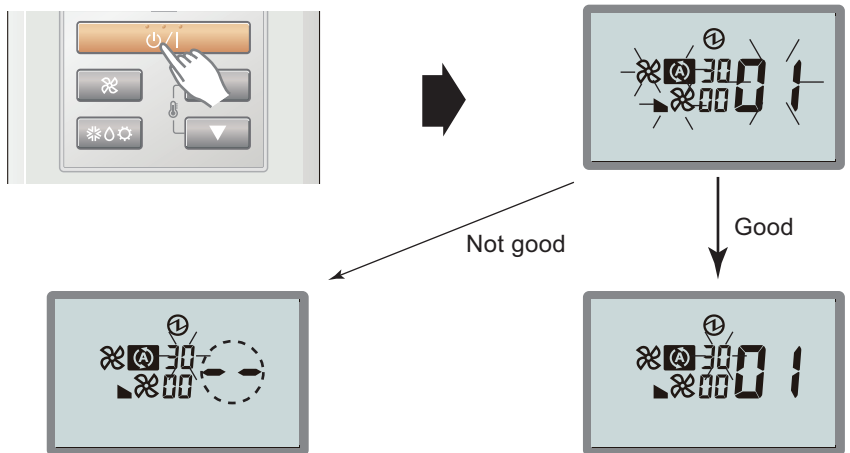

- Data is not set up on the indoor unit correctly (-- is displayed.)
- Set up the data again according to the procedure in step 3, 4 above.

Data is correctly set up on the indoor unit.

Function details: Refer to Chapter 8-6. "[Function details](#)" on page 284.

6. Exit the function setting mode by pressing the 3 buttons of SET TEMP. ▲, SET TEMP. ▼, and FAN at the same time for 5 seconds or longer. After exiting the function setting mode, the display returns to the normal mode.

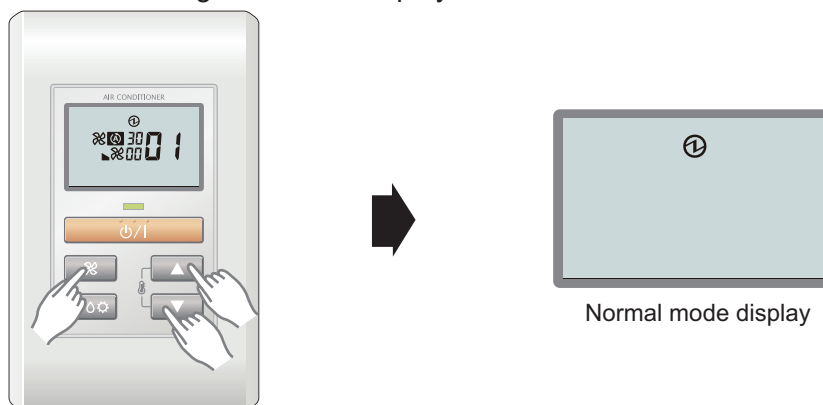

If no button is pressed within 60 seconds after buttons mentioned above are pressed, it will automatically exit the function setting mode.

If you exit the function setting mode unintentionally during setting, enter the mode again according to the procedure in step 2.

● Setting up each indoor unit

Repeat the procedures from step 1 to 6, and set up the indoor units requiring function setting.

● Resetting the power after setting up function of all indoor units

NOTES:

- If the reset is not performed, function cannot be read correctly.
- After all the functions have been set, the circuit breaker needs to be switched off for at least 2 minutes.
 - After the 2 minutes has passed, power can be restored.
 - The set function is stored in the PCB and will remain in memory even when the power of indoor unit is turned off.
However setting function is effective after disconnecting the power supply and then reconnecting it.
- Record the latest configuration of the indoor unit function setting on a label, and put the label on the unit so it can be used for after-sales service operations.

8-5. Outdoor unit

■ Local setting switch buttons

● Control PCB and switch buttons location

Control PCB of the outdoor unit is located as shown in the following figure.

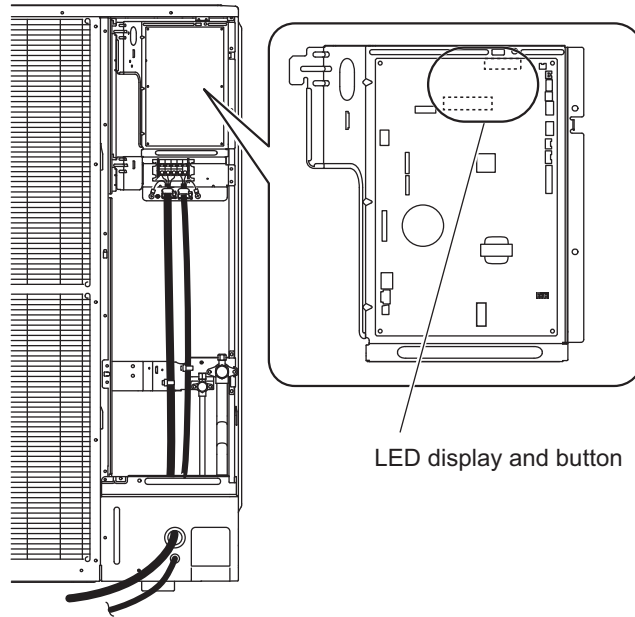

● Switch buttons and the functions

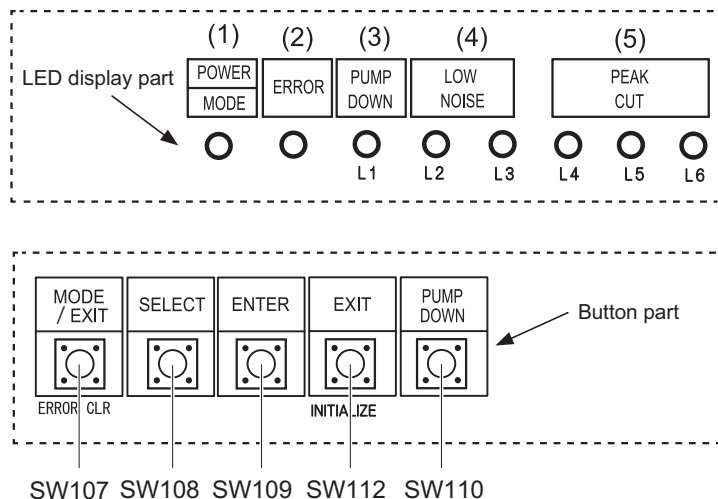

LED lamp			Function or operation method
(1)	POWER/MODE	Green	Lights on while power on. Local setting in outdoor unit or error code is displayed with blink.
(2)	ERROR	Red	Blinks during error operation.
(3)	PUMP DOWN (L1)	Orange	Lights on during pump down operation.
(4)	LOW NOISE MODE (L2 and L3)	Orange	Lights on during “Low noise mode” when local setting is activated. (Lighting pattern of L2 and L3 indicates low noise level.)
(5)	PEAK CUT MODE (L4, L5, and L6)	Orange	Lights on during “Peak cut mode” when local setting is activated. (Lighting pattern of L4, L5, and L6 indicates peak cut level.)

Switch button		Function or operation method
SW107	MODE	Switches between “Local setting” and “Error code display”.
SW108	SELECT	Switches between the individual “Local settings” and the “Error code displays”.
SW109	ENTER	Switches between the individual “Local settings” and the “Error code displays”.
SW112	EXIT	Returns to “Operation status display”.
SW110	PUMP DOWN	Starts the pump down operation.

● Function setting table

No.	Setting item		LED display							Factory setting	
			POWER MODE	ERROR	PUMP DOWN	LOW NOISE		PEAK CUT			
					(L1)	(L2)	(L3)	(L4)	(L5)		(L6)
1	Low noise mode setting	Level 1	Blink (9 times)	○	○	○	●	○	○	●	◆
		Level 2		○	○	○	●	○	●	○	
2	Peak cut mode setting	Level 1		○	○	●	○	○	○	●	
		Level 2		○	○	●	○	○	●	○	
		Level 3		○	○	●	○	○	●	●	
		Level 4		○	○	●	○	●	○	○	◆

Sign "○": Lights off, "●": Lights on

No.	Setting item	Content
1	Low noise mode setting	<p>By using the "Low noise mode", the limit of the noise level will be set to decrease the noise level. The mode comes in 2 levels which can be set accordingly.</p> <p>To turn on the mode, use the external input terminal (CN131).</p> <ul style="list-style-type: none"> By using this mode, the cooling/heating performance may decrease. Depending on the operating condition, the noise level may not decrease even if the Low noise mode is on.
2	Peak cut mode setting	<p>The capacity limit can be selected when operating with the "Peak Cut mode."</p> <p>The operation selection can be done by external input terminal (CN132).</p> <p>The lower the level, the more the effect of energy saving, but the cooling/heating performance decreases.</p>

Noise level as low noise mode setting

Unit: dB (A)

	AOHG72LRLA		AOHG90LRLA	
	Cooling	Heating	Cooling	Heating
Level1	53	53	53	55
Level2	51	51	51	53

Local setting procedure

NOTE: Before performing the function setting, be sure to stop the operation of the air conditioner.

Low noise mode

- Press the MODE switch button (SW107) for 3 seconds or more to switch to “Local setting mode”.
- After confirming the LED lamp of POWER/MODE blinks 9 times, press the ENTER switch button (SW109).

POWER MODE	ERROR	PUMP DOWN (L1)	LOW NOISE		PEAK CUT		
			(L2)	(L3)	(L4)	(L5)	(L6)
Blinks (9 times)	○	○	○	○	○	○	○

Sign “○”: Lights off

- Press the SELECT switch button (SW108), and adjust the LED lamp as shown below. Then the LED lamp indicates the current setting.

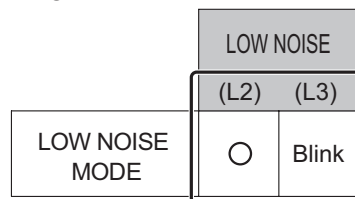

- Press the ENTER switch button (SW109).

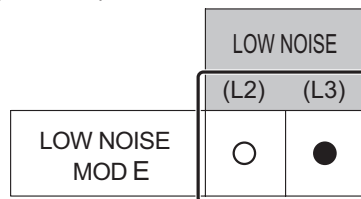

Sign “●”: Lights on

- Press the SELECT switch button (SW108), and adjust the LED lamps as shown below.

		PEAK CUT		
		(L4)	(L5)	(L6)
Level 1	Low	○	○	Blink
Level 2	Lower	○	Blink	○

- Press the ENTER switch button (SW109) and fix it.

		PEAK CUT		
		(L4)	(L5)	(L6)
Level 1	Low	○	○	●
Level 2	Lower	○	●	○

- To return to “Operating status display (Normal operation)”, press the EXIT switch button (SW112).

In case of missing how many times you pressed the SELECT and ENTER switch buttons:

- To return to “Operation status display (Normal operation)”, press the EXIT switch button once.
- Restart from the beginning of setting procedure.

● Peak cut mode

1. Press the MODE switch button (SW107) for 3 seconds or more to switch to “Local setting mode”.
2. After confirming the LED lamp of POWER/MODE blinks 9 times, press the ENTER switch button (SW109).

POWER MODE	ERROR	PUMP DOWN (L1)	LOW NOISE (L2) (L3)		PEAK CUT (L4) (L5) (L6)		
Blinks (9 times)	○	○	○	○	○	○	○

Sign “○”: Lights off

3. Press the SELECT switch button (SW108), and adjust the LED lamp as shown below. Then the LED lamp indicates the current setting.

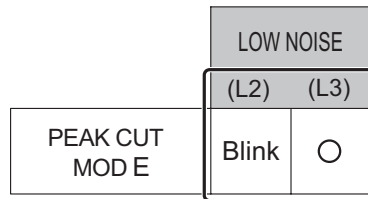

4. Press the ENTER switch button (SW109).

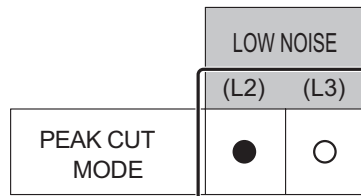

Sign “●”: Lights on

5. Press the SELECT switch button (SW108), and adjust the LED lamps as shown below.

		PEAK CUT		
		(L4)	(L5)	(L6)
Level 1	0% of rated input ratio	○	○	Blink
Level 2	50% of rated input ratio	○	Blink	○
Level 3	75% of rated input ratio	○	Blink	Blink
Level 4	100% of rated input ratio	Blink	○	○

Sign “○”: Lights off

6. Press the ENTER switch button (SW109) and fix it.

		PEAK CUT		
		(L4)	(L5)	(L6)
Level 1	0% of rated input ratio	○	○	●
Level 2	50% of rated input ratio	○	●	○
Level 3	75% of rated input ratio	○	●	●
Level 4	100% of rated input ratio	●	○	○

Sign “○”: Lights off, “●”: Lights on

7. To return to “Operating status display (Normal operation)”, press the EXIT switch button (SW112).

NOTE: When pressed number is lost during setting, you must redo the setting procedure. Return to “Operation status display (Normal operation)” by pressing the EXIT switch button once, and restart from the beginning of the setting procedure.

8-6. Function details

■ Contents of function setting

Each function setting listed in this section is adjustable in accordance with the installation environment.

NOTE: Setting will not be changed if invalid numbers or setting values are selected.

● Function setting list

	Function no.	Functions	Compact cassette	Cassette	Slim duct	Duct	Floor/Ceiling	Ceiling
1)	00	Remote controller address setting	—	—	—	●	—	—
2)	02	Refrigerant circuit address	●	●	●	●	●	●
3)	11	Filter sign	●	●	●	●	●	●
4)	20	Ceiling height	●	●	—	—	●	●
5)	21	Static pressure	—	—	—	●	—	—
6)	26	Static pressure	—	—	●	—	—	—
7)	22	Outlet directions	●	●	—	—	—	—
8)	23	Vertical airflow direction range control	—	●	—	—	—	—
9)	30	Room temperature sensor control for cooling	●	●	●	●	●	●
10)	31	Room temperature sensor control for heating	●	●	●	●	●	●
11)	40	Auto restart	●	●	●	●	●	●
12)	42	Room temperature sensor switching	●	●	●	●	●	●
13)	43	Cold air prevention	—	—	—	●	—	—
14)	44	Remote controller custom code	●	●	●	●	●	●
15)	46	External input control	●	●	●	●	●	●
16)	48	Room temperature sensor switching (Aux.)	—	—	—	●	—	—
17)	49	Indoor unit fan control for energy saving for cooling	●	●	●	●	●	●
18)	51	Primary and secondary settings	●	●	●	●	●	●

1) Remote controller address setting

NOTES:

- Because this setting is normally done automatically when 2-wire-type wired remote controller is installed, setting is unnecessary.

Multiple indoor units can be operated by using one wired remote controller.

Set the unit number of each indoor unit.

Function number	Setting value	Setting description	Factory setting
00	00	Unit no. 0	◆
	01	Unit no. 1	
	02	Unit no. 2	
	03	Unit no. 3	
	04	Unit no. 4	
	05	Unit no. 5	
	06	Unit no. 6	
	07	Unit no. 7	
	08	Unit no. 8	
	09	Unit no. 9	
	10	Unit no. 10	
	11	Unit no. 11	
	12	Unit no. 12	
	13	Unit no. 13	
	14	Unit no. 14	
	15	Unit no. 15	

NOTES:

- When connecting Polar 3-wired remote controller, set the remote controller address in the order of 0, 1, 2,, and 15.
- When different type of indoor units (such as wall mounted type and cassette type, cassette type and duct type, or other combinations) are connected using group control system, some functions may no longer be available.

2) Refrigerant circuit address

Assign the same number to all of the indoor units connected to an outdoor unit.

Function number	Setting value	Refrigerant circuit address
02	00 to 15	00
		01
		~
		14
		15

3) Filter sign

Select appropriate intervals for displaying the filter sign on the indoor unit according to the estimated amount of dust in the air of the room.

If the indication is not required, select "No indication" (03).

Function number	Setting value	Setting description	Factory setting
11	00	Standard	
	01	Long interval	
	02	Short interval	
	03	No indication	◆

Intervals will differ depending on the indoor unit type as follows.

Setting description	Compact cassette	Cassette	Slim duct	Duct	Floor	Floor/Ceiling
Standard	2,500 hours				400 hours	
Long interval	4,400 hours				1,000 hours	
Short interval	1,250 hours				200 hours	

4) Ceiling height

Select the appropriate ceiling height according to the place of installation.

Function number	Setting value	Setting description	Factory setting
20	00	Standard (2.5 m to 3.0 m)	◆
	01	High ceiling (3.0 m or more)	
	02	Low ceiling (2.7 m)	

For the specific height for each setting value, refer to "Installation space" in Chapter 3. ["Dimensions"](#) on page 10.

In case of cassette type models:

The ceiling height values are for the 4-way outlet. Do not change this setting in the 3-way outlet mode.

5) Static pressure

Select the appropriate static pressure according to the installation conditions.

Function number	Setting value	Setting description	Factory setting
21	00	Normal	◆
	01	High static pressure 1	
	02	High static pressure 2	
	03	High static pressure 3	

6) Outlet directions

Select the appropriate number of outlet directions according to the installation conditions.

Function number	Setting value	Setting description	Factory setting
22	00	4-way	◆
	01	3-way	

7) Vertical airflow direction range control

In a concealed installation, change the setting to "Fixed" (02) to restrict the movement of the upper air outlet so that the airflow is only towards the horizontal direction.

To prevent draft, change the setting to "Upward" (01).

Note that the airflow in certain usage conditions may leave the ceiling dirty. In such cases, the use of the optional Panel spacer is recommended.

Function number	Setting value	Setting description	Factory setting
23	00	Standard	◆
	01	(Setting prohibited)Upward	
	02	Fixed (Concealed)	

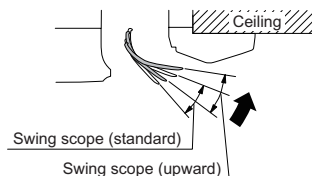

8) Static pressure

Select the appropriate static pressure according to the installation conditions.

Function number	Setting value	Setting description	Factory setting
26	00	0 Pa	
	01	10 Pa	
	02	20 Pa	
	03	30 Pa	
	04	40 Pa	
	05	50 Pa	
	06	60 Pa	
	07	70 Pa	
	08	80 Pa	
	09	90 Pa	
	31	Standard (25 Pa)	◆

9) Room temperature sensor control for cooling

Depending on the installed environment, correction of the room temperature sensor may be required. Select the appropriate control setting according to the installed environment.

Function number	Setting value	Setting description	Factory setting
30	00	Standard	◆
	01	Slightly lower control	
	02	Lower control	
	03	Higher control	

In following case, select "01":

- Wall-concealed installation in Slim duct type
- Floor installation in Floor/Ceiling type

10) Room temperature sensor control for heating

Depending on the installed environment, correction of the room temperature sensor may be required. Select the appropriate control setting according to the installed environment.

Function number	Setting value	Setting description	Factory setting
31	00	Standard	◆
	01	Lower control	
	02	Slightly higher control	
	03	Higher control	

In following case, select "01":

- Wall-concealed installation in Slim duct type
- Floor installation in Floor/Ceiling type

11) Auto restart

Enables or disables automatic restart after a power interruption.

Function number	Setting value	Setting description	Factory setting
40	00	Enable	◆
	01	Disable	

NOTE: Auto restart is an emergency function such as for power outage etc. Do not attempt to use this function in normal operation. Be sure to operate the unit by remote controller or external device.

12) Room temperature sensor switching

(Only for wired remote controller)

When using the wired remote controller temperature sensor, change the setting to "Both" (01).

Function number	Setting value	Setting description	Factory setting
42	00	Indoor unit	◆
	01	Both	

00: Sensor on the indoor unit is active.

01: Sensors on both indoor unit and wired remote controller are active.

NOTE: Remote controller sensor must be turned on by using the remote controller.

13) Cold air prevention

This setting is to disable the cold air prevention function during heating operation. When disabled, the fan setting will always follow the setting on the remote controller. (Excluding defrost mode)

Function number	Setting value	Setting description	Factory setting
43	00	Enable	◆
	01	Disable	

14) Remote controller custom code

(Only for wireless remote controller)

The indoor unit custom code can be changed. Select the appropriate custom code.

Function number	Setting value	Setting description	Factory setting
44	00	A	◆
	01	B	
	02	C	
	03	D	

15) External input control

"Operation/Stop" mode or "Forced stop" mode can be selected.

Function number	Setting value	Setting description	Factory setting
46	00	Operation/Stop mode 1	◆
	01	(Setting prohibited)	
	02	Forced stop mode	
	03	Operation/Stop mode 2	

16) Room temperature sensor switching (Aux.)

To use the temperature sensor on the wired remote controller only, change the setting to "Wired remote controller" (01).

This function will only work if the function setting 42 is set at "Both" (01).

When the setting value is set to "Both" (00), more suitable control of the room temperature is possible by setting function setting 30 and 31 too.

Function number	Setting value	Setting description	Factory setting
48	00	Both	◆
	01	Wired remote controller	

17) Indoor unit fan control for energy saving for cooling

Enables or disables the power-saving function by controlling the indoor unit fan rotation when the outdoor unit is stopped during cooling operation.

Function number	Setting value	Setting description	Factory setting
49	00	Disable	
	01	Enable	◆

00: When the outdoor unit is stopped, the indoor unit fan operates continuously following the setting on the remote controller.

01: When the outdoor unit is stopped, the indoor unit fan operates intermittently at a very low speed.

18) Primary and secondary settings

Set the indoor unit that is connected to the outdoor unit using a transmission cable as the primary.

Function number	Setting value	Setting description	Factory setting
51	00	Primary	◆
	01	Secondary	

8-7. Wired remote controller (UTY-RNNGM)

DIP switch 1	SW1	Prohibited
	SW2	Dual remote controller setting
	SW3	Prohibited
	SW4	°F/°C switch
	SW5	Prohibited
	SW6	Memory backup setting

* Do not use DIP switch 2.

Switch location

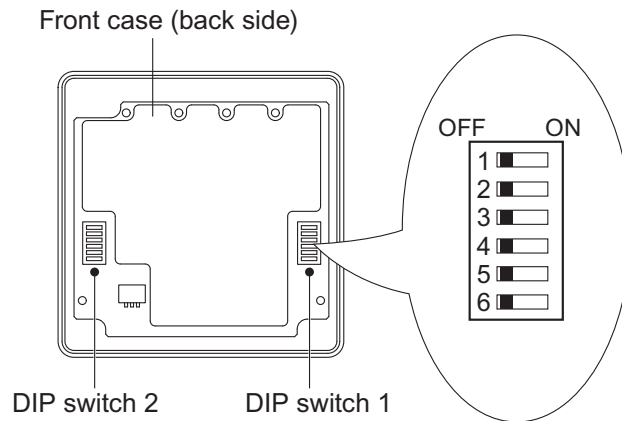

DIP switch 1 setting

● SW2: Dual remote controller setting

Set the remote controller SW2 according to the following table.

Number of remote controller	Primary unit	Secondary unit	Factory setting
	SW2	SW2	
1 (Normal)	OFF	—	◆
2 (Dual)	OFF	ON	

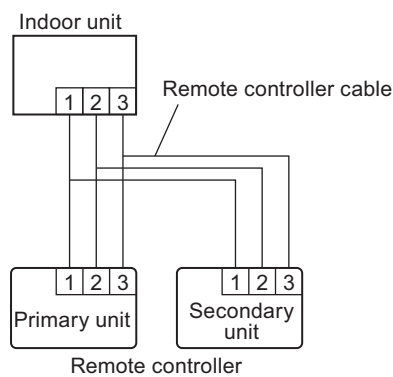

● SW4: Switching temperature unit °F / °C

Displayed temperature unit can be switched between Fahrenheit (°F) and Celsius (°C).

SW4	Fahrenheit (°F) / Celsius (°C)	Factory setting
OFF	°C	◆
ON	°F	

● SW6: Memory backup setting

Set to "ON" to use batteries for the memory backup.

When batteries are not used, all of settings stored in memory will be deleted if there is a power failure.

SW6	Memory backup	Factory setting
OFF	Disable	◆
ON	Enable	

8-8. Wired remote controller (UTY-RVNGM)

DIP switch 1	SW1	Memory backup setting
	SW2	Dual remote controller setting

■ Switch location

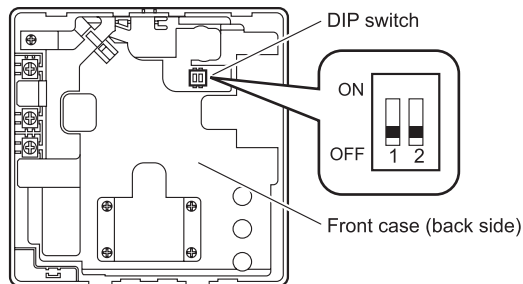

■ DIP switch setting

● SW1: Memory backup setting

Set to "ON" to use batteries for the memory backup.

When batteries are not used, all of settings stored in memory will be deleted if there is a power failure.

SW1	Memory backup	Factory setting
OFF	Disable	◆
ON	Enable	

● SW2: Dual remote controller setting

Set the remote controller SW2 according to the following table.

Number of remote controller	Primary unit	Secondary unit	Factory setting
	SW2	SW2	
1 (Normal)	OFF	—	◆
2 (Dual)	OFF	ON	

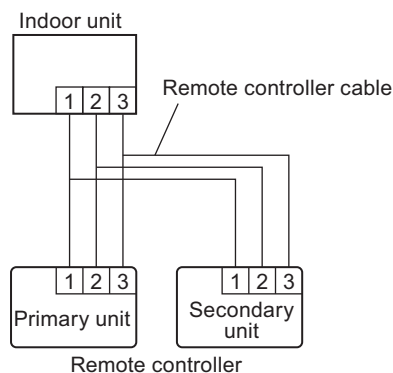

8-9. Simple remote controller (UTY-RSNGM)

DIP switch	SW1	Prohibited
	SW2	Dual remote controller setting
	SW3	°F/°C switch
	SW4	Prohibited
	SW5	Prohibited
	SW6	Prohibited

Switch location

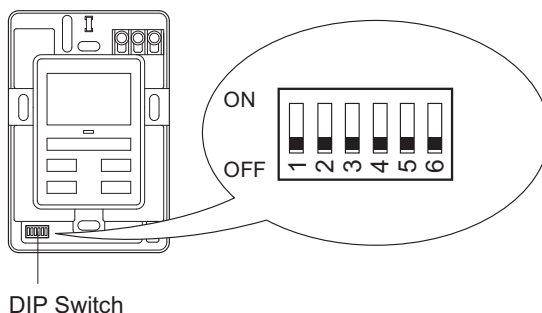

DIP switch setting

● SW2: Dual remote controller setting

Set the remote controller SW2 according to the following table.

Number of remote controller	Primary unit	Secondary unit	Factory setting
	SW2	SW2	
1 (Normal)	OFF	—	◆
2 (Dual)	OFF	ON	

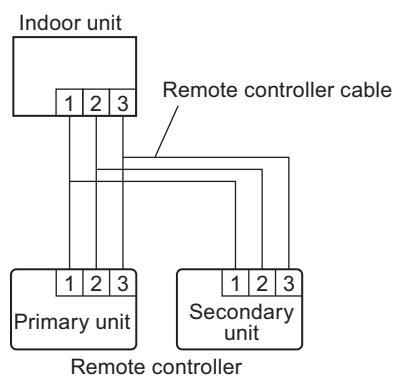

● SW3: Switching temperature unit °F / °C

Displayed temperature unit can be switched between Fahrenheit (°F) and Celsius (°C).

SW3	Fahrenheit (°F) / Celsius (°C)	Factory setting
OFF	°C	◆
ON	°F	

9. Check and test

9-1. Test run

■ Pre-test run check items

Check column	Check item
	Is the outdoor unit securely installed?
	Have you performed gas leakage inspection? (Connection joints of various pipes (flange connection, brazing))
	Is the heat insulation done completely? (Gas pipe, liquid pipe, drain hose extension on indoor unit side etc)
	Is the water discharging from drain without any problems?
	Are the cables connected correctly?
	Are the cables as per specifications?
	Is the earth wire connected accurately?
	Are there any obstacles blocking the suction gate, and outlet of the indoor/outdoor units?
	Have you filled the specified amount of refrigerant?
	Are the stop valves of gas pipe and liquid pipe fully open?
	Has the power been supplied to crankcase heater for more than 6 hours?

■ Test operation method

Be sure to configure test run settings only when the outdoor unit has stopped operating.

Notices:

- Depending on the communication status between the indoor and outdoor units, it may take several minutes for the system to start operating after settings for the test run are complete.
- After the test run settings are complete, the outdoor units and the connected indoor units will start operating. Room temperature control will not activate during test operation (continuous operation).
- If a knocking sound can be heard in the liquid compression of the compressor, stop the unit immediately and then energize the crank case heater for a sufficient length of time before restarting the operation.

Test operation setting method (It can be performed in the following two ways)

- Set with test operation setting (refer to installation instructions manual of indoor unit for further details) available in the remote controller.
- "Cooling operation" and "Heating operation" can be set using SELECT button and ENTER button available on the board of display unit.
(*Make sure to perform the first test operation with cooling operation.)

Set as per the procedure given below.

Symbols in the following table indicate LED status.

"○": Lights off, "●": Lights on

1. Turn on the power of the outdoor unit and enter standby mode.
"POWER/MODE" Lamp lights up.

POWER MODE	ERROR	PUMP DOWN (L1)	LOW NOISE (L2) (L3)		PEAK CUT (L4) (L5) (L6)		
●	○	○	○	○	○	○	○

2. Press the ENTER button for more than 3 seconds.

POWER	ERROR	PUMP DOWN (L1)	LOW NOISE		(L4)	PEAK CUT		(L6)
MODE			(L2)	(L3)		(L5)		
Blink	○	○	○	Blink	○	○	○	

3. Press the SELECT button, LED of the test run mode Switched between "COOL " and "HEAT".

- Cooling test mode

POWER	ERROR	PUMP DOWN (L1)	LOW NOISE		(L4)	PEAK CUT		(L6)
MODE			(L2)	(L3)		(L5)		
Blink	○	○	○	Blink	○	○	○	

- Heating test mode

POWER	ERROR	PUMP DOWN (L1)	LOW NOISE		(L4)	PEAK CUT		(L6)
MODE			(L2)	(L3)		(L5)		
Blink	○	○	Blink	○	○	○	○	

4. After confirming the operation mode, Press ENTER button. The display changes as follows, and Air conditioner starts operation.

- Cooling test mode

POWER	ERROR	PUMP DOWN (L1)	LOW NOISE		(L4)	PEAK CUT		(L6)
MODE			(L2)	(L3)		(L5)		
Blink	○	○	○	●	○	○	○	

- Heating test mode

POWER	ERROR	PUMP DOWN (L1)	LOW NOISE		(L4)	PEAK CUT		(L6)
MODE			(L2)	(L3)		(L5)		
Blink	○	○	●	○	○	○	○	

5. Press [ENTER] button.

Air conditioner stopped operation.

POWER	ERROR	PUMP DOWN (L1)	LOW NOISE		(L4)	PEAK CUT		(L6)
MODE			(L2)	(L3)		(L5)		
●	○	○	○	○	○	○	○	

■ Checklist

Check items during test operation.

Check column	Check item
	Is the outdoor unit making any abnormal noise or vibrating significantly?
	Is the cold air or hot air blowing from indoor unit according to the operation mode?
	Check that the "ERROR" LED blinks. If, it has displayed, check the error content refer to Error code check table.
	Operate the unit according to the operating manual provided with the indoor unit, and check that it is operating normally.

9-2. Error code

If an error occurs, the LED will light up to display the error location and the error code.

■ Error display mode

Display when an error occurs.

POWER MODE	ERROR	PUMP DOWN (L1)	LOW NOISE (L2) (L3)			PEAK CUT (L4) (L5) (L6)	
●	Blink (Hi speed)	○	○	○	○	○	○

Sign "○": Lights off, "●": Lights on

NOTE: Check that the "ERROR" LED blinks, then press the [ENTER] button once.

■ Error code check table

POWER/ MODE	ERROR	LED display						Description	Remark
		PUMP DOWN (L1)	LOW NOISE (L2) (L3)		PEAK CUT (L4) (L5) (L6)				
◆(2)	●	◆(1)	◆(1)	○	○	●	●	Serial communication error	Serial forward transmission error immediately after operation
◆(2)	●	◆(1)	◆(1)	○	●	○	○		Serial forward transmission error during operation
◆(2)	●	◆(2)	◆(2)	○	○	○	●	Indoor unit capacity error	Indoor unit capacity error
◆(2)	●	◆(5)	◆(15)	○	○	○	●	Indoor unit error	Indoor unit error
◆(2)	●	◆(6)	◆(2)	○	○	○	●	Outdoor unit main PCB error	Outdoor unit PCB model information error
◆(2)	●	◆(6)	◆(3)	○	○	○	●	Inverter PCB error	Inverter error
◆(2)	●	◆(6)	◆(5)	○	○	●	●	IPM error	Trip terminal L error
◆(2)	●	◆(7)	◆(1)	○	○	○	●	Discharge temp. sensor error	Discharge temp. sensor 1 error
◆(2)	●	◆(7)	◆(2)	○	○	○	●	Compressor temp. sensor error	Compressor temp. sensor 1 error
◆(2)	●	◆(7)	◆(3)	○	○	●	○	Outdoor unit Heat Ex. sensor error	Heat Ex. middle temp. sensor error
◆(2)	●	◆(7)	◆(3)	○	○	●	●		Outdoor unit Heat Ex. liquid temp. sensor error
◆(2)	●	◆(7)	◆(4)	○	○	○	●	Outdoor temp. sensor error	Outdoor temp. sensor error
◆(2)	●	◆(7)	◆(7)	○	○	○	●	Heat sink temp. sensor error	Heat sink temp. sensor error
◆(2)	●	◆(8)	◆(4)	○	○	○	●	Current sensor error	Current sensor 1 error (stoppage permanently)
◆(2)	●	◆(8)	◆(6)	○	●	○	○	Pressure sensor error	High pressure switch 1 error
◆(2)	●	◆(8)	◆(6)	○	○	○	●		Outdoor unit discharge pressure sensor error
◆(2)	●	◆(8)	◆(6)	○	○	●	●		Outdoor unit suction pressure sensor error
◆(2)	●	◆(9)	◆(4)	○	○	○	●	Trip detection	Trip detection
◆(2)	●	◆(9)	◆(5)	○	○	○	●	Compressor motor control error	Rotor position detection error (stoppage permanently)
◆(2)	●	◆(9)	◆(7)	○	○	●	●	Outdoor unit fan motor 1 error	Duty error
◆(2)	●	◆(9)	◆(8)	○	○	●	●	Outdoor unit fan motor 2 error	Duty error
◆(2)	●	◆(9)	◆(9)	○	○	○	●	4-way valve error	4-way valve error
◆(2)	●	◆(10)	◆(1)	○	○	○	●	Discharge temp. 1 error	Discharge temp. 1 error
◆(2)	●	◆(10)	◆(3)	○	○	○	●	Compressor temp. error	Compressor 1 temp. error
◆(2)	●	◆(10)	◆(5)	○	○	○	●	Pressure error 2	Low pressure error

Display mode ●: Lights on
○: Lights off
◆: Blink (0.5s Lights on / 0.5s Lights off)
(): Number of flashing

9-3. Pump down

⚠ WARNING

- Never touch electrical components such as the terminal blocks except the button on the display board. It may cause a serious accident such as electric shock.
- During the pump-down operation, make sure that the compressor is turned off before you remove the refrigerant piping.
Do not remove the connection pipe while the compressor is in operation with 2-way or g. 3-way valve open. This may cause abnormal pressure in the refrigeration cycle that leads to breakage and even injury.

⚠ CAUTION

- Perform the pump down operation before disconnecting any refrigerant pipe or electric cable.
- Collect refrigerant from the service port or the 3-way valve if pump down cannot be performed.
- In case of a group control system installation, do not turn the power off until pump down is completed in all outdoor units.
(Group control system installation described in "SPECIAL INSTALLATION METHODS" in the installation manual of the indoor unit.)

■ Pump down procedure

Confirm that the power is off, and then open the service panel.

Symbols in the following table indicate LED status.

"○": Lights off, "●": Lights on

1. Check the 3-way valves (both the liquid side and gas side) are opened.
2. Turn the power on.

POWER	ERROR	PUMP	LOW			PEAK		
MODE		DOWN	NOISE			CUT		
		(L1)	(L2)	(L3)	(L4)	(L5)	(L6)	
●	○	○	○	○	○	○	○	

3. Press [PUMP DOWN] button for 3 seconds or more after 3 minutes after power on.

POWER	ERROR	PUMP	LOW			PEAK		
MODE		DOWN	NOISE			CUT		
		(L1)	(L2)	(L3)	(L4)	(L5)	(L6)	
●	○	●	○	○	●	●	●	

LED display lights on as shown in the above figure, and the fans and the compressor start operating.

NOTE: If the [PUMP DOWN] button is pressed during compressor operation, the compressor will stop, and the operation will start after about 3 min.

4. LED display will change as shown below about 3 minutes after the compressor starts. Fully close the 3-way valve on the liquid pipe side at this stage.

POWER	ERROR	PUMP	LOW			PEAK		
MODE		DOWN	NOISE			CUT		
		(L1)	(L2)	(L3)	(L4)	(L5)	(L6)	
●	○	●	○	○	○	●	●	

NOTE: If the valve on the liquid pipe side is not closed, the pump down cannot be performed.

- When LED display changes as shown in the below figure, close the 3-way valve on the gas pipe side tightly.

POWER	ERROR	PUMP DOWN (L1)	LOW NOISE		PEAK CUT		
MODE			(L2)	(L3)	(L4)	(L5)	(L6)
●	○	●	○	○	○	○	●

NOTE: If the valve on the gas pipe side is not closed, refrigerant may flow into the piping after the compressor stops.

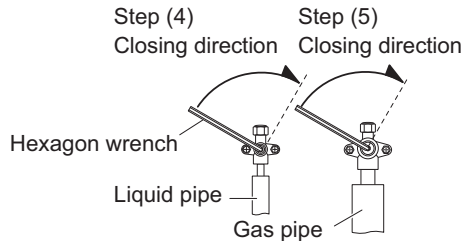

- LED display changes after 1 minute as shown in the figure below. The LED will light as follows.

POWER	ERROR	PUMP DOWN (L1)	LOW NOISE		PEAK CUT		
MODE			(L2)	(L3)	(L4)	(L5)	(L6)
●	○	●	○	○	○	○	○

Fans and compressor stop automatically.

NOTE: If the pump down is successfully completed (the above LED display is shown), the outdoor unit remains stopped until the power is turned off.

- Turn the power off.

POWER	ERROR	PUMP DOWN (L1)	LOW NOISE		PEAK CUT		
MODE			(L2)	(L3)	(L4)	(L5)	(L6)
○	○	○	○	○	○	○	○

Pump down is completed.

NOTES:

- To stop pump down, press the [PUMP DOWN] button again.
- To start the pump down again after the compressor is automatically stopped due to an error, disconnect the power supply and open the 3-way valves. Wait 3 minutes, reconnect the power supply and start the pump down again.
- When starting the operation after completion of the pump down, disconnect the power supply, and then open the 3-way valves. Wait 3 minutes, reconnect the power supply and perform a test run in the “COOL” operation mode.
- If an error occurs, recover the refrigerant from service port.

10. Optional parts installation

10-1. Drain pump unit for duct type (UTZ-PX1NBA)

■ Specifications

	Unit	Specifications
Height of drain up	mm	Maximum 1000
Power source	—	220—240 V, 50/60 Hz
Power input (230 V, 50/60 Hz)	W	12/10.8
Current (230 V, 50/60 Hz)	mA	114/92
Dimensions (H × W × D)	mm	176 × 178 × 154
Weight	kg	2.5
Connection pipe diameter	—	VP25 (I.D.25 mm, O.D.32 mm)
Direction of pipe connection*1	—	360°
Angle of pipe connection *2	—	0° (Horizontal)—90°(Vertical)
Control method	—	Control board of indoor unit
Safety device	—	Float switch, Thermal fuse

*1: Direction of pipe connection

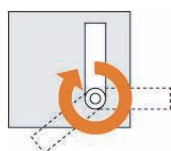

*2: Angle of pipe connection

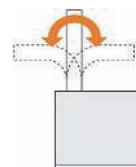

■ Applicable indoor units

Type	Model name
Duct type	ARHG22LMLA, ARHG24LMLA, ARHG30LMLE, ARHG36LMLE, and ARHG45LMLA

■ Installation place

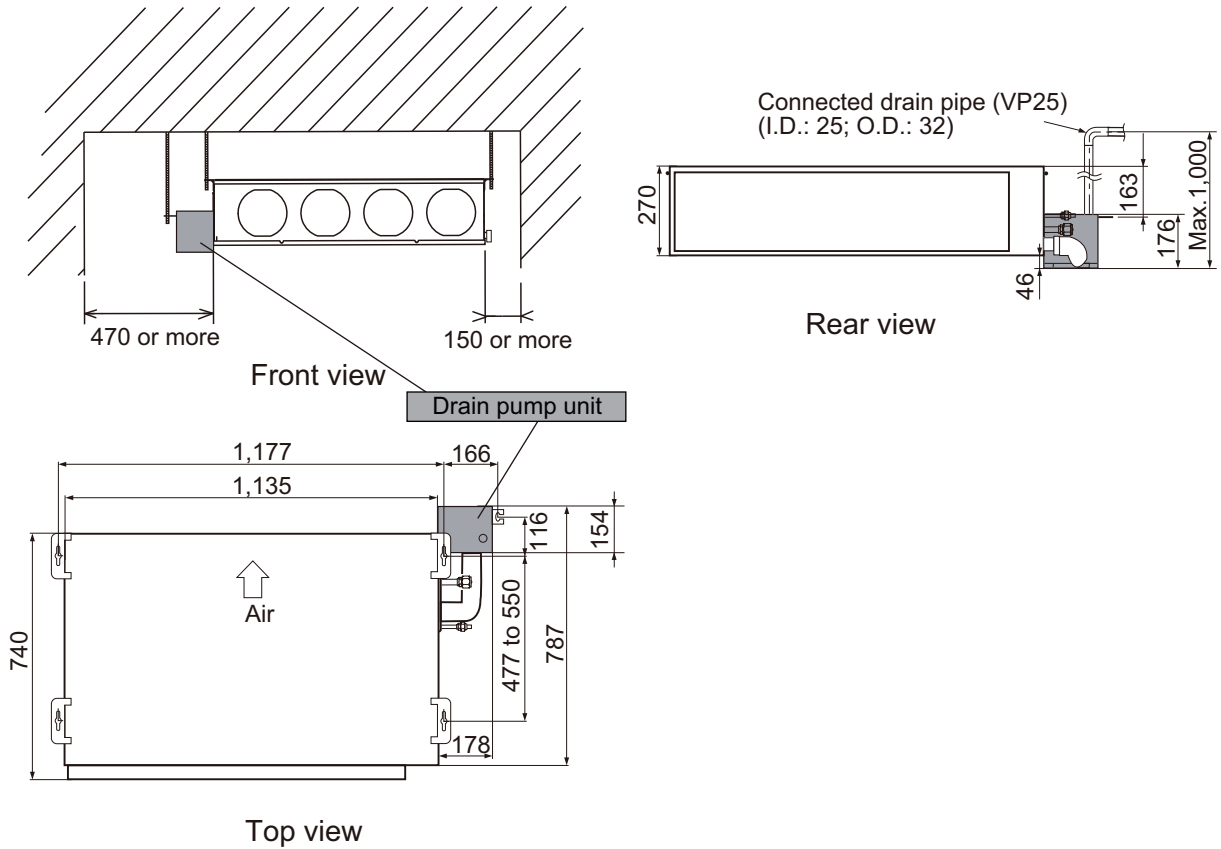

NOTES:

- Leave the space required to service the unit.
- Set a maintenance hole near the drain pump unit.

■ Installing drain pump unit

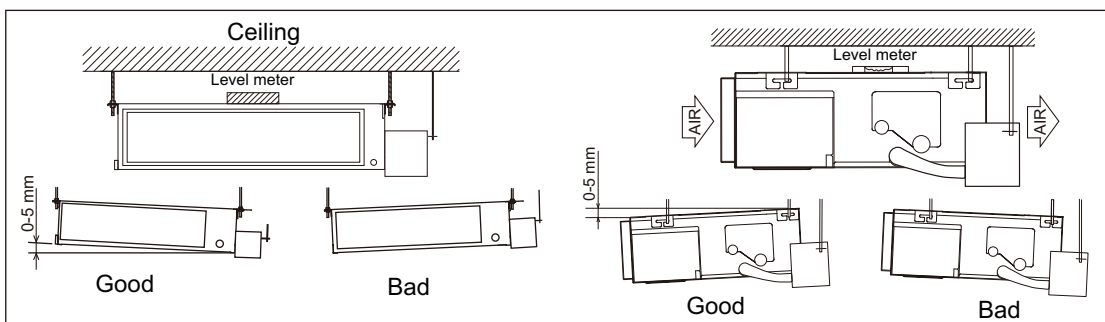
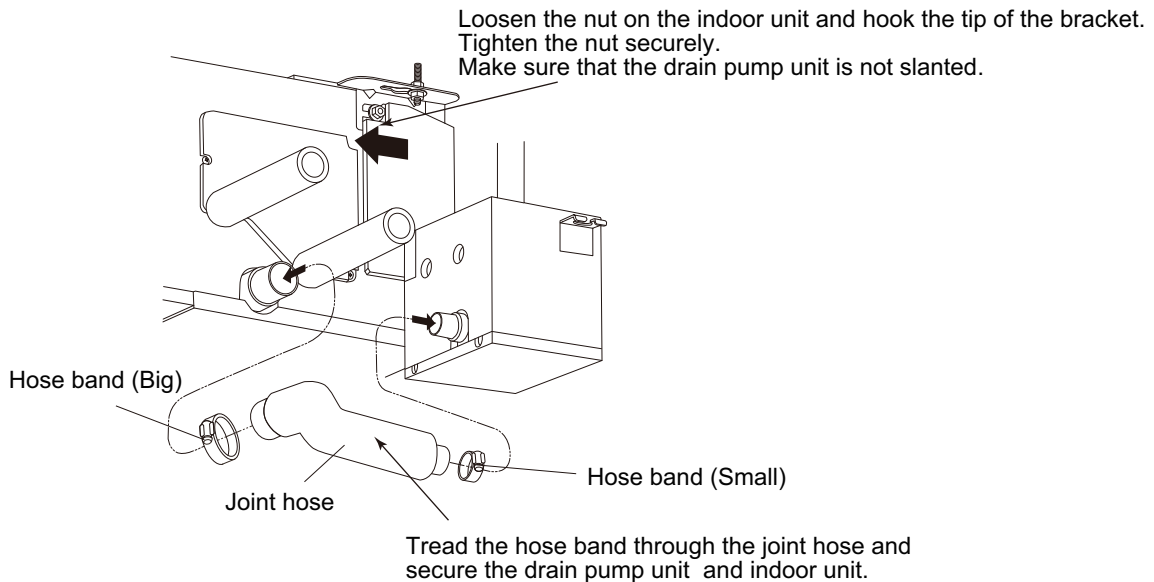

■ Installing hose

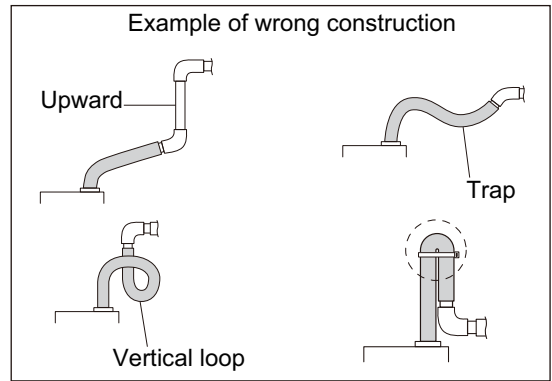
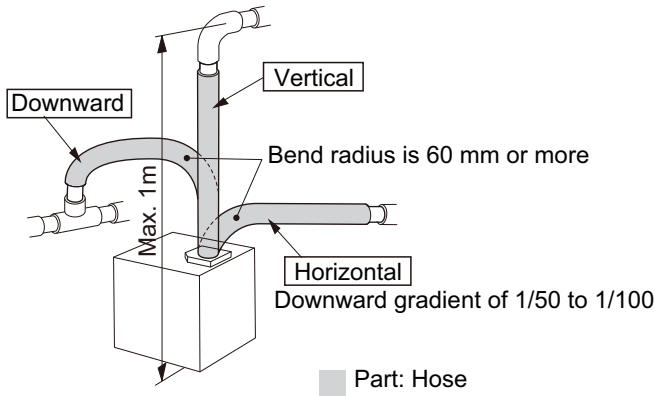

■ Installing pipe

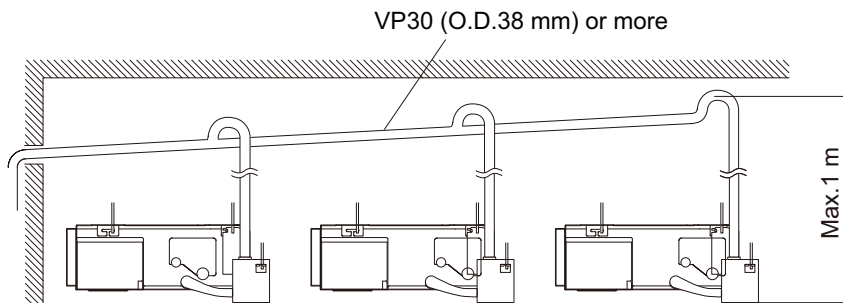
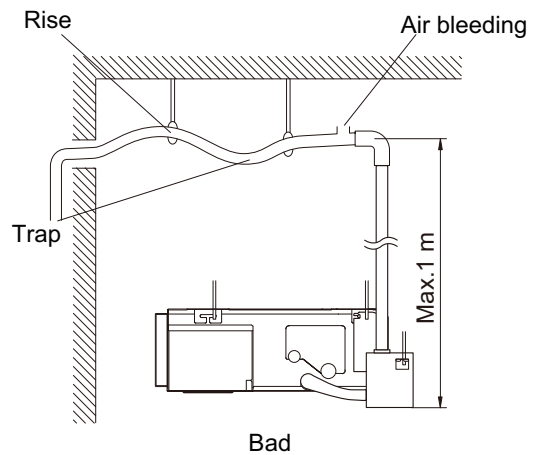
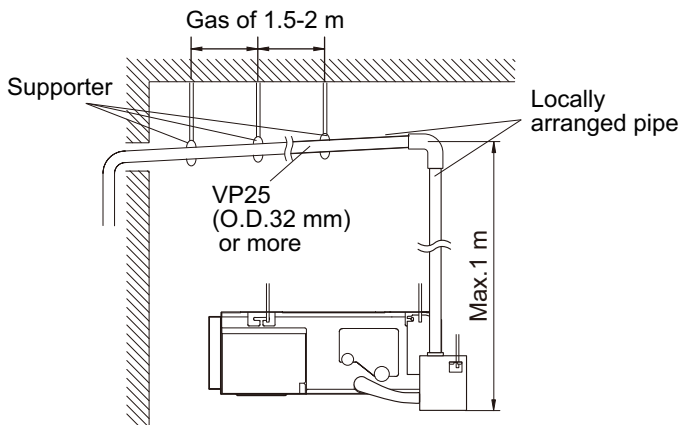

For construct centralized drain pipe fittings, refer to the electrical wiring.

■ Electrical wiring

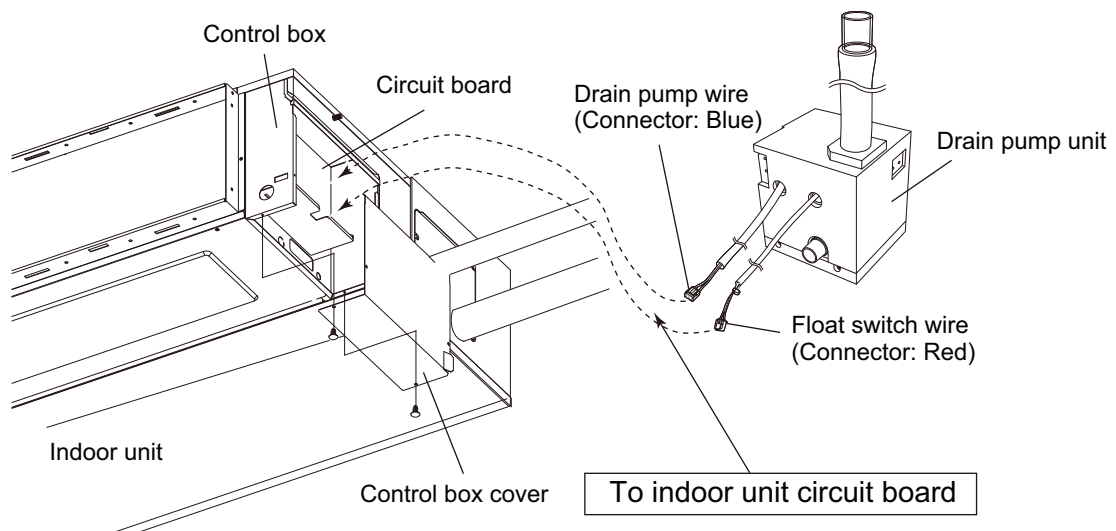

10-2. Drain pump unit for ceiling type (UTR-DPB24T)

■ Applicable indoor units

Type	Model name
Ceiling type	ABHG30LRTE, ABHG36LRTE, and ABHG45LRTA

■ Installing drain pump unit and electrical wiring

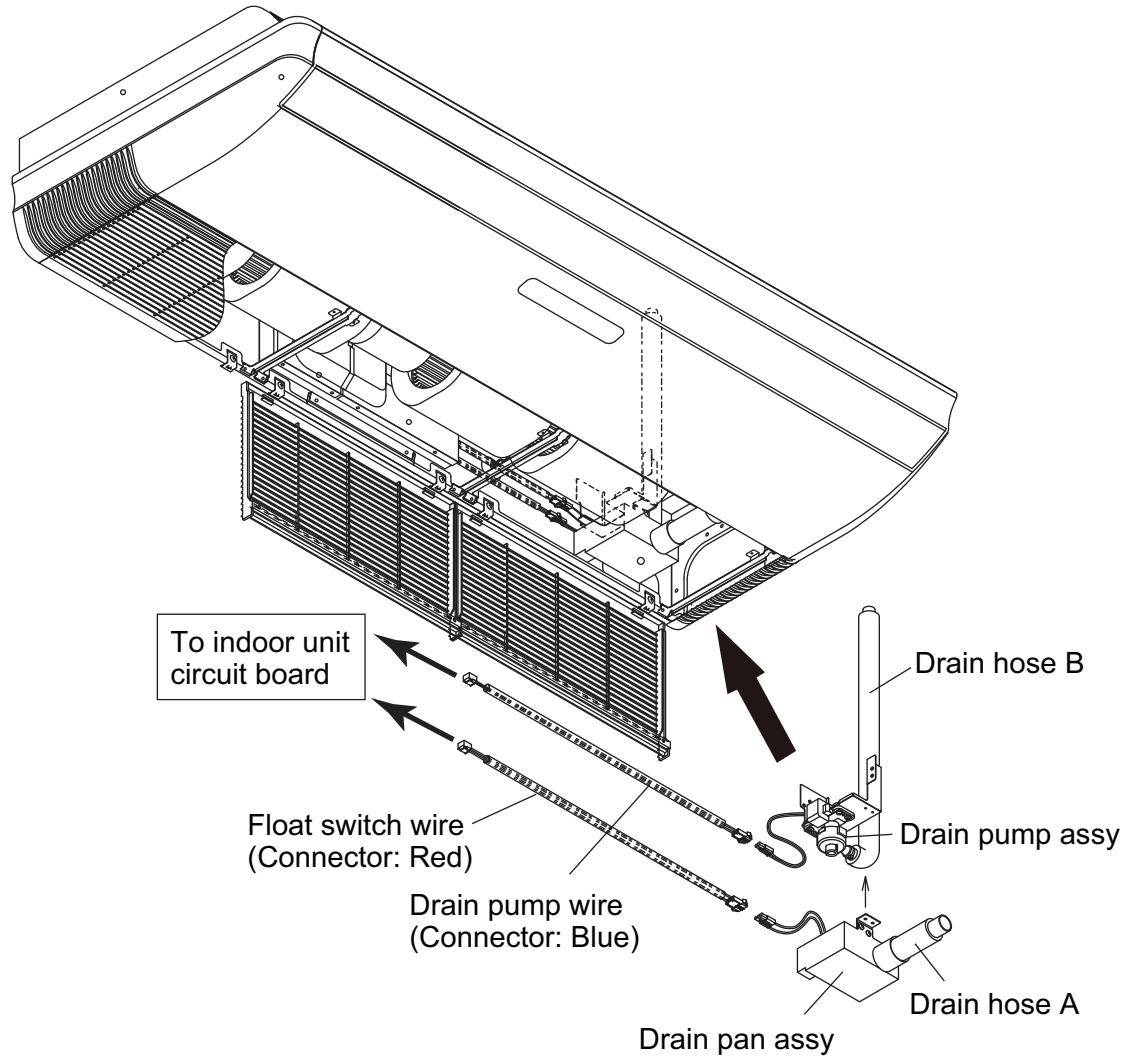

■ Installing pipe

- Set up the drain hose for a maximum rise 500 mm and give the drain pipe a downward gradient of 1/25 to 1/100.
- Install the drain pipe so there is no rise, trap, or air bleed.

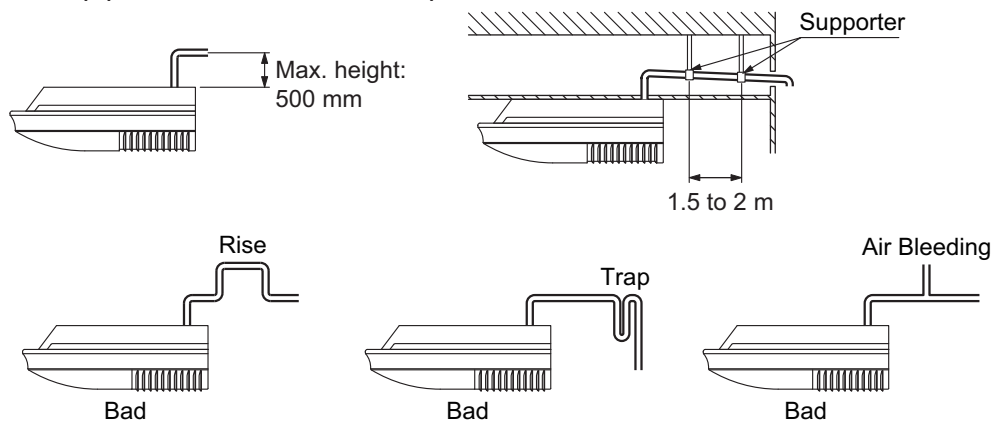

10-3. Fresh air intake kit for cassette type (UTZ-VXRA)

■ Specifications

Model name				UTZ-VXRA	
Fresh air intake	Max. fresh air intake volume	2-way intake	%	10	
		1-way intake	(For High)	5	
Connection duct type			mm	Φ 100	
			Pcs	2	
Dimensions (H × W × D)		Net	kg	120 × 840 × 840	
		Gross		165 × 860 × 860	
Weight		Net	kg	6.0	
		Gross		9.5	

■ Dimensions

Unit: mm

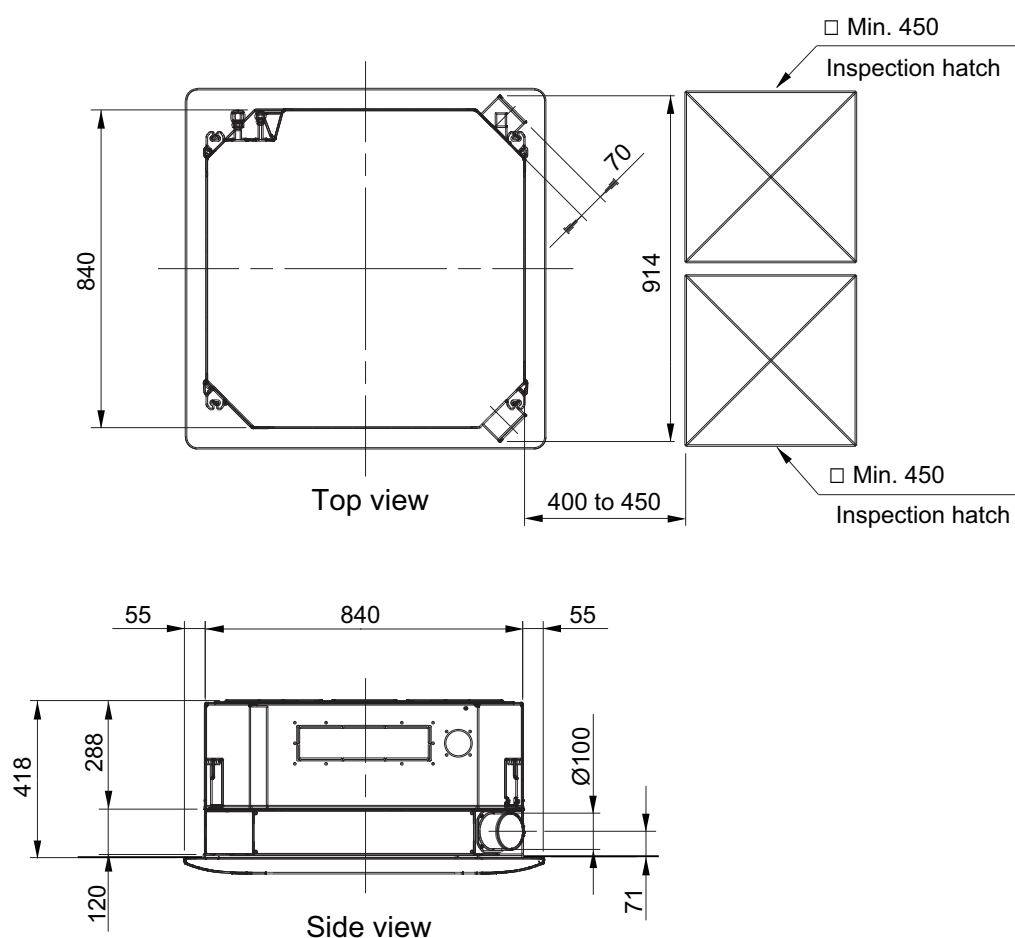

NOTE: When installing this kit, inspection hatch is necessary. (It is necessary when servicing.) Either one of inspection hatches must be installed.

Airflow

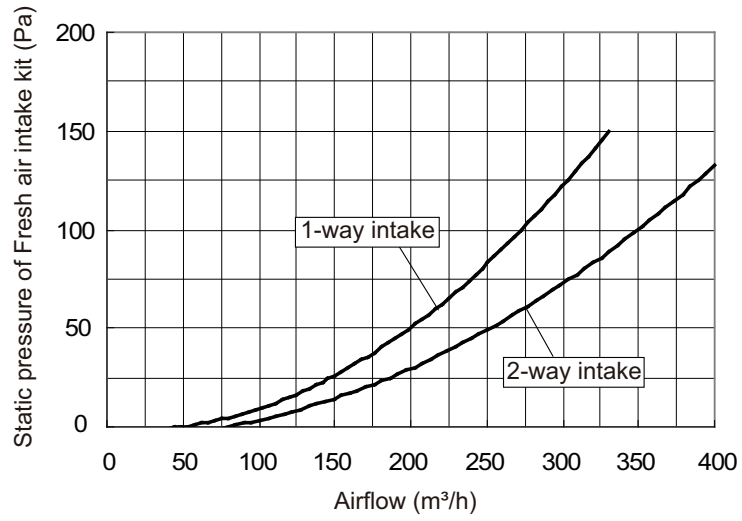

Unit: mm

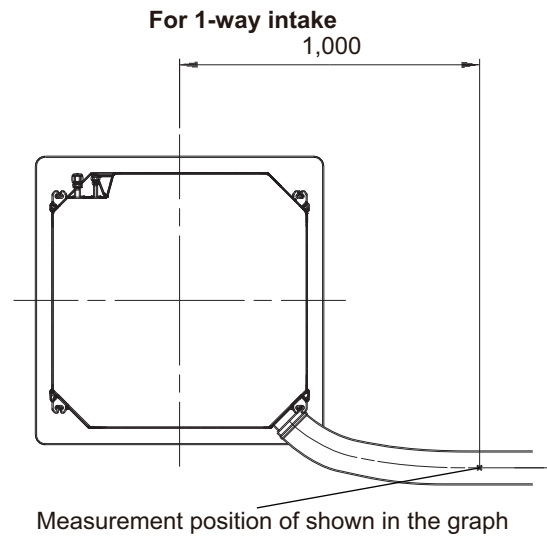
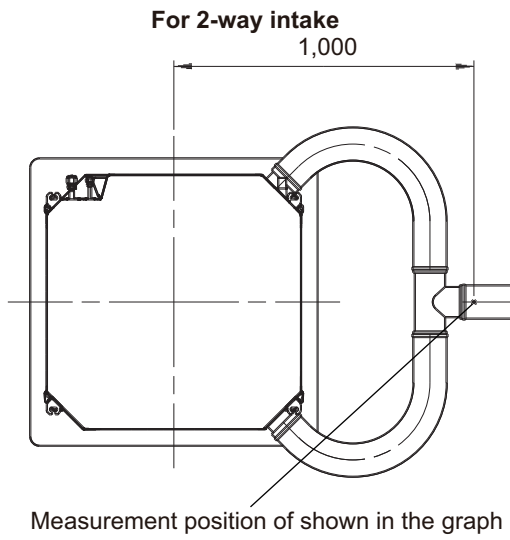

■ Fresh air control output

- You can control duct fan by synchronization with fan operation of indoor unit.
- Wire for fresh air control output is supplied with Fresh air intake kit.

• Connection diagram

For Relay

Output voltage: DC 12 V

Permissible current: 15 mA

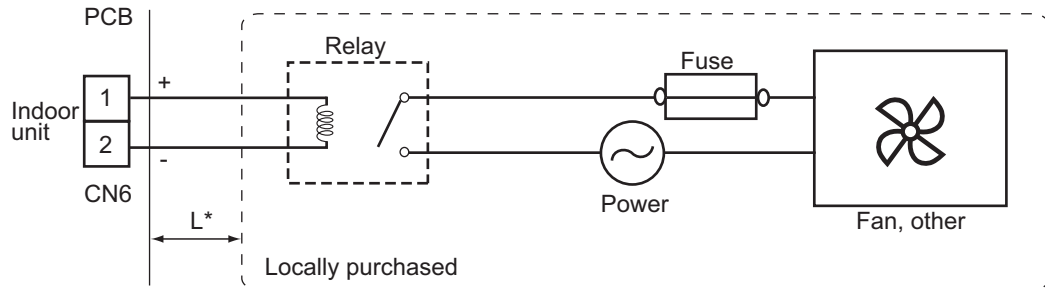

*: Make the distance from the PCB to the Relay unit within 10 m.



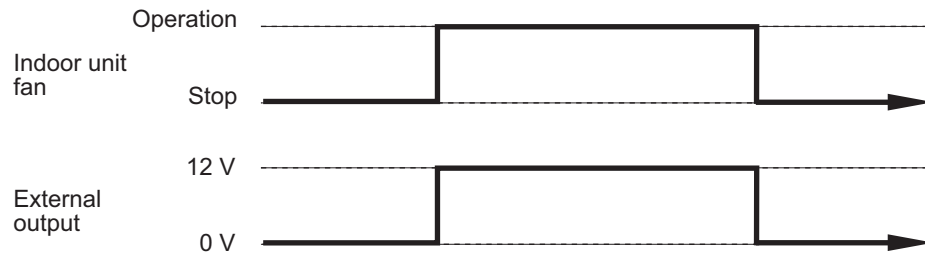



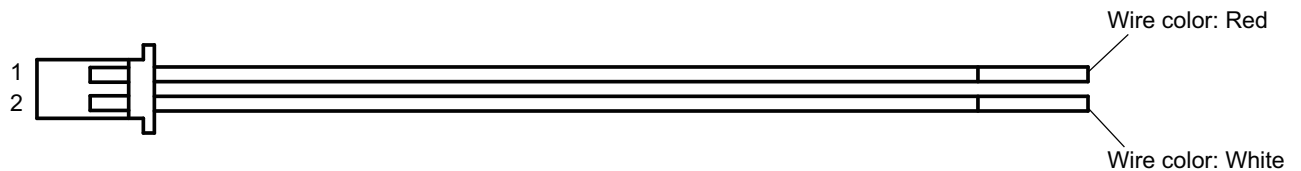





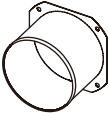

• Operation status

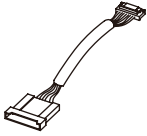
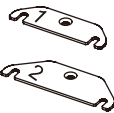

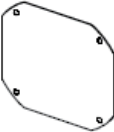
• Wire (External output 1)

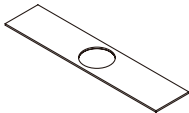

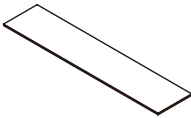
■ Accessories

Part name	Exterior	Q'ty	Part name	Exterior	Q'ty
Installation manual		1	Insulation 4		4
Duct flange		2	Cable tie		1
Cover		2	Extension wire for louver		1 set
Screw		16	Extension wire for receiver kit		1
Hook plate		2 set	Wire (External output 1)		1
Shutter plate		1	Wire (External output 2)		1
Insulation 1		2	Wire (External output 3)		1
Insulation 2		1	Bolt		4
Insulation 3		3			

■ Installation precautions

- **About Fresh air intake kit**
 - The Fresh air intake kit can be installed onto cassette type air conditioners.
 - The volume of ventilated air provided by the Fresh air intake kit may be unable to fulfill ventilation regulations in all countries. On such occasions we ask that this kit be used along with Energy recovery ventilators.
 - When intaking outside air, ensure correct air conditioning design as based on air conditioning load calculations. As outside air is not being processing an increase in outside air load can affect air conditioning.
- **Installation location**
 - Area that generated substances that adversely affect the equipment, such as sulfuric gas, chlorine gas, acid, or alkali it will cause the copper pipes and brazed joints to corrode, which can cause refrigerant leakage.
 - Area with high salt content, such as at the seaside. It will deteriorate metal parts, causing the parts to fall or the unit to leak water.
 - Be certain to use electric dampers and shutters to avoid infiltration of cold air, wind and fog during shutdown in areas with cold climate, strong winds, or where fogs are common.
 - Ensure the product is installed a distance of at least three times the duct diameter away from exterior wall air inlets, or air exhausts for the prevention of short circuits.
- **Temperature conditions**
 - Condensation may form on the product when outside air temperature is low and the temperature and humidity surrounding the product are high. Do not intake the air of below 0 °C into the Fresh air intake kit.
 - Do not take fresh air at a temperature that exceeds the upper limit of the operation temperature range of the outdoor unit.
- **About duct fan**
 - When installing the duct fan, connect the drive relay (locally purchased) and operate with the indoor unit.
 - Ensure the intake air volume is below 10 % of the product's air volume High. When the intake air volume becomes too large there the operating noise may increase and room temperature detection may be affected.
- **About the duct connection**
 - Purchase a duct with internal diameter that fits the external diameter of the duct flange.
 - Note that regulations of some countries may require the use of a nonflammable duct.
 - If the duct penetrates a fire-retarding division or other fire-proofing measures, the installation of fire dampers, or a construction that does not adversely affect fire control measure is a regulatory requirement of some countries.
 - When using metallic ducts, ensure metals (i.e., metal lath, wire lath, stainless sheeting) are electrically insulated. (A short occurring by electrical connection can cause fire.)
 - Ensure the thermally insulate connected ducts to prevent condensation.
 - Make certain that netting or other measures are installed in parts exposed to the outside air to prevent infiltration of small animals such as birds and insects.
 - Be certain to install external air filters to parts exposed to the outside air for heat exchanger protection of indoor equipment.
 - Avoid the infiltration of rain water by installing outside ducts with an incline of at least 1/30, and fitting hoods on openings.

■ Installation

● Mounting of indoor unit

- For mounting, refer to the installation manual provided with indoor unit.
- When installing this product to existing indoor units, adjust the installation height of the indoor units to height 260 to 265 mm as shown below.

Unit: mm

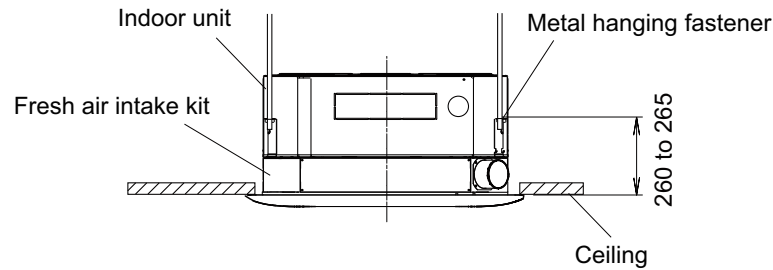

● Pre-installation preparations

- Attach the duct flange provided with screws.
- The Fresh air intake kit can be used an external air intake on just one side. Use included sealed plate to apply for different eye holes.
- Apply insulation 1 to the installed duct flange parts (Do not apply to sealed areas).

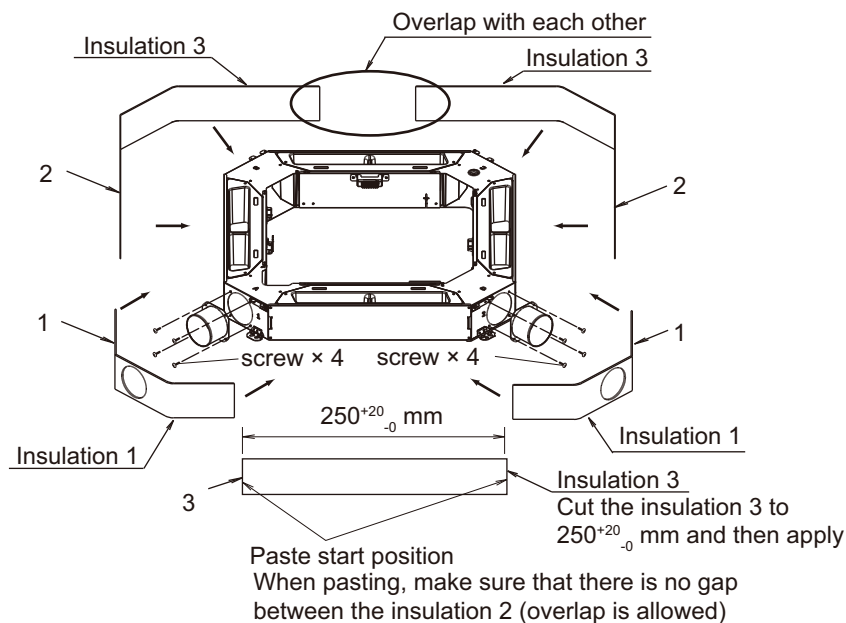

When taking in the air in one side, paste the insulation in the order as shown below.

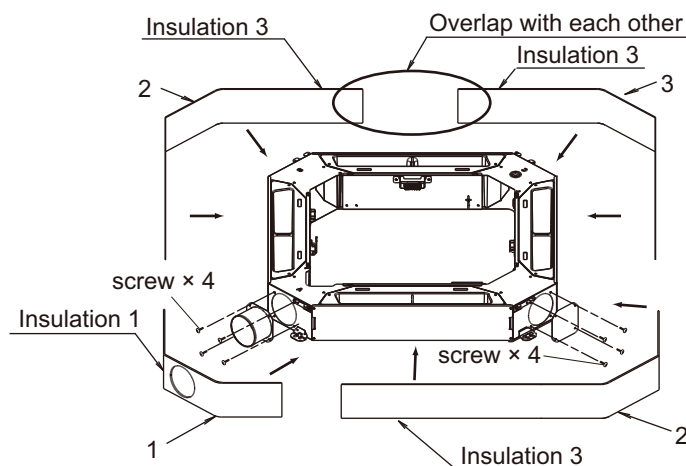

● Installation of Fresh air intake kit

1. Attach the Fresh air intake kit to the main body using the bolts provided.

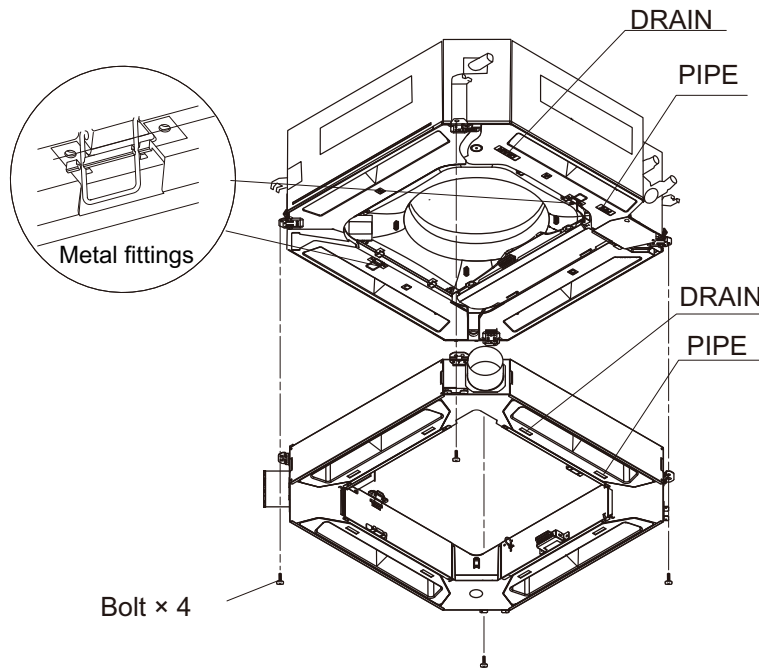

2. Attach the Hook plate by each corner of the Fresh air intake kit. (The attaching screws are attached to the body of the Fresh air intake kit and must be loosened before installing.)

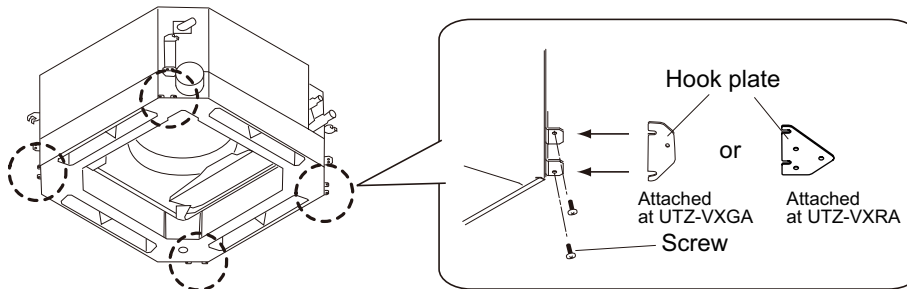

3. Install the cover.

- a. Remove the drain cover attached to the decorative panel and install onto the Fresh air intake kit.

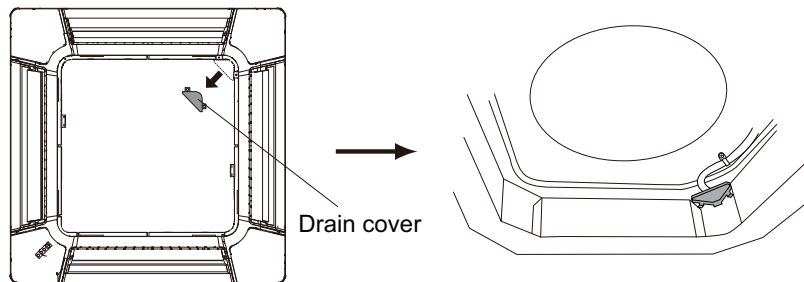

- b. Set the cover in position with screws (2 places) as shown below. Apply the Insulation 4 after installing the cover.

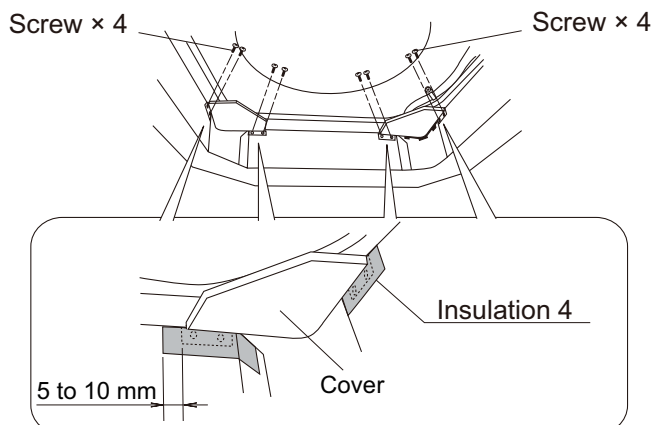

4. Install the duct.

- a. Fasten the connecting parts of the ducts with bands, and wrap with vinyl tape to ensure no air leaks. (Carry out the work to ensure no air leakage at a pressure of 200 Pa.)

NOTE: Do not construct the duct in the manner of below.

- Extreme bends
- Highly repetitive bends
- Making the connecting duct diameters smaller

- b. When using T-shaped pipe, suspend the kit with suspension bands for duct-use to avoid unnecessary load bearing.

Completion figure

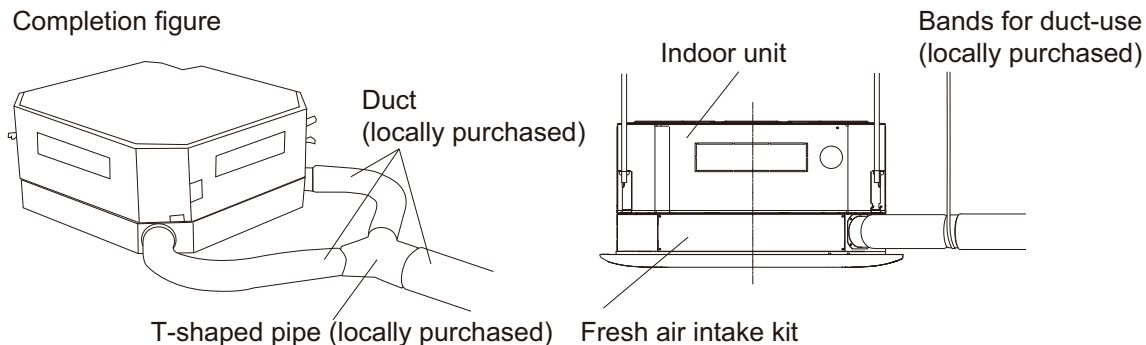

NOTE: When wiring of the duct fan is required, refer to "[Fresh air control output](#)" on page 305.

● Installation of Cassette grille

Pre-installation preparations:

1. Remove the control box cover.
2. Remove the connector from the existing temperature sensor on the circuit board of the indoor unit.

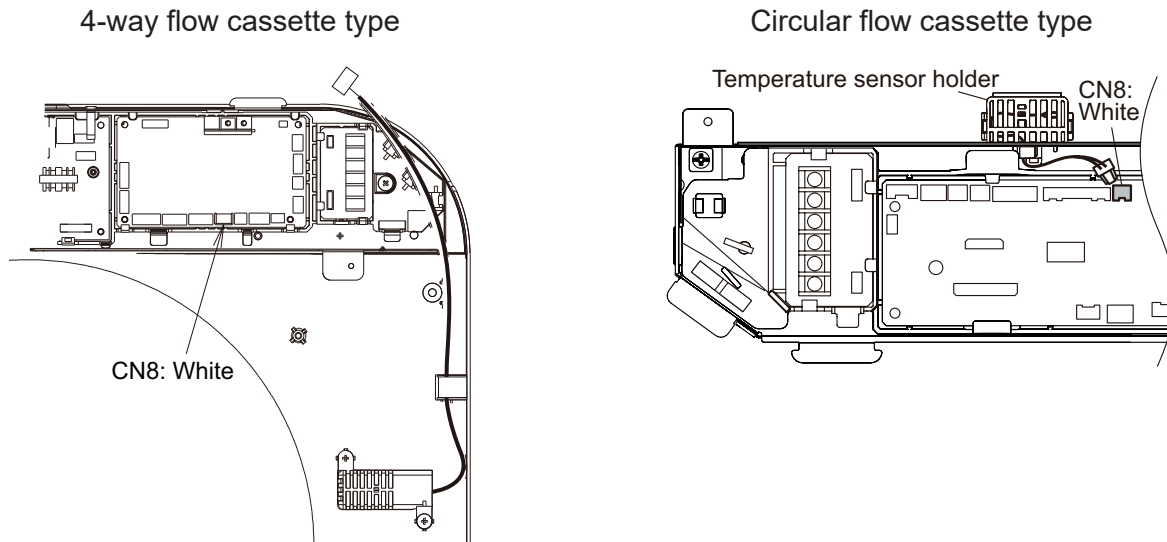

- The existing temperature sensor will not be used so remove it from the sensor holder, and once more install the empty sensor holder (without sensor) in the control box.

⚠ CAUTION

Make sure to install the sensor holder inside the control box, as it is a fire hazard. Otherwise, it may cause fire.

4-way flow cassette type

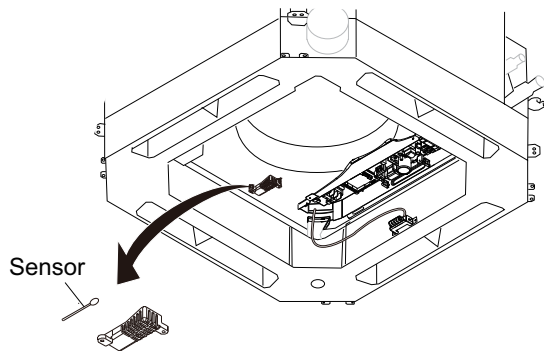

Circular flow cassette type

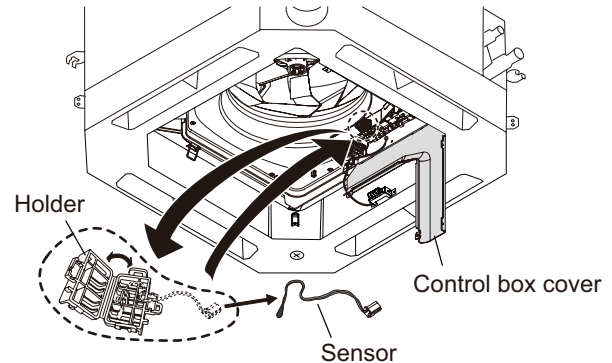

- Insert the connector of the sensor attached to the Fresh air intake kit onto the substrate board of the indoor unit.

4-way flow cassette type

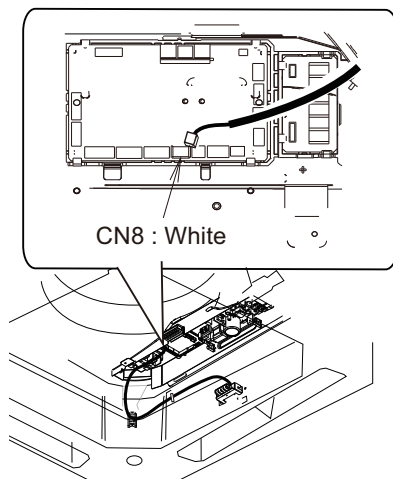

Circular flow cassette type

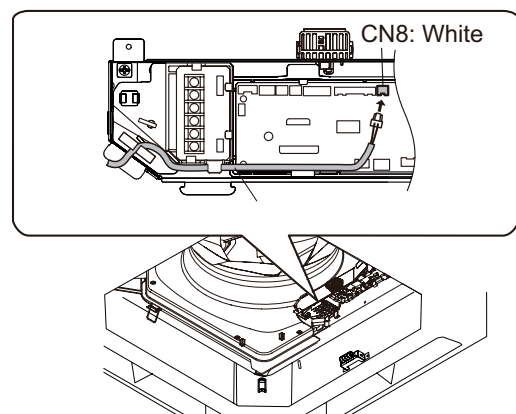

- Insert the included extension cable for use with louver to the connector.
- When using the optical receiver unit (option), insert the included extension wire to the indoor unit.
- Close the control box cover when work is complete.

Installation procedure:

- After provisional fixing of a cassette grille, feed the louver extension wire (and optical receiver extension wire) through the penetrating hole.
- Connect to the connection wires coming out of the cassette grille.

3. Install cassette grille panel according to the installation instruction sheet provided.

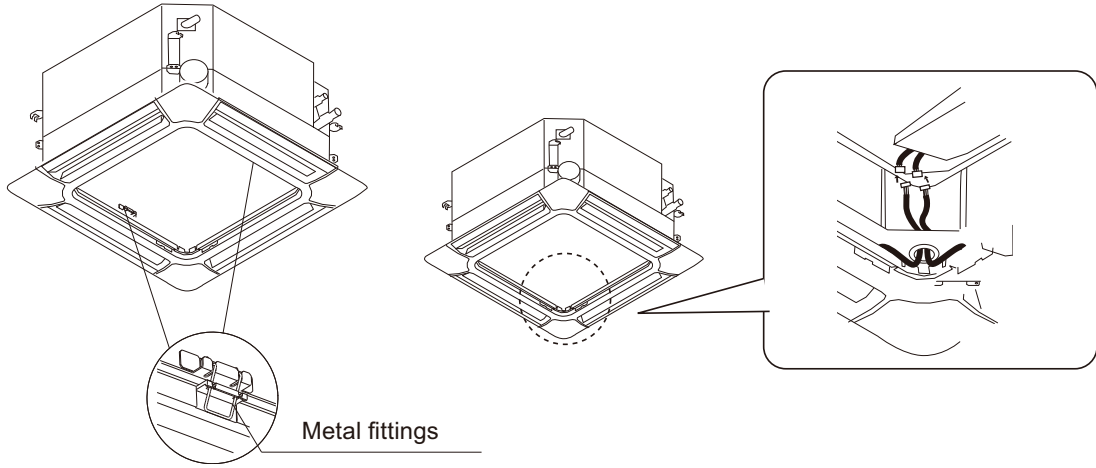

■ Installation example

- Standard

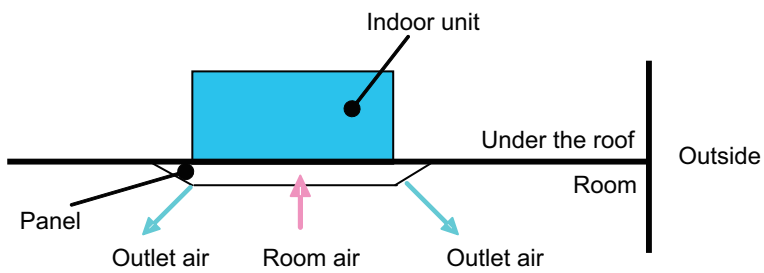

- Case 1: Intake by fan of indoor unit

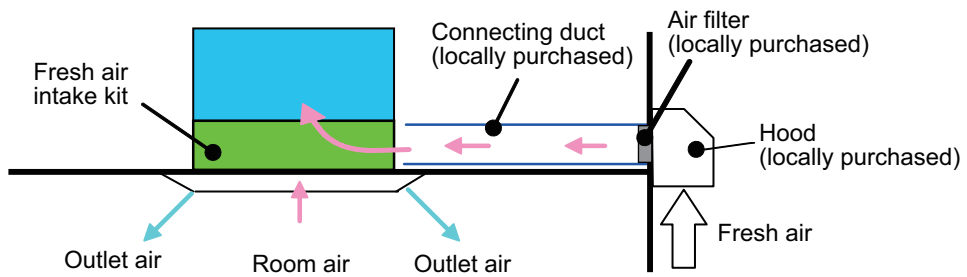

- Case 2: Intake by duct fan

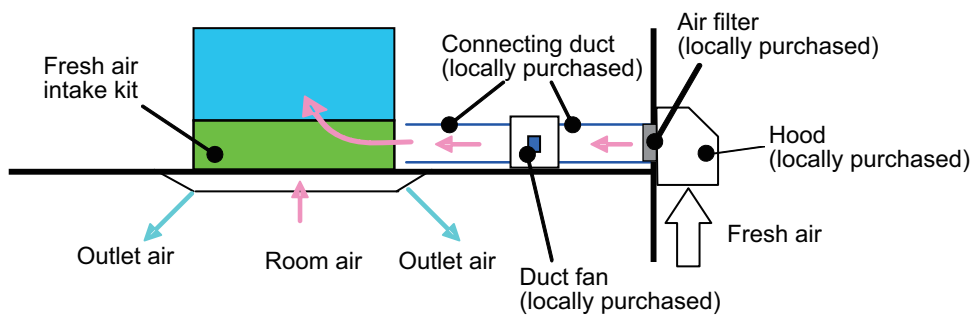

10-4. Fresh air intake kit for compact cassette type (UTZ-VXAA)

■ Specifications

Model name			UTZ-VXAA
Fresh air intake	Max. fresh air intake volume	% (For High)	10
Connection duct type		mm	Ø 100
		Pcs	1
Dimensions (H × W × D)		Net	120 × 570 × 570
		Gross	165 × 585 × 585
Weight		Net	3.5
		Gross	5.5

■ Dimensions

Unit: mm

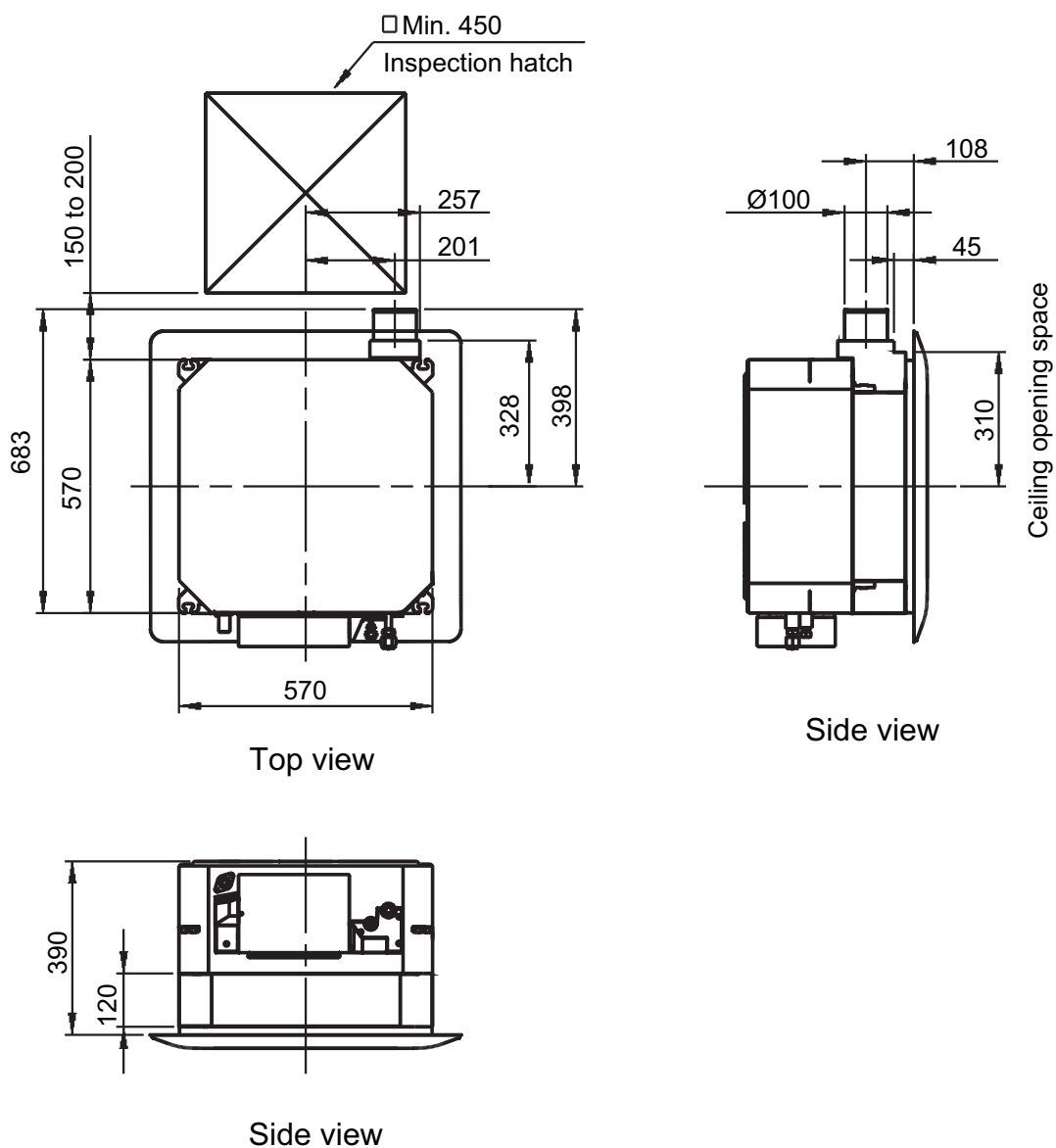

NOTE: When installing this kit, inspection hatch is necessary. (It is necessary when servicing.)

Airflow

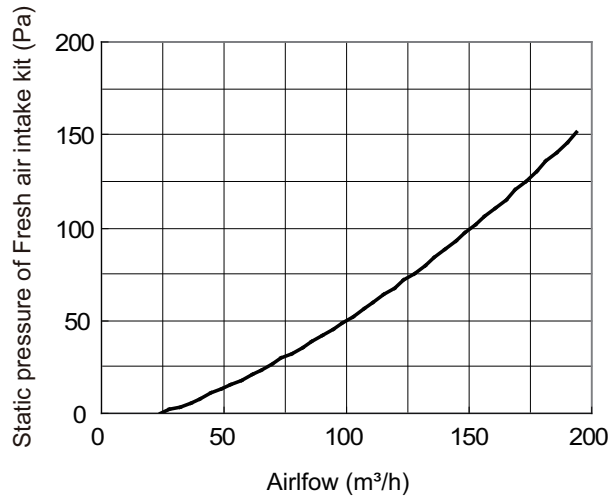

Unit: mm

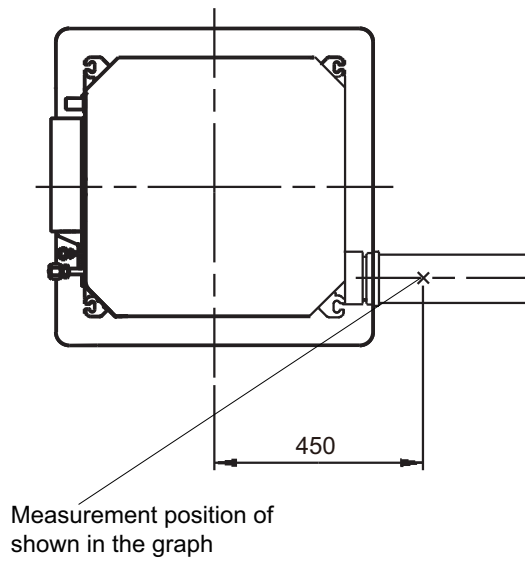

SYSTEM DESIGN

SYSTEM DESIGN

■ Fresh air control output

- You can control duct fan by synchronization with fan operation of indoor unit.
- Wire for fresh air control output is supplied with Fresh air intake kit.

• Connection diagram

For Relay

Output voltage: DC 12 V

Permissible current: 15 mA

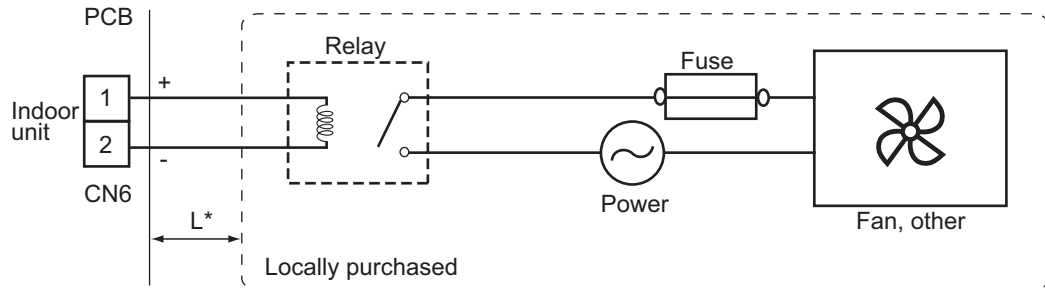

L*: Make the distance from the PCB to the Relay unit within 10 m.



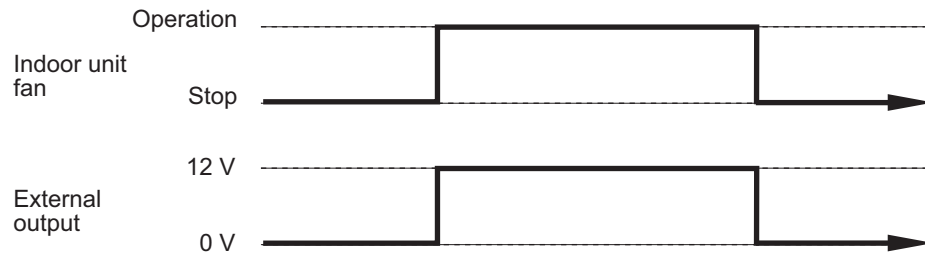







• Operation status

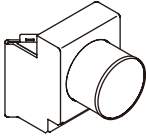

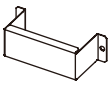
• Wire (External output 1)

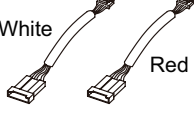

■ Accessories

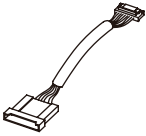
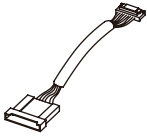
Part name	Exterior	Q'ty	Part name	Exterior	Q'ty
Installation manual		1	Wire (External output 1)		1
Chamber		1	Wire (External output 2)		1
Wire cover		1	Wire (External output 3)		1
Screw		4	Bolt		4
Extension wire for louver		1 set	Cable tie		1
Extension wire for receiver kit (For 9-pin receiver wire)		1	Extension wire for receiver kit (For 7-pin receiver wire)		1

■ Installation precautions

- **About Fresh air intake kit**
 - The Fresh air intake kit can be installed onto cassette type air conditioners.
 - The volume of ventilated air provided by the Fresh air intake kit may be unable to fulfill ventilation regulations in all countries. On such occasions we ask that this kit be used along with Energy recovery ventilators.
 - When intaking outside air, ensure correct air conditioning design as based on air conditioning load calculations. As outside air is not being processing an increase in outside air load can affect air conditioning.
- **Installation location**
 - Area that generated substances that adversely affect the equipment, such as sulfuric gas, chlorine gas, acid, or alkali it will cause the copper pipes and brazed joints to corrode, which can cause refrigerant leakage.
 - Area with high salt content, such as at the seaside. It will deteriorate metal parts, causing the parts to fall or the unit to leak water.
 - Be certain to use electric dampers and shutters to avoid infiltration of cold air, wind and fog during shutdown in areas with cold climate, strong winds, or where fogs are common.
 - Ensure the product is installed a distance of at least three times the duct diameter away from exterior wall air inlets, or air exhausts for the prevention of short circuits.
- **Temperature conditions**
 - Condensation may form on the product when outside air temperature is low and the temperature and humidity surrounding the product are high. Do not intake the air of below 0 °C into the Fresh air intake kit.
 - Do not take fresh air at a temperature that exceeds the upper limit of the operation temperature range of the outdoor unit.
- **About duct fan**
 - When installing the duct fan, connect the drive relay (locally purchased) and operate with the indoor unit.
 - Ensure the intake air volume is below 10 % of the product's air volume High. When the intake air volume becomes too large there the operating noise may increase and room temperature detection may be affected.
- **About the duct connection**
 - Purchase a duct with internal diameter that fits the external diameter of the duct flange.
 - Note that regulations of some countries may require the use of a nonflammable duct.
 - If the duct penetrates a fire-retarding division or other fire-proofing measures, the installation of fire dampers, or a construction that does not adversely affect fire control measure is a regulatory requirement of some countries.
 - When using metallic ducts, ensure metals (i.e., metal lath, wire lath, stainless sheeting) are electrically insulated. (A short occurring by electrical connection can cause fire.)
 - Ensure the thermally insulate connected ducts to prevent condensation.
 - Make certain that netting or other measures are installed in parts exposed to the outside air to prevent infiltration of small animals such as birds and insects.
 - Be certain to install external air filters to parts exposed to the outside air for heat exchanger protection of indoor equipment.
 - Avoid the infiltration of rain water by installing outside ducts with an incline of at least 1/30, and fitting hoods on openings.

■ Installation

● Mounting of indoor unit

- For mounting, refer to the installation manual provided with indoor unit.
- When installing this product to existing indoor units, adjust the installation height of the indoor units to height 260 to 265 mm as shown below.

Unit: mm

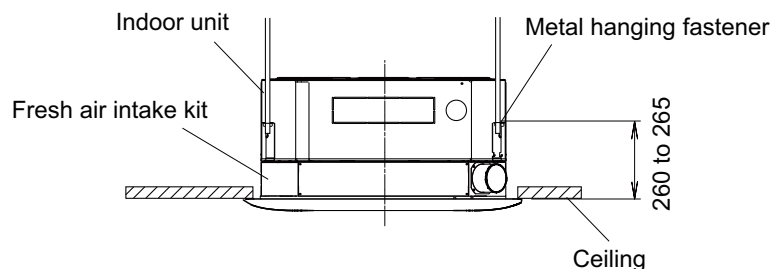

● Installation of Fresh air intake kit

⚠ CAUTION

Installing the Fresh air intake kit with wrong direction is a cause of water leakage.

1. Attach the Fresh air intake kit to the main body using the bolts provided as shown below.

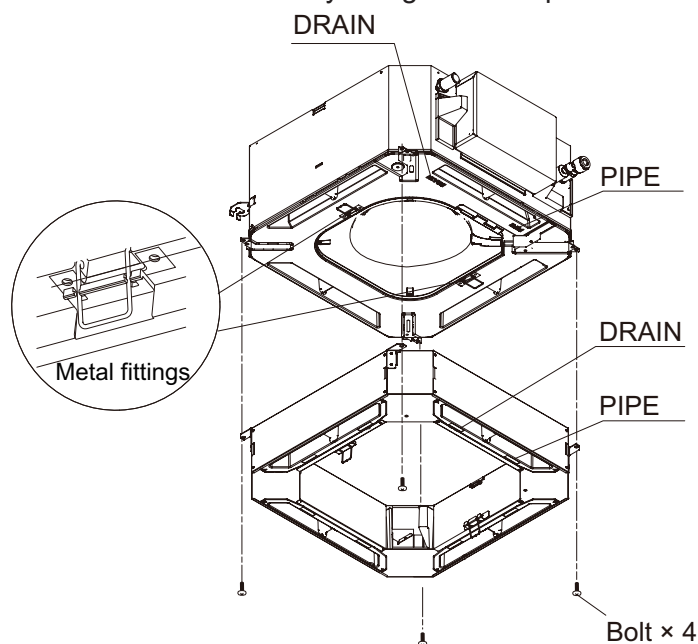

2. Install the chamber.
Fit the four-sided holes of the chamber together with the hook fittings of the Fresh air intake kit (in two places), and secure the attached chamber in place with screws provided.

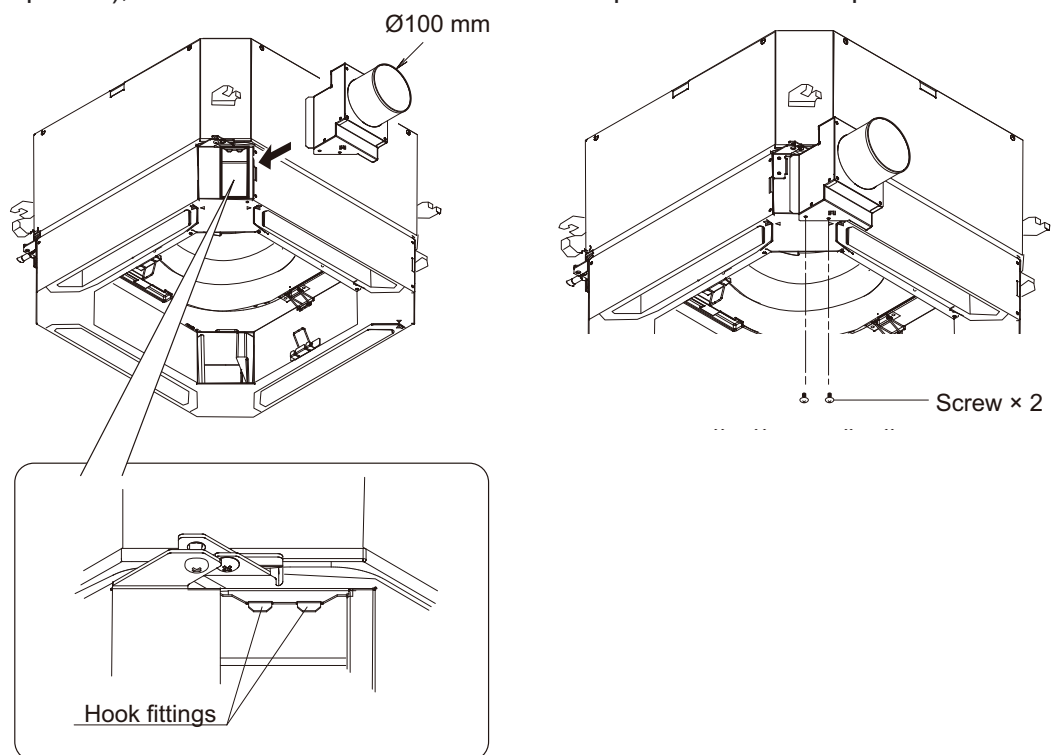

- When using the Insulation kit for high humidity (UTZ-KXGC), first cut off and remove the heat insulation as shown in the figure.
- Install the Insulation kit for high humidity according to the installation instruction sheet provided.

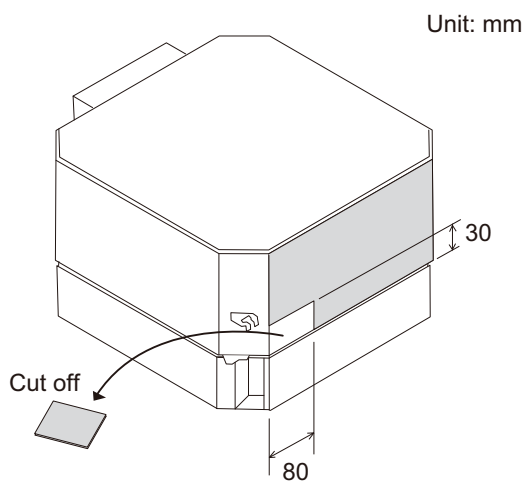

3. Install the duct.

Fasten the connecting parts of the ducts with band, and wrap with vinyl tape to ensure no air leaks. (Carry out the work to ensure no air leakage at a pressure of 200 Pa.)

NOTE: Do not construct the duct in the manner of below.

- Extreme bends
- Highly repetitive bends
- Making the connecting duct diameters smaller

Completion figure

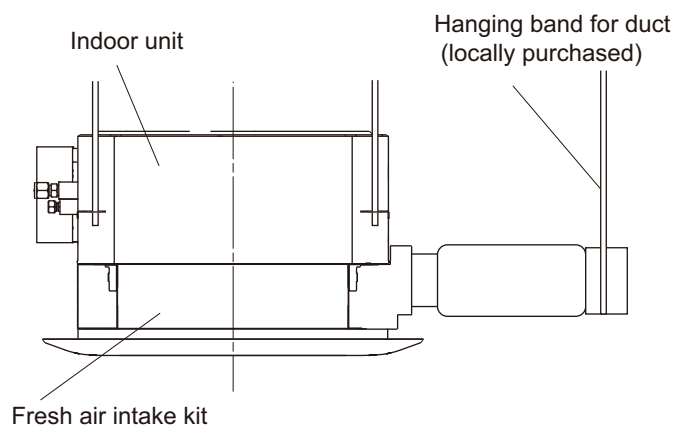
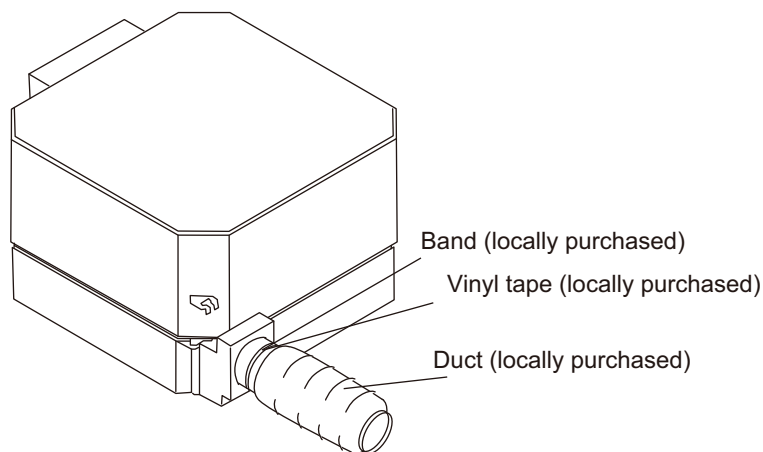







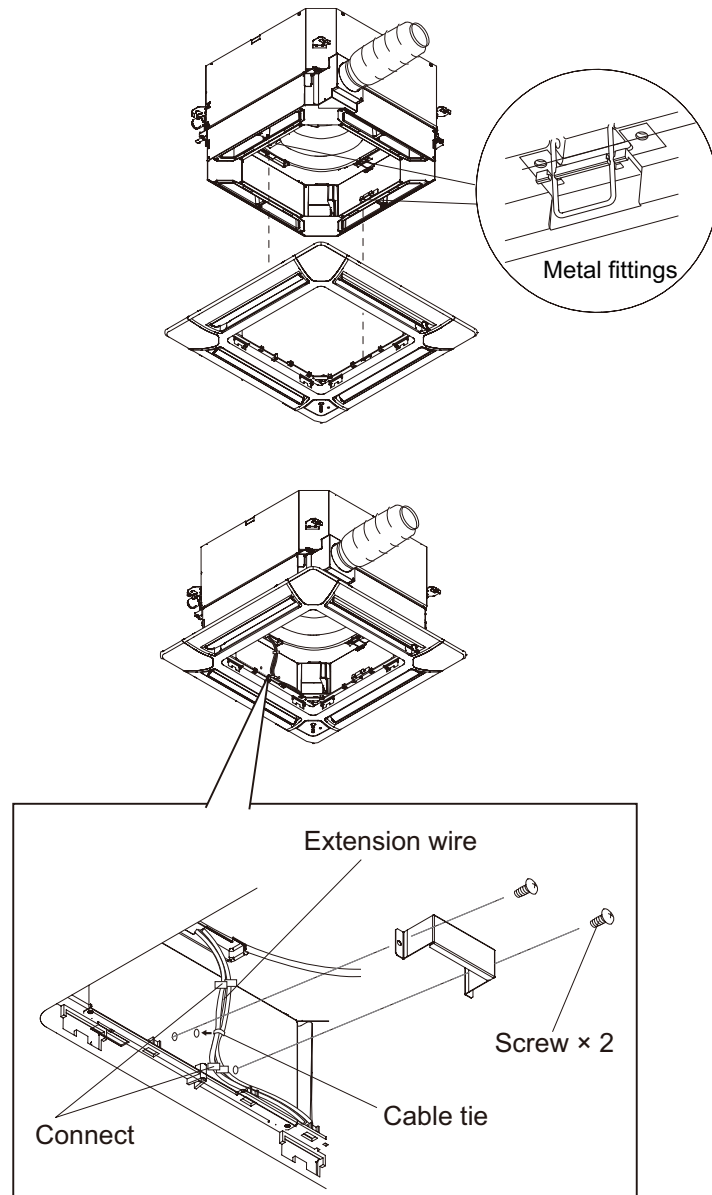

NOTE: When wiring of the duct fan is required, refer to "[Fresh air control output](#)" on page 315.

● Installation of Cassette grille

1. Connect extension wire for use with louvers, or extension wire for optical receiver after provisional attaching of the decoration panel.
2. Tie the wires together with the fasteners provided and insert into the hole of the Fresh air intake kit.
3. Install the wire-cover provided on the Fresh air intake kit.
4. Install decoration panel according to the installation instruction sheet provided.

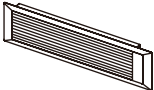

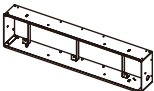
■ Accessories

Part name	Exterior	Q'ty	Part name	Exterior	Q'ty
Installation manual		1	Screw A		16
Operating manual		1	Screw B		6
Grille		1	Cable clip		2
Bracket frame		1	Cable tie		3
Bushing		1			

■ Installation precautions

- Select the installation location that meets the following requirement and that is approved by the customer.
 - Cool and warm air should reach the entire room.

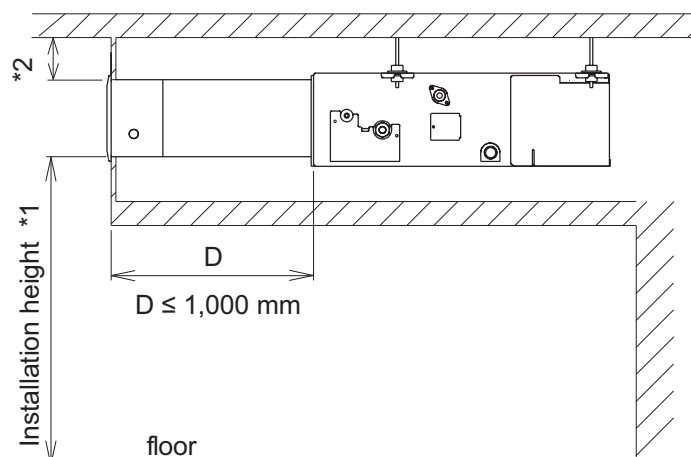

- NOTE:**
- *1: For air velocity and air temperature distribution during heating, refer to "[Air velocity and temperature distributions](#)" on page 30.
 - *2: If the distance from the ceiling is not adequate, it may cause mildew stains on the wall or ceiling. Install at least 150 mm away from any surface.

- Do not install the unit in the following areas.
 - The upper part of the vicinity of room entrance
It may cause condensation on the outlet port.
 - Near a wall surface
It may cause condensation on the wall during cooling.
 - Area filled with mineral oil or containing a large amount of splashed oil or steam, such as kitchen.
 - The place where it will be exposed to direct sunlight.
It may cause change in color.
- When the installation area is exposed direct sunlight, take measure to block the light such as covering the grille surface with a sheet. Otherwise, it may cause a change in color.
- Use an appropriate grille that is compatible with the indoor unit. If not used with the correct combination, it may cause condensation.
- Perform heat insulation and field setting according to the Installation manual of indoor unit. Not installing as per the instructions may cause condensation.

Part 4. OPTIONAL PARTS

1. Branch pipes

1-1. Model: UTP-SX272A

Unit: mm

Port diameters			
Liquid pipe	Q'ty	Gas pipe	Q'ty
	1		1

Dimensions	
Liquid pipe	Gas pipe

Heat insulation cover			
Liquid pipe	Q'ty	Gas pipe	Q'ty
	1		1

OPTIONAL PARTS

OPTIONAL PARTS

1-2. Model: UTP-SX372A

Unit: mm

Port diameters			
Liquid pipe	Q'ty	Gas pipe	Q'ty
<p>Ø12.70</p> <p>Ø9.52</p>	1	<p>Ø22.22</p> <p>Ø25.40</p> <p>Ø15.88</p>	1

Dimensions	
Liquid pipe	Gas pipe
<p>77</p> <p>142</p> <p>196</p> <p>252</p> <p>357</p>	<p>97</p> <p>144</p> <p>214</p> <p>284</p>

Heat insulation cover			
Liquid pipe	Q'ty	Gas pipe	Q'ty
	1		1

Others			
Adapter	Q'ty	Cable tie	Q'ty
<p>Ø6.35</p> <p>Ø9.52</p>	3		1

OPTIONAL PARTS

OPTIONAL PARTS

1-3. Model: UTP-SX236A

Unit: mm

Port diameters			
Liquid pipe	Q'ty	Gas pipe	Q'ty
	1		1

Dimensions	
Liquid pipe	Gas pipe

Heat insulation cover			
Liquid pipe	Q'ty	Gas pipe	Q'ty
	1		1

OPTIONAL PARTS

OPTIONAL PARTS

1-4. Model: UTP-SX254A

Unit: mm

Port diameters			
Liquid pipe	Q'ty	Gas pipe	Q'ty
	1		1

Dimensions	
Liquid pipe	Gas pipe

Heat insulation cover			
Liquid pipe	Q'ty	Gas pipe	Q'ty
	1		1

Others			
Adapter	Q'ty		
	2		

OPTIONAL PARTS

OPTIONAL PARTS

2. Controllers







2-1. Lineup

Indoor unit type	Type		
	Wired remote controller		Wireless remote controller
	UTY-RVNGM	UTY-RNNGM	AR-RAH1E AR-RAH2E
Compact cassette	○	○	●
Cassette	○	●	—
Slim duct	○	●	—
Duct	○	●	—
Floor/Ceiling	○	○	●
Ceiling	○	○	●

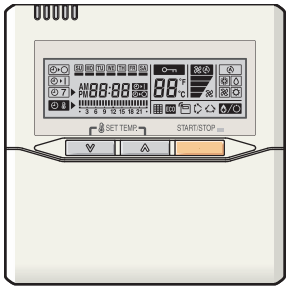
Indoor unit type	Type		
	IR receiver kit with Wireless remote controller		Simple remote controller
	UTY-LRHGA2	UTY-LRHGM	UTY-RSNGM
Compact cassette	—	—	○
Cassette	○	—	○
Slim duct	—	○	○
Duct	—	○	○
Floor/Ceiling	—	—	○
Ceiling	—	—	○

●: Accessory, ○: Optional, —: Not applicable

2-2. Parts

Wired remote controller		Wireless remote controller	
 <p>UTY-RVNGM</p>	 <p>UTY-RNNGM</p>	 <p>AR-RAH1E</p>	 <p>AR-RAH2E</p>
IR receiver kit with Wireless remote controller		Simple remote controller	
 <p>UTY-LRHGA2</p>	 <p>UTY-LRHGM</p>	 <p>UTY-RSNGM</p>	

OPTIONAL PARTS

OPTIONAL PARTS

3. Cassette grille

3-1. Lineup

Type	Model	Indoor units	
		Cassette	Compact cassette
Cassette grille	UTG-UGGA-W	○	—
	UTG-UFGD-W	—	○

○: Optional, —: Not applicable

3-2. Parts

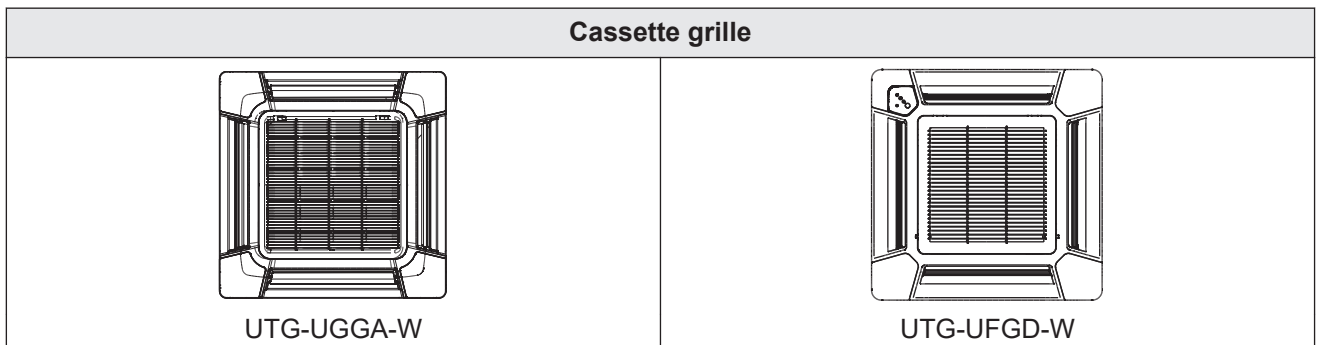







4. Others

4-1. Lineup

Type	Model	Indoor unit						Outdoor unit
		Compact cassette	Cassette	Slim duct	Duct	Floor/Ceiling	Ceiling	
Air outlet shutter plate	UTR-YDZB	○	—	—	—	—	—	—
	UTR-YDZK	—	○	—	—	—	—	—
Insulation kit for high humidity	UTZ-KXGC	○	—	—	—	—	—	—
	UTZ-KXRA	—	○	—	—	—	—	—
Fresh air intake kit	UTZ-VXAA	○	—	—	—	—	—	—
	UTZ-VXRA	—	○	—	—	—	—	—
Panel Spacer	UTG-BKXA-W	—	○	—	—	—	—	—
Wide Panel	UTG-AKXA-W	—	○	—	—	—	—	—
Square flange	UTD-SF045T	—	—	—	○	—	—	—
Round flange	UTD-RF204	—	—	—	○	—	○	—
Long-life filter	UTD-LF25NA	—	—	—	○	—	—	—
Remote sensor unit	UTY-XSZX	—	—	○	○	—	—	—
Auto louver grille kit	UTD-GXTB-W	—	—	○	—	—	—	—
Drain pump unit	UTZ-PX1NBA	—	—	—	○	—	—	—
	UTR-DPB24T	—	—	—	—	—	○	—
External control set	UTD-ECS5A	—	—	○	○	—	—	—
External connect kit	UTY-XWZX	○	○	—	—	○	○	—
	UTY-XWZXZ3	—	—	—	—	—	—	○

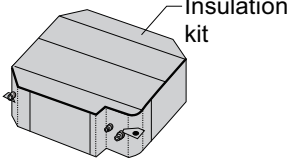
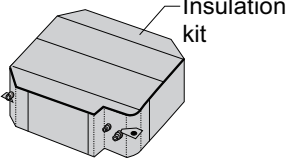
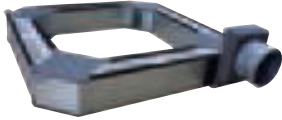

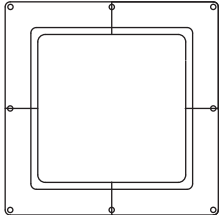
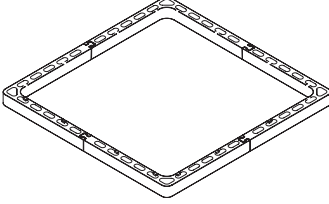



○: Optional, —: Not applicable

4-2. Parts

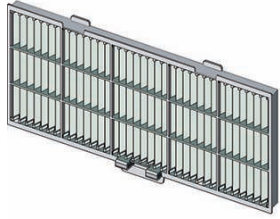
<p>Air outlet shutter plate Model: UTR-YDZB</p>	<p>Air outlet shutter plate Model: UTR-YDZK</p>
 <p>For compact cassette type</p>	 <p>For cassette type</p>
<p>Insulation kit for high humidity Model: UTZ-KXGC</p>	<p>Insulation kit for high humidity Model: UTZ-KXRA</p>
 <p>For compact cassette type</p>	 <p>For cassette type</p>
<p>Fresh air intake kit Model: UTZ-VXAA</p>	<p>Fresh air intake kit Model: UTZ-VXRA</p>
 <p>For compact cassette type</p>	 <p>For cassette type</p>
<p>Wide panel Model: UTG-AKXA-W</p>	<p>Panel spacer Model: UTG-BKXA-W</p>
 <p>For cassette type</p>	 <p>For cassette type</p>
<p>Square flange Model: UTD-SF045T</p>	<p>Round flange Model: UTD-RF204</p>
 <p>For duct type</p>	 <p>For duct type and ceiling type</p>

OPTIONAL PARTS

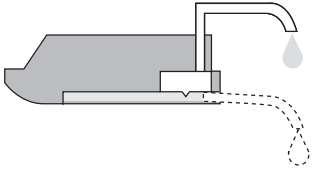
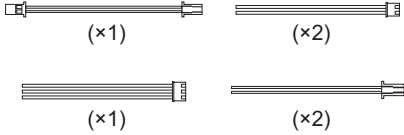
OPTIONAL PARTS

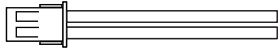
<p>Long-life filter Model: UTD-LF25NA</p>	<p>Auto louver grille kit Model: UTD-GXTB-W</p>
 <p>For duct type</p>	 <p>For slim duct type</p>
<p>Remote sensor unit Model: UTY-XSZX</p>	<p>Drain pump unit Model: UTZ-PX1NBA</p>
 <p>For slim duct type and duct type</p>	 <p>For duct type</p>
<p>Drain pump unit Model: UTR-DPB24T</p>	<p>External control set Model: UTD-ECS5A</p>
 <p>For ceiling type</p>	 <p>For slim duct type and duct type</p>
<p>External connect kit Model: UTY-XWZX</p>	<p>External connect kit Model: UTY-XWZXZ3</p>
 <p>For compact cassette type, cassette type, floor/ceiling type, and ceiling type</p>	 <p>For outdoor unit</p>

OPTIONAL PARTS

OPTIONAL PARTS