

O'Pro Central Domestic



ELECTRIC WATER HEATER

Models 200 to 300

(Floor-standing)

Models 150 to 200

(Vertical and horizontal wall-mounted)



Comfort

- Large tank capacity for more hot water



Durability

- Extended tank life thanks to O'Pro exclusive anti-corrosive system, which permanently combats rust
- Magnesium anode to bolster tank protection
- Diamond-quality glass lining
- Pressure relief valve
- Dielectric union
- Specific lip gasket to prevent corrosion around the flange



Installation

- Range of sizes to meet all installation requirements
- Vertical and horizontal wall-mounted and floor-standing models available
- Easy installation using deeper handles on both sides

Safe operation:

- IP 24 - full compliance with European standards for electrical safety and user protection



Energy savings

- High-efficiency water inlet
- CFC-free high-density insulation to increase energy savings



User-friendly

- Heating light indicator (Wall-mounted model)



- 1 **DIAMOND-QUALITY GLASS LINING** for extended life and increased reliability
- 2 Optimised stainless steel
- 3 **MAGNESIUM ANODE** for protection against corrosion
- 4 Sheathed immersion heating element
- 5 Inlet diffuser
- 6 High-density, 0% CFC polyurethane foam

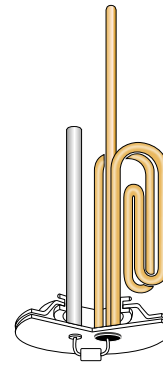
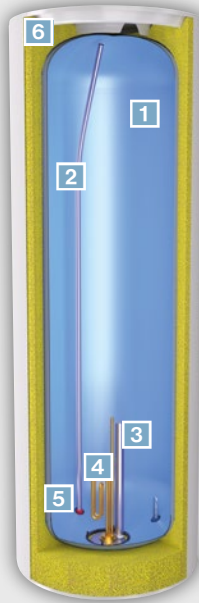

O'Pro
TECHNOLOGY

Exclusive anti-corrosive system

O'Pro technology uses an ohmic resistor to balance out the electric potential of both the tank and the heating element. This prolongs the life of the magnesium anode as well as bolstering protection against corrosion.

Video:



Technical specifications

Model	Output (W)	Voltage (V)	Energy consumption (kWh/ 24 h at 65°C)	Heat-up time at 60°C (Δt=50°C)	Hot water capacity at 40°C (L)	ErP energy Class	Profile
O'Pro Central Domestic Vertical wall-mounted							
150	2200	220-240	1.65	4h14	246	A B C	M
200	2200	220-240	1.94	5h44	374	A B C	L
O'Pro Central Domestic Horizontal wall-mounted							
150	2200	220-240	1.51	4h07	245	A B C	L
200	2200	220-240	1.81	5h33	301	A B C	L
O'Pro Central Domestic Floor-standing							
200	3000	220-240	1.82	5h06	334	A B C	L
300	3000	220-240	2.41	5h53	468	A B C	L

Installation dimensions (mm)

Model	Dimensions (mm)						Net weight (kg)
	Ø	A	B	C	H		
O'Pro Central Domestic Vertical wall-mounted							
150	513	1050	800	530	1155	35	
200	513	1050	800	530	1475	43	
O'Pro Central Domestic Horizontal wall-mounted							
150	520	-	800	610	1150	37	
200	520	-	1050	610	1470	45	
O'Pro Central Domestic Floor-standing							
200	575	-	-	590	1270	47	
300	575	-	-	590	1765	60	

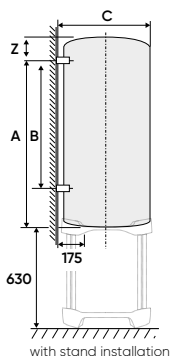

VERTICAL WALL-MOUNTED

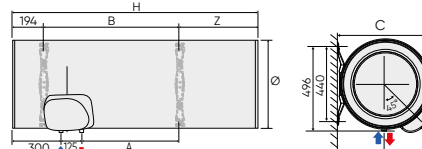
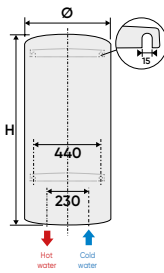

HORIZONTAL WALL-MOUNTED

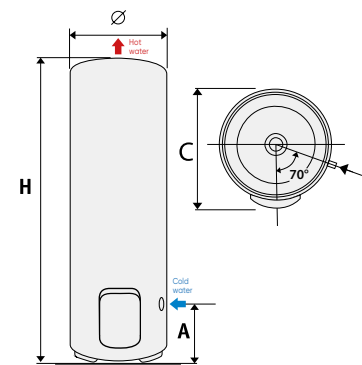

FLOOR-STANDING