

SBK ST PLUS

SCAMBIATORE A PIASTRE ISPEZIONABILE

→ Scambiatore di calore a piastre ispezionabili



Equipaggiamento

- Scambiatore a piastre interamente costruito in metallo
- Piastre in acciaio inox
- Pressione di utilizzo 10 bar
- Pressione di prova 14 bar



SBK ST

Codice	Modello
102267	SBK 1 ST Plus
102268	SBK 2 ST Plus
102269	SBK 3 ST Plus
102270	SBK 4 ST Plus
102089	SBK 5 ST Plus
102271	SBK 6 ST Plus
102272	SBK 7 ST Plus
102100	SBK 8 ST Plus
102249	SBK 9 ST Plus
102104	SBK 10 ST Plus
102101	SBK 11 ST Plus
102103	SBK 12 ST Plus
102111	SBK 13 ST Plus
102114	SBK 14 ST Plus
102122	SBK 15 ST Plus

- Manutenzione di tutti i componenti (piastre e guarnizioni)
- Alta efficienza termica
- Adatto ad applicazioni che richiedono poco spazio senza costose manutenzioni

DIMENSIONI SBK ST PLUS (in mm)

Modello	A	B	L	Attacchi	Peso
	mm	mm	mm	"	Kg
SBK 1 ST Plus	754	200	150	1"1/4	48
SBK 2 ST Plus	754	200	150	1"1/4	51,6
SBK 3 ST Plus	870	320	300	2"	110,9
SBK 4 ST Plus	870	320	300	2"	115,9
SBK 5 ST Plus	870	320	300	2"	121,16
SBK 6 ST Plus	870	320	300	2"	125,6
SBK 7 ST Plus	870	320	500	2"	138,8
SBK 8 ST Plus	987	384	500	DN 65	200,8
SBK 9 ST Plus	987	384	700	DN 65	227,8
SBK 10 ST Plus	1039	465	700	DN100	317,2
SBK 11 ST Plus	1039	465	700	DN100	336,8
SBK 12 ST Plus	1039	465	1000	DN100	349
SBK 13 ST Plus	1039	465	1000	DN100	358,8
SBK 14 ST Plus	1039	465	1000	DN100	371,1
SBK 15 ST Plus	1039	465	1000	DN100	383,4

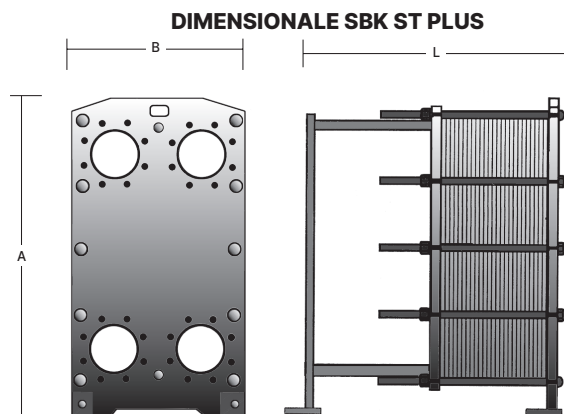

SCHEMA DI COLLEGAMENTO

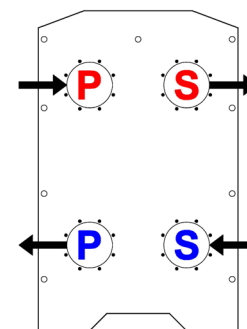

TABELLA DI SELEZIONE

Modello	Potenza	Temp. I	Temp. II	Portata I	Portata II	ΔP I	ΔP II	Superficie
	kW	°C	°C	m³/h	m³/h	KPa	KPa	m²
SBK 1 ST Plus	40	80/60	70/55	1.76	2.34	11	18	1.26
SBK 2 ST Plus	60	80/60	70/55	2.63	3.47	11	19	1.93
SBK 3 ST Plus	100	80/60	70/55	4.4	5.8	12.2	16.4	2.4
SBK 4 ST Plus	150	80/60	70/55	6.7	8.8	13.4	19.6	3.3
SBK 5 ST Plus	180	80/60	70/55	8	10.5	11.7	17.8	4.2
SBK 6 ST Plus	220	80/60	70/55	9.8	12.8	11.8	18.1	5.1
SBK 7 ST Plus	350	80/60	70/55	15.5	20.4	12.2	19.7	8.1
SBK 8 ST Plus	400	80/60	70/55	17.6	23.4	11	18	9.8
SBK 9 ST Plus	600	80/60	70/55	26.6	35	11	19	15.59
SBK 10 ST Plus	800	80/60	70/55	35.5	46.7	12.6	19.5	17.04
SBK 11 ST Plus	1000	80/60	70/55	44.3	58.4	12.6	19.5	20.88
SBK 12 ST Plus	1100	80/60	70/55	48.8	64.2	12.4	19.4	23.28
SBK 13 ST Plus	1200	80/60	70/55	53.2	70.1	12.7	19.8	25.2
SBK 14 ST Plus	1300	80/60	70/55	57.6	75.9	12.6	19.7	27.6
SBK 15 ST Plus	1400	80/60	70/55	62.1	81.7	12.7	19.9	30