

# Steatite Central Domestic



## ELECTRIC WATER HEATER

### MODELS 150 TO 200

(Vertical wall-mounted)

### MODELS 200 TO 300

(Floor-standing)



### Comfort

- Greater comfort using one large-capacity central storage tank



### Durability

- Steatite technology: ceramic dry heating element protected by a sleeve for limited scaling and easy maintenance
- Diamond-quality glass lining
- Magnesium anode to bolster tank protection
- Pressure relief valve
- Dielectric union
- Specific lip gasket to prevent corrosion around the flange



### Installation

- Easy installation using deeper handles on both sides
- Vertical and floor standing model available

#### Safe operation:

- IP 24 - full compliance with European standards for electrical safety and user protection



### Energy savings

- High-efficiency water inlet
- CFC-free high-density insulation to increase energy savings



### User-friendly

- Heating light indicator (Wall-mounted model)



- 1 DIAMOND-QUALITY GLASS LINING** for extended life and increased reliability
- 2** Optimised stainless steel outlet pipe
- 3** High-density, 0% CFC polyurethane foam
- 4** **MAGNESIUM ANODE** for protection against corrosion
- 5** Optimised inlet diffuser
- 6 ELECTRONIC REGULATION** for temperature control accuracy

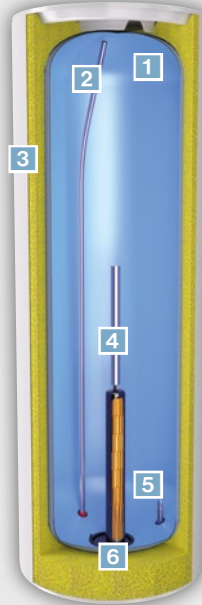

Video:



**Steatite**  
TECHNOLOGY

### Steatite dry heating element

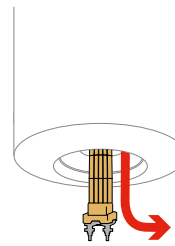

Adapted to aggressive, mineralised and desalinated water. Its protective enamel-coated steel sleeve facilitates maintenance, and there is never any need to drain the tank to replace it.

## Technical specifications

Model	Output (W)	Voltage (V)	QPR	V40 L	Heat-up time from 15°C to 65°C	ErP energy class	Profile
<b>Steatite Central Domestic Vertical wall-mounted</b>							
150	1800	220-240	1.45	275	5h12	A F C	M
200	2200	220-240	1.81	373	6h11	A F C	L
<b>Steatite Central Domestic Floor-standing</b>							
200	2200	220-240	1.85	-	5h22	A F C	L
300	3000	220-240	2.5	-	6h08	A F C	L

## Installation dimensions (mm)

Model	Diameter (Ø)	Dimensions (mm)				Net weight (kg)
		H	A	B	C	
<b>Steatite Central Domestic Vertical wall-mounted</b>						
150	513	1155	1050	800	530	35
200	513	1475	1050	800	530	44
<b>Steatite Central Domestic Floor-standing</b>						
200	575	1270	280	-	645	47
300	575	1765	280	-	645	60

NF CE ENEC IP 24

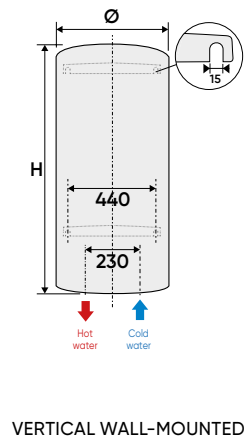
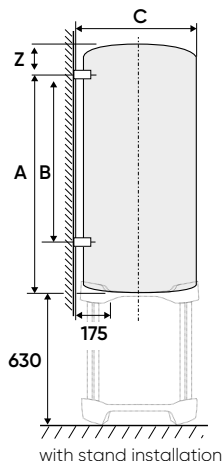

VERTICAL WALL-MOUNTED

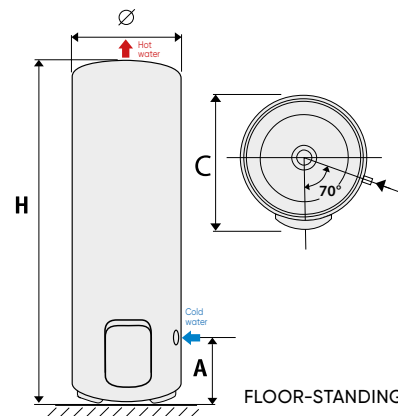

FLOOR-STANDING