

# Alfea Extensa Duo R32

## Schemi d'installazione

### A - Alfea Extensa Duo A.I. R32: 1 circuito di riscaldamento

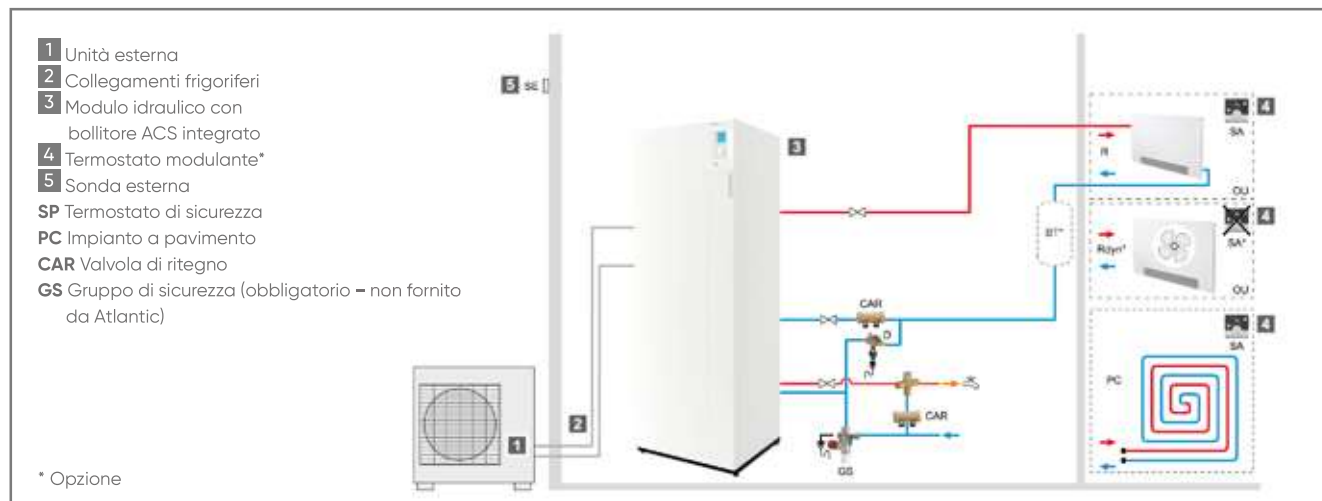

### B - Alfea Extensa Duo A.I. R32: 2 circuiti di riscaldamento

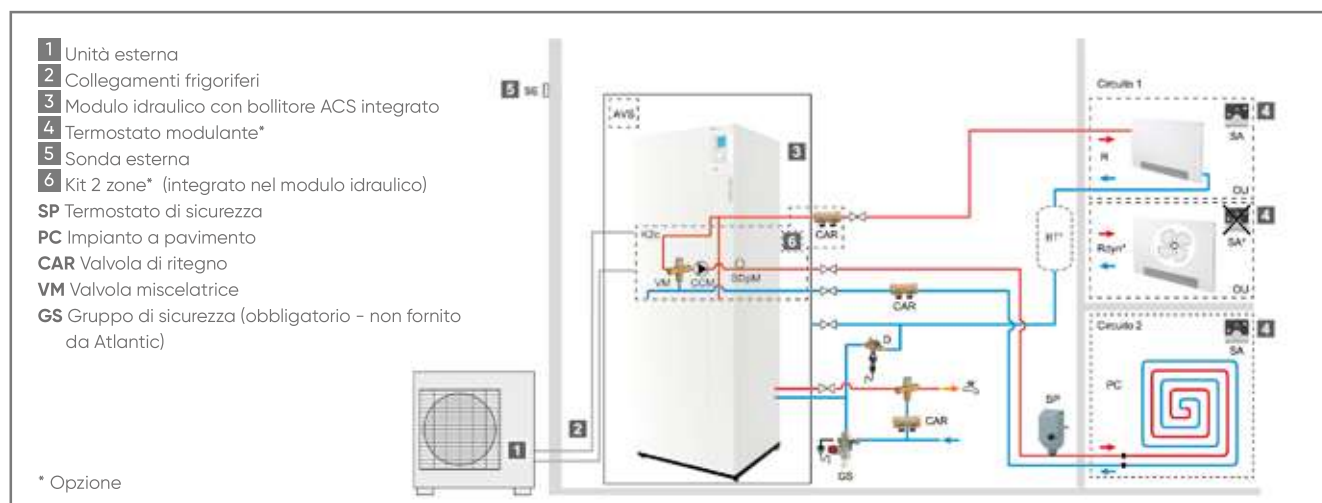

\* Schemi indicativi, consultare i manuali istruzioni dei kit opzionali e prevedere un accumulo inerziale dimensionato opportunamente, nel caso fosse necessario

# Alfea Extensa Duo R32

Dimensioni (in mm)

## Unità esterna Alfea Extensa Duo A.I. R32 5 e 6

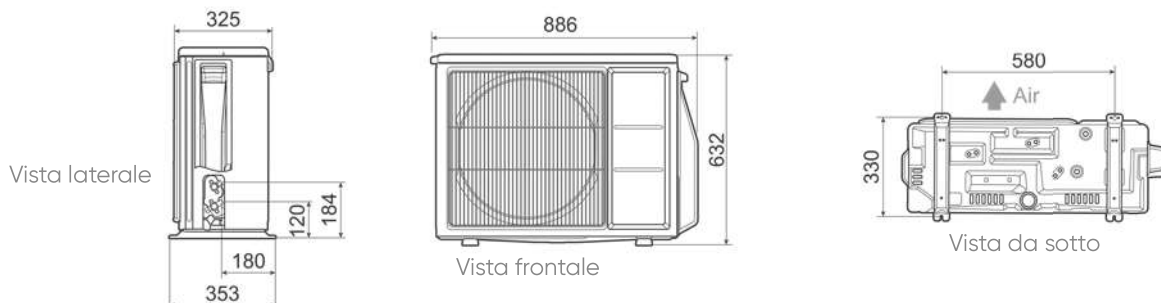

## Unità esterna Alfea Extensa Duo A.I. R32 8

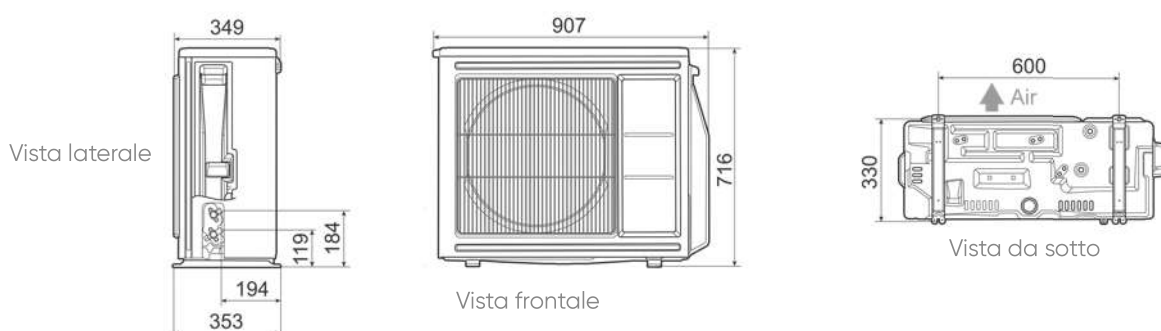

## Unità esterna Alfea Extensa Duo A.I. R32 10

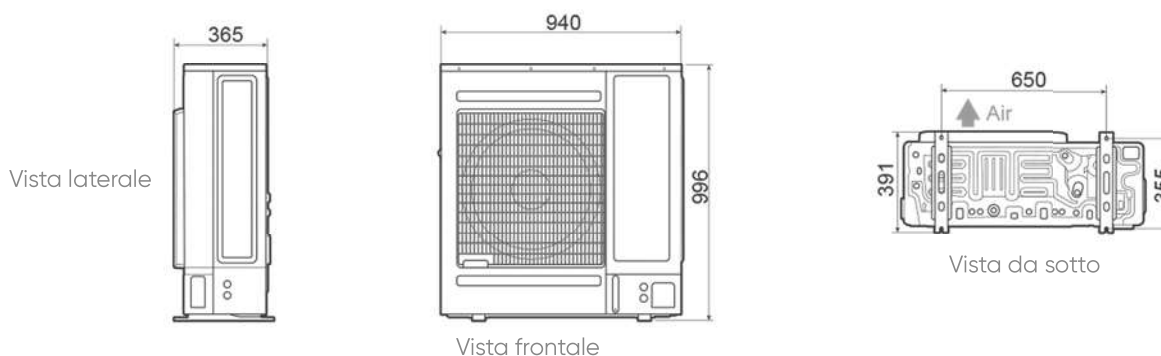

## Unità interna

