

EGO

DESIGNED TO LAST THROUGH PROTECTED TANK AND
A STEADY STREAM OF HOT WATER

VM models 30 to 100 & HM model 80



BENEFITS

- Maximum protection against corrosion thanks to diamond quality enamel tank
- Optimized water inlet diffuser distributes the water gradually providing a greater supply of hot water
- New waterdrop LED heating indicator



+ END-USER FRIENDLY WITH WATERDROP LED HEATING INDICATOR



WATERDROP LED INDICATOR

Easy-to-use:

The newly designed waterdrop led heating indicator allows you to know when your water is heating

EGO

VM models 30 to 100 & HM model 80

+ RELIABLE TANK WITH DIAMOND-QUALITY ENAMEL

- 1** High quality enamel
- 2** High density insulated foam (free of CFC)
- 3** Copper heating element & thermostat sleeve
- 4** Rod thermostat
- 5** Magnesium anode
- 6** Optimized stainless steel outlet pipe
- 7** Optimized Inlet diffuser

MAGNESIUM ANODE:
The magnesium anode is located at the center of the enamelled tank. It helps provide excellent protection against corrosion and balanced water.

+ EASY INSTALLATION

Installation dimensions

Model	Dimensions (mm)							Flange opening (Ø) mm	Net weight (kg)
	A	B	C	D	E	F	G		
Vertical wall-mounted									
30	443	433	261	450	158	300	240	72	11,6
50	607	433	395	450	158	300	240	72	15,2
80	806	433	605	450	158	300	240	72	19,7
100	1008	433	747	450	158	300	240	72	23,5
Horizontal wall-mounted									
80	806	433	395	450	158	300	240	72	19,7

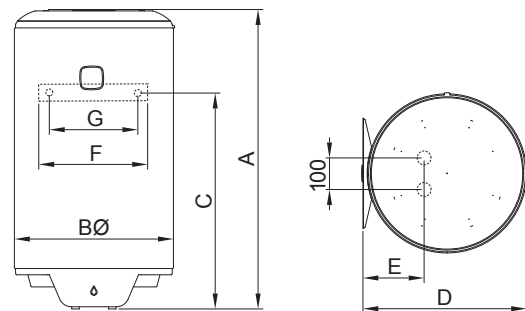

Technical data

Model	Output (W)	Voltage (V)	QPR (kWh/24)	V40 (L)	Heating time	Profile	Erp energy class
Vertical wall-mounted							
30	1200	220-240	0,68	50,6	1h35	S	C
50	1200	220-240	1,01	81	2h39	M	C
80	1200	220-240	1,35	124	3h11	M	C
100	1500	220-240	1,63	174	4h15	L	C
Horizontal wall-mounted							
80	1500	220-240	1,33	114	2H52	M	C