

the **HAMWORTHY**

# BIG BOOK



**BOILERS | WATER HEATERS | CALORIFIERS | EXPANSION VESSELS | HEAT PUMPS | STORAGE TANKS  
PRESSURISATION UNITS | FLUES | CONTROLS | DOSING POTS | AIR & DIRT SEPARATORS**



SCAN  
ME

[hamworthy-heating.com](http://hamworthy-heating.com)

[sales@hamworthy-heating.com](mailto:sales@hamworthy-heating.com) | 01202 662500



**Hamworthy**

# Contents

---

## HEAT PUMPS

---

**04** Tyneham  
290HT

**07** Tyneham  
CO2 and CO2Q

**12** Tyneham

## BOILERS

---

**16** Stratton mk3  
wall hung boiler

**20** Wessex  
ModuMax mk3  
boiler

**24** Upton boiler

**28** Varmax boiler

**30** Purewell Variheat  
mk2 boiler

## WATER HEATERS

---

**32** Dorchester DR-SG  
water heater

**35** Dorchester  
DR-FC Evo  
water heater

**38** Dorchester DR-CC  
Condensing  
water heater

**40** Powerstock  
calorifier

**42** Powerstock  
storage tank

**44** Halstock  
calorifier

**46** Halstock  
storage tanks

## ANCILLARY PRODUCTS

---

**48** Hydraulic system  
separation

**49** Merley sequence  
controller

**50** Horton  
dosing pot

**51** Clenston air and  
dirt separator

**52** Burstock  
expansion vessel

**54** Chesil mk2  
pressurisation unit

**55** Tyneham  
buffer tanks

**57** Flues

## SERVICE AND SUPPORT

---

**58** Expert academy  
training

**59** CIBSE approved  
CPD courses

**60** Service and  
warranty

# *The complete* plant room solution



• Trusted expertise since 1914.

**Hamworthy Heating** is a British commercial heating manufacturer. Our low carbon commercial heating and hot water products are used in buildings across the UK.

Trusted expertise since 1914.



SCAN  
ME

Stay up to date with key topics in commercial heating, hot water, legislation and the journey to net zero on our website.

# Tyneham 290HT

5 models  
15-50 kW output

Using R290 natural refrigerant, the Tyneham 290HT achieves higher flow temperatures, improved efficiencies and low carbon heating.

## Key benefits:

- > Monobloc air source heat pumps
- > Single unit with the refrigeration cycle contained within the outdoor unit
- > Inverter controlled compressor to accurately match the heat demand
- > Ultra-low global warming potential due to the use of R290 natural refrigerant
- > Able to achieve high temperatures up to 75°C
- > Highly efficient coefficient of performance (COP)\*
- > Quiet noise level as low as 64 dB(A)\*\*
- > Suited to larger installations – cascade systems to achieve higher output
- > Combine with Hamworthy's boilers for a hybrid heating system
- > 2 year warranty (extended to a 5-year if commissioned by Hamworthy Heating)
- > Back up and long-term support from our team of experienced UK based engineers



**Able to achieve max flow  
temperatures up to 75°C**

# Tyneham 290HT

## Technical information

	Tyneham model	Units	15kW	18kW	27kW	40kW	50kW
ENERGY	Heat Pump Space Heating [35°C]	ErP rating	A+++	A+++	A++	A++	A++
	Heat Pump Space Heating [35°C]	SCOP	5.02	4.99	4.46	4.09	4.2
	Heat Pump Space Heating [55°C]	ErP rating	A++	A++	A++	A++	A++
	Heat Pump Space Heating [55°C]	SCOP	4.85	4.76	4	3.83	3.91
	Refrigerant		R290	R290	R290	R290	R290
	Refrigerant Charge	(kg)	1.27	1.27	2.1	3.15	3.5
	Global Warming Potential	GWP	3	3	3	3	3
HEATING	Heating (A7/W35)	Capacity (kW)	15.84	18.77	28.6	40.1	50
	Heating (A7/W35)	Power Input (kW)	3.36	4.03	7.6	13.1	16.5
	Heating (A7/W35)	COP*	4.94	4.62	4.54	4.1	4.2
	Max Flow Temperature	Max [°C]	75	75	75	75	75
	Air Temperature Range	Min/Max [°C]	(-20 +40)	(-20 +40)	(-20 +40)	(-20 +40)	(-20 +40)
SOUND	Sound Data Outdoor unit	Power Level dB(A)**	64	64	65	82	83
	Sound Data Outdoor unit	Pressure Level at 1m dB (A)***	47	47	45	64	65
CONNECTIONS & WATER	Pipework Connection Sizes	Heating Flow (inch)	1	1	1 1/4	1 1/2	1 1/2
	Pipework Connection Sizes	Heating Return (inch)	1	1	1 1/4	1 1/2	1 1/2
	Minimum Water Volume	Litres (l)	230	230	225	365	415
ELECTRICS	Electrical Supply	(v)	400	400	400	400	400
	Phase		Three	Three	Three	Three	Three
	Max Running Current	(amp)	15.8	16.5	21	38	45
	Fuse Rating	(amp)	25	25	25	50	63
DIMENSIONS	Width	(mm)	1100	1100	1610	1895	1895
	Depth	(mm)	510	510	710	1110	1110
	Height	(mm)	1447	1447	1270	1980	1980
	Weight	(kg)	174	174	285	535	550

### Minimum installation clearances:

15, 18 & 27kW models

**Front:** 1500mm

**Rear:** 400mm

**Left:** 400mm

**Right:** 500mm

**Top:** 1500mm.

**Bottom:** 50mm

**Side clearance** of 1000mm when used in cascade.

**The outdoor unit** must be raised by at least 50mm from the ground

### Minimum installation clearances:

40 & 50kW models

**Front:** 1500mm

**Rear:** 1500mm

**Left:** 1200mm

**Right:** 1000mm

**Top:** 1500mm.

**Bottom:** 50mm

**Side clearance** of 2200mm when used in cascade.

**The outdoor unit** must be raised by at least 50mm from the ground.

### Accessories and options:

	Included	Optional
Control unit	•	
Flexible hose		•
Anti-vibration rubber feet		•
Exogel antifreeze kit		•

### Terms and conditions apply:

Tyneham 290HT models all represent the output at Air 7°C & Water 35°C.

\* Coefficient of Performance (COP) rated at EN14825 test conditions Water 35°C / Air 7°C.

\*\* The sound levels refer to a fully loaded unit at standard nominal conditions according to EN12102:2022.

\*\*\* Sound pressure value calculated from the sound power level in condition (9) using the standard UNI EN ISO 3744:2010.

# Tyneham 290HT dimensions

## 15 & 18 kW models

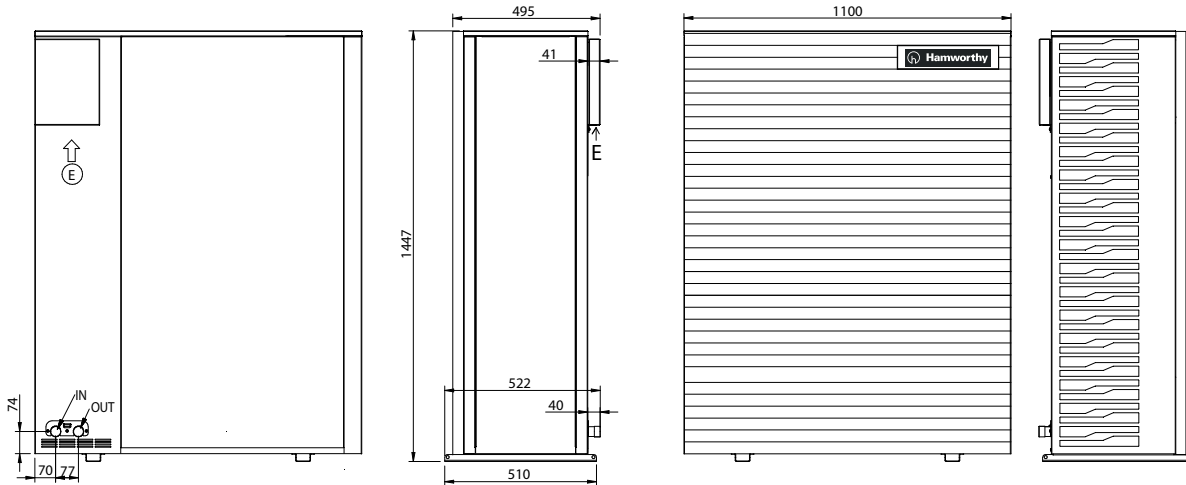

## 27 kW model

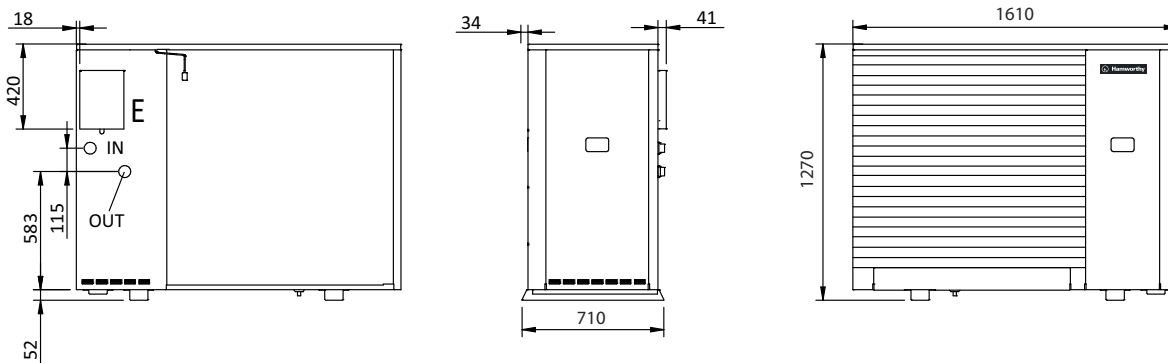

## 40 & 50 kW models

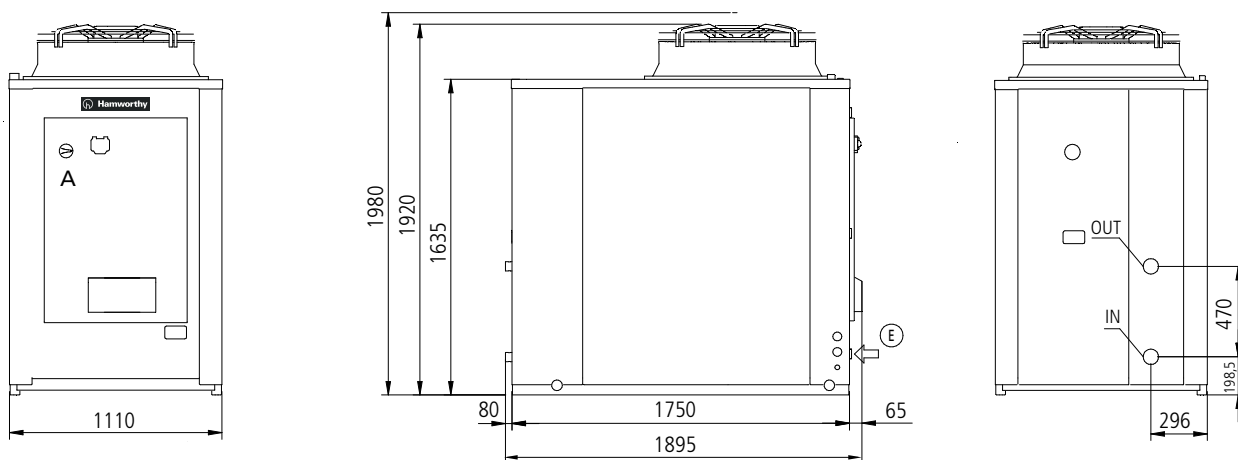

E = electrical

**Note:** All dimensions in mm unless otherwise stated.

# Tyneham CO2 and CO2Q

6 models  
65-130 kW output

Future proof your investment with our range of CO2 natural refrigerant commercial heat pumps. Ideal for when space is limited, this range can be installed flush against a wall or back to back with another unit, and benefits from a low dB(A) rating for minimal background noise.

## Key benefits:

- > Made in the UK
- > Ultra-low GWP due to the use of R744 (CO2) natural refrigerant
- > Highly efficient coefficient of performance (COP)\*
- > Quiet noise levels as standard with low noise models available (CO2Q)
- > Can be installed against a wall or back to back with another unit with no installation clearances required at the rear of the unit
- > Inverter controlled compressor to accurately match the heat demand
- > Single unit with the refrigeration cycle contained within the outdoor unit
- > Suited to larger installations – cascade systems to achieve higher output
- > Combine with Hamworthy's boilers for a hybrid heating system
- > 2-year warranty on parts only
- > Back up and long-term support from our team of experienced UK based engineers



**Ultra low GWP with the  
use of CO2 refrigerant**

# Tyneham CO2 technical specification

	Tyneham model	Units	65kW	95kW	130kW
ENERGY	Heat Pump Space Heating [55°C]	ErP rating	A+++	-	-
	Heat Pump Space Heating [55°C]	COP	3	3	3
	Heat Pump Space Heating [65°C]	ErP rating	A+++	-	-
	Heat Pump Space Heating [65°C]	COP*	3.4	3.4	3.4
	Refrigerant		R744	R744	R744
	Refrigerant Charge	(kg)	4.8	6.5	10
	Global Warming Potential	GWP	1	1	1
HEATING	Heating (A7/W65)	Capacity (kW)	65	95	130
	Heating (A7/W65)	Power Input (kW)	17	25	34
	Heating (A7/W65)	SCOP	3.5	3.5	3.5
	Max Flow Temperature	Max [°C]	70	70	70
	Air Temperature Range	Min/Max [°C]	(-15 no max)	(-15 no max)	(-15 no max)
SOUND	Sound Data Outdoor unit	Power Level dB(A)**	74	75	75
	Sound Data Outdoor unit	Pressure Level at 10m dB (A)***	43	44	44
CONNECTIONS	Pipework Connection Sizes	Heating Flow (mm)	28	35	42
	Pipework Connection Sizes	Heating Return (mm)	28	35	42
ELECTRICS	Electrical Supply	(v)	400	400	400
	Phase		Three	Three	Three
	Max Running Current	(amp)	45.07	67.55	82.19
	Fuse Rating	(amp)	63	80	100
DIMENSIONS	Width	(mm)	2190	3051	3101
	Depth	(mm)	1160	1160	1457
	Height	(mm)	1853	1853	1853
	Weight	(kg)	935	1260	1300

## Accessories and options:

	Included	Optional
Master controller		•
DHW controller		•
Flexible hoses		•
Burst disc pressure relief kit		•
Exogel antifreeze kit		•
Anti-corrosion coating for installations close to the sea (special order)		•

## Minimum installation clearances:

**Front:** 1000mm

**Rear:** 0mm (Designed to back up to a wall)

**Left/Right:** 1000mm

## Terms and conditions apply:

Tyneham CO2 & CO2Q models all represent the output at Air 7°C & Water 65°C.

\* Coefficient of Performance (COP) rated at EN14825 test conditions Water 65°C / Air 7°C.

\*\* The sound power has been established in general accordance with BS EN ISO 3740: 2019 with a survey grade accuracy (sR0) = 4 dB.

\*\*\* Sound pressure level at 10m determined in accordance with Annex D of BS EN ISO 13487(TC): 2019.



# Tyneham CO2 dimensional drawings

## 65kW

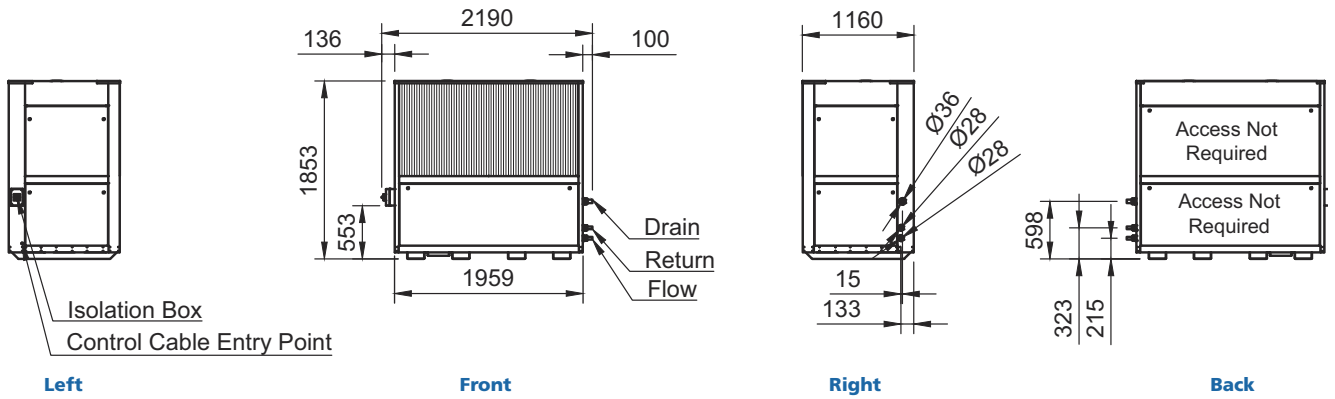

## 95kW

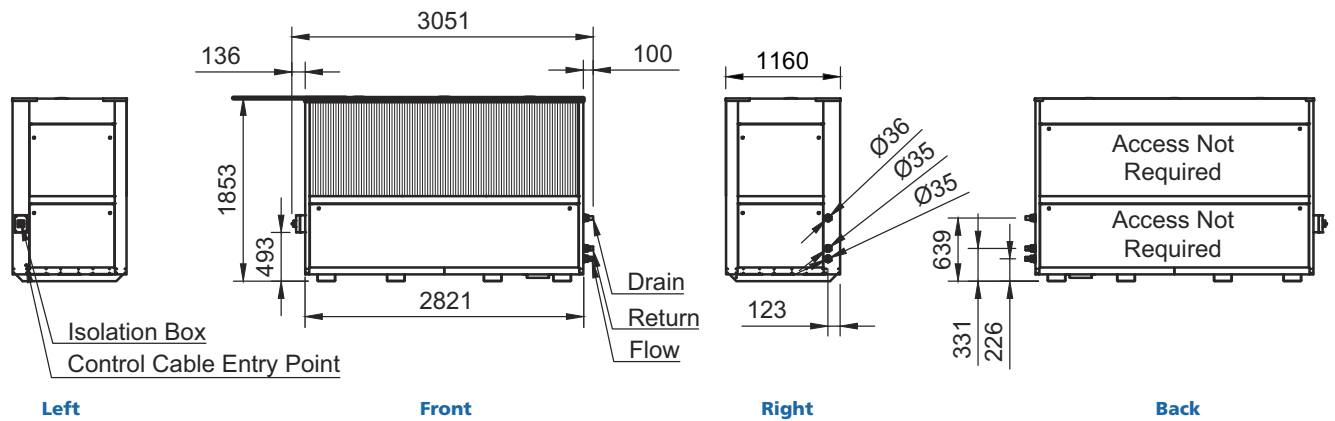

## 130kW

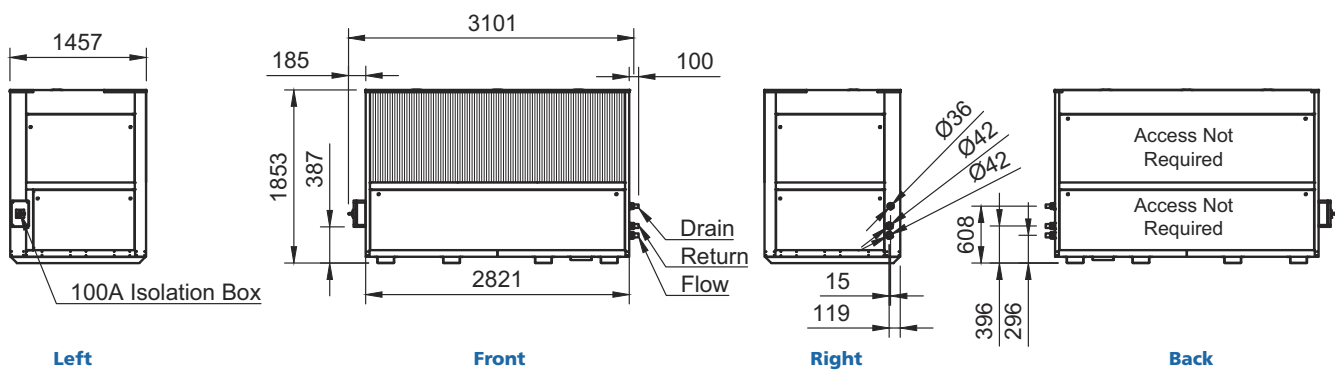

# Tyneham CO2Q

## technical specification

	Tyneham model	Units	65kW	95kW	130kW
ENERGY	Heat Pump Space Heating [55°C]	ErP rating	A+++	-	-
	Heat Pump Space Heating [55°C]	COP	3	3	3
	Heat Pump Space Heating [65°C]	ErP rating	A+++	-	-
	Heat Pump Space Heating [65°C]	COP*	3.4	3.4	3.4
	Refrigerant		R744	R744	R744
	Refrigerant Charge	(kg)	4.8	6.5	10
	Global Warming Potential	GWP	1	1	1
HEATING	Heating (A7/W65)	Capacity (kW)	65	95	130
	Heating (A7/W65)	Power Input (kW)	17	25	34
	Heating (A7/W65)	SCOP	3.5	3.5	3.5
	Max Flow Temperature	Max [°C]	70	70	70
	Air Temperature Range	Min/Max [°C]	(-15 no max)	(-15 no max)	(-15 no max)
SOUND	Sound Data Outdoor unit	Power Level dB(A)**	71	72	72
	Sound Data Outdoor unit	Pressure Level at 10m dB (A)***	40	40	40
CONNECTIONS	Pipework Connection Sizes	Heating Flow (mm)	28	35	42
	Pipework Connection Sizes	Heating Return (mm)	28	35	42
ELECTRICS	Electrical Supply	(v)	400	400	400
	Phase		Three	Three	Three
	Max Running Current	(amp)	45.07	67.55	82.19
	Fuse Rating	(amp)	63	80	100
DIMENSIONS	Width	(mm)	2190	3051	3101
	Depth	(mm)	1160	1160	1457
	Height	(mm)	2401	2401	2401
	Weight	(kg)	1000	1365	1590

### Accessories and options:

	Included	Optional
Master controller		•
DHW controller		•
Flexible hoses		•
Burst disc pressure relief kit		•
Exogel antifreeze kit		•
Anti-corrosion coating for installations close to the sea (special order)		•

### Minimum installation clearances:

**Front:** 1000mm

**Rear:** 0mm (Designed to back up to a wall)

**Left/Right:** 1000mm

### Terms and conditions apply:

Tyneham CO2 & CO2Q models all represent the output at Air 7°C & Water 65°C.

\* Coefficient of Performance (COP) rated at EN14825 test conditions Water 65°C / Air 7°C.

\*\* The sound power has been established in general accordance with BS EN ISO 3740: 2019 with a survey grade accuracy (sRO) = 4 dB.

\*\*\* Sound pressure level at 10m determined in accordance with Annex D of BS EN ISO 13487(TC): 2019.

# Tyneham CO2Q dimensional drawings

## 65kW

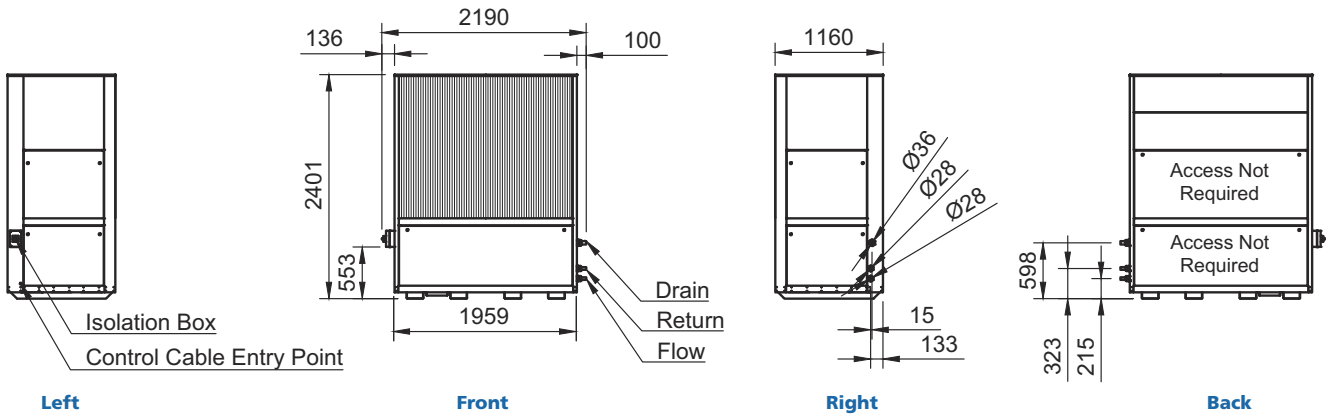

## 95kW

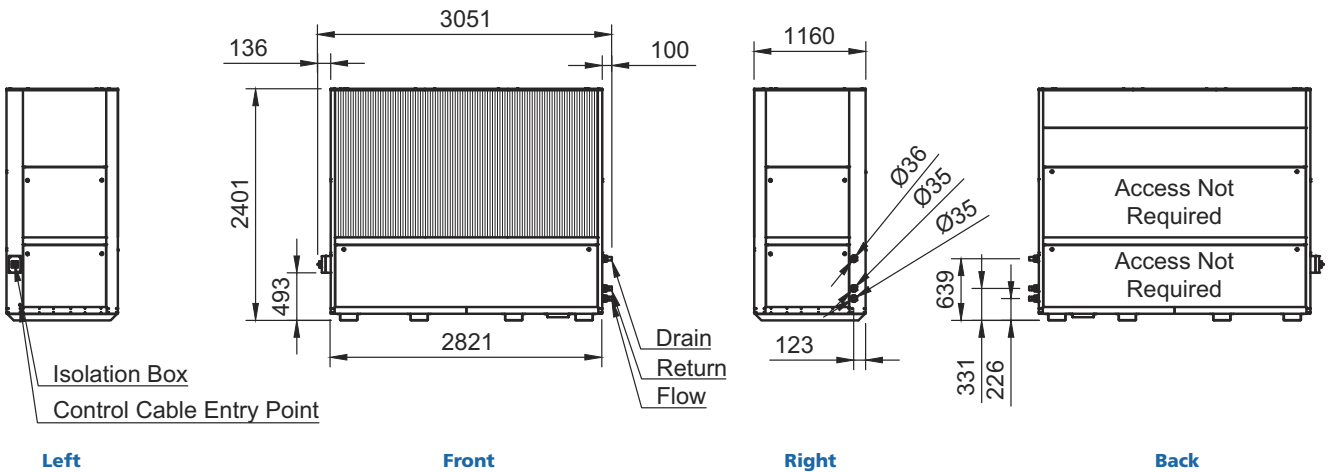

## 130kW

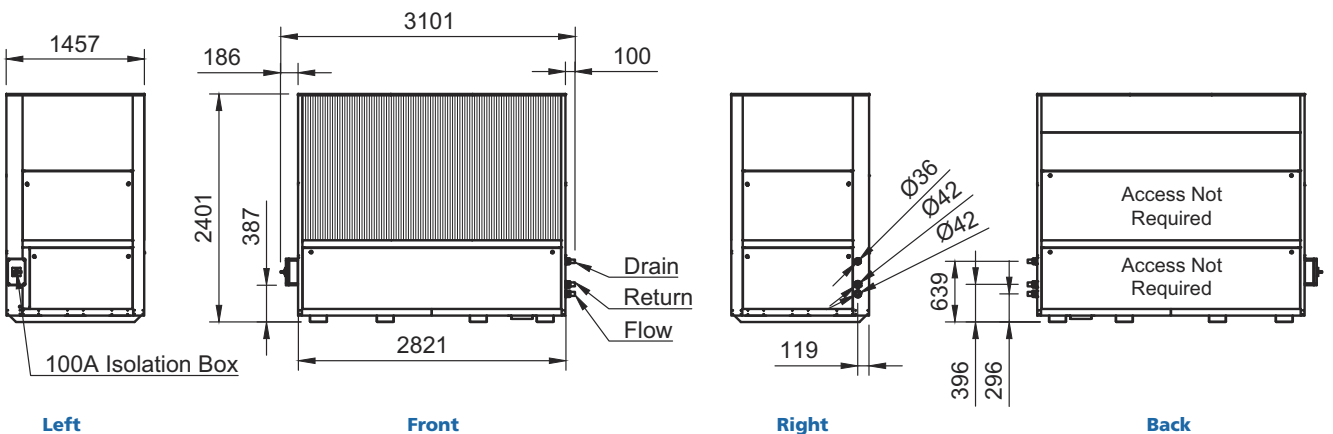

# Tyneham

6 models  
14-70 kW output

The Tyneham air source heat pump is one of the smallest commercial heat pumps on the market. With a Co-efficiency of performance (COP) rating up to 4.85 and low global warming potential to provide you with efficient low carbon heating.

The model is an air source heat pump for low carbon heating with inverter compressor and uses R32 refrigerant. The monobloc design means all components are housed in the main unit.

## Key benefits:

- > Monobloc air source heat pump
- > Single unit with the refrigeration cycle contained within the outdoor unit
- > Inverter controlled compressor to accurately match the heat demand
- > Low global warming potential due to the use of R32 refrigerant
- > Highly efficient coefficient of performance (COP)
- > Light and compact unit for ease of installation and delivery
- > Suited to larger installations – cascade systems to achieve higher output.
- > 2 year warranty (extended to 5 years if commissioned by Hamworthy)
- > Gold Fin anti-corrosion coating as standard on the 14 & 18 kW models and Blue Fin anti-corrosion coating on the 26, 32, 50 & 70 kW models
- > Back up and long-term support from our team of experienced engineers across the UK
- > Combine with Hamworthy modular boilers for a hybrid heating system



Scan to  
read more

As part of its commitment to tackling global climate change, Sunderland Council is now benefiting from reduced carbon emissions and energy consumption thanks to a new Hamworthy Tyneham heat pump system set up in a hybrid installation at its offices in Stansfield Business Centre.

# Tyneham

## Technical information

### 14 & 18 kW models

Technical Specification	Unit	14kW 1PH	14kW 3PH	18kW
Heat Pump Space Heating [35°C]	ErP rating	A+++	A+++	A+++
	SCOP	4.48	4.48	4.46
Heat Pump Space Heating [55°C]	ErP rating	A++	A++	A++
	SCOP	3.31	3.31	3.36
Heating (A7/W35)	Capacity (kW)	14.1	14.1	17.9
	Power Input (kW)	2.91	2.91	4.07
	COP*	4.85	4.85	4.4
Air Temperature Range	Min/Max (°C)	(-20 +40)	(-20 +40)	(-20 +40)
Sound Data Outdoor Unit	Power Level dB(A)**	68	68	68
Pipework Connection Sizes	Heating Flow (")	1	1	1
	Heating Return (")	1	1	1
Dimensions Outdoor Unit	Width (mm)	1044	1044	1044
	Depth (mm)	455	455	455
	Height (mm)	1409	1409	1409
Weight	kg	121	136	141
Electrical Data	Electrical Supply (v)	240	415	415
	Phase	Single	Three	Three
	Max Running Current (Amp)	29.2	9.7	12.2
	Fuse Rating (Amp)	32	25	25
Refrigerant Charge	R32 (kg)	3.2	3.2	3.5

## Dimensions

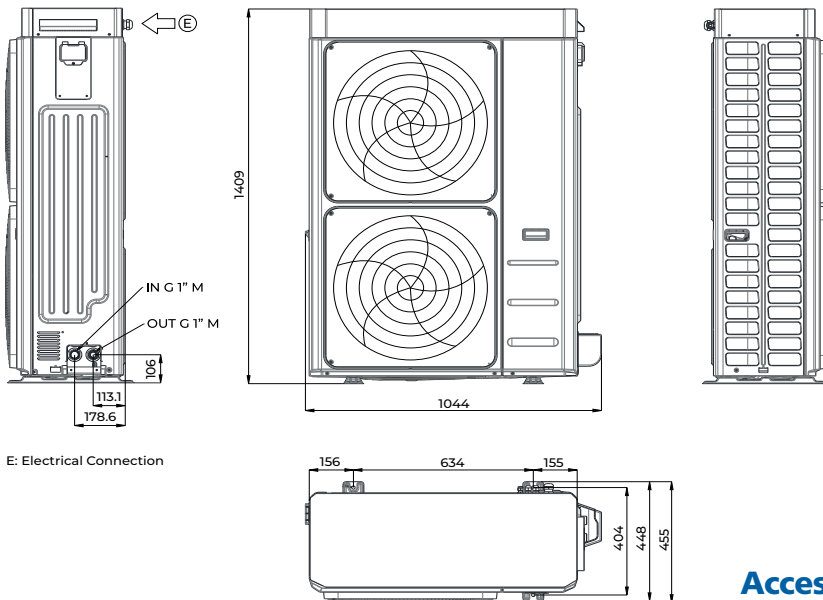

### Minimum installation clearances:

**Front:** 1500

**Rear:** 400

**Left:** 400

**Right:** 500

**Top:** 500

**Bottom:** 50

Side clearance of 1000mm when used in cascade

E: Electrical Connection

## Accessories and options

	Required	Optional
Control unit (sold separately)*		•
Flexible hoses		•
Anti-vibration rubber feet		•
Anti-corrosion coating for installations close to the sea (special order)		•

\*Optional control units are available for cascade and additional heating circuits, and where no BMS is present.

## Terms and conditions apply:

\* Coefficient of performance (COP) rated at EN14825 test conditions Water 35°C/ Air 7°C.

\*\* The sound levels refer to a fully loaded unit at standard nominal conditions according to EN 12102-1: 2013.

# Tyneham

## Technical information

### 26 & 32 kW

Technical Specification	Unit	26kW	32kW
Heat Pump Space Heating [35°C]	ErP rating	A++	A++
	SCOP	4.55	4.81
Heat Pump Space Heating [55°C]	ErP rating	A+	A+
	SCOP	3.14	3.14
Heating (A7/W35)	Capacity (kW)	26	32.1
	Power Input (kW)	6.44	7.84
	COP*	4.04	4.09
Air Temperature Range	Min/Max (°C)	(-20 +40)	(-20 +40)
Sound Data Outdoor Unit	Power Level dB(A)**	74	76
Pipework Connection Sizes	Heating Flow (")	1	1 1/4
	Heating Return (")	1	1 1/4
Dimensions Outdoor Unit	Width (mm)	1600	1600
	Depth (mm)	680	680
	Height (mm)	1315	1315
Weight	kg	240	255
Electrical Data	Electrical Supply (v)	415	415
	Phase	Three	Three
	Max Running Current (Amp)	23.3	27.1
	Fuse Rating (Amp)	25	32
Refrigerant Charge	R32 (kg)	4.3	5.1

## Dimensions

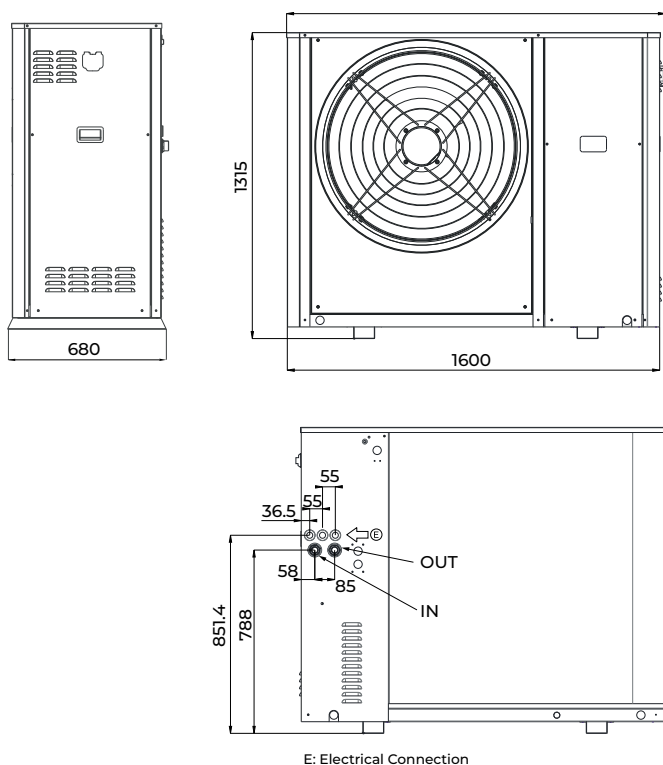

### Minimum installation clearances:

**Front:** 1500

**Rear:** 400

**Left:** 400

**Right:** 700

**Top:** 500

**Bottom:** 50

Side clearance of 700mm when used in cascade

### Accessories and options

	Required	Optional
Control unit (sold separately)*		•
Flexible hoses		•
Anti-vibration rubber feet		•
Anti-corrosion coating for installations close to the sea (special order)		•

\*Optional control units are available for cascade and additional heating circuits, and where no BMS is present.

### Terms and conditions apply:

\* Coefficient of performance (COP) rated at EN14825 test conditions Water 35°C/ Air 7°C.

\*\* The sound levels refer to a fully loaded unit at standard nominal conditions according to EN 12102-1: 2013.

# Tyneham

## Technical information

### 50 & 70 kW models

Technical Specification	Unit	50kW	70kW
Heat Pump Space Heating [35°C]	ErP rating	A++	A++
	SCOP	4.16	3.94
Heat Pump Space Heating [55°C]	ErP rating	A+	A+
	SCOP	3.08	3.04
Heating (A7/W35)	Capacity (kW)	50.2	66.8
	Power Input (kW)	12.2	16.3
	COP*	4.11	4.1
Air Temperature Range	Min/Max (°C)	(-20 +40)	(-20 +40)
Sound Data Outdoor Unit	Power Level dB(A)**	82	83
Pipework Connection Sizes	Heating Flow (")	1½	1½
	Heating Return (")	1½	1½
Dimensions Outdoor Unit	Width (mm)	1920	1920
	Depth (mm)	1110	1110
	Height (mm)	1920	1920
Weight	kg	535	595
Electrical Data	Electrical Supply (v)	415	415
	Phase	Three	Three
	Max Running Current (Amp)	54	70
	Fuse Rating (Amp)	63	100
Refrigerant Charge	R32 (kg)	8.5	12

## Dimensions

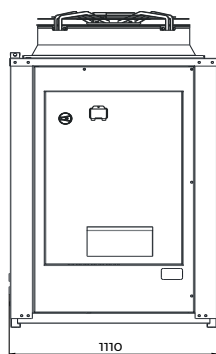

Left

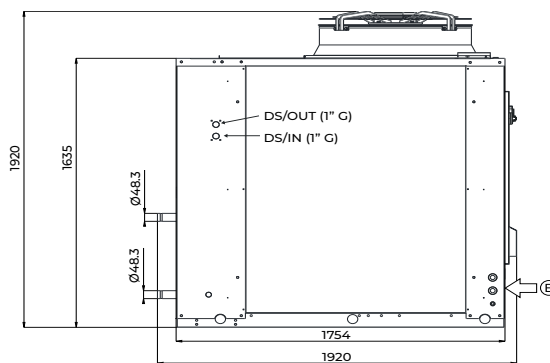

Back

### Minimum installation clearances:

**Front:** 1500

**Rear:** 1500

**Left:** 1200

**Right:** 1000

**Top:** 1500

**Bottom:** 50

Side clearance of 2200mm when used in cascade

## Accessories and options

	Required	Optional
Control unit (sold separately)*		•
Flexible hoses		•
Anti-vibration rubber feet		•
Anti-corrosion coating for installations close to the sea (special order)		•

\*Optional control units are available for cascade and additional heating circuits, and where no BMS is present.

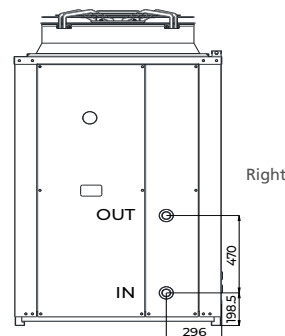

E: Electrical Connection

## Terms and conditions apply:

\* Coefficient of performance (COP) rated at EN14825 test conditions Water 35°C/ Air 7°C.

\*\* The sound levels refer to a fully loaded unit at standard nominal conditions according to EN 12102-1: 2013.

# Stratton mk3 wall hung boiler

7 models  
40-150 kW output

The Stratton mk3 is a wall hung condensing boiler offering a small and durable solution suitable for even the tightest plant rooms. Particularly suited to low height plantrooms, the boiler is less than 2 metres from ground to the top of the frame when mounted on our low height pipe kit.

Associated pumps and accessories are available to support system design.

## Product features:

- > 7 models available with 40, 60, 70, 80, 100, 120, 150kW output models
- > Wall hung condensing boiler
- > Stainless steel heat exchanger for added durability
- > Low height for tight plantrooms
- > Up to 5:1 turndown ratio
- > Up to 97% gross seasonal efficiency
- > NOx class 6
- > Single units can be cascaded for larger installations
- > Advanced sequence control for up to 16 boiler modules
- > Easy access for service and system cleaning
- > Connections in recess at base of the boiler
- > Suitable for natural gas (all sizes) and LPG (up to 120kW) applications
- > Full range of hydraulic separation options available
- > Room sealed flue options

A







Scan to read more

With a heating system that was reaching the end of its life, the Hull and East Yorkshire Centre for the Deaf was in urgent need of a replacement boiler that wasn't going to impact the aesthetics of the 1920's building.



When installed with a plate heat exchanger or low loss header, the Stratton mk3 can be fitted to old systems with peace of mind that the new boiler is protected from dirt and debris in an existing secondary circuit.

For more information on our range of hydraulic system separators, see page 38.



# Stratton mk3

## Technical information

	Units	S3-40	S3-60	S3-70	S3-80	S3-100	S3-120	S3-150*	
Energy	Building Regulations Part L seasonal efficiency	% gross	97.6	97.4	97.5	97.5	97.5	97.8	
	ErP efficiency rating		A	A	A	N/A	N/A	N/A	
	Maximum boiler output (80-60 Deg C, NG & LPG)*	kW	38.8	53.4	67.8	77.8	93.4	116.8	141.1
	Maximum boiler output (50-30 Deg C, NG & LPG)*	kW	42.2	58	73.6	84.4	101.3	127.8	154.5
	Minimum boiler output (80-60 Deg C, NG & LPG)*	kW	8	11	14	19.2	19.2	24	29
	Standby losses	W	52	54	56	63	63	72	69
Water	Water content	litres	3	4	4.5	7.5	7.5	9.5	11
	Nominal water flow rate	l/sec	0.48	0.66	0.83	1.16	1.19	1.43	1.73
	Minimum water flow rate	l/sec	0.16	0.32	0.32	0.64	0.64	0.83	0.96
	System design flow rate @ 11 Deg C rise	l/sec	0.87	1.19	1.52	1.73	2.17	2.6	3.14
	Water pressure loss @ 11 Deg C rise	mBar	1539	1560	1890	1043	1457	1648	2278
	System design flow rate @ 20 Deg C rise	l/sec	0.48	0.72	0.84	0.96	1.19	1.43	1.79
	Water pressure loss @ 20 Deg C rise	mBar	459	470	520	318	449	515	701
	System design flow rate @ 25 Deg C rise	l/sec	0.38	0.52	0.67	0.76	0.95	1.14	1.38
	Water pressure loss @ 25 Deg C rise	mBar	223	305	306	203	287	335	441
	Minimum water pressure (cold)	barg	1	1	1	1	1	1	1
	Maximum water pressure	barg	4	4	4	6	6	6	6
	Maximum flow temperature	Deg C	85	85	85	85	85	85	85
Gas	Maximum gas inlet pressure (NG)	mBar	25	25	25	25	25	25	
	Nominal gas inlet pressure (NG)	mBar	20	20	20	20	20	20	
	Minimum gas inlet pressure (NG)	mBar	17	17	17	17	17	17	
	Maximum gas inlet pressure (LPG)	mBar	45	45	45	45	45	N/A	
	Nominal gas inlet pressure (LPG)	mBar	37	37	37	37	37	N/A	
	Minimum gas inlet pressure (LPG)	mBar	25	25	25	25	25	N/A	
	Maximum gas flow rate (NG)	m <sup>3</sup> /hr	4.2	5.8	7.4	8.5	10.2	12.7	15.3
	Maximum gas flow rate (LPG)	m <sup>3</sup> /hr	1.6	2.3	2.9	3.3	3.9	4.9	N/A
Flue	Maximum flue gas temperature (80-60 Deg C, NG)	Deg C	79	75.5	74.5	66.5	72.5	73.5	73
	Dry Nox emission (0% excess oxygen, dry air free)	mg/kWh	36	39	39	39	39	39	39
Elec	Electrical supply		230V AC/50Hz	230V AC/50Hz	230V AC/50Hz	230V AC/50Hz	230V AC/50Hz	230V AC/50Hz	230V AC/50Hz
	Power consumption (at maximum modulation)	W	67	107	121	94	143	233	260
Misc	Approx. shipping weight (empty)	kg	45	51	55	77	77	81	100
	Noise emission @ 1M (maximum modulation)	db (A)	50	59	60.2	67.7	64.7	64.9	59.2

\* LPG option for 150kw is not available

# Stratton mk3

## Technical information

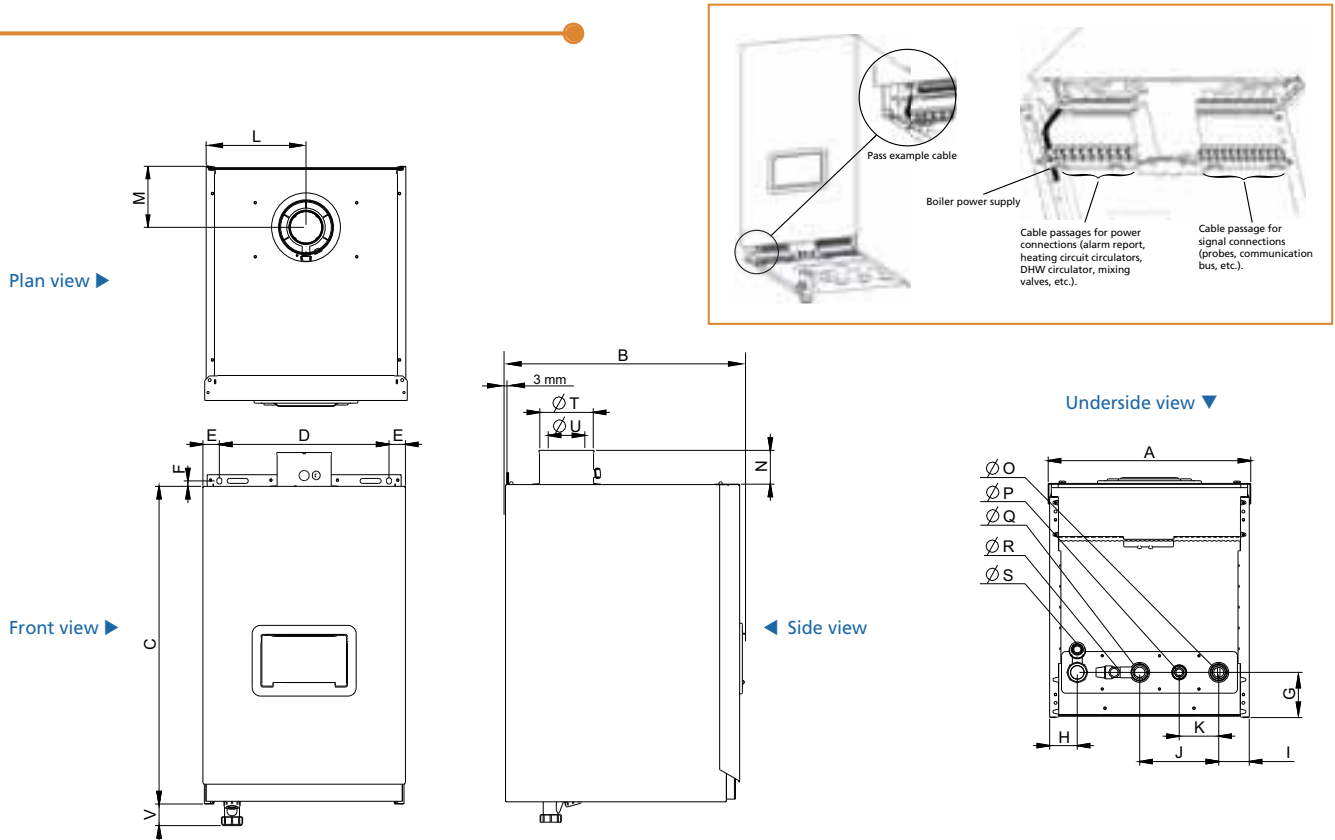

		Boiler Models in kW						
		S3-40	S3-60	S3-70	S3-80	S3-100	S3-120	S3-150
A	Boiler width	(mm)					487	
B	Boiler depth	(mm)			577		668	
C	Boiler height	(mm)			764		895	
D	Fixing centers	(mm)					408	
E	Distance of fixings to side of boiler	(mm)					36	
F	Fixing point centers above top of casing	(mm)					17	
G	Center of connections to rear of boiler	(mm)					108,5	
H	Center of siphon outlet to side casing	(mm)		66,5		65,5		
I	Center of return connection from casing side	(mm)		73,5		74,5		
J	Centers between flow and return connections	(mm)					190	
K	Centers between gas inlet and return connection	(mm)					95	
L	Center of flue from side	(mm)					240	
M	Center of flue from rear	(mm)			146,5		123	
N	Flue connection socket height	(mm)					83	
Ø O	Return connection						G 1 1/4"	
Ø P	Gas inlet connection						G 1"	
Ø Q	Flow connection						G 1 1/4"	
Ø R	Pressure relief valve						G 1/2" (female)	
Ø S	Condensate outlet	(mm)		24				
Ø T	Air inlet	(mm)		125		150		
Ø U	Flue duct	(mm)		80		100		
V	Siphon outlet from the bottom of the casing	(mm)					52	

**Recommended Clearance – All Models**  
**Front:** 800mm    **Sides:** 250mm\*    **Top:** Dependent on flue choice

\* Side clearance is preferred but not compulsory.

# Wessex ModuMax mk3 stainless steel modular boiler

15 models  
97-762 kW output

This lightweight, low water content boiler is ideal for city centre, basement or rooftop plant rooms. Individual boiler modules can be stacked one, two or three high in up to 15 combinations.

## Key benefits:

- > High efficiency fully modulating condensing pre-mix floor standing boiler
- > Stainless steel heat exchanger
- > Up to 15: 1 turn down 40°C differential temperature
- > Up to 762kW output in less than one square metre footprint
- > Close load matching
- > Passes through a standard doorway
- > Space-saving stacked modular design
- > 10 bar rated heat cell
- > 90°C maximum flow temperature
- > Integral boiler sequence controller
- > 10 year heat exchanger warranty

## Options:

- > External boiler sequencing cascade controller
- > Room and outside temperature sensors
- > LPB bus communications module
- > Zone control
- > DHW cylinder sensor kit
- > Pipework header kit



Combine our Wessex Modumax mk3 boiler with our Tyneham air source heat pump for a low carbon hybrid heating system.



### Ultra compact

762kW in less than one square metre of floor space.

Even the largest 3-high stack will pass through a standard doorway.

Can be broken down into individual modules for difficult to access plant rooms.



Scan to read more

The prestigious Grade 1 listed St Paul's Cathedral is fitted with a flexible and efficient modular boiler and hot water solution from Hamworthy

# Wessex ModuMax mk3

## Technical information

### 97-116 kW models

FLOOR STANDING BOILERS

Boiler model		Unit	97/97H	97/194V	97/291V	116/116H	116/232V	116/348V
Energy	Number of modules		1	2	3	1	2	3
	Building regulations Part L seasonal efficiency	%	94.9	94.9	94.9	93.1	93.1	93.1
	BS EN 15502 seasonal efficiency	% gross	95.2	95.2	95.2	93.4	93.4	93.4
	Boiler output 50/30 °C	kW	97.2	194.4	291.6	116.2	232.5	348.7
	Boiler output 80/60 °C	kW	95.7	191.4	287.1	115.2	230.4	345.6
	Boiler input (gross) maximum	kW	109.0	218.0	327.0	133.0	266.0	399.0
	Boiler input (nett) maximum	kW	98.2	196.4	294.6	119.8	239.6	359.4
Water	Boiler output minimum 80/60 °C	kW	19.1	19.1	19.1	23.5	23.5	23.5
	Design flow rate @ 40°C ΔT rise	l/s	0.6	1.2	1.8	0.7	1.4	2.1
	Water side pressure loss @ 40°C ΔT rise	mbar	5	5	5	7	7	7
	Design flow rate @ 30°C ΔT rise	l/s	0.8	1.6	2.4	1.0	2.0	3.0
	Water side pressure loss @ 30°C ΔT rise	mbar	9	9	9	14	14	14
	Design flow rate @ 20°C ΔT rise	l/s	1.2	2.4	3.6	1.4	2.8	4.2
	Water side pressure loss @ 20°C ΔT rise	mbar	20	20	20	27	27	27
	Design flow rate @ 11°C ΔT rise	l/s	2.2	4.4	6.6	2.6	5.2	7.8
	Water side pressure loss @ 11°C ΔT rise	mbar	61	61	61	91	91	91
	Operating water pressure minimum	barg	Dependent on differential temperature (See full brochure)					
Operating water pressure maximum	barg	10	10	10	10	10	10	
Maximum operating water temperature	°C	90	90	90	90	90	90	
Gas	Gas flow rate natural gas (G20) – maximum	m <sup>3</sup> /h	10.8	21.6	32.4	12.7	25.4	38.1
	Gas inlet pressure natural gas (G20) – min/nom/max	mbar	17.5 min / 20.0 nom / 25.0 max					
Flue	Approx. flue gas volume @ 15°C, 9.3-9.8% CO <sub>2</sub>	m <sup>3</sup> /h	143	286	429	160	320	480
	Flue gas temperature @80/60 °C	°C	83	83	83	83	83	83
	NOX emission (0% excess oxygen, dry air free) European Class 6	mg/kWh	39.8	39.8	39.8	34.3	34.3	34.3
	Pressure at flue outlet	Pa	150	150	150	150	150	150
Misc.	Nominal supply voltage		230V 1Ph 50Hz					
	Approx. shipping weight	kg	180	355	540	180	355	540
	Noise emissions/module @ 1m @max. modulation	Max dB (A)	60	60	60	60	60	60

### Dimensions 97-116kW models

Height to top of flue terminal (A)	
No. of modules	mm
3	2084
2	1543

**Note:** All dimensions in mm unless otherwise stated.

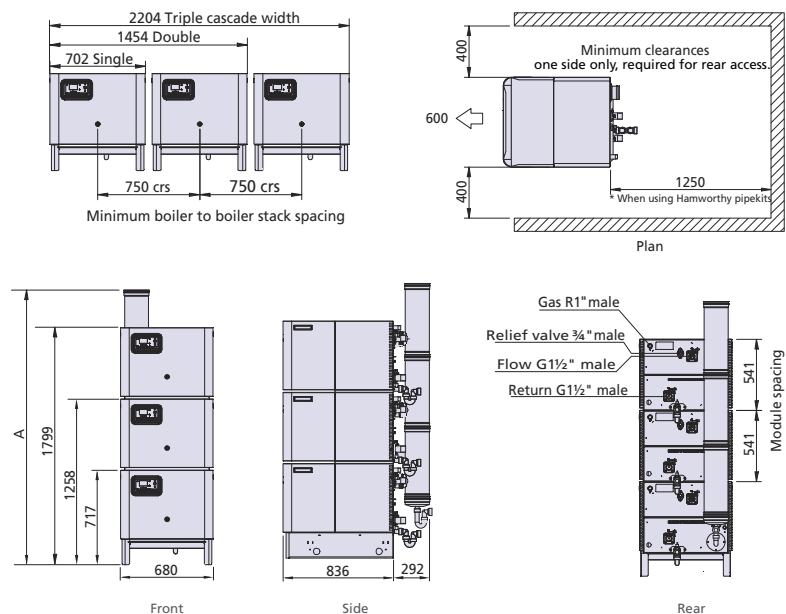

# Wessex ModuMax mk3

## Technical information

### 147-254 kW models

Boiler model		Unit	147/ 147H	147/ 294V	147/ 441V	196/ 196H	196/ 392V	196/ 588V	254/ 254H	254/ 508V	254/ 762V	
Number of modules			1	2	3	1	2	3	1	2	3	
Energy	Building regulations Part L seasonal efficiency	% gross	94.8	94.8	94.8	93.9	93.9	93.9	95.0	95.0	95.0	
	BS EN 15502 seasonal efficiency		95.2	95.2	95.2	94.1	94.1	94.1	95.3	95.3	95.3	
	Boiler output 50/30 °C	kW	147.4	294.8	442.2	196.3	392.6	588.9	254.4	508.7	763.1	
	Boiler output 80/60 °C	kW	142.8	285.6	428.4	191.6	383.2	574.8	239.8	479.6	719.4	
	Boiler input (gross) maximum	kW	163.0	326.0	489.0	219.0	428.7	657.0	275.0	550.0	825.0	
	Boiler input (nett) maximum	kW	146.8	293.6	440.3	197.2	394.4	591.6	247.6	495.3	742.9	
	Boiler output minimum 80/60 °C	kW	28.7	28.7	28.7	38.6	38.6	38.6	48.4	48.4	48.4	
Water	Design flow rate @ 40°C ΔT rise	l/s	0.9	1.8	2.7	1.2	2.4	3.6	1.5	3.0	4.5	
	Water side pressure loss @ 40°C ΔT rise	mbar	36	36	36	62	62	62	100	100	100	
	Design flow rate @ 30°C ΔT rise	l/s	1.2	2.4	3.6	1.6	3.2	4.8	2.0	4.0	6.0	
	Water side pressure loss @ 30°C ΔT rise	mbar	60	60	60	120	120	120	180	180	180	
	Design flow rate @ 20°C ΔT rise	l/s	1.8	3.6	5.4	2.4	4.8	7.2	3.0	6.0	9.0	
	Water side pressure loss @ 20°C ΔT rise	mbar	145	145	145	246	246	246	395	395	395	
	Design flow rate @ 11°C ΔT rise	l/s	3.3	6.6	9.9	4.3	8.6	12.9	5.4	10.8	16.2	
	Water side pressure loss @ 11°C ΔT rise	mbar	500	500	500	850	850	850	1300	1300	1300	
	Operating water pressure minimum	barg	Dependent on differential temperature (See full brochure)									
	Operating water pressure maximum	barg	10	10	10	10	10	10	10	10	10	
Gas	Maximum operating water temperature	°C	90	90	90	90	90	90	90	90	90	
	Gas flow rate natural gas (G20) – maximum	m <sup>3</sup> /h	16.0	32.0	48.0	21.4	42.8	64.2	27.9	55.8	83.7	
Flue	Gas inlet pressure natural gas (G20) – min/nom/max	mbar	17.5 min / 20.0 nom / 25.0 max									
	Approx. flue gas volume @ 15°C, 9.3-9.8% CO <sub>2</sub>	m <sup>3</sup> /h	214	428	642	279	558	837	354	708	1062	
	Flue gas temperature @80/60 °C	°C	78	78	78	83	83	83	82	82	82	
	NO <sub>x</sub> emission (0% excess oxygen, dry air free) European Class 6	mg/kWh	37.7	37.7	37.7	39.9	39.9	39.9	38.8	38.8	38.8	
Misc.	Pressure at flue outlet	Pa	89	89	89	90	90	90	150	150	150	
	Nominal supply voltage		230V 1Ph 50Hz									
	Approx. shipping weight	kg	226	452	678	226	452	678	226	452	678	
Noise emissions/module @ 1m @max. modulation		Max dB	65	65	65	65	65	65	65	65	65	

### Dimensions 147-254kW models

Height to top of flue terminal (A)	
No. of modules	mm
3	2084
2	1543

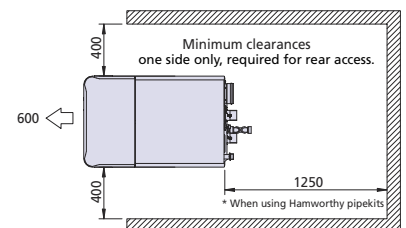
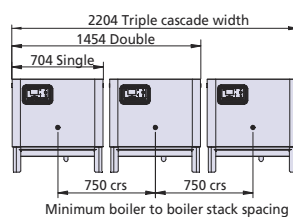

**Note:** All dimensions in mm unless otherwise stated.

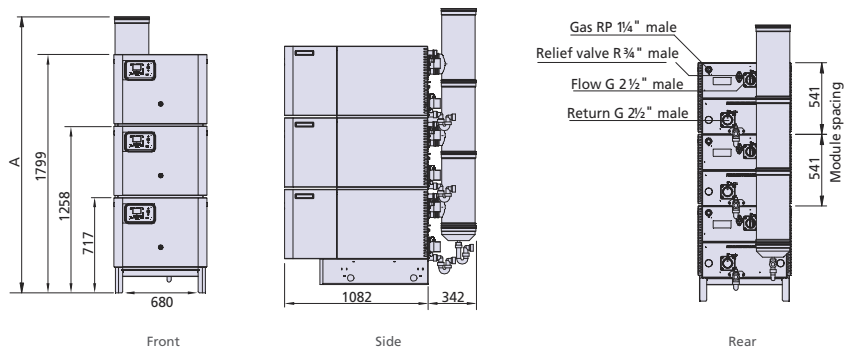

# Upton floor standing aluminium modular boiler

18 models  
98-1046 kW output

The compact, space-saving, vertically stacked design means more than 1MW output can sit on less than 1 square metre footprint.

## Key benefits:

- > Highly efficient
- > High turndown ratio enables close load matching for improved efficiencies
- > Gas and water connections identical across range
- > Easy access for service and system cleaning
- > Advanced controls platform with integrated sequence control
- > Low noise for installation close to building occupants
- > 6 bar rated heat cell
- > Air inlet filter for clean combustion and reduced noise
- > 5 year heat exchanger warranty

## Options:

- > NEW pipework header kits with optional matched pumps (see Upton brochure for details)
- > Low loss header with integrated air and dirt separator
- > 3 port manifold
- > Blanking plates for left and right sided pipe installation
- > Room and outside temperature sensors
- > LPB bus communications module
- > Multiple heating circuit control (VT & CT)
- > DHW control with Legionella protection function



### Aluminium sectional heat exchanger

- Quick to respond with low water content
- Excellent heat transfer properties
- Lightweight and compact
- Parallel water flow for an even surface temperature
- 5-year warranty





# Upton

## Technical information

### 100-150 kW models

Boiler model		Units	UF100-1	UF200-2	UF300-3	UF150-1	UF-300-2	UF450-3
Energy	No. of modules		1	2	3	1	2	3
	Building regulations Part L seasonal efficiency	% gross	97.4	97.4	97.4	95.6	95.6	95.6
	Boiler output 80/60°C	kW	89.1	178.2	267.3	134.5	269.0	403.5
	Boiler output 50/30°C	kW	98.6	197.2	295.8	147.3	294.6	441.9
	Boiler input gross (maximum)	kW	103.0	206.0	309.0	154.6	309.2	463.8
	Boiler input nett (maximum)	kW	92.8	185.5	278.3	139.2	278.4	417.6
Water	Boiler output 80/60°C (minimum)	kW	17.8	17.8	17.8	26.9	26.9	26.9
	Water content	litres	9.0	18.0	27.0	12.6	25.2	37.8
	System design flow rate @ 11°C ΔT rise	l/s	2.2	4.3	6.5	3.3	6.5	9.8
	Water side pressure loss @ 11°C ΔT rise	mbar	736	736	736	820	820	820
	System design flow rate @ 20°C ΔT rise	l/s	1.2	2.4	3.6	1.8	3.6	5.4
	Water side pressure loss @ 20°C ΔT rise	mbar	225	225	225	250	250	250
	Maximum water pressure	barg	6	6	6	6	6	6
	Maximum flow temperature setting	°C	85	85	85	85	85	85
Gas	Minimum flow temperature setting	°C	30	30	30	30	30	30
	Gas flow rate (maximum)	m <sup>3</sup> /hr	9.8	19.6	29.5	14.7	29.5	44.2
Flue	Gas inlet pressure – minimum/nominal/maximum	mbar	17.5 min / 20.0 nom / 25.0 max					
	Approx flue gas volume @ 72°C, 9.0% CO <sub>2</sub>	m <sup>3</sup> /hr	155	310	465	233	466	699
	Maximum flue gas temperature @ 80/60°C	°C	72	72	72	72	72	72
	Pressure available at flue connection	Pa	150	150	150	150	150	150
		mbar	1.5	1.5	1.5	1.5	1.5	1.5
	NO <sub>x</sub> , pond, H <sub>s</sub> (gross) emission (0% excess oxygen, dry air)	mg/kWh	33	33	33	32	32	32
	NO <sub>x</sub> Class		6	6	6	6	6	6
Misc.	Electrical supply		230V~50Hz	230V~50Hz	230V~50Hz	230V~50Hz	230V~50Hz	230V~50Hz
	Approx shipping weight	kg	152	286	420	177	336	495
	Noise emission @1m @max modulation (per module)	Max dB (A)	55.8	55.8	55.8	59.4	59.4	59.4

### Dimensions 100-150kW models

Height to top of flue terminal (A)	
No. of modules	mm
3	1990
2	1376

**Note:** All dimensions in mm unless otherwise stated.

**\*Note:** the rear clearance allows for installation of a Hamworthy pipe kit. If installing a third stack of boilers either an additional 500mm clearance would be required behind the pipe kit or the spacer spool (400mm) would need to be fitted between the second and third boiler stack.

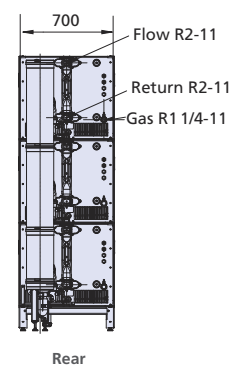
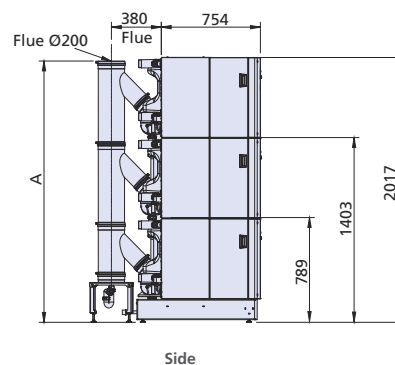
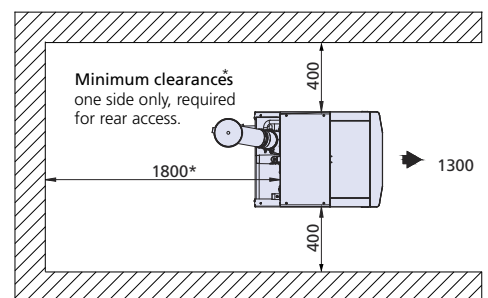
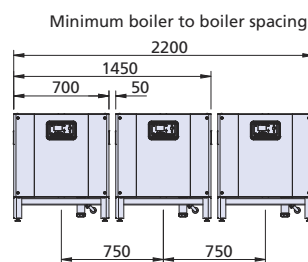

# Upton

## Technical information

### 200-250 kW models

FLOOR STANDING BOILERS

Boiler model		Units	UF200-1	UF400-2	UF600-3	UF250-1	UF500-2	UF750-3
Energy	No. of modules		1	2	3	1	2	3
	Building regulations Part L seasonal efficiency	% gross	96.5	96.5	96.5	94.3	94.3	94.3
	Boiler output 80/60°C	kW	181.7	363.4	545.1	229.4	458.8	688.2
	Boiler output 50/30°C	kW	197.9	395.8	593.7	246.9	493.8	740.7
	Boiler input gross (maximum)	kW	208.9	417.7	626.6	261.9	523.9	785.8
	Boiler input nett (maximum)	kW	188.1	376.1	564.2	235.9	471.7	707.6
Water	Boiler output 80/60°C (minimum)	kW	36.3	36.3	36.3	45.9	45.9	45.9
	Water content	litres	16.2	32.4	48.6	19.8	39.6	59.4
	System design flow rate @ 11°C ΔT rise	l/s	4.3	8.7	13.0	5.4	10.9	16.3
	Water side pressure loss @ 11°C ΔT rise	mbar	710	710	710	767	767	767
	System design flow rate @ 20°C ΔT rise	l/s	2.4	4.8	7.2	3	6.0	9.0
	Water side pressure loss @ 20°C ΔT rise	mbar	217	217	217	234	234	234
	Maximum water pressure	barg	6	6	6	6	6	6
	Maximum flow temperature setting	°C	85	85	85	85	85	85
Gas	Minimum flow temperature setting	°C	30	30	30	30	30	30
	Gas flow rate (maximum)	m <sup>3</sup> hr	19.1	38.2	57.3	25.0	49.9	74.9
Flue	Gas inlet pressure - minimum/nominal/maximum	mbar	17.5 min / 20.0 nom / 25.0 max					
	Approx flue gas volume @ 72°C, 9.0% CO <sub>2</sub>	m <sup>3</sup> hr	314	628	942	394	788	1182
	Maximum flue gas temperature @ 80/60°C	°C	72	72	72	72	72	72
	Pressure available at flue connection	Pa	150	150	150	150	130	130
		mbar	1.5	1.5	1.5	1.5	1.3	1.3
	NO <sub>x</sub> , pond, H <sub>s</sub> (gross) emission (0% excess oxygen, dry air)	mg/kWh	33	33	33	35	35	35
Misc.	NO <sub>x</sub> Class		6	6	6	6	6	6
	Electrical supply		230V~50Hz	230V~50Hz	230V~50Hz	230V~50Hz	230V~50Hz	230V~50Hz
	Approx shipping weight	kg	220	422	624	247	476	705
	Noise emission @1m @max modulation (per module)	Max dB (A)	59.7	59.7	59.7	58.5	58.5	58.5

### Dimensions 200-250kW models

Height to top of flue terminal (A)	
No. of modules	mm
3	1990
2	1376

**Note:** All dimensions in mm unless otherwise stated.

**\*Note:** the rear clearance allows for installation of a Hamworthy pipe kit. If installing a third stack of boilers either an additional 500mm clearance would be required behind the pipe kit or the spacer spool (400mm) would need to be fitted between the second and third boiler stack.

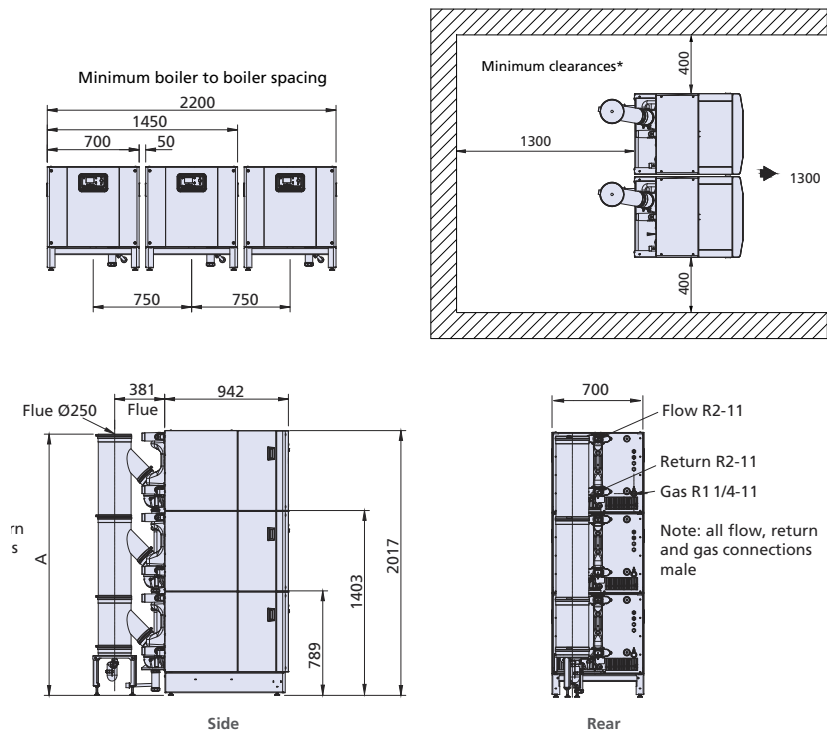

# Upton

## Technical information

### 300-350 kW models

Boiler model		Units	UF300-1	UF600-2	UF900-3	UF350-1	UF700-2	UF1050-3
Energy	No. of modules		1	2	3	1	2	3
	Building regulations Part L seasonal efficiency	% gross	95.6	95.6	95.6	96.9	96.9	96.9
	Boiler output 80/60°C	kW	273.0	546.0	819.0	316.4	632.8	949.2
	Boiler output 50/30°C	kW	295.9	591.8	887.7	348.9	697.8	1046.7
	Boiler input gross (maximum)	kW	314.6	629.1	943.7	360.8	721.6	1082.5
	Boiler input nett (maximum)	kW	283.3	566.5	849.8	324.9	649.8	974.8
Water	Boiler output 80/60°C (minimum)	kW	54.6	54.6	54.6	63.3	63.3	63.3
	Water content	litres	23.4	46.8	70.2	27.0	54.0	81.0
	System design flow rate @ 11°C ΔT rise	l/s	6.5	13.0	19.6	7.6	15.2	22.8
	Water side pressure loss @ 11°C ΔT rise	mbar	807	807	807	835	835	835
	System design flow rate @ 20°C ΔT rise	l/s	3.6	7.2	10.8	4.2	8.4	12.6
	Water side pressure loss @ 20°C ΔT rise	mbar	246	246	246	255	255	255
	Maximum water pressure	barg	6	6	6	6	6	6
	Maximum flow temperature setting	°C	85	85	85	85	85	85
Gas	Minimum flow temperature setting	°C	30	30	30	30	30	30
	Gas flow rate (maximum)	m <sup>3</sup> /hr	30.0	60.0	89.9	34.4	68.8	103.1
Flue	Gas inlet pressure – minimum/nominal/maximum	mbar	17.5 min / 20.0 nom / 25.0 max					
	Approx flue gas volume @ 72°C, 9.0% CO <sub>2</sub>	m <sup>3</sup> /hr	474	948	1422	543	1086	1629
	Maximum flue gas temperature @ 80/60°C	°C	72	72	72	72	72	72
	Pressure available at flue connection	Pa	100	100	80	110	70	60
		mbar	1.0	1.0	0.8	1.1	0.7	0.6
	NO <sub>x</sub> , pond, H <sub>s</sub> (gross) emission (0% excess oxygen, dry air)	mg/kWh	34	34	34	36	36	36
Misc.	NO <sub>x</sub> Class		6	6	6	6	6	6
	Electrical supply		230V~50Hz	230V~50Hz	230V~50Hz	230V~50Hz	230V~50Hz	230V~50Hz
	Approx shipping weight	kg	287	551	815	310	597	884
	Noise emission @1m @max modulation (per module)	Max dB (A)	60.9	60.9	60.9	60.9	60.9	60.9

### Dimensions 300-350kW models

Height to top of flue terminal (A)	
No. of modules	mm
3	1990
2	1376

Flue depth centreline (B)	
Models	mm
3UF600-2 & UF900-3	381
2UF700-2 & UF1050-3	450

**Note:** All dimensions in mm unless otherwise stated.

**\*Note:** the rear clearance allows for installation of a Hamworthy pipe kit. If installing a third stack of boilers either an additional 500mm clearance would be required behind the pipe kit or the spacer spool (400mm) would need to be fitted between the second and third boiler stack.

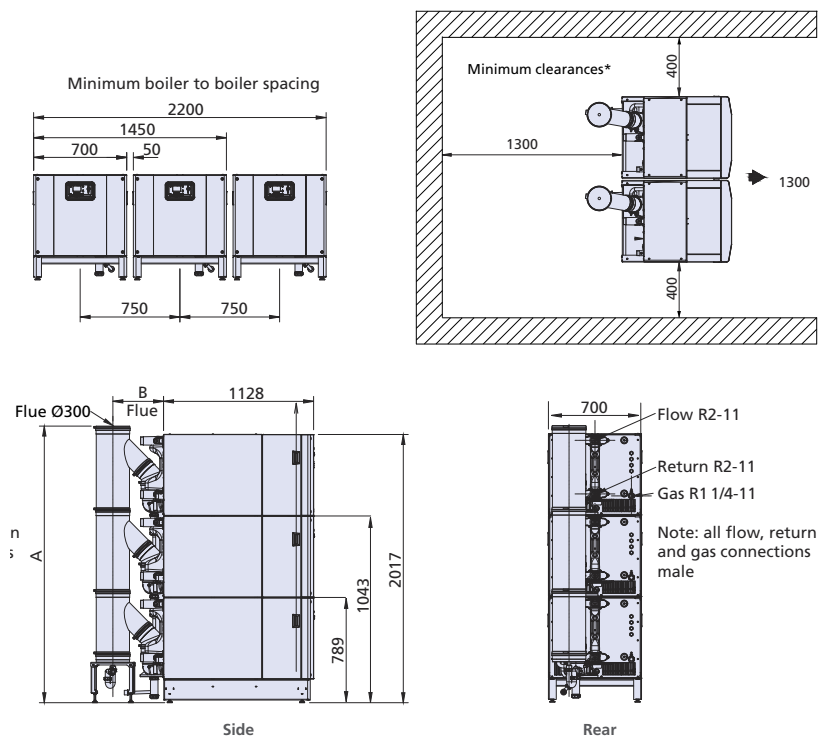

# Varmax floor standing stainless steel boiler

10 models  
127-637 kW output

This boiler has twin return connections to improve operating efficiency in split temperature systems. Installation is also simplified with no requirement for a primary circuit saving you time and money.

## Key benefits:

- > Stainless steel heat exchanger
- > Wide differential temperature
- > 5-year heat exchanger warranty
- > Internal circulation pump with non-return eliminates the need for system pump over-run
- > Simplified installation with no requirement for a primary circuit with low loss header
- > Twin return connections for maximum operating efficiency
- > Well insulated for low standby losses
- > Integral boiler sequence controller for up to 16 boiler modules
- > 5 year warranty

## Options:

- > Natural gas or LPG
- > Hamworthy Flue systems for 4 models 120 - 225
- > Room and outside temperature sensors
- > LPB bus communications module
- > Multiple heating circuit control (VT & CT)
- > DHW control with Legionella protection function



### No minimum flow

Thanks to an internal circulation loop and pump the boiler does not need to be installed in a traditional primary circuit, removing the need to purchase and install ancillary equipment such as a low loss header and pumps.



Scan to  
read more

2 x Varmax 180 boilers were chosen due to their reliability for this flagship nursing and care home in Poole.

# Varmax

## Technical information

Boiler model		Unit	120	140	180	225	275	320	390	450	525	600
Energy	Building regulation seasonal efficiency gross	%	96.13	96.13	96.33	96.33	96.24	96.24	96.22	96.22	96.22	96.22
	Boiler output 50/30 °C	kW	127	148	191	238	290	338	415	478	558	637
	Boiler output 80/60 °C	kW	117	136	175	219	268	312	381	439	513	586
	Boiler input (gross) maximum	kW	120.0	140.0	180.0	225.0	275.0	320.0	390.0	450.0	525	600
	Boiler input (net) maximum	kW	108.0	126.0	162.0	203.0	248.0	288.0	351.0	405.0	473	541
	Boiler output minimum 80/60°C	kW	27.3	27.2	41.8	41.8	64.3	64.3	85.0	84.7	118	118
Water	System design flow rate @ 30°C ΔT rise	l/s	0.9	1.1	1.4	1.7	2.1	2.5	3.0	3.5	4.08	4.69
	Water side pressure loss @ 30°C ΔT rise	mbar	27	33	25	36	36	53	34	43	60	75
	System design flow rate @ 20°C ΔT rise	l/s	1.4	1.6	2.1	2.6	3.2	3.7	4.6	5.3	6.14	7
	Water side pressure loss @ 20°C ΔT rise	mbar	60	75	57	81	82	119	77	97	86	107
	System design flow rate @ 11°C ΔT rise	l/s	2.5	2.9	3.8	4.7	5.8	6.8	8.3	9.5	11.17	12.77
	Water side pressure loss @ 11°C ΔT rise	mbar	198	248	188	268	271	393	255	321	335	450
	Water pressure maximum	barg	6	6	6	6	6	6	6	6	6	6
	Maximum operating water temperature	°C	85	85	85	85	85	85	85	85	85	85
Gas	Gas flow rate natural gas (G20) - maximum	m³/hr	12.7	14.8	19.1	23.8	29.1	33.9	41.3	47.6	55.6	63.5
	Gas inlet pressure natural gas (G20)	mbar	17.5 min / 20.0 nom / 25.0 max									
Flue	Flue gas temperature @80/60 °C	°C	60.8	62.1	61.0	62.3	61.7	63.4	62.5	64.8	64.4	66.6
	NOx emission (0% excess oxygen, dry air free) European Class 6	mg/kWh	30	30	30	30	40	40	35	35	55	55
	Pressure at flue outlet	Pa	200	200	115	165	122	176	180	193	160	200
Misc.	Nominal supply voltage		230V 1Ph 50Hz									
	Approx. shipping weight	kg	340	340	393	393	502	502	592	592	800	800
	Noise emissions/module @ 1m	Max dB (A)	65	65	61	61	61	61	68	68	68	68

### Dimensions 120-600 models

Dimensions	Reference	120	140	180	225	275	320	390	450	525	600
Width	A	734	734	734	734	812	812	912	912	1161	1161
Height	B	1530	1530	1780	1780	1877	1877	2023	2023	2016	2016
Depth	C	1189	1189	1218	1218	1341	1341	1392	1392	1588	1588
Front clearance	D	500	500	500	500	600	600	700	700	700	700
Top clearance	E	150	150	320	320	263	263	427	427	427	427

**Note:** All dimensions in mm unless otherwise stated.

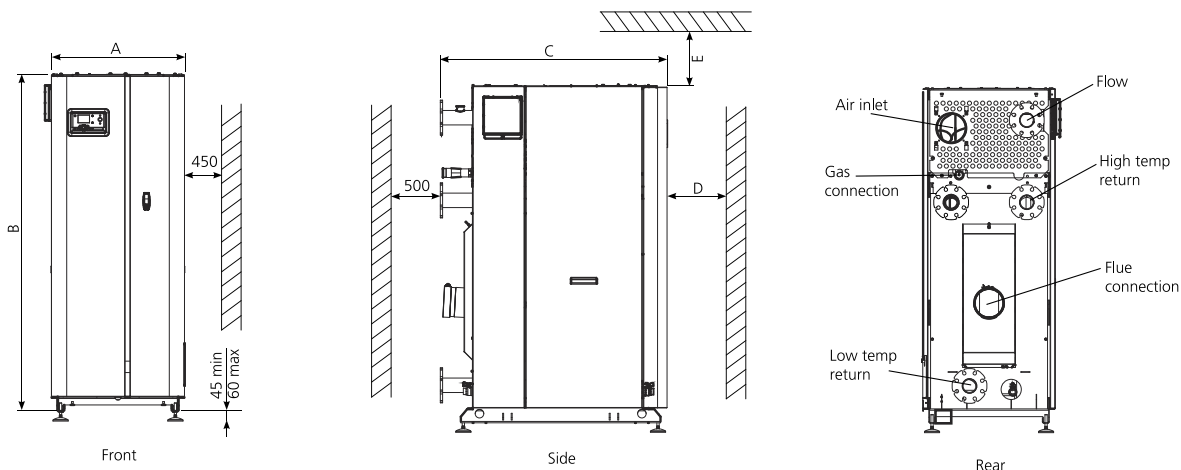

# Purewell Variheat mk2 floor standing cast iron boiler

5 models  
70-180 kW output

Purewell Variheat mk2 is the only ErP compliant cast iron condensing commercial boiler available in the UK. It is the natural replacement for old atmospheric boilers.

## Key benefits:

- > Robust cast iron heat exchanger
- > Proven reliability with 10-year heat exchanger warranty
- > Tolerant of older heating systems
- > Close control and accurate load matching
- > Secondary heat exchanger ensures maximum amount of residual heat from combustion is extracted
- > 6 bar rated heat cell
- > Integral boiler sequence controller for up to 16 boiler modules
- > Suitable for open vented and sealed systems
- > Easy access for servicing with quick to remove front cover hooks
- > Ideal for refurbishments - sits on same footprint as many older atmospheric boilers

## Options:

- > External boiler sequencing cascade controller
- > Room sensors
- > LPB bus communications modules
- > Outside air sensor
- > DHW cylinder sensor kit
- > Pipework header kits
- > Available for use with LPG Air (for Channel Islands)



**47% reduction in  
gas consumption**

The Marlowe Theatre in Canterbury almost halved their gas consumption by upgrading to Purewell Variheat boilers.



Scan to  
read more

# Purewell Variheat mk2

## Technical information

Purewell Variheat mk2 boiler models		Units	PV70c	PV95c	PV110c	PV140c	PV180c
Energy	Building regulations – seasonal efficiency	(%) gross	95.3	95.6	95.8	95.7	94.6
	ErP efficiency rating (modules ≤ 70 kW only)		A	N/A	N/A	N/A	N/A
	Boiler output (non-condensing) mean 70°C – maximum	kW	63.5	86.3	99.8	134.4	172.8
	Boiler output (non-condensing) mean 70°C – minimum	kW	21.2	28.8	33.3	44.8	50.3
	Boiler output (condensing) mean 40°C – maximum	kW	70	95	110	140	180
	Boiler output (condensing) mean 40°C – minimum	kW	23.3	31.67	36.37	46.67	53.0
	Gross boiler input – maximum	kW	72.2	98.4	115	151.3	194.6
	Gross boiler input – minimum	kW	24.1	26.7	38.3	50.4	56.6
	Net boiler input – maximum	kW	65	88.6	103.5	136.3	175.2
	Net boiler input – minimum	kW	21.7	29.6	34.5	45.4	51.0
Water	System design flow rate @ 20°C ΔT rise	l/s	0.8	1.1	1.3	1.7	2.1
	Water side pressure loss @ 20°C ΔT rise	mbar	32	52	72	134	221
	System design flow rate @ 11°C ΔT rise	l/s	1.5	2.1	2.4	3	3.9
	Water side pressure loss @ 11°C ΔT rise	mbar	96	176	244	442	731
	Maximum water pressure	bar g	6	6	6	6	6
Gas	Gas flow rate natural gas (G20) – maximum	m <sup>3</sup> /hr	6.9	9.4	10.9	14.4	18.5
	Maximum gas inlet pressure natural gas (G20)	mbar	25	25	25	25	25
Flue	Flue Gas Flow Rate@ 15°C, 9.5% CO <sub>2</sub>	m <sup>3</sup> /hr	86	117	137	180	232
	Approx. flue gas temperature @ 80/60 (50/30)°C	°C	60 (40)	60 (40)	65 (45)	70 (50)	75 (50)
	Pressure at boiler flue spigot @full load	Pa	100	100	100	100	100
	Dry NO <sub>x</sub> emission (0% excess oxygen, dry air free) European Class 6	mg/kWh	21.3	31.1	39.1	32	37.8
	Nominal flue diameter (I/D)	mm	150	150	150	150	150
Electrics	Electrical supply	230 V 1 Ph 50 Hz					
	Power consumption @maximum	W	94	94	94	207	207
	IEC power outlet power consumption @ maximum	W	460	460	460	460	460
	Start current and run current	Amp	0.54	0.54	0.54	0.6	0.6
Misc.	Approx shipping weight	kg	195	195	195	250	250
	Noise emission @1m and @maximum boiler modulation	Max dB (A)	53	53	53	65	65

## Dimensions

**Note:** All dimensions in mm unless otherwise stated.

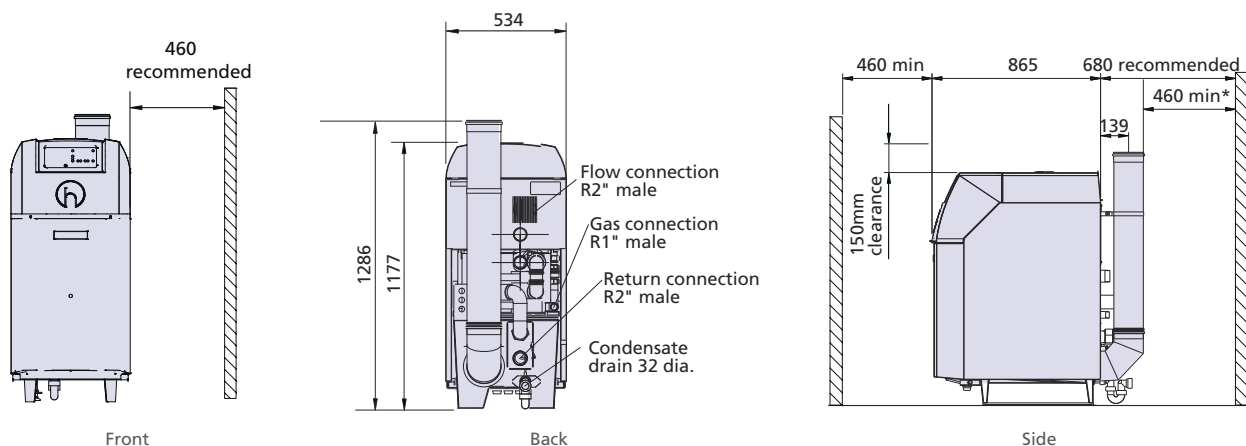

\*Rear clearance required when using Hamworthy pipe kits.

\*If higher flow temperatures are required (up to 85°C maximum) please contact Hamworthy.

# Dorchester DR-SG stainless steel water heater

10 models  
continuous flow  
360-2190 litres/hour

The Dorchester DR-SG is available in 10 power outputs over 3 storage capacities. The range features a full stainless steel tank, heat exchanger and coil offering a durable solution while maximising product life.

## Key benefits:

- > Storage tank, heat exchanger and coil all manufactured from stainless steel
- > Enhanced durability under challenging water conditions
- > NOx under 40 mg/kWh across the range (Class 6)
- > Quick and easy burner access
- > Operated via the popular Siemens LMS Mini controls platform
- > Integrated flue non-return valve
- > Can deliver flow rates to satisfy high demand environments
- > Suitable for natural gas and LPG systems (conversion kit available)

## Why use a stainless steel tank over alternative materials?

- > More resistant to corrosion so maximises service life
- > Able to tolerate low pH water which can be a cause of aggressive corrosion
- > Significantly lighter than other commonly used materials for water heaters\* so aid transportation and handling

\* 200kg lighter than nearest equivalent enamelled steel product



### Enhanced durability with anode protection

The combination of stainless steel tank with an anode within means that the water heater can maintain performance under challenging water conditions.

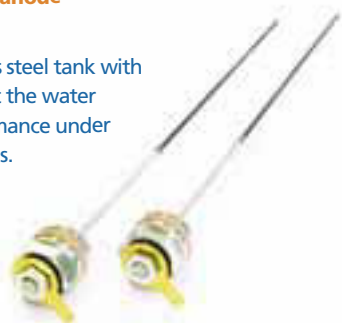



# Dorchester DR-SG

## Technical information

Model:		DR-SG 20-210	DR-SG 25-210	DR-SG 30-210	DR-SG 35-356	DR-SG 50-356	DR-SG 60-356	DR-SG 70-538	DR-SG 80-538	DR-SG 100-538	DR-SG 120-538	
Energy	Max Heat Input (Gross)	kW	20	25	30	35	50	56.6	69.9	80	100	120
	Max Power Output (Net)	kW	21	26.3	31.5	37	53	60	73.4	84	105	126
	Building regulations Part L, EN89 100% efficiency (NCV)	%	105	105	105	106	106	106	106	106	106	106
	Building regulations Part L, EN89 100% efficiency (GCV)	%	94.6	94.6	94.6	95.5	95.5	95.5	95.5	95.5	95.5	95.5
	Standby Loss	kWh/day	1.6	1.6	1.6	1.9	1.9	1.9	3.2	3.2	3.2	3.2
	Building regulations Part L, Maintenance Consumption (EN89)	kWh/day	2.7	2.7	2.7	3.4	3.4	3.4	5.6	5.6	5.6	5.6
	ErP efficiency rating		A	A	A	A	A	A	A	n/a	n/a	n/a
	Water Heater Efficiency (ErP)	%	95.9	91.7	93.5	90.3	92.5	91.4	92.7	91.3	90.8	90
	ErP Load Profile		XXL	XXL	XXL	XXL	XXL	XXL	3XL	3XL	3XL	3XL
Water	Storage Capacity	L	210	210	210	356	356	356	538	538	538	538
	1st 10 mins at ΔT 50°C	l/10'	175	205	220	330	400	435	475	500	550	600
	1st hour at ΔT 50°C	l/60'	450	570	580	630	1100	1210	1500	1700	2000	2300
	Continuous Flow at ΔT 50°C	l/hr	360	450	540	640	910	1090	1280	1460	1820	2190
	Max DHW temperature setpoint	°C	80	80	80	80	80	80	80	80	80	80
	Max operating pressure (open vented)	bar	7	7	7	7	7	7	7	7	7	7
	Max operating pressure (unvented)	bar	6.5	6.5	6.5	6.5	6.5	6.5	6.5	6.5	6.5	6.5
	Heat-up time (mins) 50°C rise		36	29	24	35	24	20	26	23	18	15
	Heat-up time (mins) 55°C rise		40	32	26	39	27	22	29	25	20	17
Gas	Gas Inlet Pressure (Nominal nat gas)	mbar	20	20	20	20	20	20	20	20	20	20
	Gas flow rate (Nominal nat gas)	m³/hr	2.1	2.6	3.2	3.7	5.3	6	7.4	8.5	11	12.7
	Gas Inlet Pressure (Nominal, LPG)	mbar	37	37	37	37	37	37	37	37	37	37
	Gas flow rate (LPG)	m³/hr	0.8	1	1.2	1.4	2	2.4	2.7	3.1	4	4.7
	Gas connection		R 3/4"	R 3/4"	R 3/4"	R 3/4"	R 3/4"	R 3/4"	R 1"	R 1"	R 1"	R 1"
Flues	Max flue gas temperature	°C	100	100	100	100	100	100	100	100	100	100
	Nominal flue gas operating temp	°C	39	55	60	40.3	50.9	51.6	56.8	58.8	59.8	59.3
	Flue Gas Volume @15°C	kg/h	33.1	41.4	49.7	53.3	79.9	95	104.4	118.8	158.4	187.2
	NOx emissions	mg/kWh	29	29	29	32	32	32	39.5	39.5	39.5	39.5
	Pressure at flue outlet	Pa	110	170	200	130	200	200	65	95	155	200
	Air inlet/Flue outlet diameter	mm	80	80	80	100	100	100	130	130	130	130
	Max system length – C type flues	m	20	20	20	20	20	20	20	20	20	20
Electrical	Electrical Supply	V	230 V AC (+10%, -15%) 50Hz									
	Fuse rating	amp	6.3	6.3	6.3	6.3	6.3	6.3	6.3	6.3	6.3	6.3
	Power consumption (maximum)	W	12.7	12.7	12.7	18	18	18	22.5	22.5	22.5	22.5
	Power consumption (standby)	W	3.6	3.6	3.6	3.7	3.7	3.7	4.5	4.5	4.5	4.5
Misc	Sounds Power Level (Noise emissions)	dBA	64	64	64	75	75	75	67	69	74	78
	Number of Anodes		1	1	1	2	2	2	3	3	3	3
	Dry weight	kg	96	96	96	142	142	142	240	240	240	240
	Filled Weight	kg	306	306	306	498	498	498	778	778	778	778
	Height	mm	1802	1802	1802	1874	1874	1874	2028	2028	2028	2028
Diameter (inc insulation)	mm	600	600	600	750	750	750	890	890	890	890	

WATER HEATERS



Scan to read more

The Knaresborough Inn needed a high-efficiency low-temperature hot water (LTHW) heating system from to help minimise energy costs and maintain a comfortable environment for all bedrooms and circulation spaces.

# Dorchester DR-SG

## Technical information

Dorchester DR-SG XX-210

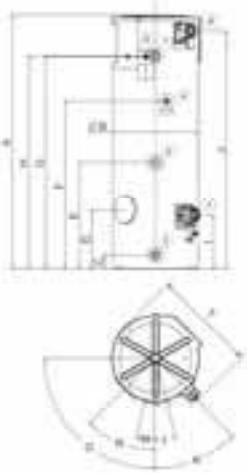

Dorchester DR-SG XX-356

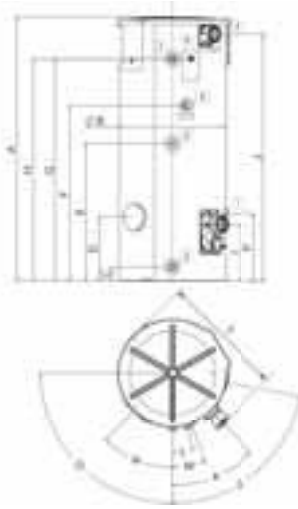

Dorchester DR-SG XX-538

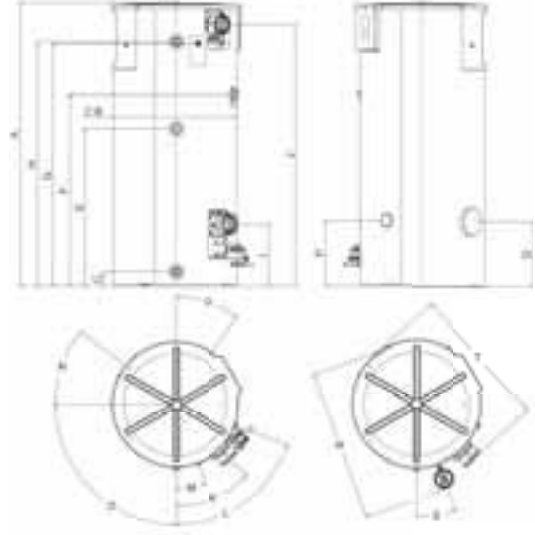

### Connections

Models	Dorchester DR-SG XX-210			Dorchester DR-SG XX-356			Dorchester DR-SG XX-538			
	20	25	30	35	50	60	70	80	100	120
1 Hot water outlet	Rp 1 1/2"			Rp 1 1/2"			Rp 1 1/2"			
2 Loop return	Rp 1 1/2"			Rp 1 1/2"			Rp 1 1/2"			
3 Cold water inlet	Rp 1 1/2"			Rp 1 1/2"			Rp 1 1/2"			
4 T&P valve	Rp 1"			Rp 1 1/4"			Rp 1 1/2"			
5 Gas inlet	R 3/4"			R 3/4"			R 1"			
6 Air inlet	Ø 80			Ø 100			Ø 130			
7 Flue outlet	Ø 80			Ø 100			Ø 130			

### Dimensions

ref	DR-SG XX-210	DR-SG XX-356	DR-SG XX-538
A Overall height	1802	1874	2028
B Diameter	Ø 600	Ø 750	Ø 890
C Height to cold water inlet	100	100	100
D Height to inspection hatch	419	454	467
E Height to secondary return	759	980	1129
F Height to T&P valve connection	1193	1248	1373
G Height to gas connection	1508	1580	1735
H Height to hot water outlet	1514	1579	1748
I Height to flue outlet	380	402	442
J Height to air inlet	1691	1752	1871
K Angle position of flue outlet	45°	45°	45°
L Angle position of T&P valve fitting	13°	15°	70°
M Angle position of gas connection	12.9°	20°	20°
N Angle position of inspection hatch	45°	45°	38°
O Angle position of HMI	90°	90°	90°
P Height of lower anode fitting	NA	478	470
Q Angle position of lower anode fitting	NA	80°	35°
R Overall width with LPG conversion kit	NA	NA	639
S Angle position of gas connection with LPG conversion kit	NA	NA	20°
T Max installed width	699	884	1020
U Height to condensate trap outlet	233	230	151

### Clearances

ALL MODELS	DR-SG
Clearance – front (service)	mm Min 500
Clearance – sides	mm 500
Clearance – rear	mm 500
Clearance – top	mm 175

# Dorchester DR-FC Evo water heater

7 models  
continuous outputs  
600-2400 litres/hour

Featuring modulating burners and condensing operation, the Dorchester DR-FC Evo provides a high efficiency domestic hot water solution which can be sized to suit many applications.

## Key benefits:

- > Down firing burner
- > Multiple temperature settings to enhance condensing performance
- > Exceeds Part L minimum requirements
- > Electrical anode for corrosion protection
- > Whisper quiet <45 dB(A)
- > Low NOX
- > Up to 98% seasonal efficiency
- > Inspection & cleanout door for easy maintenance
- > 7 day programmable timeclock
- > 2 year warranty

## Options:

- > Natural gas or LPG
- > Unvented supply kit
- > Horizontal or vertical flue terminal kit
- > Top-to-bottom pump recirculation kit
- > Remote monitoring unit



WATER HEATERS



The Abbey Hill Academy in Stockton-on-Tees benefited from the Government's Condition Improvement Fund to refurbish their old school boilers and water heaters.



## Improved scale tolerance

This condensing water heater has a down firing pre-mix modulating burner that reduces the risk of scale build up impacting on heat transfer.

# Dorchester DR-FC Evo

## Technical information

	Model	Unit	DR-FC Evo 25	DR-FC Evo 30	DR-FC Evo 45	DR-FC Evo 60	DR-FC Evo 80	DR-FC Evo 95	DR-FC Evo 120
Energy	Building regulations thermal efficiency gross	%	96	98	96	95	97	95	95
	ErP efficiency rating		A	A	A	A	N/A	N/A	N/A
	Input, gross maximum (output – maximum)	kW	31.6 (30.5)	32.6 (32.0)	51.2 (49.3)	61.2 (59.3)	85.0 (82.6)	103.4 (98.7)	126.3 (119.4)
	Heating-up time, $\Delta T = 44^{\circ}\text{C}$	min.	23	37	24	20	19	16	13
	Heating-up time, $\Delta T = 50^{\circ}\text{C}$	min.	26	42	27	23	21	18	15
	Heating-up time, $\Delta T = 55^{\circ}\text{C}$	min.	29	46	30	25	23	20	16
Water	Continuous output with $44^{\circ}\text{C } \Delta T$ (1st hour output)	l/h (l)	600 (730)	630 (870)	970 (1300)	1200 (1500)	1700 (1900)	2000 (2200)	2400 (2600)
	Continuous output with $50^{\circ}\text{C } \Delta T$ (1st hour output)	l/h (l)	530 (630)	560 (730)	850 (1100)	1100 (1300)	1500 (1700)	1700 (1900)	2100 (2300)
	Continuous output with $55^{\circ}\text{C } \Delta T$ (1st hour output)	l/h (l)	480 (560)	510 (640)	780 (930)	930 (1100)	1300 (1500)	1600 (1700)	1900 (2000)
	Storage capacity	litres	227	386	386	386	504	504	504
	Maximum operating water pressure – open vented (unvented)	bar	8 (5.3)	8 (5.3)	8 (5.3)	8 (5.3)	8 (5.3)	8 (5.3)	8 (5.3)
	Expansion relief valve setting - unvented kit	bar	6	6	6	6	6	6	6
Gas	Gas inlet pressure – minimum/nominal/maximum	mbar	17.5 min / 20.0 nom / 25.0 max						
	Gas flow rate – maximum @ 1013.25 mbar and $15^{\circ}\text{C}$	$\text{m}^3/\text{h}$	3.1	3.2	5.0	6.0	8.3	10.1	12.3
Flue	Approx. flue gas volume @ $15^{\circ}\text{C}$ , 9.8% $\text{CO}_2$ , N.T.P	$\text{m}^3/\text{h}$	37.3	38.5	60.2	72.3	103.1	125.5	152.8
	Flue gas temperature - maximum	$^{\circ}\text{C}$	45	50	60	65	50	55	60
	NOx emission (0% excess oxygen, dry air free) European Class 5	mg/kWh	24	32	36	37	34	36	36
	Pressure at flue outlet (B23) with no pressure at air inlet	Pa	52	62	133	173	88	126	180
Misc.	Nominal supply voltage		230V 1Ph 50Hz						
	Weight – empty (filled with water)	kg	196 (423)	239 (625)	239 (625)	239 (625)	405 (909)	405 (909)	405 (909)
	Approx. shipping weight	kg	215	260	260	260	426	426	426
	Noise emissions @2m from flue terminal	Max dB (A)	<45	<45	<45	<45	<45	<45	<45

# Dorchester DR-FC Evo

## Technical information

### Dimensions

Dimension	Reference	DR-FC Evo 25	DR-FC Evo 30	DR-FC Evo 45	DR-FC Evo 60	DR-FC Evo 80	DR-FC Evo 95	DR-FC Evo 120
Height	A	1485	2015	2015	2015	2060	2060	2060
Diameter	B	705	705	705	705	850	850	850
Depth	C	925	925	925	925	1000	1000	1000
Width	D	850	850	850	850	900	900	900

**Note:** All dimensions in mm unless otherwise stated.

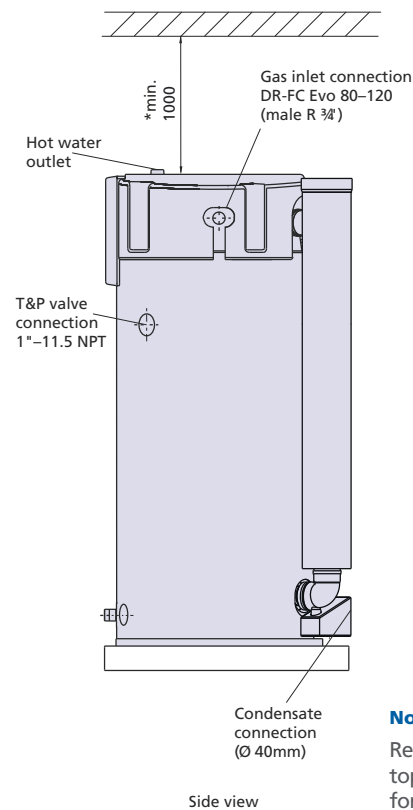
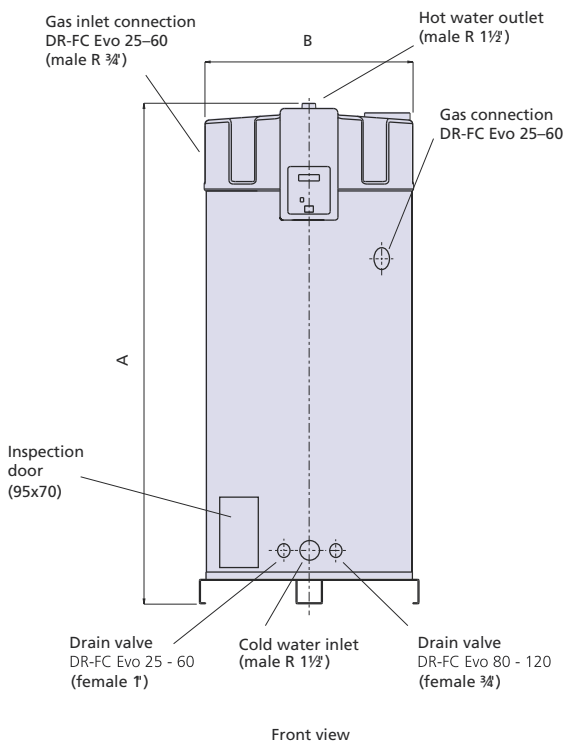
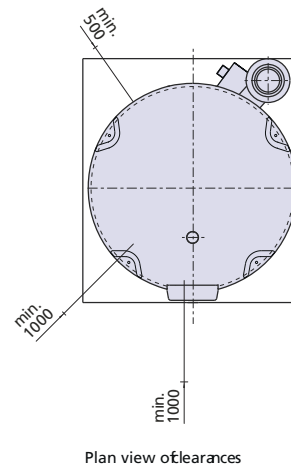
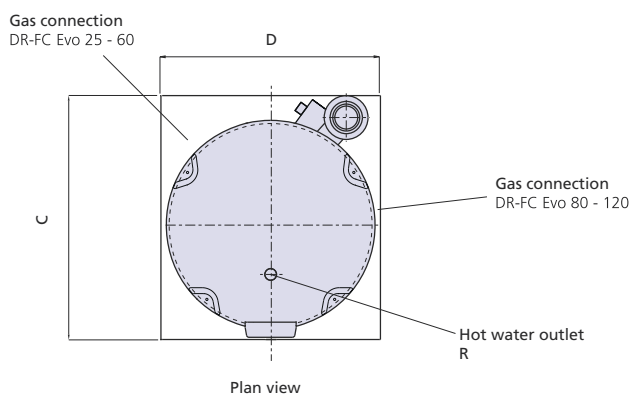

**Note:** Recommended 1000mm top clearance is required for removal of anodes.

# Dorchester DR-CC condensing water heater

2 models from  
228-233 litres/hour

A compact, condensing unit with integrated simple to use controls. Its size and flexible flue options make it suited to small to medium sized commercial applications.

## Key benefits:

- > Fits through a standard doorway
- > Heat exchanger design and burner location distributes heat evenly
- > Electrical anode for corrosion protection
- > Easy access for service and maintenance
- > Low NOX
- > Minimal clearances
- > Flexible flue options

## Options:

- > Natural gas or LPG
- > Unvented supply kit
- > Horizontal or vertical flue terminal kit



## Even heat distribution

A 'cold zone' heat exchanger design with the coil located in the middle of the unit, gives a greater surface area for more transfer of heat as well as even heat distribution inside the tank, and reduces the likelihood of stratification.

# Dorchester DR-CC condensing water heater technical information

Dorchester DR-CC model		Units	DR-CC 12-160	DR-CC 12-200
Water	Continuous output with 44°C ΔT	l/h	228	233
	1st hour output with 44°C ΔT	l	360	470
	Continuous output with 50°C ΔT	l/h	201	205
	1st hour output with 50°C ΔT	l	310	410
	Continuous output with 56°C ΔT	l/h	180	183
	1st hour output with 56°C ΔT	l	270	360
	Storage capacity	litres	162	202
	Maximum working pressure	bar	8	8
Energy	ErP load profile	-	XL	XL
	Building Regulations thermal efficiency gross	%	96	98
	ErP efficiency rating	-	A	A
	Heating-up time, ΔT = 44°C	min.	27	41
	Heating-up time, ΔT = 50°C	min.	31	47
	Heating-up time, ΔT = 56°C	min.	34	52
Nat Gas	Standby losses	kW/24h	2.16	2.3
	Input, gross – maximum	kW	12.1	12.1
	Input, net – maximum	kW	10.9	10.9
	Output – maximum	kW	11.7	11.9
	Gas inlet pressure - nominal	mbar	20	20
Gas flow rate – maximum @1013.25 mbar and 15°C		m³/h	1.2	1.2

## Dimensions

Reference	Dimension	DR-CC 12-160	DR-CC 12-200
A	Total Height	1270	1545
D	Width	560	560
E	Depth	805	805

**Note:** All dimensions in mm unless otherwise stated.

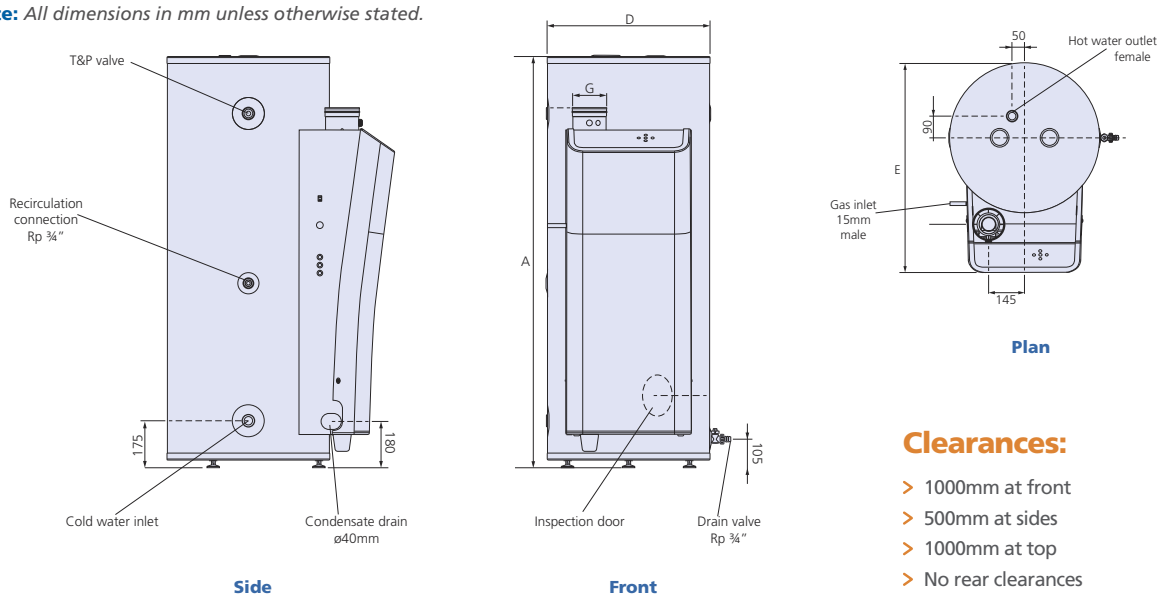

### Clearances:

- > 1000mm at front
- > 500mm at sides
- > 1000mm at top
- > No rear clearances

# Powerstock glass lined calorifier

7 models  
continuous outputs  
501-1635 litres/hour

Offering a flexible approach to indirect heating and storage, Powerstock calorifiers can be easily coupled to any heating boiler or renewable energy source to provide highly efficient domestic hot water.

## Key benefits:

- > Twin coils connect to two energy sources or can be linked together for even better performance
- > Safe storage of hot water
- > Integration with renewable energy products such as solar
- > Magnesium anode corrosion protection for longer life
- > Adaptable to match load demand
- > Inspection & clean out door for easy maintenance
- > 2 year warranty

## Options:

- > Unvented supply kit
- > Top-to-bottom pump recirculation kit
- > Electrical anode protection
- > Electric immersion heater kits with ratings of 4kW or 9kW



## Easy access for service & maintenance

An easily accessible clean out door as well as all serviceable parts being located at the front of the unit make the DR-CC easy to service and maintain. This allows for minimal side and no rear clearances so the unit can be easily installed in tight plantrooms.



## Twin coils

All but the two smallest models have twin coil arrangements which can be connected to two heat sources such as a heating boiler and a solar thermal system.

Alternatively the coils can be connected in series to create an extended surface area single coil.



# Powerstock glass lined calorifier

## Technical information

	Units	PS160	PS200	P300	PS400	PS500	PS750	PS1000	
General data	Storage capacity	l	157	196	299	382	474	750	972
	ErP efficiency rating		B	C	C	C	C	C	C
	Top coil surface area (volume)	m <sup>2</sup> (l)	N/A	N/A	0/8 (6.6)	1.05 (7.0)	1.3 (8.9)	1.17 (8.2)	1.12 (7.9)
	Bottom coil surface area (volume)	m <sup>2</sup> (l)	0.75 (4.9)	0.95 (6.2)	1.55 (10.4)	1.8 (12.2)	1.9 (12.2)	1.93 (13.5)	2.45 (17.1)
	Maximum operating pressure – primary coil (secondary storage)	bar	10 (10)	10 (10)	10 (10)	10 (10)	10 (10)	10 (10)	10 (10)
	Maximum operating temperature – primary coil (secondary storage)	°C	110 (70)	110 (70)	110 (70)	110 (70)	110 (70)	110 (70)	110 (70)
	Standby losses	kW/24hr	1.34	1.63	1.99	2.06	2.4	3.1	3.41
Bottom coil only in operation	Continuous output – ΔT = 50°C	l/h	501	600	816	976	1109	1062	1281
	Heat input	kW	29.2	35.6	48.4	57.9	65.7	63.0	76.0
	10 min peak output – ΔT = 50°C	l	250	362	448	615	771	1100	1197
	Recovery time	min.	20	20	22	24	26	42	46
Top & bottom coil connected in series	Continuous output – ΔT = 50°C	l/h	N/A	N/A	1032	1285	1549	1432	1635
	Heat input	kW	N/A	N/A	61.2	76.2	91.8	85.0	97.0
	10 min peak output – ΔT = 50°C	l	N/A	N/A	567	889	1077	1319	1483
	Recovery time	min.	N/A	N/A	17	18	18	31	36

\* Continuous outputs in header are @ 44°C ΔT

## Dimensions

Dimension	Reference	PS160	PS200	PS300	PS400	PS500	PS750	PS1000
Diameter	A	540	540	600	700	700	950	1050
Height	B	1184	1445	1794	1591	1921	2030	2030
Hot water outlet	C	R¾"	R¾"	R1"	R1"	R1"	R1¼"	R1¼"
Cold water feed	D	R¾"	R¾"	R1"	R1"	R1"	R1¼"	R1¼"

**Note:** All dimensions in mm unless otherwise stated.

# Powerstock hot water storage tank

4 models  
storage capacity  
300-981 litres/hour

Easily coupled to any direct or indirect water heater system to supplement storage volumes to suit large demand applications.

## Key benefits:

- > Safe storage of hot water
- > Can be easily coupled to any direct or indirect fired hot water systems
- > Supplements hot water storage volumes to suit large demand applications
- > Increases system security
- > Magnesium anode corrosion protection for long life
- > Inspection & clean out door for easy maintenance
- > 2 year warranty

## Options:

- > Unvented supply kit
- > Top-to-bottom pump recirculation kit
- > Electrical anode protection
- > Electric immersion heater kits with ratings of 4kW or 9kW



## Increase system security

Locations with substantial and continuous hot water demands can use Powerstock storage tanks to increase the security of their DHW system.

# Powerstock hot water storage tank

## Technical information

		Units	ST300	ST500	ST750	ST1000
General data	ErP class		C	C	C	C
	Storage capacity	l	300	478	750	981
	Maximum operating pressure	bar	10	10	10	10
	Maximum operating temperature	°C	95	95	95	95
	Weight – empty (filled with water)	kg	87 (387)	111 (613)	217 (967)	283 (1264)
	Standby losses	kW/24hr	2.4	3.12	3.6	4.8

### Dimensions

Dimension	Reference	ST300	ST500	ST750	ST1000
Diameter	A	600	700	950	1050
Height	B	1794	1921	2030	2030
Clearance	C	600	600	600	700

**Note:** All dimensions in mm unless otherwise stated.

#### ST300 & ST500

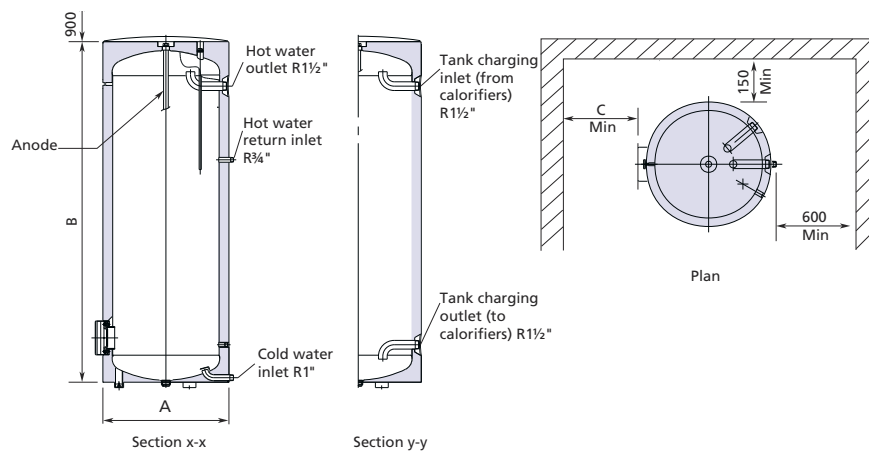

#### ST750 & ST1000

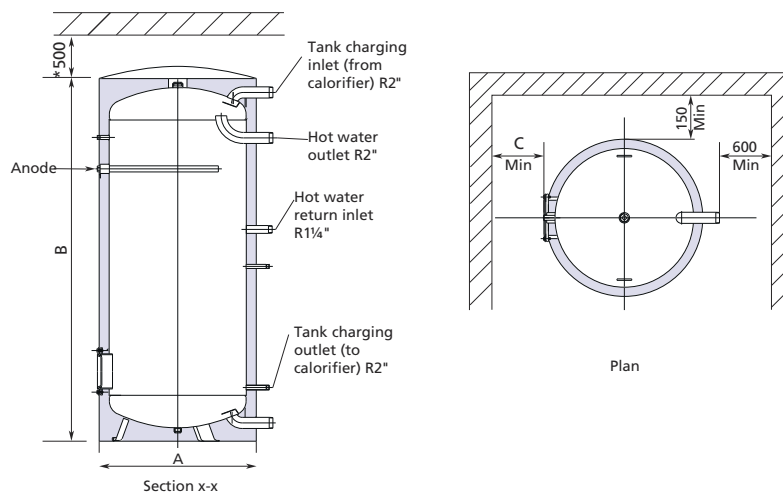

# Halstock stainless steel calorifier

9 models  
continuous outputs  
390-2106 litres/hour

Simple and easy to maintain, the highly durable stainless steel Halstock comes with a 5-year cylinder guarantee.

## Key benefits:

- > Single and twin coil options for improved performance or connection to dual heat sources
- > Corrosion-resistant stainless steel tank
- > Quick heat recovery to match your hot water demands
- > Low heat loss for maximum economy
- > No sacrificial anode - low maintenance
- > Can be installed wherever convenient - no flues needed
- > Fire retardant CFC/HCFC-free insulation reduces heat loss
- > 5 year warranty

## Options:

- > Open vented or unvented variants
- > De-stratification pump kit (factory fitted)
- > Levelling feet (400L + models)

## No anodes required

- > Halstock calorifiers are constructed using high quality duplex stainless steel meaning there is no requirement for additional corrosion protection anodes. This results in easier maintenance and lower life costs.



## Dual heat sources

All but the two smallest models have twin coil arrangements which can be connected to two heat sources such as a heating boiler and a solar thermal system. Alternatively the coils can be connected in series to create an extended surface area single coil.

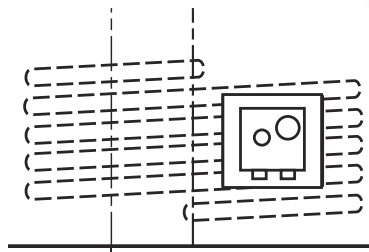

# Halstock stainless steel calorifier

## Technical information

	Halstock model	Units	HS305UV*	HS400 / HS400UV*	HS5002CO / HS500UV2CO*	HS8102CO / HS810UV2CO*	HS9652CO / HS965UV2CO*
Energy	Lower coil output	kW	20	27	67.5	67.5	81
	Upper coil output	kW	N/A	N/A	27	27	27
	ErP efficiency rating	-	C	C	C	Compliant	Compliant
	Coil max operating temperature/ pressure	°C	100 (3)	100 (3)	100 (3)	100 (3)	100 (3)
	Heat up time @50°C ΔT, lower coil only	min	54	53	26	42	42
	Recovery time 70% @50°C ΔT, combined coils	min	38	36	13	21	22
	10 min peak output @50°C ΔT	litres	361	481	770	1080	1274
	Standby losses	kW/24hr	1.77	2.35	2.74	3.29	3.43
Water	Capacity, nominal (Capacity with coil)	litres	305 (298)	400 (396)	500 (496)	810 (803)	965 (958)
	Continuous output @44°C ΔT	l/h	390	527	1843	1843	2106
	Continuous output @50°C ΔT	l/h	344	464	1622	1622	1853
	Maximum working pressure, tank	bar	6	6	6	6	6
	Hydraulic test pressure	bar	9	9	9	9	9
Misc.	Expansion vessel size	litres	24	35	35	50	80
	Weight empty (full)	kg	75 (379)	105 (505)	115 (515)	140 (950)	180 (1145)
	Immersion heater	ph	1ph	3ph/1ph	3ph/1ph	3ph	3ph

### Dimensions

Dimensions	Reference	HS305UV*	HS400/ HS400UV*	HS5002CO / HS500UV2CO*	HS8102CO / HS810UV2CO*	HS9652CO / HS965UV2CO*
Tank diameter	A	570	750	750	1080	1080
Tank height	B	2028	1435	1715	1604	1850
Cold inlet	C	182	286	286	341	341
2nd return	D	610	234	234	341	341
Bottom coil centres	E	262.5	225	495	315	405

**Note:** All dimensions in mm unless otherwise stated. \*Supplied with unvented kit

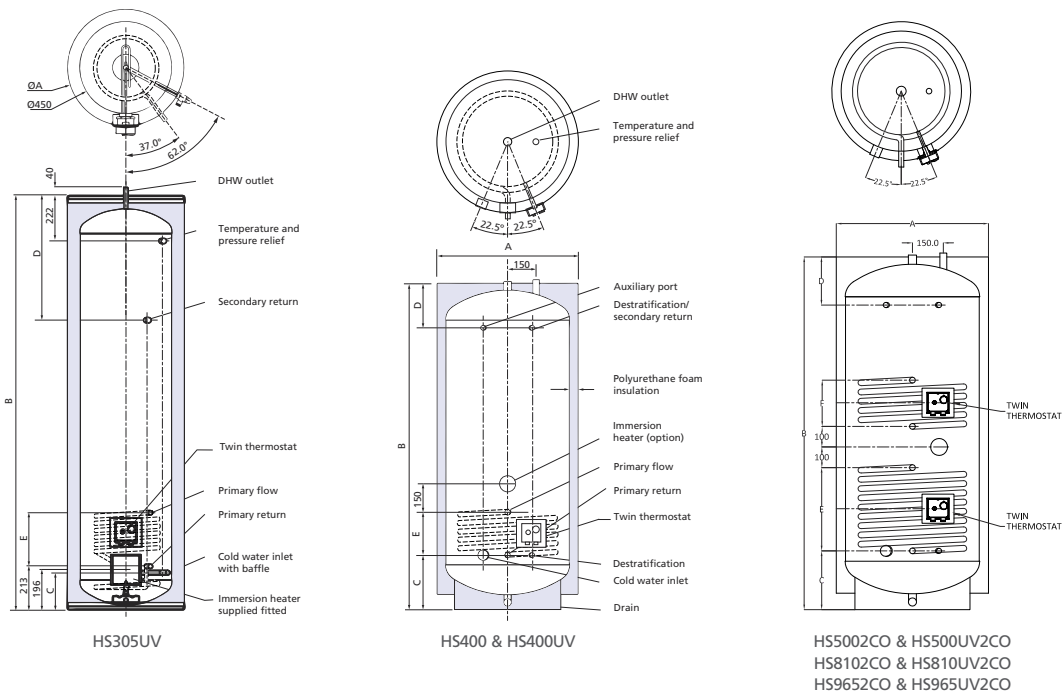

# Halstock hot water storage tank

**5 models  
storage capacity  
300-965 litres**

Simple and easy to maintain, the highly durable stainless steel Halstock comes with a 5-year cylinder guarantee.

## Key benefits:

- > Can be easily coupled to any direct fired water heaters or indirect fired calorifiers in a commercial hot water heater system
- > Supplements hot water storage volumes to suit large buildings with large and peak hot water demand
- > Minimal heat loss for maximum economy thanks to layer of CFC-free polyurethane tank insulation under protective plastisol cladding
- > 5 year warranty

## Options:

- > Immersion heaters (6, 9 or 12kW)



### Increase System security

Locations with substantial and continuous hot water demands can use Halstock storage tanks to increase the security of their DHW system.

# Halstock hot water storage tank

## Technical information

Parameter	Units	HB300	HB400	HB500	HB810	HB965
Capacity nominal	litres	300	400	500	810	965
Max operating temperature	°C	100	100	100	100	100
Max operating pressure	bar	6	6	6	6	6
Standby loss	kW/hr/24hr	1.77	2.35	2.74	3.29	3.43
ErP category		C	C	C	Compliant	Compliant
Hydraulic test pressure	bar	9	9	9	9	9
Immersion heater option power	kW	3	6,9 or 12	6,9 or 12	6,9 or 12	6,9 or 12
Phase		1ph	1ph or 3ph	1ph or 3ph	3ph	3ph
Weight empty	kg	55	80	95	155	175
Weight full	kg	355	480	595	965	1140

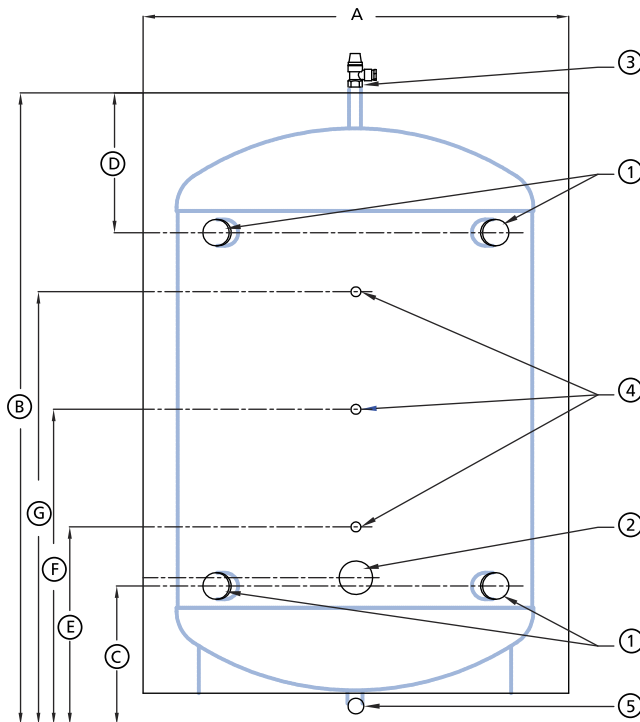

### Dimensions

Heating buffers (Stainless steel)													
Models	Dimensions mm								Connections (BSP female)				
	A	B	C	D	E	F	G	Insulation	1	2	3	4	5
	Dia	Height	Bottom inlet	Top inlet	Bottom sensor pocket	Middle Sensor pocket	Top sensor pocket		Top/Bottom inlet	Immersion	T&P	Sensor pockets	Drain
<b>300</b>	570	2028	185	222	355	1029	1653	60	28mm stub	1¼"	¾"	½"	None
<b>400</b>	750	1430	295	254	445	736	1027	50	2"	2¼"	¾"	½"	1"
<b>500</b>	750	1715	295	254	445	878	1312	50	2"	2¼"	¾"	½"	1"
<b>810</b>	1080	1604	352	355	502	800.5	1098	90	2"	2¼"	¾"	½"	1"
<b>965</b>	1080	1850	352	355	502	923	1345	90	2"	2¼"	¾"	½"	1"

**Note:** All dimensions in mm unless otherwise stated.

# Hydraulic system separation

Hydraulic separation is vital when installing new condensing boilers on old systems. Protecting the new system from dirt and debris will prolong the life of the new boiler.

## Plate heat exchangers

- > Available with Stratton mk3 boilers
- > Used to separate systems, allowing two circuits to operate independently
- > Ensures boilers can operate under optimum system conditions
- > Braze plate heat exchangers offer compact, resilient, gasket-free design
- > Stainless 316 channel plates with copper sealing
- > Exchangers AHRI certified
- > Low maintenance

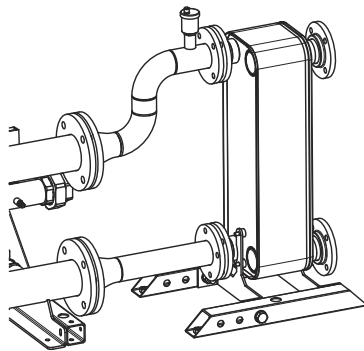

**7 models**  
**60-900 kW capacity**

## Low loss headers

- > Available with Stratton mk3, Wessex Modumax mk3 and Upton boilers
- > Used to separate systems, allowing two circuits to operate independently
- > Ensures boilers can operate under optimum system conditions
- > Welded steel construction





# Merley sequence controller

A common control platform that can be used with the Wessex ModuMax mk3, Stratton mk3, Varmax, Upton and Purewell Variheat mk2 condensing boilers.

## Key benefits:

- > Boiler sequence controller for up to 15 modules in cascade or unison mode
- > Energy saving functionality
- > Reduces carbon emissions by accurately matching load
- > Lead boiler rotation and load sharing
- > Intelligent self-learning control
- > ersatile control strategies
- > Heating zone and DHW management
- > 2 year warranty

## Options:

- > Loose kit controller
- > External air sensor
- > Choice of room sensors
- > Hard wired controls
- > Domestic hot water sensor
- > Strap on flow temperature sensor



## Dimensions

Display unit dimensions

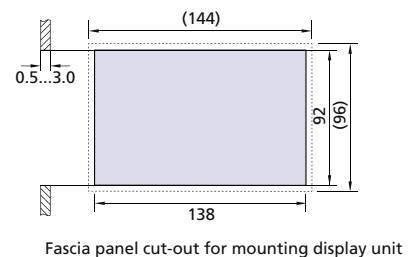
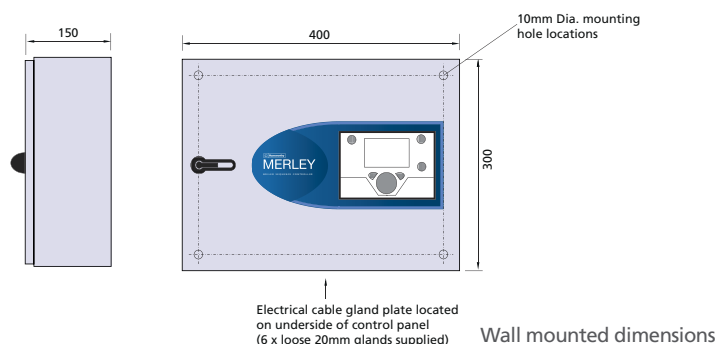
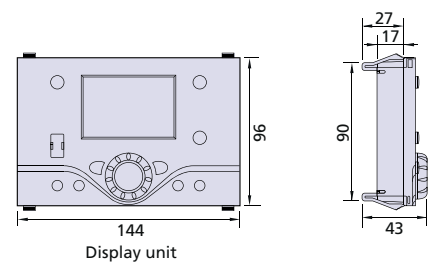
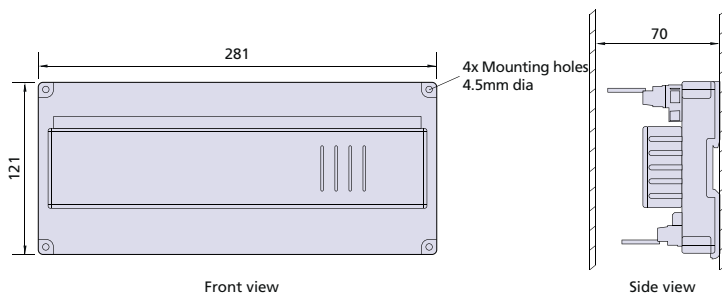

Loose kit dimensions

**Note:** All dimensions in mm unless otherwise stated.

# Horton dosing pot

4 models  
capacities of  
3.5-15 litres

Facilitates safe insertion of liquid chemicals into a sealed heating system.

## Key benefits:

- > Carbon steel pipe body and tundish with brass valves
- > Simple and safe to operate without needing to drain down the system
- > Easy to isolate and flush clean
- > Working pressure up to 14 bar
- > 2 year warranty

## Technical data

Horton product code	Installed boiler output (kW)	Maximum system volume (litres)
HN-3.5	0-250	0-2499
HN-5	250-500	2,500-4,999
HN-10	500-1000	5,000-9,999
HN-15	1,000 and above	10,000 and above

## Dimensions

Dimension	Reference	HN-3.5	HN-5	HN-10	HN-15
Overall width	A	265	265	315	315
Diameter	B	166	168	219	219
Body height	C	186	258	293	446

Note: All dimensions in mm.

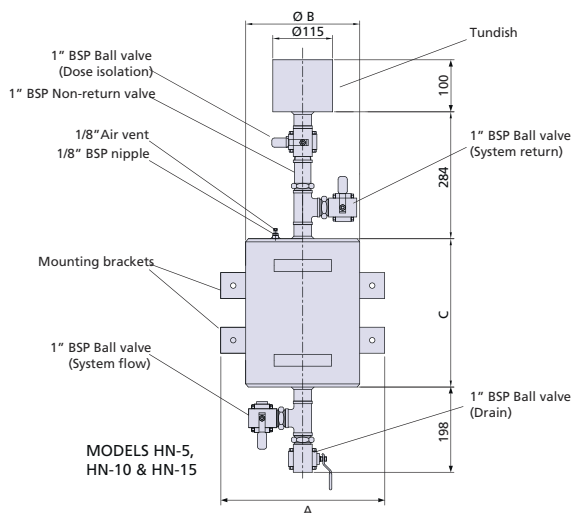
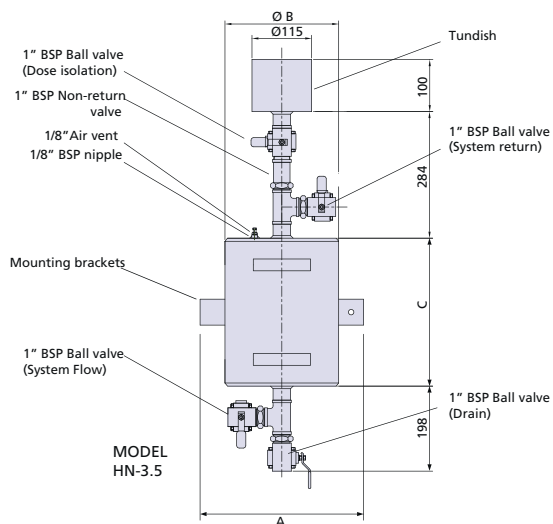

# Clenston air and dirt separator

7 models  
DN50-DN200  
pipe sizes

Air and dirt separator for the removal of dissolved gases and dirt particles from heating systems.

Air collects in the air chamber before being removed by the high capacity automatic air vent (AAV). Dirt and sludge are removed via a ball valve at the bottom of the unit.

## Key benefits:

- > Combines the removal of both air and dirt in a single unit
- > Protects boilers and helps prevent pump failure, energy loss and corrosion
- > Carbon steel pipe
- > Stainless steel concentrator
- > Flanged to BS4504 PN16
- > Brass automatic air vent
- > 1" BSP flushing valve
- > Supplied with gasket and bolts for system mounting
- > Working pressure up to 10 bar
- > 2 year warranty



## Technical data

Clenston product code	Nominal bore (mm)	Pipe connection	Dry weight (kg)	Volume flow rate*		Optimum boiler power* (kW)		
				(m <sup>3</sup> /hr)	(l/s)	@11°C ΔT	@20°C ΔT	@30°C ΔT
CL-50	50	DN50-PN16	15	12.2	3.39	156	283	425
CL-65	65	DN65-PN16	16	20.4	5.67	261	474	711
CL-80	80	DN80-PN16	29	28.2	7.83	360	655	982
CL-100	100	DN100-PN16	31	47.6	13.22	608	1105	1658
CL-125	125	DN125-PN16	39	72.3	20.08	923	1679	2518
CL-150	150	DN150-PN16	46	103.3	28.69	1319	2399	3598
CL-200	200	DN200-PN16	62	174.3	48.42	2226	4048	6071

## Dimensions

Dimension	Ref.	CL-50	CL-65	CL-80	CL-100	CL-125	CL-150	CL-200
Diameter	A	165	165	219	219	273	324	407
Width	B	350	350	460	460	630	630	780
Height	C	583	583	733	733	1003	1003	1083

**Note:** All dimensions in mm unless otherwise stated.

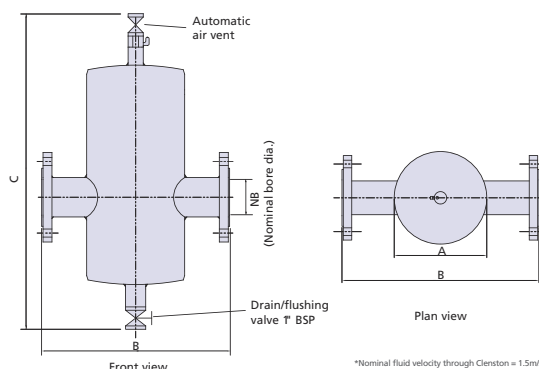

# Burstock expansion vessel

10 models  
capacities of  
25-1000 litres

A floor standing expansion vessels for use with sealed heating and hot water systems.

Burstock expansion vessels are designed to complement pressurisation units and ensure design pressures are maintained. Suitable for use in sealed DHW systems, sealed heating circuits and sealed glycol based solar circuits.

## Key benefits:

- > Nitrogen pre-charge for extended service period
- > Accommodates system water due to expansion in sealed heating and hot water circuits
- > Greater flexibility with a maximum operating temperature of 70°C
- > 2 year warranty



### Nitrogen pre-charge

Burstock expansion vessels are pre-charged with nitrogen which has larger molecules than air resulting in less permeation through the diaphragm so extending the time between pressure top ups. Vessels are pre-charged to 1.7 bar for heating circuits and 3.5 bar for DHW circuits.



### Often bought with Chesil pressurisation unit

A sealed system, created using a pressurisation unit, will require a matched expansion vessel to deal with the expansion and contraction of system water.



# Burstock expansion vessel

## Technical data

Model	Capacity litres	Connection size (inches)	Max. pressure (bar)	Shipping weight (kg)	Pre-charge pressure (bar)
PV25W	25	G 3/4"	10	5	3.5
PV25W kit with wall bracket	25	G 3/4"	10	5	3.5
PV60W	60	G 1"	10	14	3.5
PV60W 1.7bar	60	G 1"	10	14	1.7
PV80W	80	G 1"	10	16	3.5
PV80W 1.7bar	80	G 1"	10	16	1.7
PV100W	100	G 1"	10	19	3.5
PV100W 1.7bar	100	G 1"	10	19	1.7
PV200W**	200	G 1 1/4"	10	40	1.7
PV300W**	300	G 1 1/4"	10	54	1.7
PV400W**	400	G 1 1/4"	10	70	1.7
PV500W**	500	G 1 1/4"	10	79	1.7
PV800W**	800	G 1 1/2"	10	195	1.7
PV1000W**	1000	G 1 1/2"	10	228	1.7

\*\*3.5 bar pre-charge available on request

### Dimensions

Dimension	Reference	PV25W	PV60W	PV80W	PV100W	PV200W	PV300W	PV400W	PV500W	PV800W	PV1000W
Diameter	A	280	409	480	480	634	634	740	740	740	740
Height	B	499	734	729	834	967	1267	1245	1475	2325	2604

**Note:** All dimensions in mm unless otherwise stated.

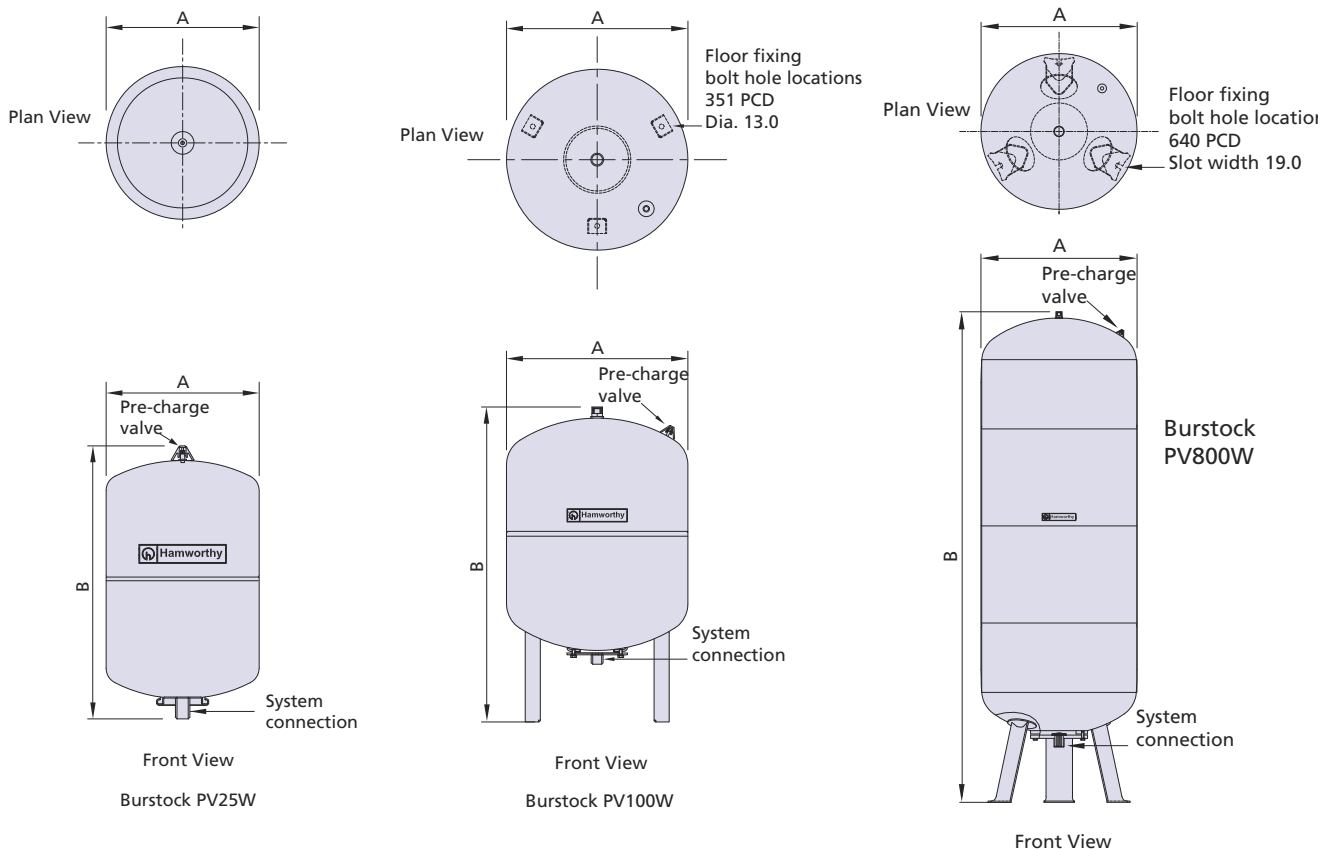

# Chesil mk2 pressurisation unit

5 models  
single/twin pump

Wall hung and floor standing pumped pressurisation units for sealed heating systems.

A pressurisation unit removes the need for cold water header tanks and associated pipe work, or eliminates reliance on mains pressure to provide the system head.

## Key benefits:

- > Compact design saves space
- > Choice of configurations
- > Increases security of heating system
- > Electronic controls
- > BMS compatible for system integration
- > Easy access for operation and settings
- > Reduces installation costs
- > 2 year warranty

## Options:

- > Floor standing or wall hung
- > Single or twin pumps
- > Expansion vessels

Chesil mk2 Pressurisation Unit Type		Chesil mk2 SW	Chesil mk2 SF	Chesil mk2 TW	Chesil mk2 TF	Chesil mk2 TFHP	
UIN		241437	241438	241439	241440	241441	
Configuration		Wall Mounted	Floor Standing	Wall Mounted	Floor Standing	Floor Standing	
Pump		Single	Single	Twin	Twin	Twin	
Controls		Electric	Electric	Electric	Electric	Electric	
GENERAL DATA	Weight (empty)	kg	23.5	25	40	40	41
	Weight (full)	kg	30.5	35	49	50	51
	Maximum cold fill pressure	bar	3	3	3	3	6
	Minimum cold fill pressure	bar	1	1	1	1	3
	Maximum water flow rate	l/min	35	35	35	35	50
	Maximum water flow rate @ max cold fill pressure	l/min	12	12	12	12	28
	Noise level	dBA	<70	<70	<70	<70	<70
ELECTRICAL	Electrical supply		230V AC 50Hz 1Ph	230V AC 50Hz 1Ph	230V AC 50Hz 1Ph	230V AC 50Hz 1Ph	230V AC 50Hz 1Ph
	Pressure transducer contact rating		4-20ma	4-20ma	4-20ma	4-20ma	4-20ma
	Volt free contact rating		6a/240v	6a/240v	6a/240v	6a/240v	6a/240v
	Start current (per pump motor)	Amps	2.6	2.6	2.6	2.6	3.6
	Run current (per pump motor)	Amps	2.6	2.6	2.6	2.6	3.6
FACTORY SETTINGS	Cold fill pressure	bar	2.5	2.5	2.5	2.5	5
	Low pressure setting	bar	0.7	0.7	0.7	0.7	0.7
	High pressure setting	bar	4	4	4	4	7
	Expansion vessel charge pressure	bar	1.7	1.7	1.7	1.7	1.7
SYSTEM PARAMETERS FOR FACTORY SETTINGS	Maximum water flow temperature	°C	80	80	80	80	80
	Maximum static height	m	40.5	40.5	40.5	40.5	62
	Minimum system operating pressure	bar	0.7	0.7	0.7	0.7	1
	Maximum system operating pressure	bar	4	4	4	4	7
	Nominal pressure differential	bar	0.3	0.3	0.3	0.3	0.3
DIMENSIONS	Height	mm	580	800	680	800	800
	Width	mm	570	500	670	500	500
	Depth	mm	300	300	315	350	350
CONNECTIONS	Mains cold water inlet	inch	1/2	1/2	1/2	1/2	1/2
	Overflow (polythene pipe) diameter	mm	20	20	20	20	20
	System connection compression fitting, diameter	mm	15	15	15	15	15

# Tyneham buffer tanks



## Technical features and performance capabilities

Features	Tank Models					
	100	200	500 0F*	500 3F*	900 2F*	1500 2F*
Useful capacity (L)	95	195	517	517	904	1425
Passage width (mm)	N/A	N/A	680	680	795	1015
Min. room height for installation (mm)	N/A	N/A		2100	2100	2415
Tilting dimension (mm)(1)	N/A	N/A	1980	1980	2240	2270
Empty tank weight (kg)	23	34	72	72	140	180
Thermal losses(2) Ua (W/K). Flexible M1	0.384	0.232	1.38	1.657	2.231	2.778

(1) Risers not mounted.

(2) Storage at 65°C – Ambient temperature at 20°C. Values supported per RT2012.

## Dimensions

### 100 L & 200 L

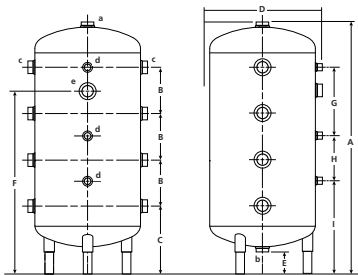

### 500 L

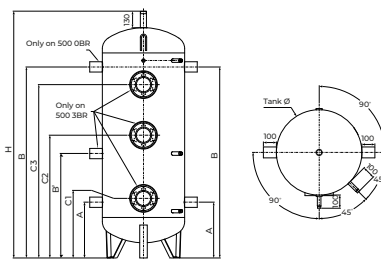

Front view

Top view

### 900 - 1500 L

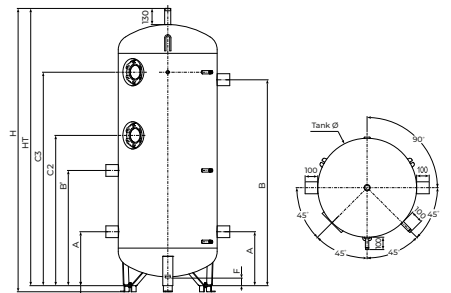

Front view

### 100 & 200 L models

Refs	100L	200L
A	950	1435
B	170	330
C	255	265
D	460	510
E	80	80
F	690	1070
G	255	485
H	170	325
I	345	440
a	1 1/4" F	1 1/4" F
b	1 1/4" F	1 1/4" F
c	1 1/4" F	1 1/4" F
d	1 1/2" F	1 1/2" F
e	1 1/2" F	1 1/2" F
Weight (kg)	23	34

### 500 0F, 500 3F, 900 2F, 1500 models

Refs	Designation	Units	Tank Models			
			500 0F*	500 3F*	900 2F*	1500
Tank Ø	Tank diameter without insulation	mm	650	650	790	1000
HT	Tank overall height (height without riser)	mm	1950	1950	2215	2215
H	Height with risers	mm	1950	1950	2265	2265
A	Lower connection	mm	440	440	430	500
B	Upper connection	mm	1510	1510	1645	1460
B'	Intermediate connection	mm	-	825	920	915
C1	Lower flange height	mm	-	470	-	-
C2	Intermediate flange height	mm	-	970	1200	1077
C3	Upper flange height	mm	-	1370	1705	1630
F	Drainage height	mm	110	110	60	60
R	Riser height	mm	-	-	50	50
1	Temperature probe branch pipe				F15/21 Through type	
2	Thermometer branch pipe				F15/21 Through type	
3	Branch pipe connection			F 66/76	F 80/90	
4	Purge			M 40/49	M 50/60	
5	Drain				F 33/42	

\* 0F = 0 Flanges, 2F = 2 Flanges, 3F = 3 Flanges

# Building Information Modelling (BIM)

Working in partnership with **bimstore**, we have produced data enriched 3D BIM objects available for our range of commercial heating and hot water products.

Our range of BIM objects offer a host of configurable options built in for you. They are loaded with extensive metadata including size, outputs, efficiencies, dimensions, clearance zones and pipe kit options.

The benefits of BIM are huge, including improved collaboration and design co-ordination. Wastage in materials and on-site production are reduced and BIM will also assist in asset and lifecycle management.

Visit our website to download the latest BIM drawings for your project.



SCAN ME

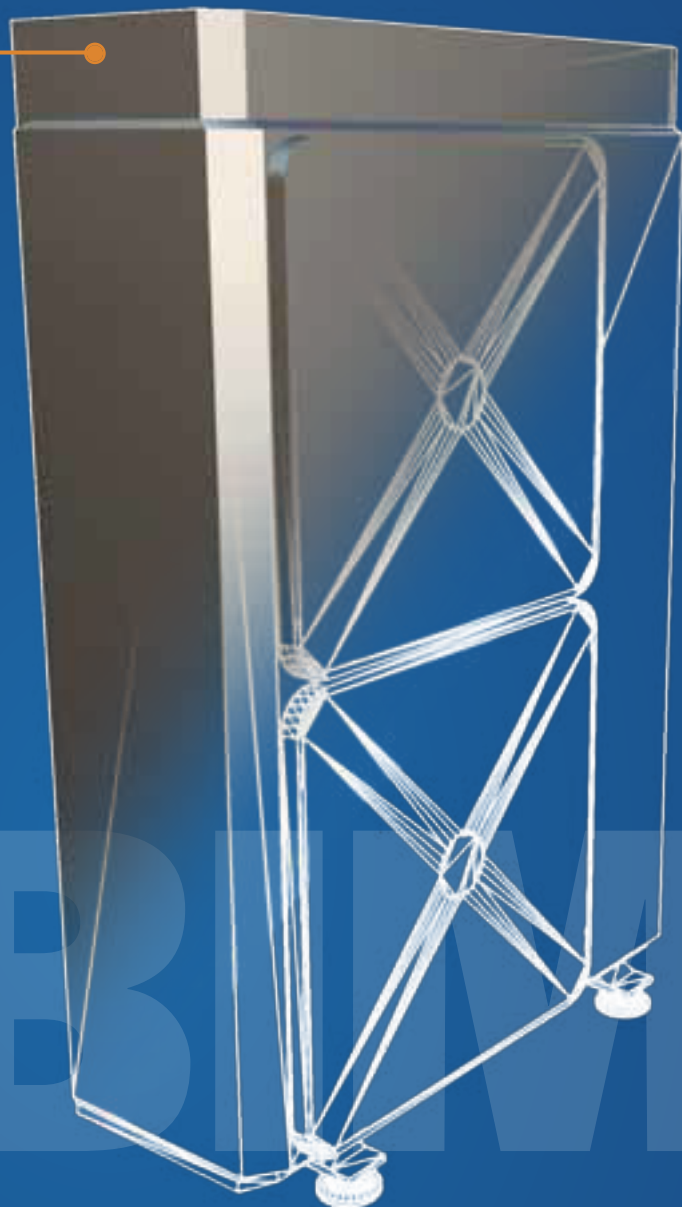

Wireframe



Vertex Normals



Matcap





# Flues

Our boilers and water heaters are suitable for many flue systems and we can provide flue components to suit these schemes. You can choose from the flue types below or a bespoke flue system can be designed by our flue partner, Jeremias.

## Types of flue systems available

### Open flue

Combustion air supply is drawn directly from the room, and flue gases may be discharged through a flue system using either an existing chimney (subject to suitability) or a ducted flue system. The plant room requires ventilation to provide air for combustion and cooling the plant room, in accordance with BS5440 and BS6644.

The flue system will typically rise to the top of the building and discharge above roof level, although some modern low output gas boilers may have an open flue system terminating at low level (in accordance with flue discharge requirements).



**Subject to specific risk assessment procedures detailed in IGEM/UP/10 Edition 4, room sealed appliance installations up to 333kW total Nett input may be terminated at low level.**



### Room sealed

Combustion air supply is drawn via ducts from outside. Flue gases may be discharged through either a concentric or twin duct flue system. The plant room requires ventilation in accordance with BS5440 and BS6644. Plant rooms will require less ventilation than open flue systems, and with reduced airflow, warmer room temperatures are possible - a useful point when designing tighter buildings.

Room sealed appliances reduce the risk of flue gases spilling back into the plantroom due to poor flue operating conditions. In certain buildings the boiler can be installed within occupied spaces where a dedicated plant room may not exist.

### Concentric flue

A concentric flue system provides a very compact room sealed flue, where the air supply and flue gases are managed within a one piece concentric duct system. Typically using a duct within a duct, the flue gases are expelled through the inner duct with combustion air being drawn in via the outer annulus.

A concentric flue system will have the option for the terminal to be positioned horizontally for exiting the building through the wall, (subject to IGEM UP10) or vertically through the roof. The need to only penetrate the building (roof or wall) with a single hole is an advantage



**Modern condensing boilers generate condensate from the flue gases at a rate of around 13 litres per hour for a 100kW boiler, in condensing conditions.**

### Coping with condensate

When changing from atmospheric boilers to condensing, the existing flues on this type of system are not able to deal with a modern pressurised and wet system where condensate will form. The flue system must be water and pressure tight, and designed to drain the condensate from the flue and prevent flow back into the boiler. Where possible, you may be able to make use of the existing chimney with a liner, thus, enabling it to cope with condensing operation.

## How to order flue components

Full details of flue systems can be seen in the individual product brochures. To simplify the flue ordering process, Hamworthy has a flue order form available for you to call off all your flue component requirements. To request a flue system order form, telephone **01202 662500** or email [sales@hamworthy-heating.com](mailto:sales@hamworthy-heating.com) and state which flue system you are planning to use.

# Expert Academy Training

Get the most from your Hamworthy commercial heating and hot water products with the Expert Academy.

Our experience shows that those who take part in our training sessions have more confidence and competence in running the machinery, meaning less chance of downtime.

Good quality, technical training is our number one priority. We pride ourselves in providing you honest, balanced information. We don't do sales presentations and we certainly don't try to push anything during our training courses. We also love learning from your experiences – we are all about providing you the best quality training programme.

We offer the following training courses at a number of purpose built sites across the UK:

- > Commercial gas boiler range training
- > Advanced control training
- > An introduction to air source heat pumps and the Tyneham range

Each day you will be provided with free reserved parking, refreshments and lunch. We also have a range of specialist tools and equipment available for you to try throughout the course.

To book, or for more information on any of our training courses, speak to your Hamworthy Area Sales Manager.

EXPERT  
ACADEMY

## Book now

Please speak to your Area Sales Manager to discuss and book one of our Expert Academy training courses.



# CIBSE approved CPD courses

**We can offer our CIBSE approved CPD seminars online, or in person – at our site or yours.**

Our flexible approach means that we are able to tailor our training to suit your business. Each CPD seminar typically lasts 45 minutes to 1 hour. A lot of our customers choose to run these at lunchtime so that there is minimal disruption to the working day.



- **Introduction to heat pumps – technology and principles**

Heatpumps will play a major part in the future of commercial heating and hotwater in the UK. Learn about the technology and principles behind heat pumps to help you with your system design and specification.

- **Boiler controls – unwiring the jargon**

Get to know the terminology used in controls and how best to setup your boilers for highest efficiency and performance.

- **New boilers on old heating systems: hydraulic design**

Understand the hydraulic design options available when installing new boilers on old systems.

Learn the difference between open and closed heating systems and how to choose the best method of separating the primary and secondary circuits.

- **Best practice in DHW**

DHW in commercial applications is a big topic, so we've developed a series of 3 independent, 1 hr CPD seminars. Each seminar is CIBSE approved and topics include system design, safety and legislation, and sizing.

## Book now

Please speak to your Area Sales Manager to discuss and book one of our CIBSE approved CPD Courses



[enquiries@expertacademy.co.uk](mailto:enquiries@expertacademy.co.uk)

# Service and warranty

## Commissioning

We strongly recommend that all products are commissioned by our service department. As well as ensuring your product is set up correctly for maximum efficiencies you will receive extra benefits on warranty (see below). On completion, you will get a report with details of the initial operating settings.

## Service

All our products have been designed with ease of service in mind.

To maintain your products, we have a range of servicing options that can be tailored to your requirements. For more information on commissioning and service please contact the Hamworthy Heating service department.

## Warranty

All our products come with a contracted warranty period as standard. Terms and conditions will apply and the warranty period may vary per product.

We offer tailored packages to suit the individual customer requirements, many of which include extended warranty benefits. Full details of warranty terms and conditions are available on request.

**Speak to our service team today to find out more about commissioning and service offering or ask us to add it to your project quote.**

Telephone:  
**01202 662555**

Email:  
**service@hamworthy-heating.com**

Website:  
**hamworthy-heating.com/commissioning**

## Spares

**Essential to any maintenance and service regime is the availability of quality spare parts.**

By coming to us, the Original Equipment Manufacturer (OEM), you can be assured of genuine spare parts and may also benefit from technological improvements. We have a long-term commitment to spare parts for our products.

# The Hamworthy difference

## Delivery

Each product is despatched fully assembled and factory tested with the casing and control panel fitted.

Boilers are delivered to ground level and are closely co-ordinated with the customer, to suit the site construction programme.

**Delivery charges may alter across the range of products we offer. To enquire about delivery charges, special delivery services including FORS and time critical deliveries (additional charges apply), please contact our customer services team.**

## British engineering excellence

Here in the UK, we design, test, manufacture and source market-leading products. We know our products inside out, back to front and from start to finish. You can trust that we know what we're talking about.

## Everyone's got history, we've got heritage

Our roots date back to 1914 when two brothers in Poole set up Hamworthy Engineering. Decades of experience go in to every nut, screw and bolt, and every phone call, text and email.

Since 2008, we've been part of Groupe Atlantic, a company with a similar ethos to us. Groupe Atlantic was founded in 1968 by two engineers and is now one of the market leaders in the European heating and hot water industry. We're part of their growing UK, ROI and North America Divisions.



## Lifetime support

From design and specification, through to commissioning, training and maintenance, as well as commitment to spares availability. We support businesses through their lifetime of commercial heating and hot water needs.







**British engineering excellence from Hamworthy Heating;  
the commercial heating and hot water specialists.**



**SUPPORT BRITISH  
MANUFACTURING**



**Hamworthy Heating Limited**

Wessex House,  
New Fields Business Park,  
Stinsford Road,  
Poole, Dorset BH17 0NF

Tel: **01202 662500**

Email: [sales@hamworthy-heating.com](mailto:sales@hamworthy-heating.com)  
[hamworthy-heating.com](http://hamworthy-heating.com)

**Hamworthy Heating Accreditations**

ISO 9001 Quality Management System  
ISO 14001 Environmental Management System  
ISO 45001 Health & Safety Management System

Every effort has been taken to ensure the details in this guide are accurate. Hamworthy Heating does not, however, guarantee the accuracy or completeness of any information nor does it accept liability for any errors or omissions in the information.

Hamworthy Heating reserves the right to make changes and improvements which may necessitate alteration to product specification without prior notice.