

ARNE ECO & ARNE ECO TURBO

**Stainless Steel Flue Gas
Secondary Heat Exchanger**

INSTALLATION, COMMISSIONING AND SERVICING INSTRUCTIONS

IMPORTANT NOTE

**THESE INSTRUCTIONS MUST BE READ
AND UNDERSTOOD BEFORE INSTALLING,
COMMISSIONING, OPERATING OR
SERVICING EQUIPMENT**



Heating at work.

Customer After Sales Services

Telephone: **01202 662555** E-mail: **service@hamworthy-heating.com** Fax: **01202 662522**

Technical Enquiries

To supplement the detailed technical brochures, technical advice on the application and use of products in the Hamworthy Heating range is available from our technical team in Poole and our accredited agents.

Site Assembly

Hamworthy offer a service of site assembly for many of our products where plant room access is restricted. Using our trained staff we offer a higher quality of build and assurance of a boiler built and tested by the manufacturer.

Commissioning

Commissioning of equipment by our own engineers, accredited agents or specialist sub-contractors will ensure the equipment is operating safely and efficiently.

Service Contracts

Regular routine servicing of equipment by Hamworthy service engineers inspects the safety and integrity of the plant, reducing the risk of failure and improving performance and efficiency. Service contracts enable you to plan and budget more efficiently.

Breakdown service, repair, replacement

Hamworthy provide a rapid response breakdown, repair or replacement service through head office at Poole and accredited agents throughout the UK.

Spare Parts

We offer a comprehensive range of spare parts, providing replacement parts for both current and discontinued products. Delivery options are available to suit you. Please refer to our website for more details.

ARNE ECO & ARNE ECO TURBO

**Stainless Steel Flue Gas
Economiser**

Installation, Commissioning and Servicing Instructions

*NATURAL GAS I_{2H}
LPG PROPANE I_{3P}
CLASS D (35 sec fuel oil)*

THE ARNE ECO RANGE OF ECONOMISERS ARE INTENDED FOR USE WITH ENSBURY LT & MELBURY HE BOILERS. THESE INSTRUCTIONS MUST BE READ IN CONJUNCTION WITH THE BOILER INSTRUCTIONS! THE ARNE ECO RANGE CAN ALSO BE USED WITH OTHER MANUFACTURERS BOILERS,

**THE GAS FIRED VARIANTS ARE FOR USE ON GROUP H NATURAL GAS (2ND FAMILY) I_{2H} & LPG PROPANE (3RD FAMILY) I_{3P}.
THE OIL FIRED VARIANTS ARE FOR USE ON CLASS D (35 sec FUEL OIL) or CLASS C2 - KEROSENE (28 sec OIL) OR BLENDED BIO- FUEL (RME or FAME).
PLEASE ENSURE RELEVANT INFORMATION REQUIRED WITHIN THE DOCUMENT IS FOUND RELATING TO THE SPECIFIC FUEL TO BE FIRED, BEFORE OPERATING IN CONJUNCTION WITH THE BOILER.**

THIS PRODUCT COMPLIES WITH EUROPEAN DIRECTIVES -

Electro magnetic compatibility (89 / 336 / CEE)
Low voltage (73 / 23 / CEE)

PUBLICATION NO. 500001194
ISSUE 'A'

CONTENTS

PAGE

1.0 INTRODUCTION.....4

2.0 SUPPLY AND DELIVERY.....5

3.0 GENERAL REQUIREMENTS.....7

4.0 SITE LOCATION AND PREPARATION..... 11

5.0 INSTALLATION..... 19

6.0 PRE-COMMISSIONING 20

7.0 CHECKS AFTER LIGHTING 20

8.0 CONTROLS AND OPERATION..... 21

9.0 FAULT FINDING 21

10.0 SERVICING 21

11.0 RECOMMENDED SPARES 22

APPENDIX A PERFORMANCE DATA..... 23

APPENDIX B ELECTRICAL CONNECTIONS AND CONTROLS..... 25

APPENDIX C FLUE DATA 26

APPENDIX D VENTILATION..... 28

APPENDIX E WATER DATA..... 28

FIGURES**PAGE**

Figure 1.1	Arne Eco Economiser	4
Figure 2.1	Package dimensions.....	5
Figure 2.2	Arne Eco principles.....	6
Figure 2.3	Arne Eco Turbo principles.....	6
Figure 3.1	Arne Eco dimensions.....	7
Figure 3.2	Arne Eco dimensions.....	7
Figure 3.3	Arne Eco dimensions.....	8
Figure 3.4	Arne Eco Turbo dimensions.....	8
Figure 3.5	Arne Eco Turbo dimensions.....	9
Figure 3.6	Arne Eco Turbo Installation.....	9
Figure 3.7	Arne Eco & Turbo clearances.....	10
Figure 4.2	Connection to the flue system.....	12
Figure 4.5	Arne Eco controls wiring.....	16
Figure 4.6	Ensbury & Melbury control panel wiring.....	17
Figure 4.7	Arne Eco Turbo electrical connections.....	18
Figure 4.8	Arne Eco Turbo control panel dimensions.....	18
Figure 5.5	Arne Eco Turbo control panel wiring diagram.....	19
Figure 11.1	Arne Eco & Eco Turbo spares.....	22
Figure A1	Arne Eco Performance data.....	23
Figure A2	Arne Eco Turbo Performance data.....	23
Figure B1	Arne Eco Turbo electrical data.....	25
Figure B2	Arne Eco Turbo electrical connections.....	25
Figure C1	Arne Eco combustion circuit information.....	27
Figure C2	Arne Eco combustion circuit information.....	27
Figure C3	Arne Eco combustion circuit information.....	27
Figure E 1	Arne Eco hydraulic circuit information.....	28
Figure E 2	Arne Eco hydraulic circuit information.....	29
Figure E 3	Arne Eco Turbo hydraulic circuit information.....	30
Figure E 4	Arne Eco installation schematic.....	31
Figure E 5	Arne Eco installation schematic.....	32

1.0 INTRODUCTION

1.1 The Arne Eco and Arne Eco Turbo range of flue gas economisers consists of 16 models, for use with boilers with outputs ranging from 95kW to 6470kW. Refer to Technical Data in Appendix A for details on Natural gas, Propane and Oil firing.

For applications firing blended Bio Fuel (RME or FAME), please refer to Hamworthy Heating Ltd for confirmation and guidance on the fuel specification.

1.2 Arne Eco models utilise the burner to drive the flue gases through the economiser and are suitable for both oil and gas firing.

Refer to Appendix A for burner matchings suitable for Ensbury LT & Melbury HE boilers.

For other manufacturers boilers, refer to the manufacturer confirming the increased resistance through the flue circuit such that a suitable burner can be matched.

Arne Eco models must be dose coupled to the boiler and by using the latent heat present in the flue gases, the efficiency can increase to over 107% (net) at a correspondingly low return temperature.

Arne Eco Turbo models are fitted with a fan in the flue gas circuit and are **only** suitable for gas firing. Accordingly the Arne Eco Turbo can be located in any position in the flue system - **refer to section 3**

All Arne Eco models are manufactured from stainless steel tubes and headers fitted with flanged flow and return connections. The flue gas circuit is provided with two access doors for maintenance purposes



Figure 1.1 - Arne Eco economiser

IMPORTANT

The Arne Eco range requires specific attention to the system design so as to achieve the increased efficiency performance and to maintain the minimum flow requirements through the economiser - **refer to Appendix E for specific information.**

A differential pressure switch is supplied loose to ensure minimum flow is achieved. This must be fitted across the pump.

A limit thermostat and sensor pocket is supplied loose to protect from excessive water temperatures - refer to Appendix E for additional information

A dedicated circulating pump (not HHL supply) is required to deliver the minimum flow requirements for the economiser circuit.

1.3 All Arne Eco models are factory hydraulically tested ensuring suitability for use on systems with a maximum working pressures of 6bar.

1.4 Arne Eco models are supplied assembled ready for installation on-site and are provided with two lifting eyes attached to the frame. In addition, the unit can be moved about on site using a pallet truck to lift by the frame.

The standard unit is supplied with the flue entry as detailed in figure 1.1.

Adjustable feet are supplied providing 60mm of adjustment to enable accurate alignment of the Arne Eco to the boiler - Refer to Figures 3.1 & 3.2

A version is available (**SF**) with side flue exit from the bottom of the economiser - Refer to Figures 3.1 & 3.2

1.5 Arne Eco models provide efficiency performance gains of 6 - 18% depending upon the return water temperature. Refer to Appendix A for performance data

1.6 The heat exchanger is mounted within a steel frame, to which the casing panels provide access for cleaning. The heat exchanger assembly is provided with insulation to minimise stand by losses.

The flow / return and water drain connections are located at the side of the unit. Refer to Section 3 for details.

The heat exchanger is housed in a powder coated sheet steel casing and is provided with levelling feet.

Arne Eco Turbo models are supplied with an ancillary control panel to manage the operation of the exhaust fan in conjunction with the water flow switch.

2.0 SUPPLY AND DELIVERY

2.1 The Arne Eco unit is supplied palletised.

Remove all packing material and inspect the equipment to ensure that all parts are present and undamaged. If in any doubt, **DO NOT USE THE EQUIPMENT.** , contact Hamworthy Heating Ltd.

All packaging materials are to be disposed of appropriately. Prior to installation, remove the wooden blocks from the base, used for transport purposes.

Warranty

Full warranty assistance will be covered when the appliance is commissioned by Hamworthy Heating Ltd, see Terms & Conditions for full details.

Hamworthy Heating Ltd will not accept any liability resulting from damage due to tampering, improper use, handling, installation errors, operation and maintenance. It is important to check for damage upon receipt of product, which if found must be notified to Hamworthy Heating Ltd immediately.

Tel - 0845 450 2866

Delivery Verification

When taking delivery please ensure that you have received the correct number of parts to fulfil your order. The Arne Eco and ancillary items are shipped on one pallet.

If any item is missing please contact our after sales service team. Please provide details of your order such as order number and contract number as well as a detailed description of the missing item.

Figure 2.1 - Packaged Dimensions

Model	H mm	W mm	L mm	Weight (kg)
Arne Eco 130	1120	540	820	135
Arne Eco 200	1200	540	1020	160
Arne Eco 300	1300	540	1300	190
Arne Eco 465	1560	540	1040	205
Arne Eco 710	1630	540	1360	250
Arne Eco 1080	1770	650	1480	335
Arne Eco 1430	1720	710	1630	335
Arne Eco 1870	1910	770	1860	510
Arne Eco 2440	2260	870	2180	660
Arne Eco 3230	2600	980	2350	825
Arne Eco 4260 (2 packages)	1800 1150	1200 990	2500 2200	1015
Arne Eco 5630 (2 packages)	1870 1185	2530 1330	1330 2335	1250
Arne Eco Turbo 400	700	205	1300	205
Arne Eco Turbo 620	750	225	1040	225
Arne Eco Turbo 940	800	280	1360	280
Arne Eco Turbo 1430	900	380	1480	380

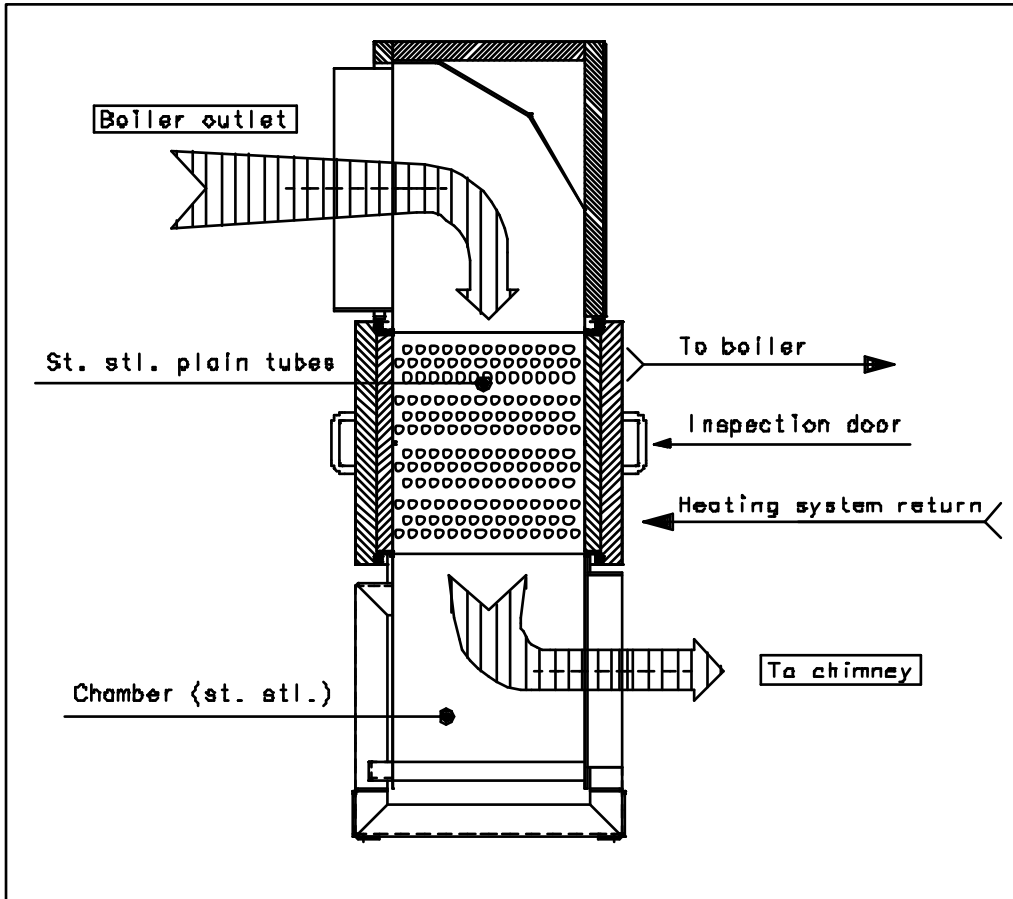

Figure 2.2 - Arne Eco

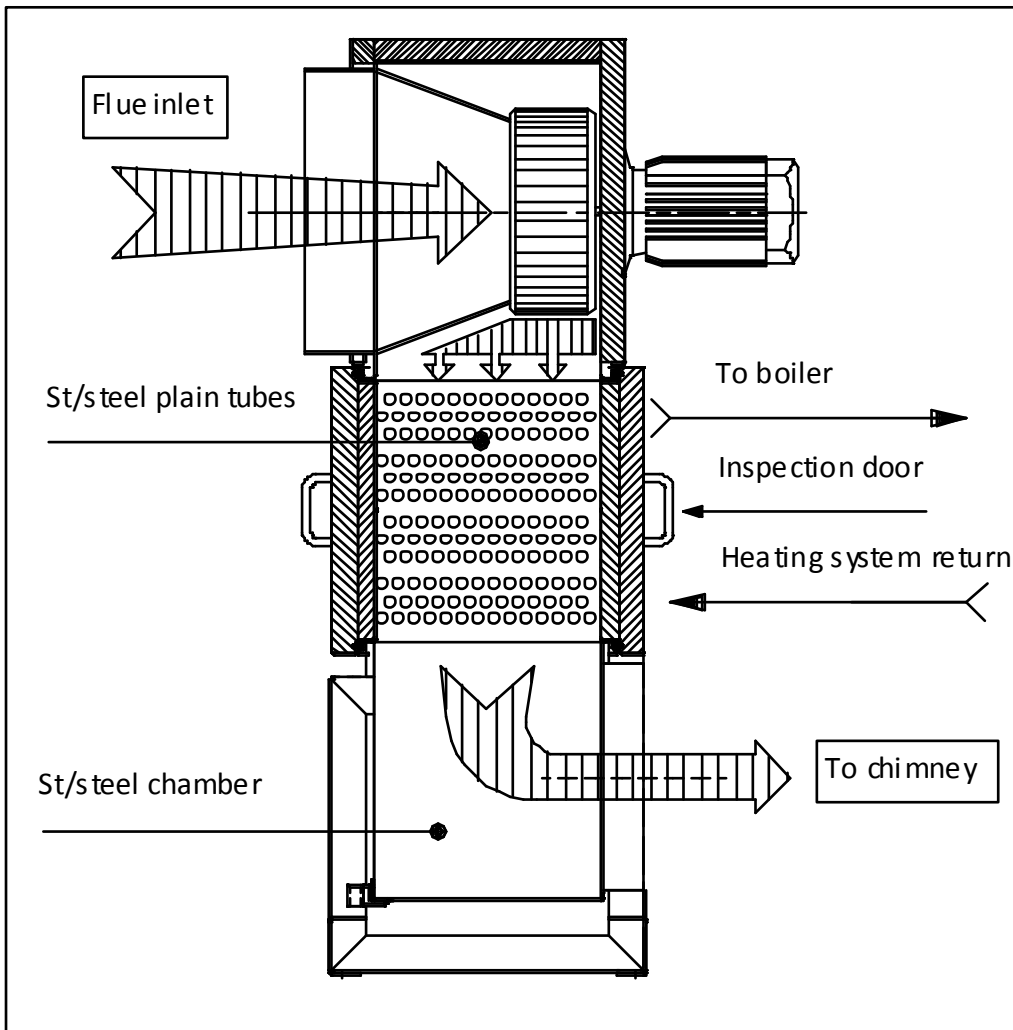

Figure 2.3 - Arne Eco Turbo

3.0 SIZE AND SPACE REQUIREMENTS

3.1 The Arne Eco range has been designed to utilise available space, therefore it is important that the plant room has sufficient ceiling height to allow for installation and connection to the flue system allowing for sufficient access at the rear of the boiler and economiser for pipework connections and maintenance requirements - See Figure 3.3

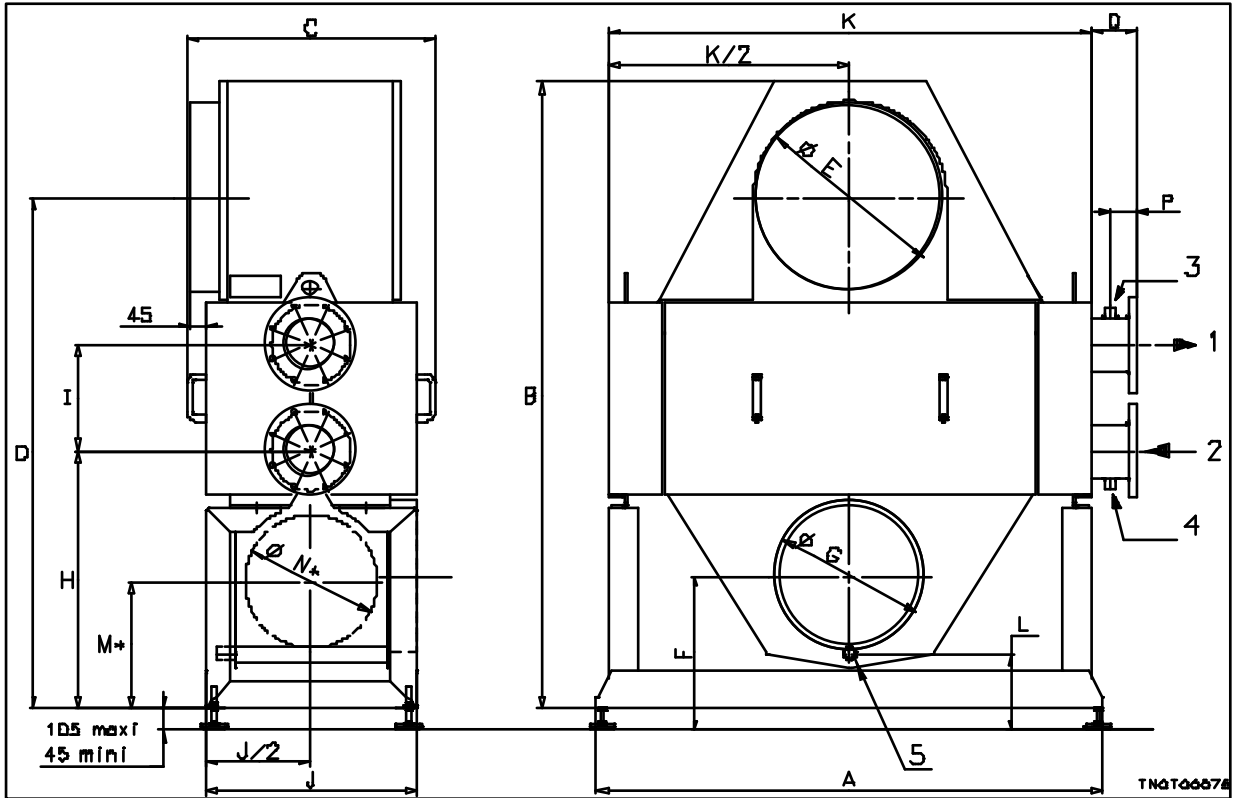

Figure 3.1 - Arne Eco Dimensions (models 130 - 1430)

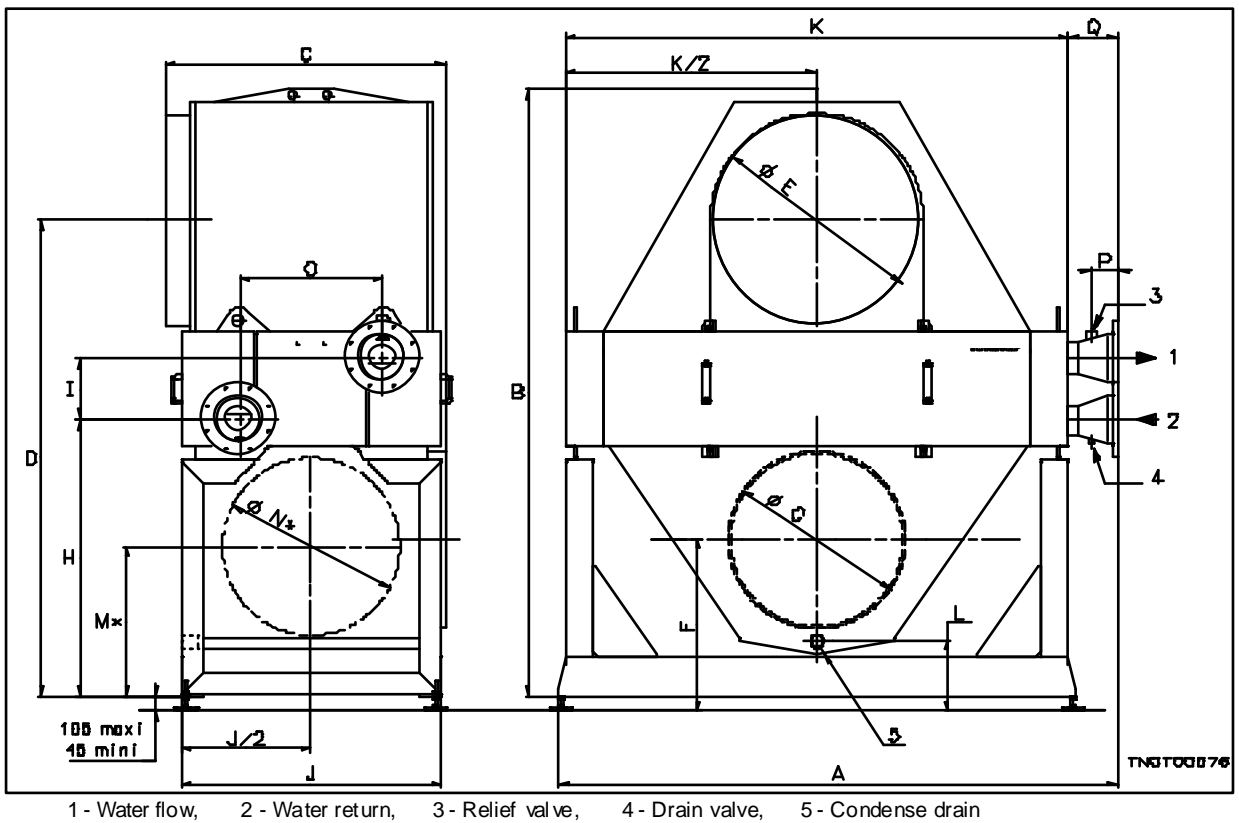

Figure 3.2 - Arne Eco Dimensions (models 1870 - 5630)

Figure 3.3 - Arne Eco Dimensions - refer to figures 3.1 & 3.2

Arne Eco Model		130	200	300	465	710	1080	1430	1870	2440	3230	4260	5630
A, width	mm	770	965	1245	989	1310	1427	1577	1795	2080	2290	2500	2530
B, height	mm	995	1080	1175	1400	1505	1650	1850	1790	2140	2370	2570	2740
C, depth	mm	538	538	538	538	538	650	706	712	820	931	1043	1267
D	mm	840	900	970	1170	1250	1345	1345	1450	1695	1875	2025	2145
E, inlet flue Ø	mm	200	250	300	350	400	500	500	550	650	750	850	950
F	mm	215	250	270	300	330	350	350	415	535	615	690	705
G, outlet flue Ø	mm	200	200	250	300	350	400	400	450	550	650	700	800
H	mm	413	448	493	567	622	680	680	784	945	1075	1175	1245
I	mm	224	224	224	306	306	280	280	252	279	279	279	279
J	mm	448	448	448	448	448	560	616	672	728	840	952	1176
K	mm	621	816	1096	840	1161	1278	1428	1602	1824	2034	2244	2274
L	mm	108	123	138	143	146	143	143	162	228	220	245	245
M*	mm	203	228	259	292	340	343	337	382	506	553	611	682
N*	mm	180	180	200	250	250	350	350	400	500	600	700	800
O	mm	-	-	-	-	-	-	-	205	340	374	424	648
P	mm	70	70	70	70	70	70	70	80	120	120	120	120
Q	mm	119	119	119	119	119	119	119	163	226	226	226	226
Flow / return - (1 & 2)	DN	65	65	65	100	100	125	125	150	200	200	200	200
Relief valve - (3)	DN	½"	½"	½"	½"	½"	½"	½"	1"	1"	1"	1"¼	1"¼
Drain Valve - (4)	DN	½"	½"	½"	½"	½"	½"	½"	½"	½"	½"	½"	½"
Condense drain - (5)	mm	32	32	32	32	32	32	32	32	63	63	63	63

* Dimensions M and N are valid only for the option 'side flue exit'.

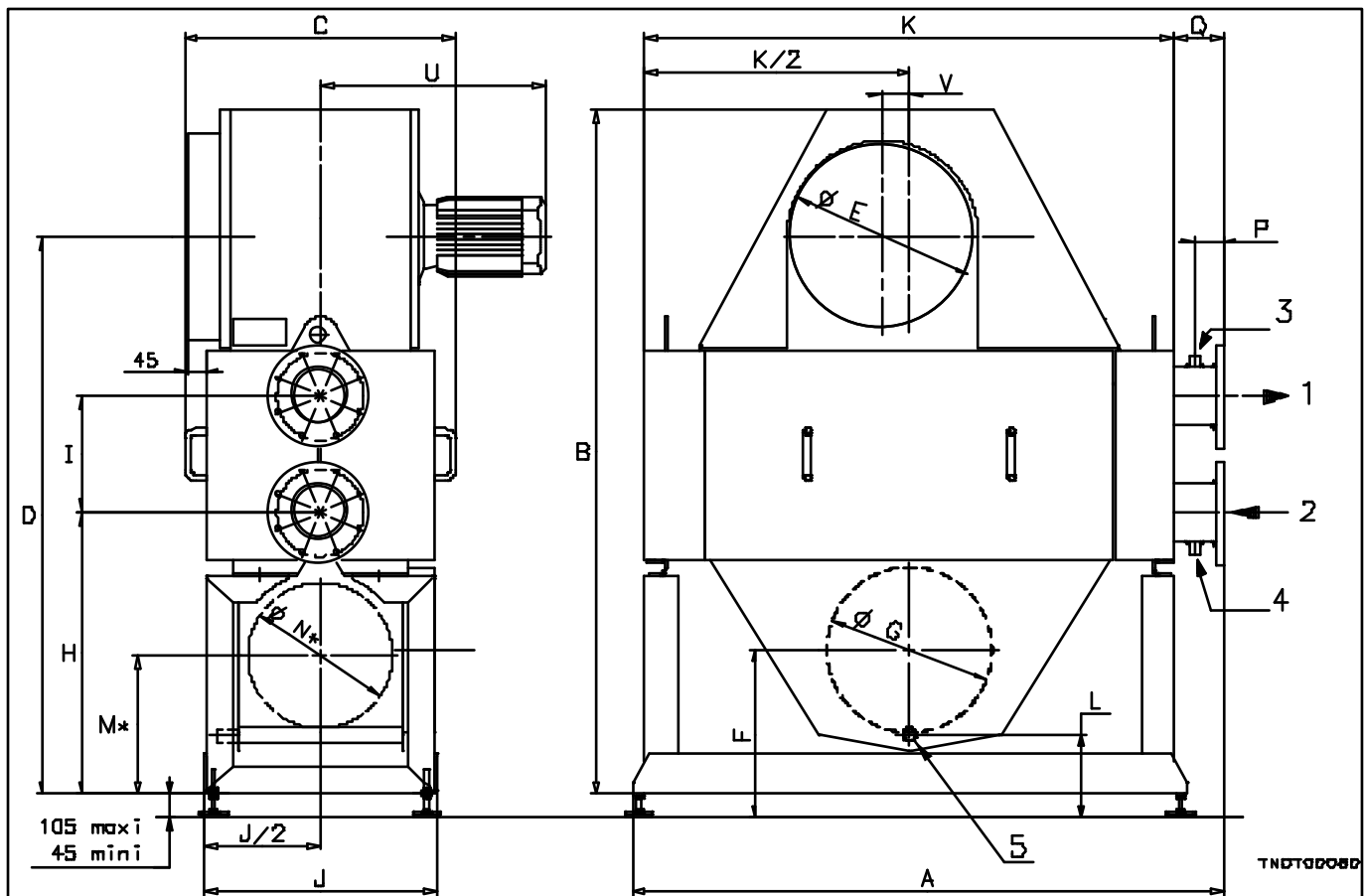

Figure 3.4 - Arne Eco Turbo Dimensions

Arne Eco Turbo Model		400	620	940	1430
A - width	mm	1245	989	1310	1427
B - height	mm	1245	1540	1675	1810
C - depth	mm	538	538	538	650
D	mm	1025	1250	1355	1450
E - inlet flue Ø	mm	250	350	400	450
F	mm	270	300	330	350
G - outlet flue Ø	mm	250	300	350	400
H	mm	493	567	622	680
I	mm	224	306	306	280
J	mm	448	448	448	560
K	mm	1096	840	1161	1278
L	mm	138	143	146	143
M*	mm	259	292	340	343
N*	mm	200	250	250	350
P	mm	70	70	70	70
Q	mm	119	119	119	119
U	mm	397	429	493	544
V	mm	35	50	50	65
Flow / return - (1 & 2)	DN	65	100	100	125
Relief valve - (3)	DN	½"	½"	½"	½"
Drain Valve - (4)	DN	½"	½"	½"	½"
Condense drain - (5)	mm	32	32	32	32

* Dimensions M and N are valid only for the option 'side flue exit'.

Figure 3.5 - Arne Eco Turbo Dimensions - refer to Figure 3.4

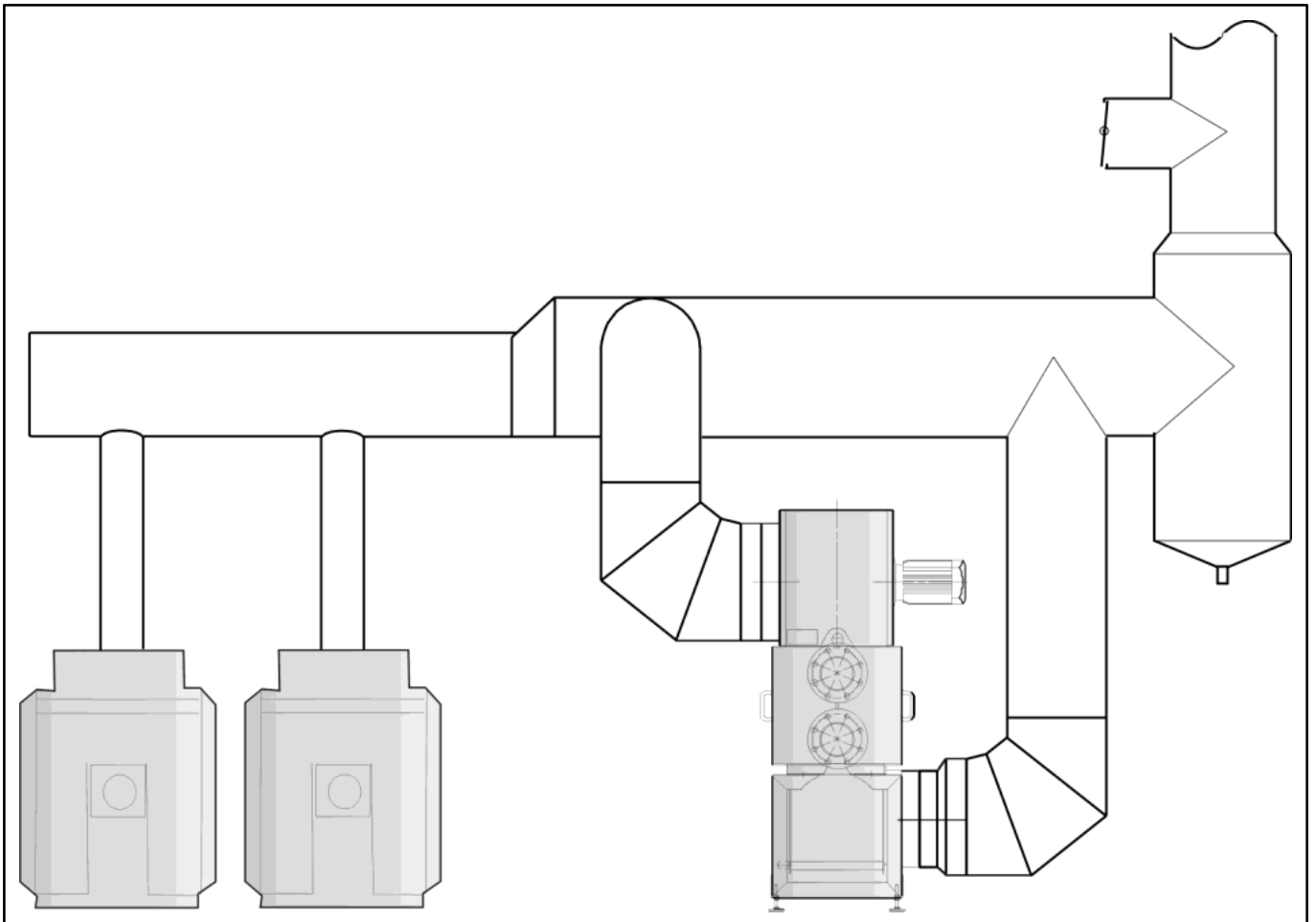

Figure 3.6 - Arne Eco Turbo Installation

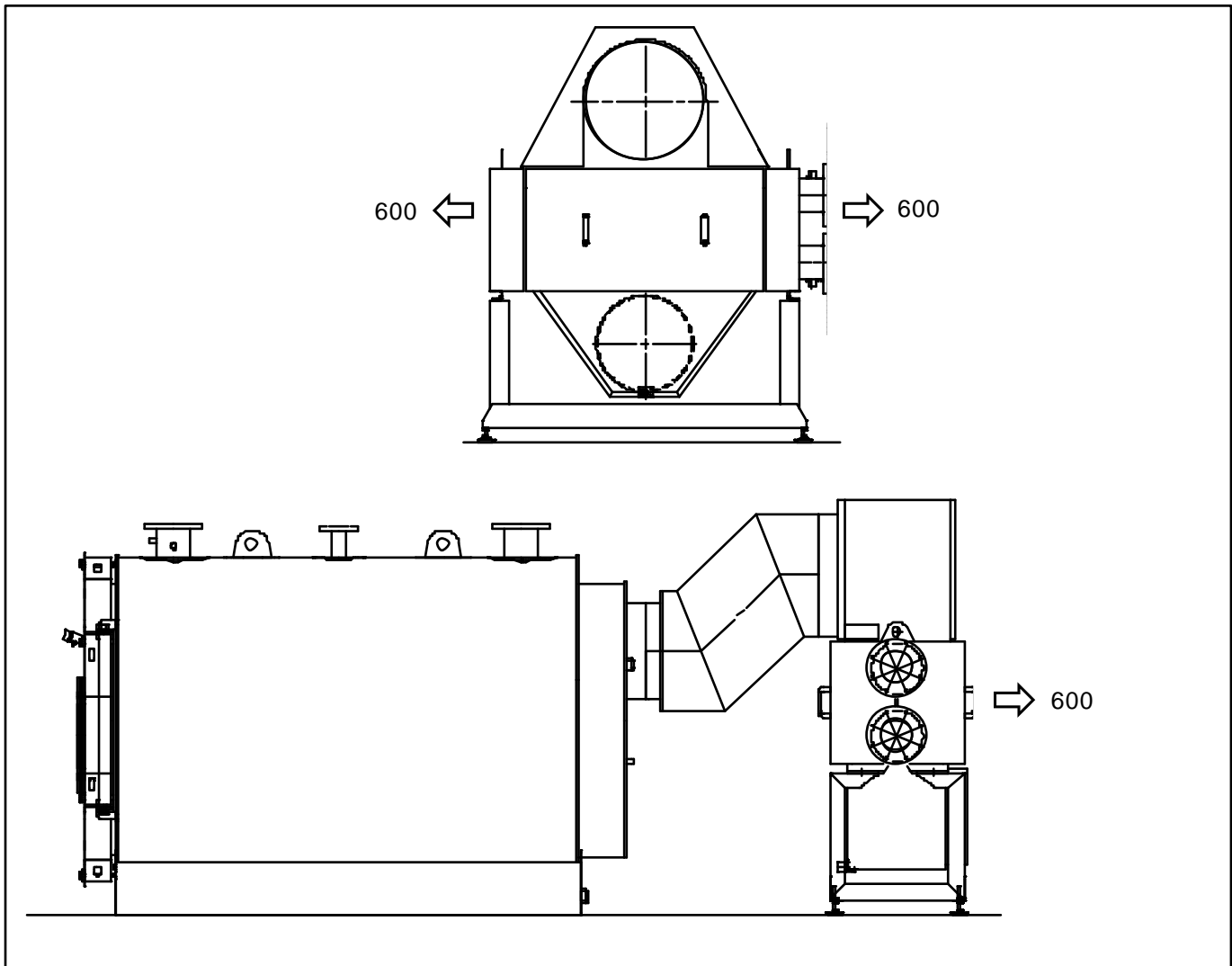

Figure 3.7 - Arne Eco & Arne Eco Turbo Clearances

Clearances

It is essential to provide sufficient clearance to allow access when working on the boiler and Arne Eco unit - refer to figure 3.6.

Sufficient distance must be provided to enable the fitting of a flue adapter, which must be the same size as the boiler flue connection.

Height adjustment

In fitting the Arne Eco behind the boiler, it is advisable to use the adjustable feet for fine adjustments. Do not extend the adjustable feet above the limit defined in figures 3.1, 3.2 & 3.4.

4.0 SITE LOCATION AND PREPARATION

4.1 Site Location.

- **The floor or plinth for the boiler(s) and Arne Eco, must be both flat and level to ensure correct alignment of fittings and connections.**
- **The floor or plinth must be sufficiently strong to support the weight of the boiler(s) and economiser (when full of water) and pipework.**
- **The floor or plinth must be fireproof in accordance with BS 6644.**
- **The plantroom must have sufficient space for installation of boilers, economisers, pipework, pumps, controls, flues, ventilation, access and servicing and other items of plant.**
- **Sufficient space must be provided around the equipment to allow for access to valves and flue and for installation, servicing and replacement, of components.**

4.2 Flueing

- **Flue termination, routing and construction must comply with the requirements of the Clean Air Act 1956, BS 6644, BS 5440 and IGE/UP/10 where applicable.**
- **All Arne Eco models are suitable for open flue (type B₂₃) installation, with the boiler(s) drawing combustion air from the plant room.**
- **Due to the low flue gas temperature on start-up and in normal running (dependent upon return temperature), condensation will occur in the flue leaving the Arne Eco. Flue materials must be non-corrosive and utilise fully sealing joints.**
- **it is recommended that the flue system shall be adapted to its design diameter as soon as possible, after leaving the Arne Eco.**
- **Flue systems must be self supporting, contain access for cleaning and contain a maintenance joint near the boiler and economiser outlets to allow for routine cleaning.**
- **Existing chimneys should be thoroughly swept before use and any register plates, dampers, or restrictions removed. Existing chimneys must be lined with a suitable liner.**
- **Chimneys should be lined with a non-porous acid-resistant material in accordance with BS.5854, e.g. a flexible flue liner or similar British Gas Approved material. The internal diameter of the liner must not be less than the recommended flue size and the number of joints should be kept to a minimum.**
- **It is recommended that a draught stabiliser is fitted to the flue system where the suction is likely to exceed 0.3mbar. The flue system should be designed to maintain atmospheric pressure or a slight suction at the boiler flue connection at all times (0.1 - 0.3mbar).**
- **Combustible materials in the vicinity of the boiler and flue shall not exceed 65 °C during operation. The flue shall not be closer than 50mm to any combustible material, except where it passes through such material with a non-combustible sleeve when the air gap may not be less than 25mm.**
- **When designing the flue system, care must be taken to ensure that any condensate which may form within the system, can be safely drained to a suitable waste point and, that the flue material used is resistant to the corrosive effects of that condensate.**

Figure 4.2 - Connection to the flue system

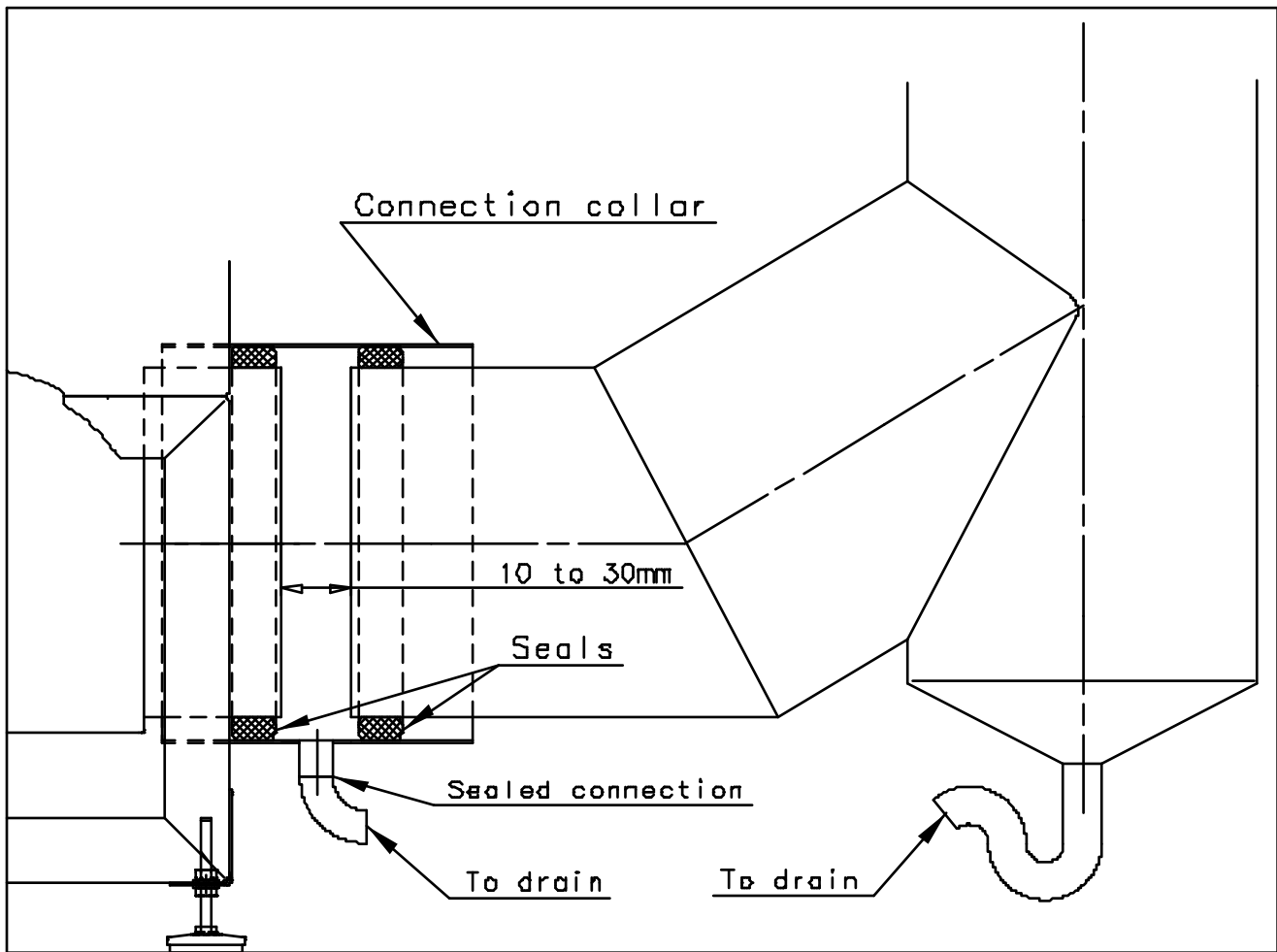

4.3 Water Supply

- The Arne Eco is suitable for operating on open vented or sealed (pressurised) heating systems.
- A dedicated circulating pump (not HHL supply) is required to ensure minimum flow rates are achieved through the economiser - refer to Appendix E for flow rates and duty.
- A differential pressure switch is provided to prove that minimum water flow rates are achieved through the economiser. This **MUST** be connected across the pump flow and return connections.
- Pressurised system to comply with BS 7074. The flow connection is fitted with a connection for the use of a suitably sized safety valve - refer to BS6644.
- Feed Water Quality - The condition of the feed water quality must be controlled:

Hardness	- <100mg CaCO ₃ /l.
pH	8.3 - 9.5
Phosphates (PO ₄)	- <30 mg/l
Chlorides (Cl)	- <50 mg/l
Oxygen (O ₂)	- <0.1 mg/l
- It is strongly recommended that the system pipework is flushed at least twice before adding water treatment and before installing the boiler and economiser.
- In hard water areas (>100mg CaCO₃/litre) precautions such as water treatment are strongly recommended to prevent the build up of sludge and scale.
- Leaks in the system pipework must be repaired to prevent dilution of water treatment.
- Maximum working water pressure is 6bar.
- Minimum water pressure 0.5 bar
- Care must be taken to ensure that oxygen does not enter the system via the open feed tank, or system materials which allow the transmission of oxygen into the system.

If this cannot be prevented, additional measures are necessary in the form of correctly used oxygen binding agents or chemicals.
If it is not possible, consideration must be given for separation of the boiler from the system using for example plate heat exchangers.
- A coarse filter and dirt separator in the return to both boiler(s) and economiser **MUST** be fitted. The use of an automatic air vent is recommended.
- Specific attention must be made to the system design so as to achieve the increased efficiency performance and to maintain the minimum flow requirements through the economiser - refer to Appendix E for specific information.
- The pump and economiser should be fitted with suitable isolating valves to allow maintenance and replacement, should it be necessary.

4.4 General Requirements

- **Related Documents** - Gas Safety (Installation and Use) Regulations 1994 – (As amended). It is the law that all gas appliances are installed by competent persons, in accordance with the above regulations. Failure to do so, could lead to prosecution. It is in your own interest, and that of safety, to comply with the law. The installation of the boiler **MUST** be in accordance with the relevant requirements of the Gas Safety Regulations, Building Regulations, I.E.E. Regulations and the bylaws of the local water undertaking. The installation should also be in accordance with any relevant requirements of the local gas region and local authority and the relevant recommendations of the following documents :-
 - BS5410 - Code of practice for oil firing. Part 2: Installations of 44 kW and above capacity for space heating, hot water and steam supply purposes.
 - BS.6644 - Specification for installation of gas fired hot water boilers of rated inputs 60kW - 2MW.
 - BS 6700 Design, installation, testing and maintenance of services supplying water for domestic use.
 - BS 6891 Installation of low pressure gas pipe work of up to 35mm (R 1 ¼) in domestic premises.
 - BS 6880 Part 1, 2 & 3 Code of practice for low temperature hot water heating systems of output greater than 45kW.
 - BS 7074 Application, selection and installation of expansion vessels and ancillary equipment for sealed water systems. Part 2 Code of practice for low and medium temperature hot water systems.
 - BS 7671 Requirements for electrical installations. IEE Wiring Regulations. Seventeenth edition.
 - BSEN 806-2 Specification for installations inside buildings conveying water for human consumption. Design.
 - BSEN 12828 Heating systems in buildings, Design for water-based heating systems.
 - **I. Gas E. Publications**
 - IGE/UP/1 Soundness testing and purging of industrial and commercial gas installations.
 - IGE/UP/1A Soundness testing and direct purging of small low pressure industrial and commercial natural gas installations.
 - IGE/UP/2 Gas installation pipe work, boosters and compressors in industrial and commercial premises.
 - IGE/UP/10 Installation of gas appliances in industrial and commercial premises, Part 1 flued appliances.
 - **Health and Safety Executive**
 - Guidance note PM5 - Automatically controlled steam and hot water boilers.
 - **CIBSE Publications**
 - CIBSE Guide B Heating, ventilating, air conditioning and refrigeration.
 - CIBSE Guide H Building Control Systems
 - CIBSE Guide Energy Efficiency in Buildings
 - CIBSE Commissioning Code B: 2002
 - Dept Environment, Scottish Development Dept & Welsh Office
Third edition of the 1956 Clean Air Act Memorandum

4.5 Electrical Supply - Arne Eco Turbo Models

WARNING! THIS APPLIANCE MUST BE EARTHED IN ACCORDANCE WITH IEE REGULATIONS

- **Electrical supplies 415Volt, 50Hz– 3 phase, must not be switched by a time clock.**
- **External fuses should be rated for 6.3 amps**
- **Wiring must be completed in heat resistant cable size 1.0mm² csa.**
- **Each economiser MUST have individual means of isolation.**
- **Electrical isolators must facilitate complete electrical isolation.**
- **Electrical isolators must have contact separation of minimum 3mm in all poles.**
- **Electrical isolators must be installed in readily accessible locations.**
- **Electrical supplies should only serve the economiser.**
- **Wiring of ancillary circuits must be connected to the control panel via the knock-outs in the bottom of the panel, using suitable cable glands.**
- **The pump must be controlled by the BMS panel, providing suitable operation whilst the burner is firing and pump overrun, when the burner switches off.**
- **The flow switch and manual reset limit thermostat set at 100°C (supplied by HHL) must be fitted in accordance with Figures 4.5 & 4.7.**
- **Where an external alarm is required, the Arne Eco Turbo control panel has 1 volt free contact for remote signalling.**

ADDITIONAL INFORMATION REGARDING ELECTRICAL SUPPLIES IS GIVEN IN BS EN60335, Part 1.

NOTE: The appliance must be isolated from the electrical supply if electric arc welding is carried out on connecting pipework.

FOR TYPICAL SCHEMATIC DETAILS SEE FIGURE 4.5 & 4.7

FOR DETAILED WIRING INSTRUCTIONS SEE FIGURE 5.5

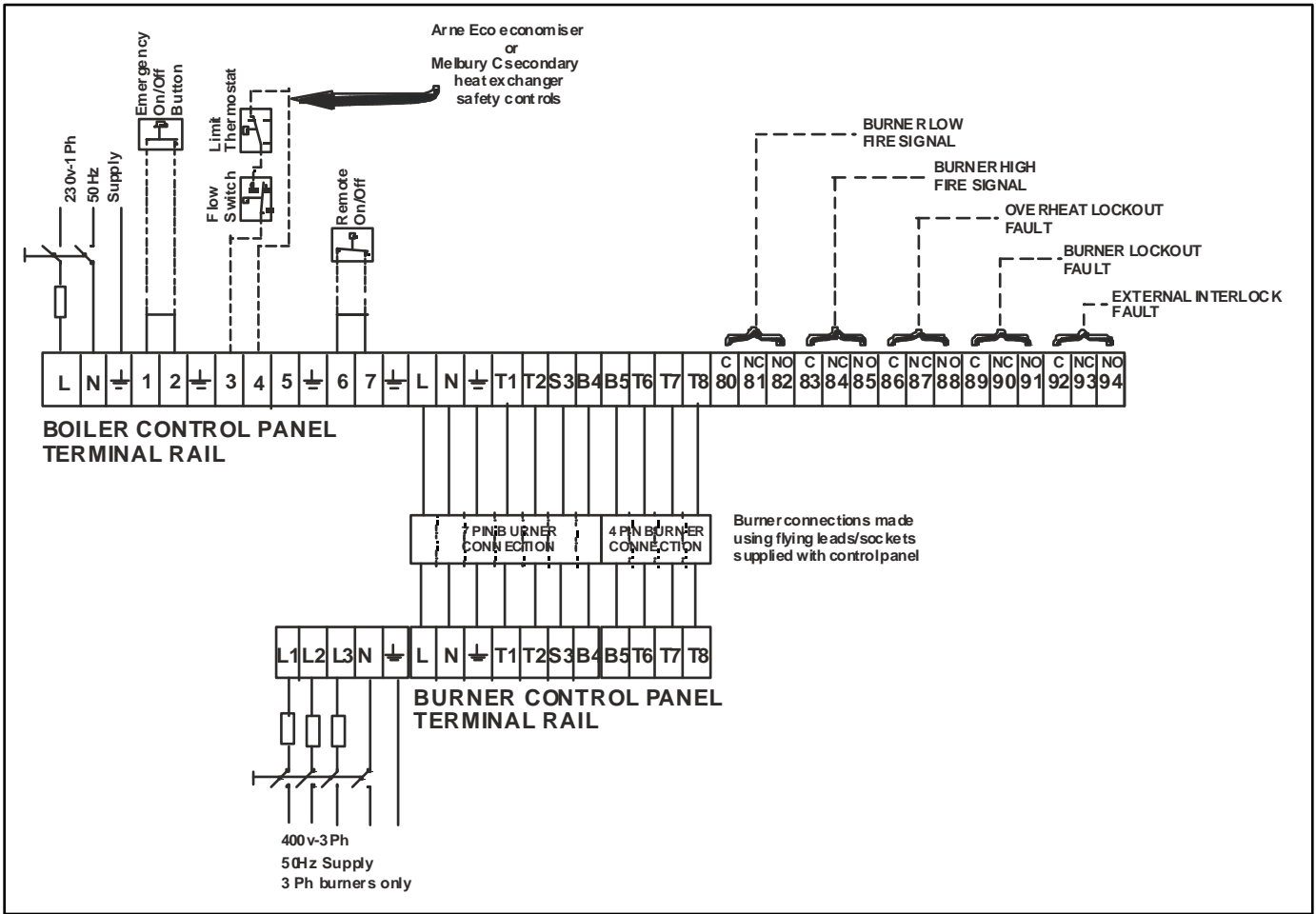

Figure 4.5 - Arne Eco controls wiring to Ensbury LT & Melbury HE boiler control panel

Note: the Arne Eco safety controls (flow switch and limit thermostat) must be connected in series with the safety interlock circuit - terminals 3 & 4 on Ensbury LT & Melbury HE boilers

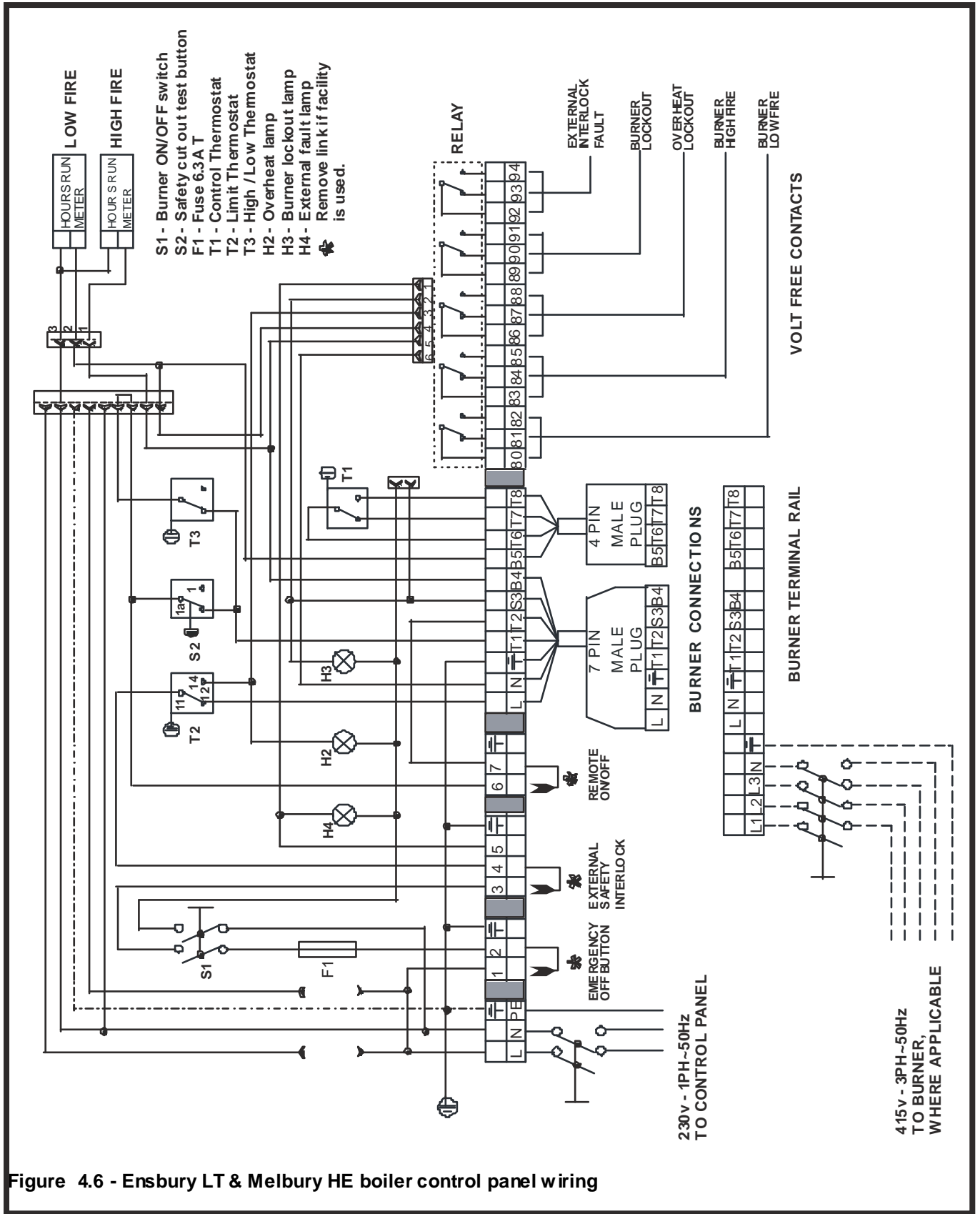

Figure 4.6 - Ensbury LT & Melbury HE boiler control panel wiring

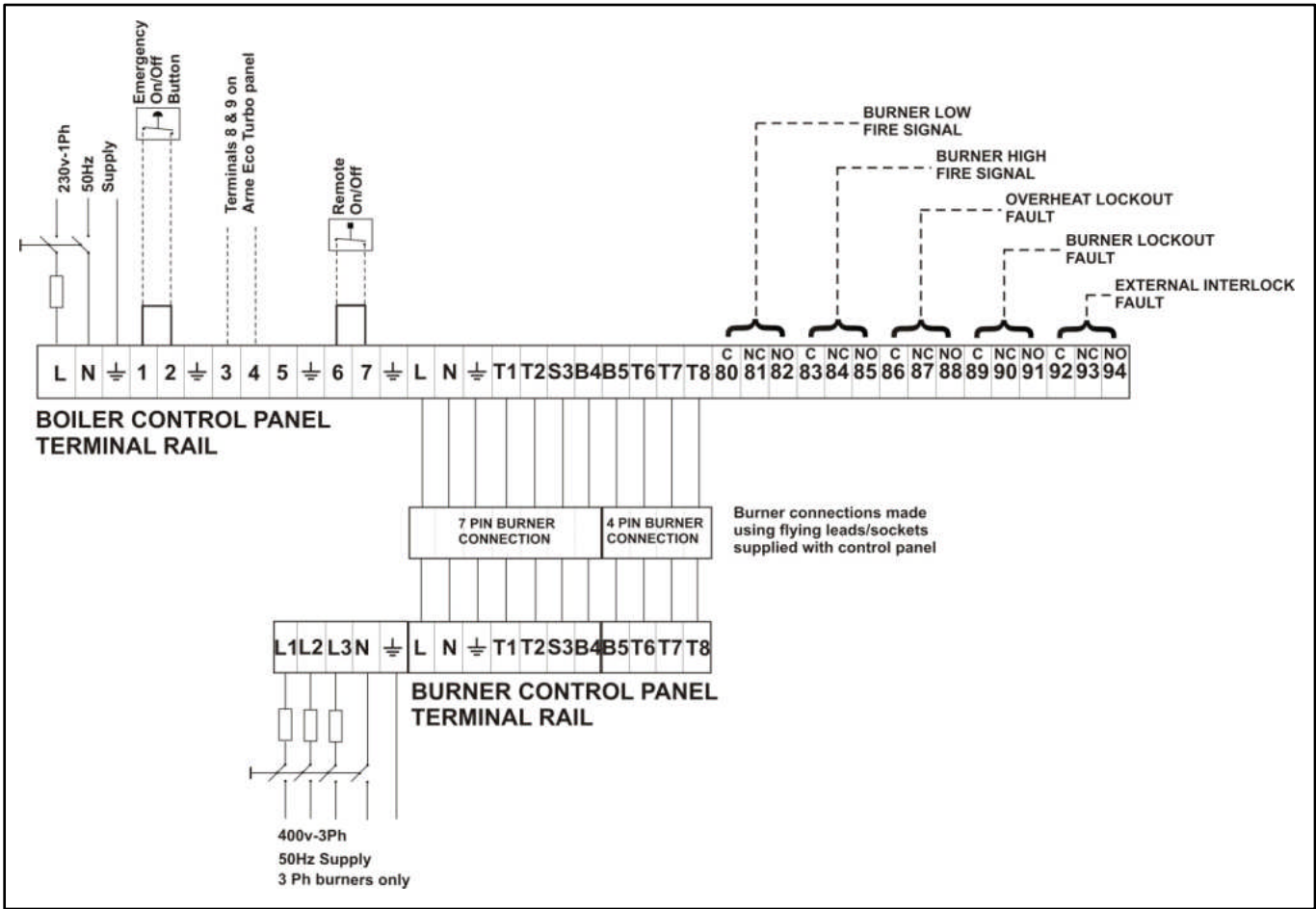

Figure 4.7 - Arne Eco Turbo Electrical connections

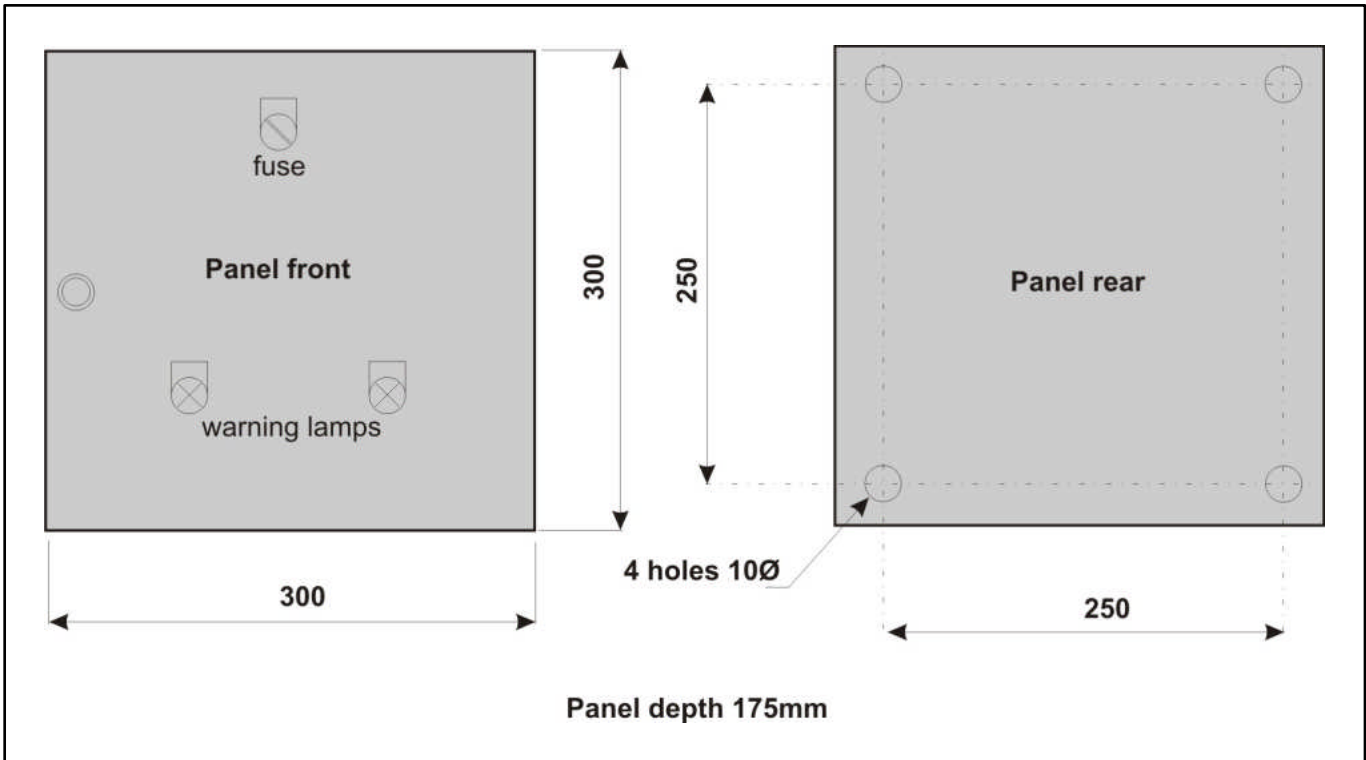

Figure 4.8 - Arne Eco Turbo Control Panel dimensions

5.0 INSTALLATION - all models

Important; - ensure that a suitable flue disconnection fitting is located between the boiler and Arne Eco - see figure 4.2

Site equipment and accessories **MUST NOT** be secured to the casing panels.

Arne Eco Turbo models - the control panel should be wall mounted or on a station close to the economiser. Ancillary equipment wiring **MUST** be connected to the control panel using suitable cable glands at the bottom of the panel.

The separately supplied Limit Thermostat and differential pressure switch providing over temperature and water flow protection **MUST** be fitted into the hydraulic circuit as shown in Appendix E and connected to the electrical controls as shown in figures 4.5, 4.7 & 5.5.

A suitably sized safety valve **MUST** be fitted to the flow connection of the Arne.

A suitably sized circulating pump must be fitted - refer to Appendix E for schematic and sizing.

Before installation, select the appropriate direction for the water headers (left or right) and flue exit (centre front or rear), or left or right in the case of an SF unit.

The position of the lower and upper exhaust ducts can be reversed to give flexibility on the installation.

To access the upper exhaust duct, remove the decorative cover to expose the M8 screws securing the duct. The lower duct is also secured in the same manner.

Caution: When refitting the ducts, ensure the seal is correctly positioned and check that it is in good condition.

5.1 Installation

a) Locate the Arne Eco behind the boiler ensuring that it is level and lined up with the boiler flue

Figure 5.5 – Arne Eco Turbo Control Panel Wiring Diagram

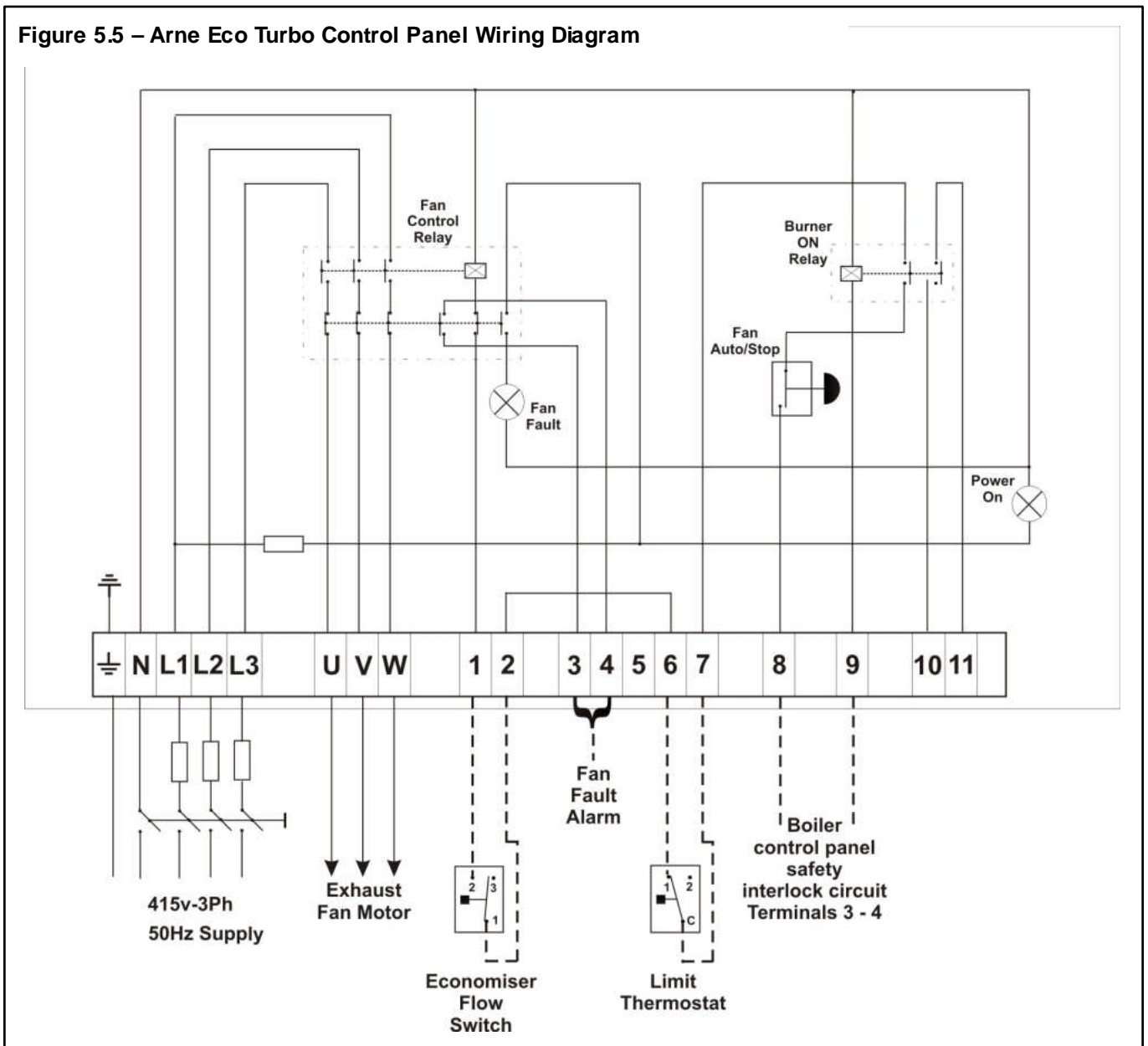

makeup piece. Test fit the flue make up piece before connecting the Arne Eco to the system pipe work.

b) Connect the system pipe work - refer to Appendix E for installation schematics. Fit a suitable drain to the return connection and an appropriately sized safety valve to the flow connection using the tappings provided.—see figures 3.3 & 3.5.

Note: ensure that the discharge from the safety valve is taken to a safe place.

Fit the differential pressure switch across the circulating pump. For setting of the switch to ensure that minimum flow rates are achieved refer to Appendix E.

The design of the logic is so that should a failure to

detect flow occur, the burner will be held off.

c) Mount the control panel in a suitable location - refer to figures 4.6 & 4.7 and make the electrical connections.

d) Fit a suitable 32mm condense drainage system to the Arne Eco and the flue system ensuring that the discharge is taken to a suitable drain using appropriate materials. Should a siphon be used, access must be provided for inspection and cleaning.

e) A manually resettable thermostat limiting the temperature to 95°C is supplied. This thermostat must be connected across terminals 6 & 7 and in series with any other controls in that circuit - refer to figure 5.5.

6.0 PRE-COMMISSIONING

The following pre-commissioning check must be carried out before the boiler is commissioned.

6.1 Pipework, Valves and Pump

Ensure that;

- Pipework and valve arrangement is installed to Hamworthy Heating recommendations.
- Circulating system is full of water, vented and pressurised appropriately.
- Circulation pump is fitted, working and interlocked.
- Pipework connections to economiser are fitted correctly.
- All necessary isolation valves are open.
- Heat load is available.
- Safety valves are correctly rated and located.

6.2 Flue

Ensure that;

- Flue system is correctly designed and installed to suit the application.
- Flue passages to chimney are clear.
- Condense drains are connected appropriately and discharges taken to a drain

6.3 Electrical

Ensure that;

- Electrical connections are correct and isolatable.
- External controls are operational.

6.4 Ventilation

- Ensure that there is adequate ventilation into the plant room - refer to boiler instructions.

7.0 CHECKS AFTER LIGHTING

- Check the operation of the system.
- Check the integrity of the flue connections
- Condense drains are connected appropriately and discharges taken to a drain
- Check the temperature of the flue gases leaving the Arne Eco and ensure that the entry flue gas temperature is less than 280°C
- Check the operation of the boiler in accordance with the relevant instructions.

8.0 CONTROLS AND OPERATION

8.1 Temperatures

It is essential that minimum flow rates are achieved so as to extract the heat from the flue gases, thus delivering the efficiency gains.

Typical flue gas temperatures leaving the economiser are detailed in Appendix A.

With mixed temperature circuits, it is important that high temperature circuits return directly to the mixed flow header connected to the boiler primary heat exchangers. Accordingly non return valves should be used in the system design - refer to Appendix E.

8.2 Water Flow Controls

The Arne Eco has minimum flow requirements and accordingly a dedicated circulation pump is required to deliver the required flow in the low temperature circuit - refer to Appendix A for pump duties.

Correctly sized circulating pumps and valves must be used in the system to provide the necessary performance.

In the event of inadequate or no flow, the water flow switch will hold off the boiler firing until the minimum flow requirement is satisfied.

8.3 Frost Protection

Consideration should be given to fitting a frost thermostat set at approximately 4°C.

8.4 Unvented Systems

Refer to the boiler instructions for guidance on unvented systems.

9.0 FAULT FINDING

9.1 Fault Finding

Fault finding on the burner control system is detailed in the burner manufacturers instructions. If the boiler still cannot be operated satisfactorily after following these instructions, consult Hamworthy Heating for assistance.

10.0 SERVICING

A qualified engineer registered for working on non domestic gas or oil appliances should check and ensure that the flue, its support and terminal, the ventilation to the boiler house, safety valve, drain, water filter if fitted, pressure gauge, etc.; are in a serviceable and working condition and still comply with the relevant standards and codes of practice - see **Section 3.1**

The boiler should be serviced at regular intervals, not exceeding SIX months for oil fired boilers, or TWELVE months for gas fired boilers.

When carrying out boiler servicing always consider both your own safety and that of others. The use of protective equipment (e.g. eye protection, face mask, protective gloves, etc.) is recommended where necessary.

10.1 Initial Inspection

a. To gain access to the heat exchanger flue ways, swivel back the two end panels which are latched by magnets. This will expose M8 screws securing the access panels. Repeat the operation for the opposite side.

b. Withdraw the access panels using the handles provided to give access to the heat exchanger tubes. Clean the heat exchanger tubes and flue ways with the brush provided.

c. Arne Eco Turbo models only - remove the decorative cover from the upper exhaust duct, loosen the M8 screws securing the fan motor assembly to the upper chamber; then remove the assembly taking particular care of the seal. Should the seal be compromised, replace.

d. In replacing any components, inspect and renew gaskets and seals where appropriate. Replace and secure the access panel(s), remembering to close the end panels and secure on the magnet latches. This will prevent any undue heat losses

11.0 SPARES

DESCRIPTION	PART NO.
Motor seal Arne Eco Turbo 400	573410259
Motor seal Arne Eco Turbo 620	573410261
Motor seal Arne Eco Turbo 940 & 1430.....	573410262
Door seal Arne Eco 130	573410263
Door seal Arne Eco 200	573410264
Door seal Arne Eco 300 & Turbo 400.....	573410265
Door seal Arne Eco 465 & Turbo 620.....	573410266
Door seal Arne Eco 710 & Turbo 940.....	573410267
Door seal Arne Eco 1080 & Turbo 1430.....	573410268
Door seal Arne Eco 1430.....	573410269
Door seal Arne Eco 1870.....	573410270
Door seal Arne Eco 2440.....	573410271
Door seal Arne Eco 3230.....	573410272
Door seal Arne Eco 4260.....	573410273
Door seal Arne Eco 5630.....	573410274
Brush Arne Eco 130 / 1870 & all Turbo	573410275
Brush Arne Eco 2440 / 4250	573410276
Brush Arne Eco 5630.....	573410277
Differential Pressure Flow Switch type A.....	573410282
Differential Pressure Flow Switch type B.....	573410283
Differential Pressure Flow Switch type C.....	573410284
Limit Thermostat.....	573410285

..

Figure 11 - Arne Eco & Eco Turbo spares

APPENDIX A - PERFORMANCE DATA

Arne Eco - model		130	200	300	465	710	1080	1430	1870	2440	3230	4260	5630
GENERAL DATA													
INPUT													
Minimum power input	kW	95	150	230	350	540	815	1240	1630	2150	2800	3700	4900
Maximum power input	kW	170	260	400	620	940	1430	1630	2150	2800	3700	4900	6470
WATER													
Minimum flow rate	m³/h	3.0	4.0	6.0	8.0	12.0	19.0	25.0	33.0	42.0	56.0	74.0	97.0
Pressure drop @ minimum	mbar	12	13	17	14	20	30	40	55	72	90	125	140
Maximum flow rate	m³/h	7.0	11.0	17.0	26.0	39.0	60.0	80.0	104.0	136	180.0	237.0	313.0
Pressure drop @ maximum	mbar	30	50	120	110	220	270	400	530	720	900	1080	1150
Differential pressure switch selection	A	A	A	A	A	A	A	A					
	B			B	B	B	B	B	B	B	B	B	B
	C					C	C	C	C	C	C	C	C
Example - refer to Appendices for data													
Based upon flue gas inlet temperature 220°C, excess air @20% and full load													
Boiler power input	kW	130	200	300	465	710	1080	1430	1870	2440	3230	4260	5630
Flue gas resistance	mbar	0.3	0.3	0.3	1.7	1.7	1.7	1.7	1.7	1.7	1.8	1.8	1.8
Water flow rate	m³/h	6.51	10.0	15.0	20.0	30.0	45.0	52.0	59.0	66.0	79.0	93.0	120.0
Hydraulic resistance	mbar	25	50	100	75	140	160	170	175	180	182	187	187

Figure A.1 – Performance and General Data Information Arne Eco

NOTE: depending upon the design criteria, the appropriate differential pressure switch must be selected
A - 15~60mbar
B - 40~200mbar
C - 150~1000mbar

Arne Eco Turbo - model		400	620	940	1430
GENERAL DATA					
INPUT - see note*					
Rated power output	kW	400	620	940	1430
WATER					
Minimum flow rate	m³/h	6.0	8.0	12.0	19.0
Pressure drop @ minimum	mbar	17	14	23	30
Maximum flow rate	m³/h	17.0	26.0	39.0	60.0
Pressure drop @ maximum	mbar	120	115	230	290
Differential pressure switch selection	A	A	A	A	A
	B	B	B		
	C			C	C
Example - refer to Appendices for data					
Water flow rate	m³/h	8.0	20.0	30.0	40.0
Hydraulic resistance	mbar	35	70	130	175

Figure A.2 – Performance and General Data Information Arne Eco Turbo

Note * - the model chosen should have a power rating of NOT MORE THAN 4 times the minimum plant firing capacity.

BURNER SELECTION - Ensbury LT & Melbury HE boilers

Referring to the increased flue gas circuit resistance, see figures C1, C2 & C3, caused by the economiser heat exchanger, consideration must be given to the impact on the burner performance such that the firing rate is not adversely affected.

For other manufacturers boiler combinations with Arne Eco economisers, the additional resistance must be added to the boiler combustion chamber resistance defined in the Boiler instructions - refer to boiler manufacturer.

In the case of Ensbury LT and Melbury HE boilers, the following models require revised burner applications to ensure satisfactory performance.

Ensbury LT - model	370	510
Matched Riello burner	RS/RL 44	RS/RL 50
Matched Riello burner for use with Arne Eco	RS/RL 50	RS/RL 70

All other models of Ensbury LT & Melbury HE boilers are suitable for use with Arne Eco economisers using the burners detailed in the Boiler Instructions.

APPENDIX B - ELECTRICAL CONNECTIONS AND CONTROLS

B.1. Electrical Connections:

The following electrical connections are provided on each Arne Eco Turbo control panel.

- Supply: Live, Neutral and Earth. (415V - 3ph ~50Hz) See Section 4.5 for details.
- Fan Fault Alarm Signal Output - volt free
- Economiser Flow Switch
- Auxiliary Burner relay
- Safety Interlock link - to be fitted by Contractor
- Power On lamp
- Fan Fault lamp
- Emergency On/Off Button

Note: All wiring and electrical connections must be completed by a competent person in accordance with current IEE regulations.

Power supply required is 415V 50 Hz three phase, 4 wire. An isolator correctly fused should be sited close to the boiler. Refer to the burner instructions.

Note: The Auxiliary burner relay should be **connected across terminals 3 & 4** on the boiler control panel. Should there be any other external safety interlocks, these must be wired in series.

Warning: On no account must the route of the cables allow them to contact any unprotected or un-insulated surface. All cables between economiser, boiler and controls must be routed in accordance with IEE regulations.

Arne Eco Turbo - model		400	620	940	1430
ELECTRICAL DATA					
Motor power	kW	0.25	0.75	1.5	3
Motor speed	rpm	1500	1500	1500	1500
Fuse load	A	3.5	4.5	5	5

Figure B.1 - Electrical data Arne Eco Turbo

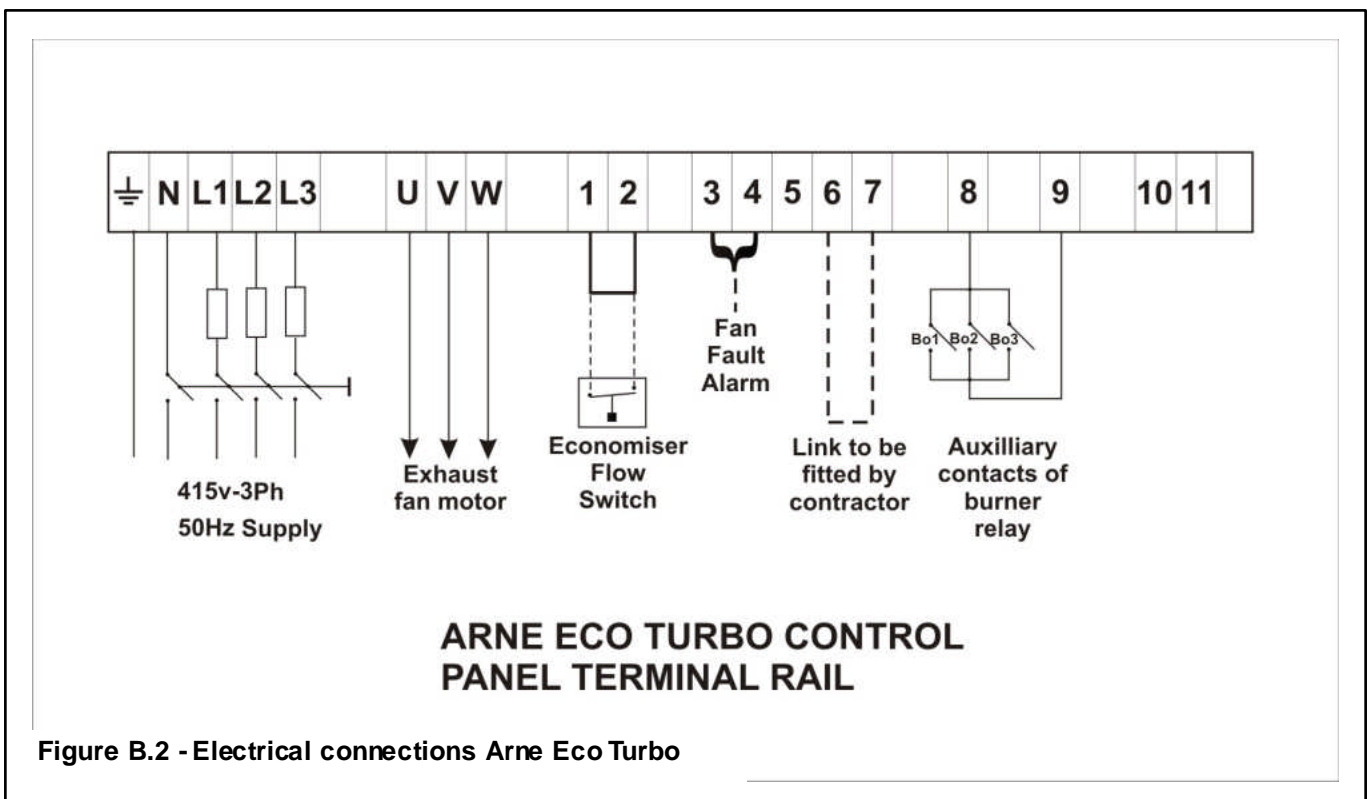

Figure B.2 - Electrical connections Arne Eco Turbo

APPENDIX C - FLUE DATA

C 1 General Requirements

Detailed recommendations for flue systems are given in **BS 6644, IGE/UP/10**, "Flues for Commercial and Industrial Gas-Fired Boilers and Air Heaters."

The following notes are intended to give general guidance only.

C.1.1 The flue passages within the Arne Eco economiser range operate under pressurised conditions and in order to eliminate any additional resistance, it is recommended that the flue system shall be adapted to its design diameter as soon as possible.

C.1.2 The Arne Eco models are designed for direct connection into the flue system of a single or modular boiler system and must be sized for the maximum firing rate of the boiler(s).

The Arne Eco Turbo models should be installed in parallel to the flue system

C.1.3 The boiler should be connected to a single flue system in the case of a single boiler, or a common flue header in the case of a multiple boiler installation. Flue systems must be self supporting, contain access for cleaning and contain a maintenance joint near the boiler outlet to allow for removal of the flue box during servicing.

Consult Hamworthy Heating Technical Department for help or assistance if in doubt.

C.2 Design Waste Gas Volume and Temperature

It is recommended that the volume and temperature of the waste gases used for design of the flue system are as shown in Figures A1, A2 & A3

C.3 Materials

Materials used for the flue system must be mechanically robust, resistant to internal and external corrosion, non-combustible and durable under the conditions to which they are likely to be subjected.

Consideration should be given to possible freezing of condensate water traps and pipework. This must be avoided at all times. Insulate condensate pipes if freezing temperatures are likely to be encountered.

Chimneys should be lined with a non-porous acid-resistant material in accordance with BS.5854, e.g. a flexible flue liner or similar British Gas Approved material. The internal diameter of the liner must not be less than the recommended flue size and the number of joints should be kept to a minimum.

Any joint between the flexible liner and the flue connection to the economiser should be made using a purpose made connector. Existing chimneys should be thoroughly swept before use and any register plates, dampers, or restrictions removed.

If the boiler(s) is not connected to a chimney system, but is connected directly to outside by a standard stainless steel flue (either single or twin wall) it is particularly important to ensure that the

point at which it exits the building is fully weatherproofed.

C.4 Suction

The flue system should be designed to maintain atmospheric pressure or a slight suction at the economiser flue connection at all times (0.1 - 0.3mbar).

It is recommended that a draught stabiliser is fitted to the flue system where the suction is likely to exceed 0.3mbar.

C.5 Disconnection

Provisions should be made for disconnection of the flue pipe for servicing. It is advisable that bends are fitted with removable covers for inspection and cleaning as appropriate. **NOTE!** The flue system must be self supporting and not present a risk to people in or around the building.

C.6 Flue Discharge

The flue system must ensure safe and efficient operation of the boiler to which it is attached, protect the combustion process from wind effects and disperse the products of combustion to the external air.

The flue must terminate in a freely exposed position and be situated so as to prevent the products of combustion entering any opening in a building. Consideration should be given to the fitting of a flue discharge terminal or grille to stop the ingress of birds etc.

The flue system should be designed such that the flue terminates at least 1 metre above the roof surface, or above the level of any nearby structure which is within 2.5 metres of the flue.

C.7 Surface Temperatures

Combustible materials in the vicinity of the boiler and flue shall not exceed 65 °C during boiler operation. The flue shall not be closer than 50mm to any combustible material, except where it passes through such material with a non-combustible sleeve when the air gap may not be less than 25mm.

C.8 Flue System Location

The flue system must not be placed or fitted where there is undue risk of accidental damage to the flue pipe or undue danger to persons in the vicinity. **NOTE!** The flue **MUST** be self supporting. Check that the flue and chimney are clear from any obstruction.

C.9 Condensate Discharge

When designing the flue system, care must be taken to ensure that any condensate which may form within the system, can be safely drained to a suitable waste point and, that the flue material used is resistant to the corrosive effects of that condensate.

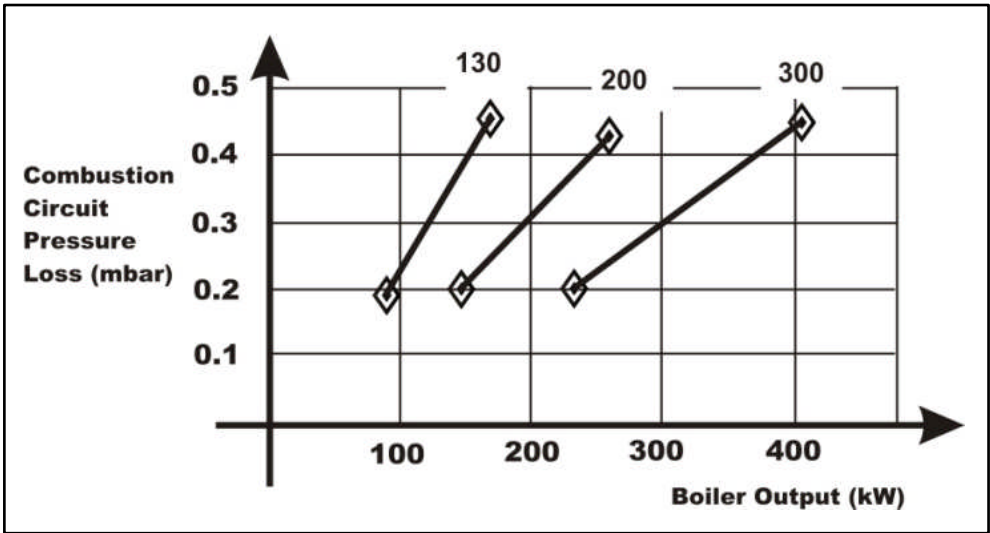

Figure C.1 – Arne Eco Combustion Circuit Information - (models 130 - 300)

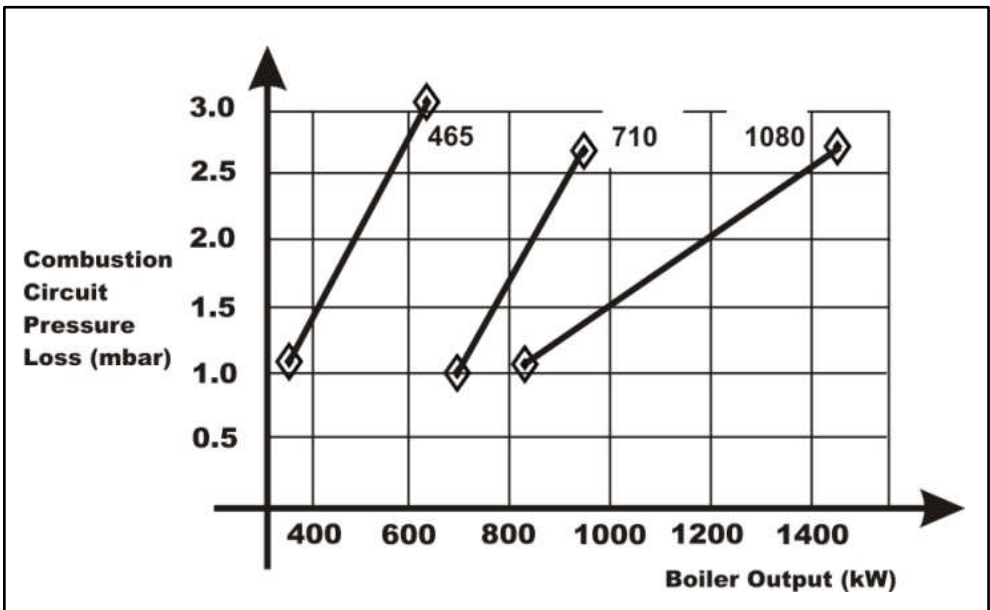

Figure C.2 – Arne Eco Combustion Circuit Information - (models 465 - 1080)

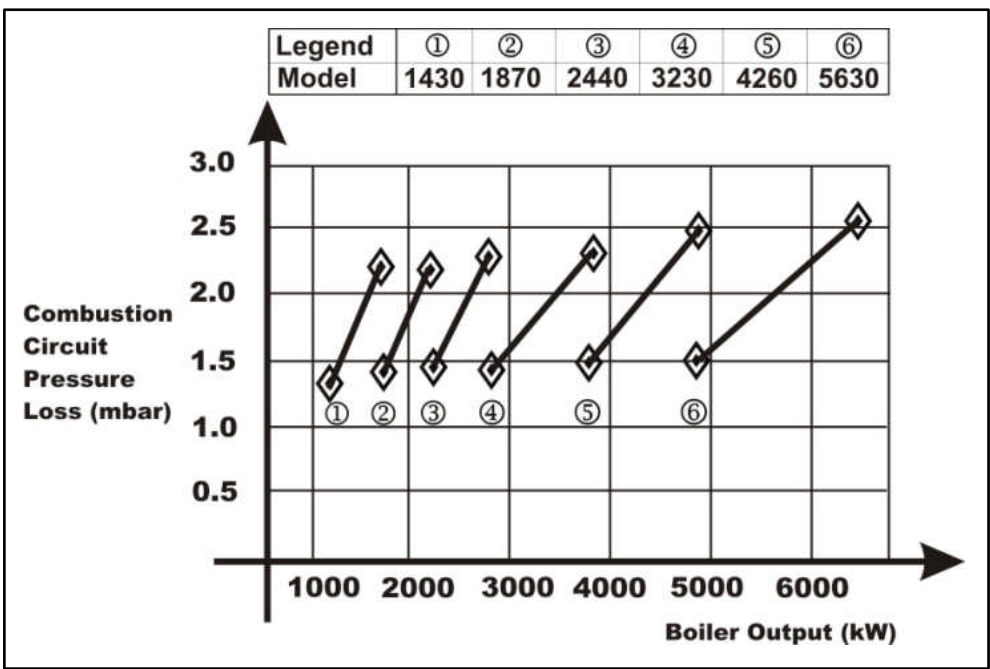

Figure C.3 – Arne Eco Combustion Circuit Information - (models 1430 - 5630)

Note: - the Arne Eco combustion circuit pressure loss is additional to the combustion circuit pressure loss through the boiler at the firing rate.

APPENDIX D - VENTILATION

Refer to the boiler Instruction for clarification of ventilation requirements

APPENDIX E - WATER DATA

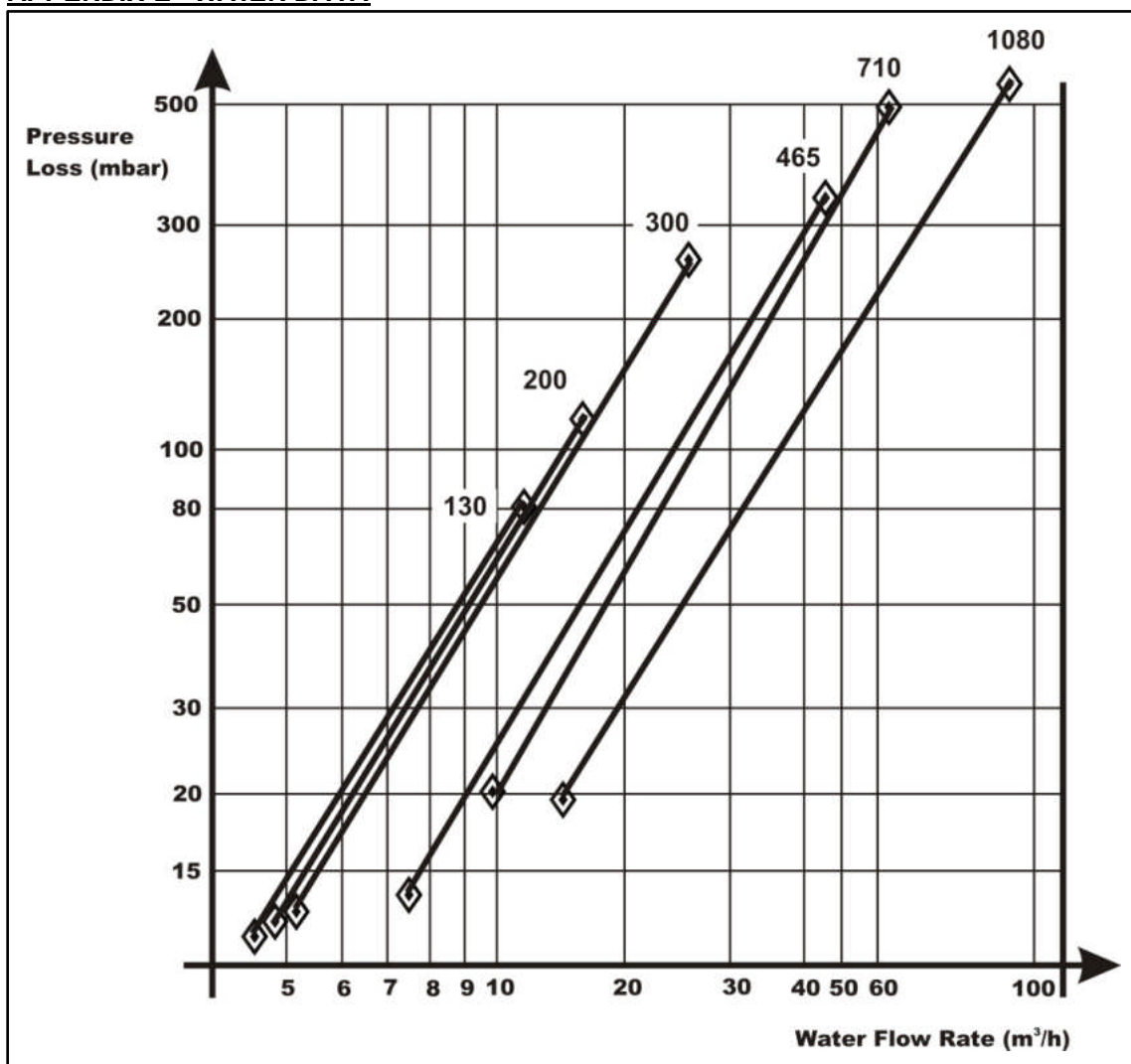

Figure E.1 – Arne Eco Hydraulic Circuit Information - (models 130 - 1080)

E 1 Water circulation system

Recommendations for the water circulation system are given in **BS 6644** for gas fired boilers but the same principals can be used for those using fuel oil. The following notes are of particular importance:-

E1.1 In a combined central heating and hot water system, the hot water storage vessel must be of the indirect cylinder or calorifier type. The hot water storage vessel should be insulated preferably with not less than 75mm (3 in) thick mineral fibre, or its thermal equivalent.

E1.2 Circulating pipework not forming part of the useful heating surface should be insulated to help prevent heat loss and possible freezing, particularly where pipes are run through roof spaces and venti-

lated cavities. Cisterns situated in areas, which may be exposed to freezing conditions, should also be insulated. Insulation exposed to the weather should be rendered water-proof.

E1.3 Flanged flow and return connections are provided for both economiser and boiler.

E1.4 Multiple boilers should be connected by flow and return headers. Headers should be connected to the system in a "reverse return" arrangement (the water flow in each header is in the same direction) to ensure equal flow in each boiler.

E1.5 A coarse filter and dirt separator **MUST** be fitted in the return to both primary and secondary heat exchangers

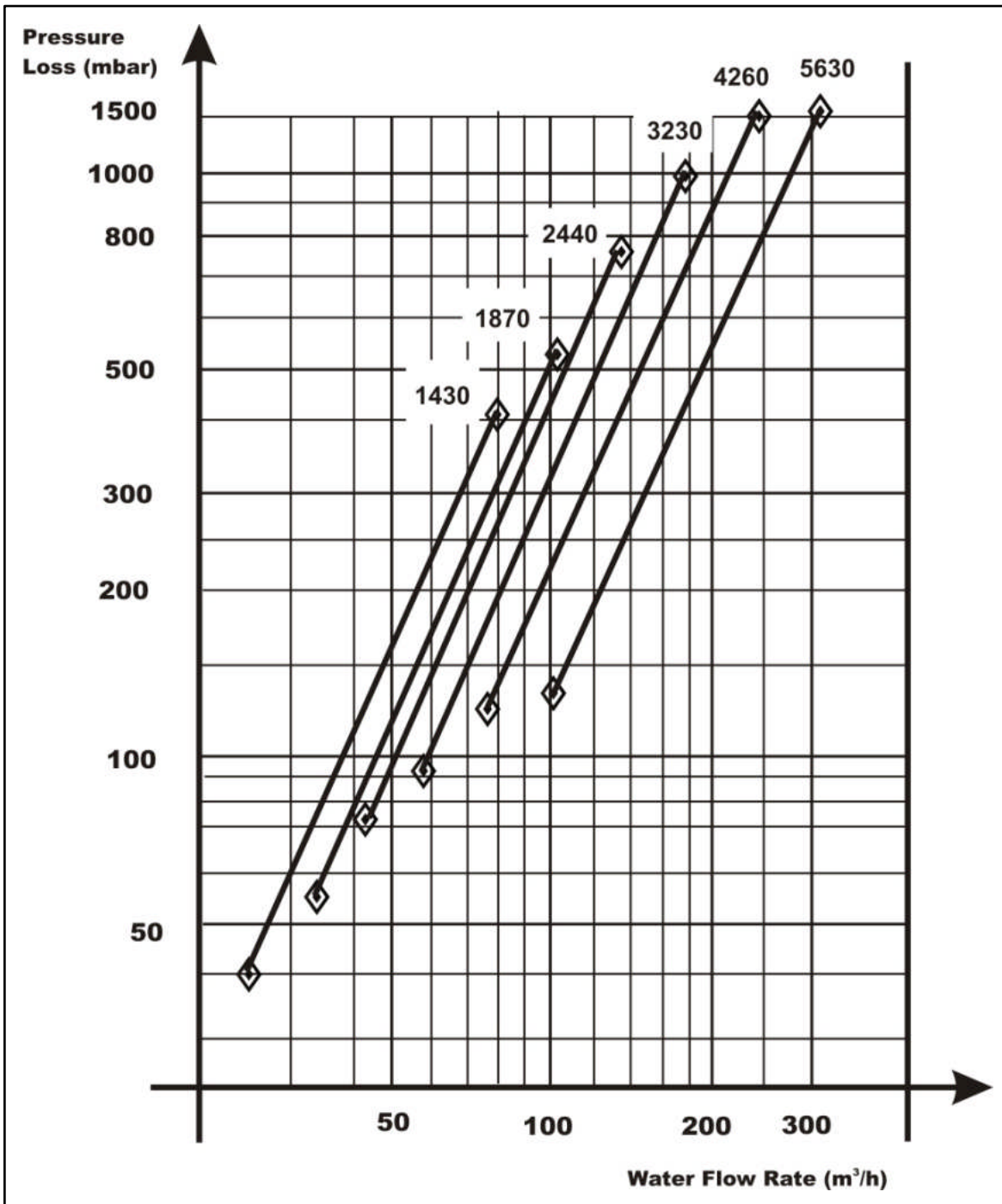

Figure E.2 – Arne Eco Hydraulic Circuit Information - (models 1430 - 5630)

E.2 Pressure Relief Valve (Safety Valve)

The most important single safety device fitted to a boiler is its safety valve and each boiler, or in the case of a multiple installation, each bank of boilers, must be fitted with a pressure relief valve to **BSEN-**

ISO 4126-1 and sized as shown in **BS 6644**.

Each boiler and economiser has a tapping on the flow pipe for the fitting of a safety valve to the boiler.

BS 6644 provides comprehensive information for the selection and location of safety valves and attention is drawn to the higher capacity requirements of safety valves for pressurised hot

water systems.

E.3 Open Vent and Cold Feed Pipe

(See **BS 6644** for further information.)

Every boiler or group of boilers should have an open vent pipe and cold feed pipe installed between the boiler and the first water isolating valve. The minimum bore (mm) of these pipes is detailed in the boiler instruction manual.

The vent pipe must rise continually, must not be valved except by a design which when dosed for maintenance the boiler is open to atmosphere. The pipe shall be protected against freezing where this might occur.

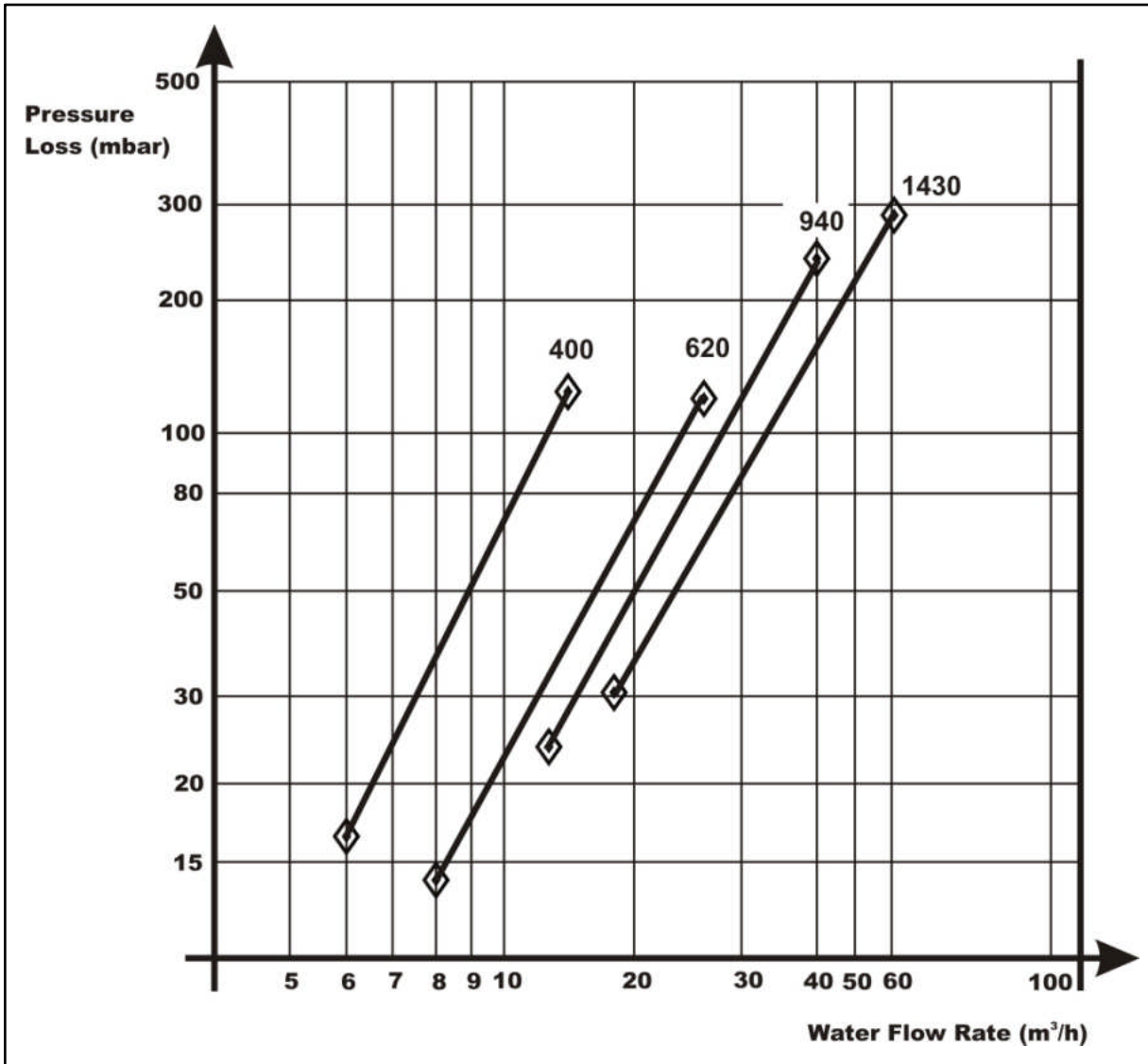

Figure E.3 – Arne Eco Turbo Hydraulic Circuit Information

E.4 Altitude Gauge (Water Pressure Gauge)

Every boiler or group of boilers should be provided with a gauge complete with isolating valve.

E.5 Thermometer

A thermometer complete with pocket should be fitted in the pipework to indicate water flow temperature.

E.6 Drain Valves

Each economiser should have a drain valve fitted (not H.H.L. supply), to the appropriate connection on the return pipe of the economiser.

The heating system in total should have drain valves as recommended by **BS 6644** which permit the draining of the whole system, including the boiler and any hot water storage vessel.

E.7 Circulating Pump

One or more circulating pumps will be required to circulate water around the boilers and heating

system. The pump should be sited to facilitate servicing.

7.9 Waterside Pressure Drop

The waterside hydraulic resistance (Pressure drop) is shown in Figure E1.

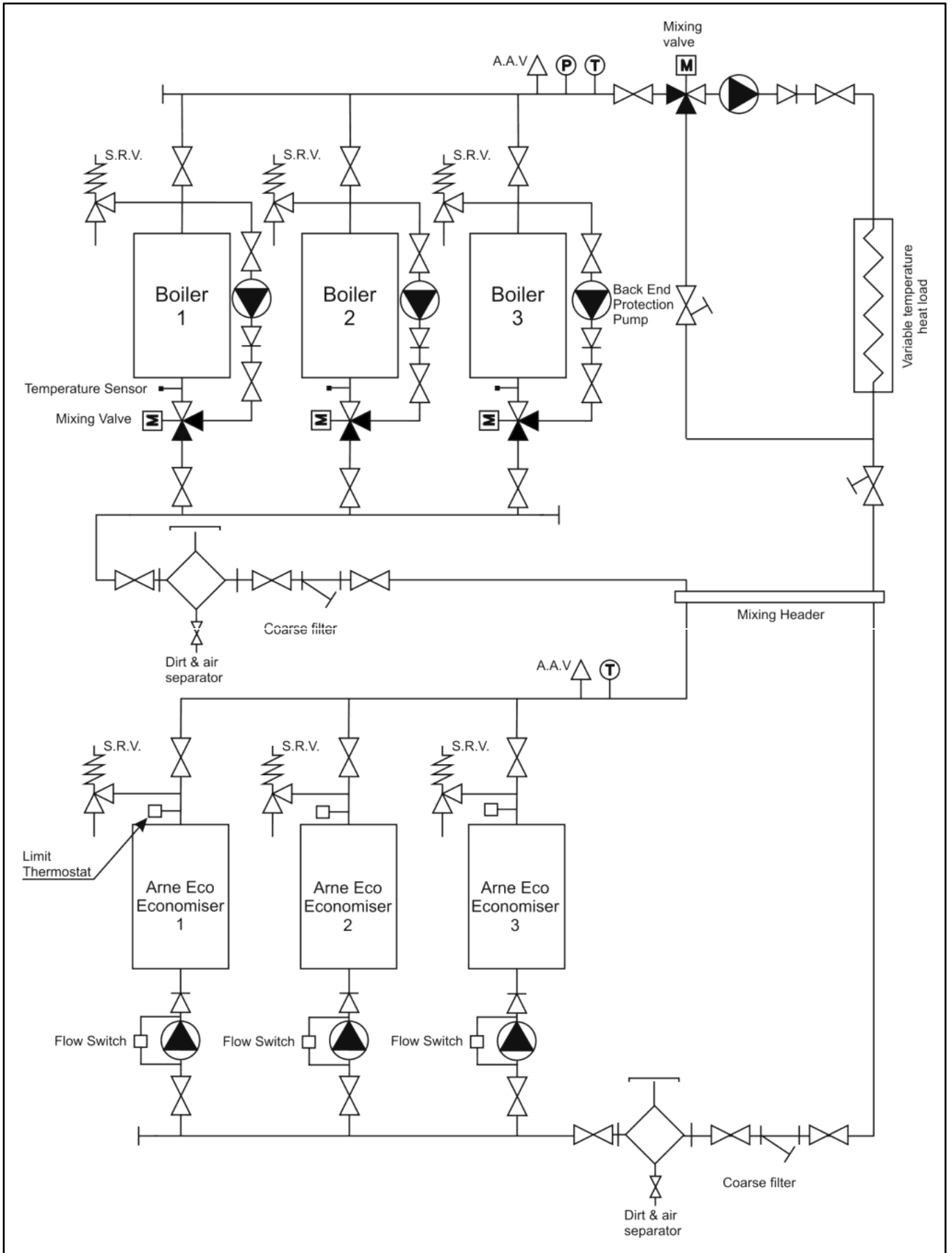

Figure E.4 - Arne Eco Hydraulic schematic - dedicated Economiser for each boiler

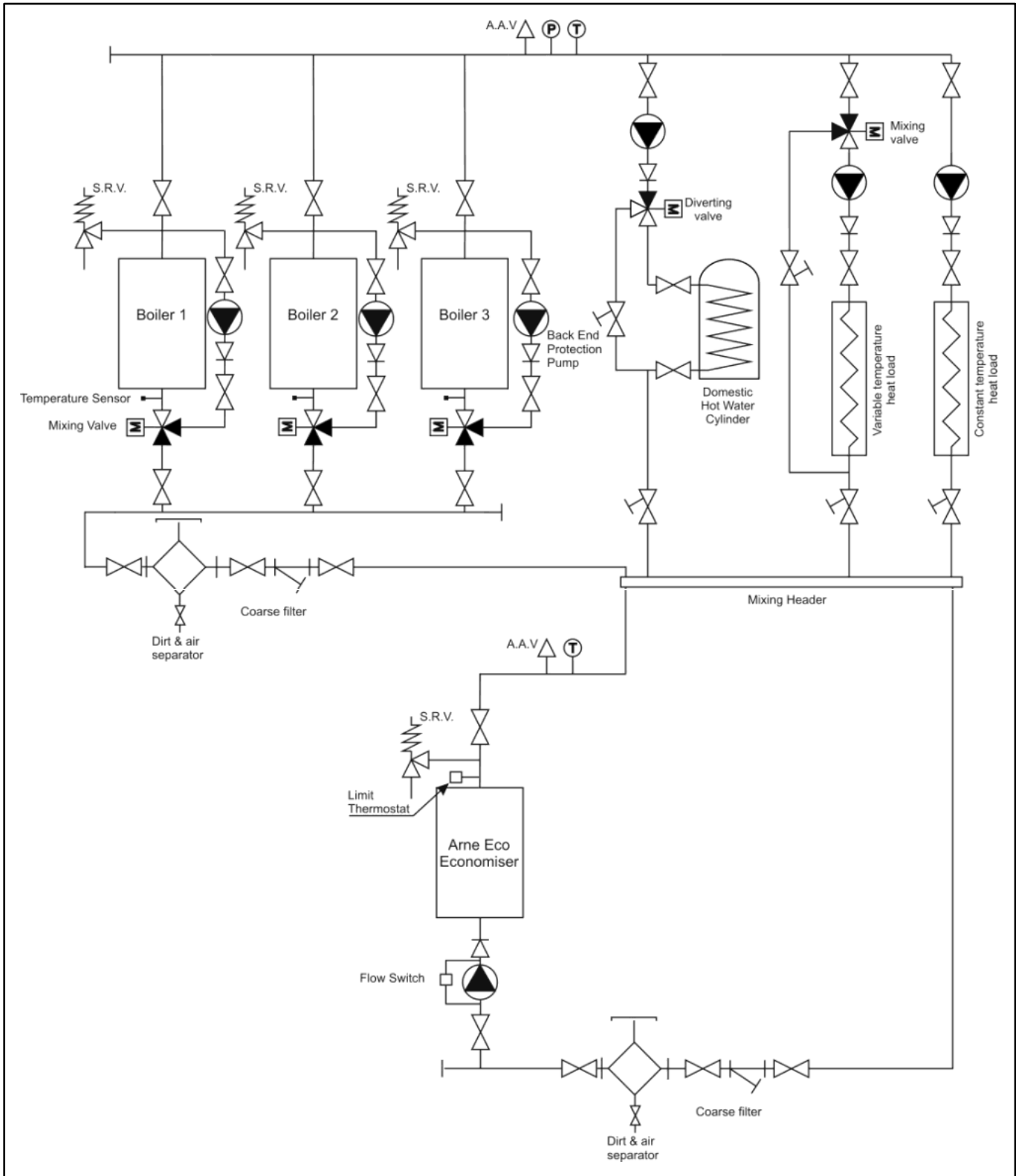

Figure E.5 - Arne Eco Hydraulic schematic - single Economiser for multiple boilers

USEFUL USER INFORMATION

INSTALLER		SITE ADDRESS		

BOILER TYPE	BOILER SIZE(S)	UNIT NO(S).	SERIAL NO(S).	FLUE

Notes

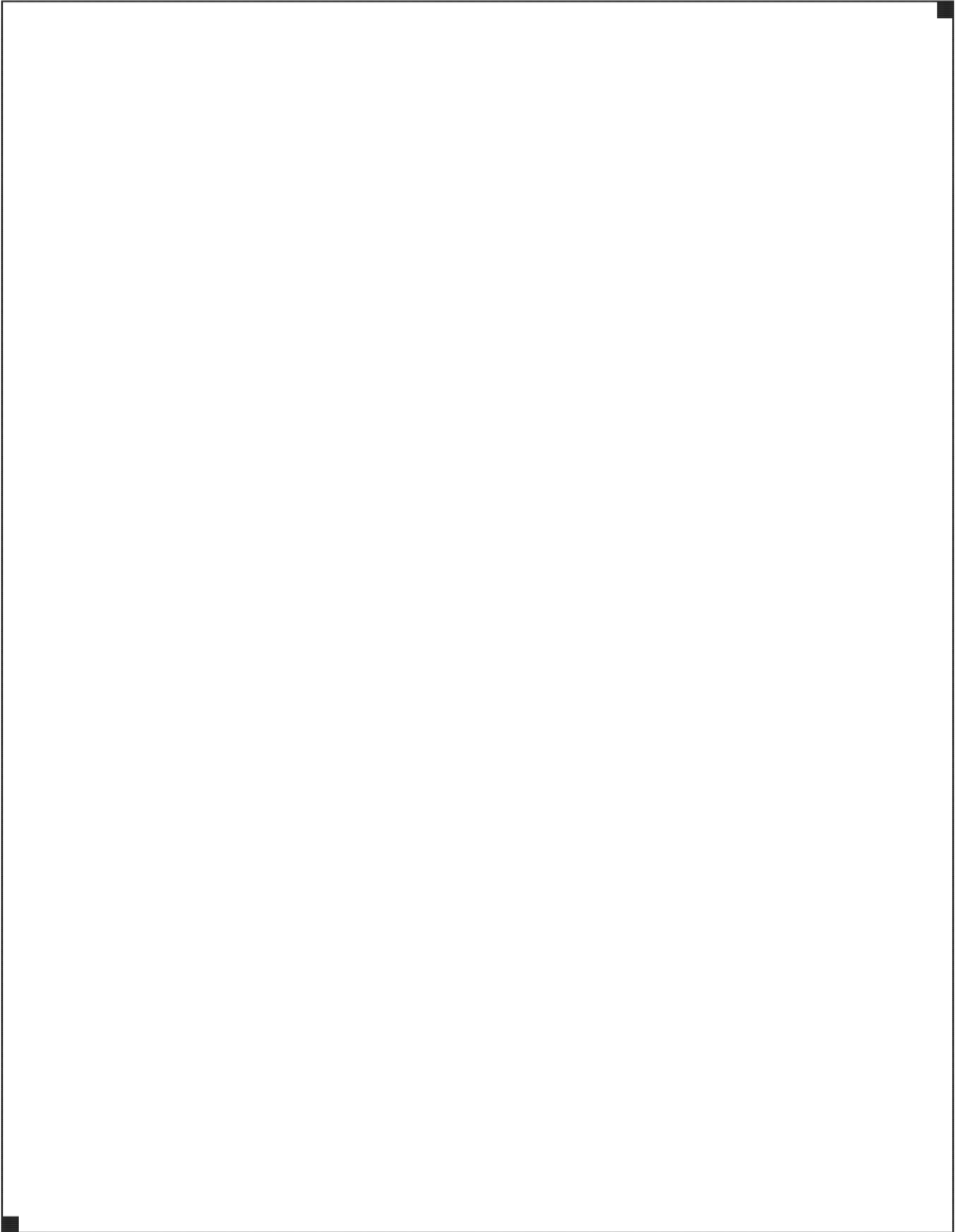
A large empty rectangular box with a thin black border, intended for notes. It has small black squares at the top-right and bottom-left corners.

Hamworthy Heating Accredited Agents

Southern Ireland (Sales & Service)

HEVAC Limited
Naas Road, Dublin 12, Ireland
tel: **00 353 141 91919** fax: **00 353 145 84806**
email: **info@hevac.ie**

Scotland (Sales & Service)

McDowall Modular Services
2 Penson Road, Queenslie Industrial Estate, Glasgow, G33 4AG
tel: **0141 336 8795** fax: **0141 336 8954**
email:
MMS.McDowallModularServices@hamworthy-heating.com

Northern Ireland (Sales & Service)

HVAC Supplies Limited
Unit A6, Dargan Court, Dargan Crescent, Belfast BT3 9JP
tel: **028 9077 7737**
email: **hvacsupplies@btconnect.com**

North East England (Service)

Allison Heating Products
12 Sunnyside Lane, Cleadon Village, Sunderland SR6 7XB
tel: **0191 536 8833** fax: **0191 536 9933**
email: **allison.heating@gmail.com**

Hamworthy Heating Customer Service Centre

Sales

tel: **01202 662552**
email: **sales@hamworthy-heating.com**

Technical Enquiries

tel: **01202 662505**
email: **technical@hamworthy-heating.com**

Servicing

tel: **01202 662555**
email: **service@hamworthy-heating.com**

Spares

tel: **01202 662525**
email: **spares@hamworthy-heating.com**

British engineering excellence from Hamworthy Heating;
the commercial heating and hot water specialists.



Customer Service Centre

Hamworthy Heating Limited,
Wessex House,
New Fields Business Park,
Stinsford Road,
Poole,
Dorset,
BH17 0NF

Telephone: **01202 662500**
Fax: **01202 662522**
Email: **service@hamworthy-heating.com**
Website: **www.hamworthy-heating.com**