

PREMIUM

Versatility of a wide range of water heaters
with O'Pro protection technology
for +50% tank lifetime

Thermor

CHARACTERISTICS

COMFORT

- Control knob on the bottom of the tank
- Flat chromed thermometer

QUALITY - DURABILITY

- Long tank lifetime thanks to O'Pro exclusive anti-corrosive system
- Magnesium anode for strengthened tank protection
- New generation diamond-quality enamel (glass-lined inner tank)
- Pressure relief valve
- Dielectric union
- Specific lip gasket to avoid corrosion around flange

USER-FRIENDLINESS

- IP 24 - full compliance with European standards for electrical safety and user protection
- Plug*
- Heating light indicator

SAVINGS

- High-efficiency water inlet
- CFC-free high-density insulation for more energy savings



ELECTRIC WATER HEATER

50 TO 200 L

(Vertical wall-mounted)

80 TO 100 L

(Horizontal wall-mounted)

200 TO 300 L

(Floor-standing)



Models available**



+50%

Tank lifetime



Technology

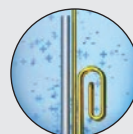

Heating element



Energy efficiency
class C

*Depending on models.

**Model types: 1. Vertical wall-mounted - 2. Horizontal wall-mounted - 3. Floor-standing.

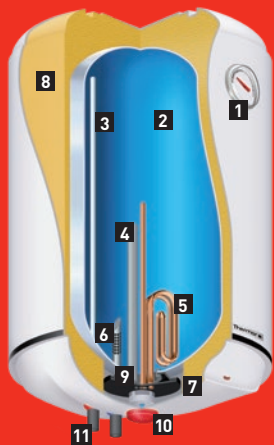

- 1 External thermometer
- 2 Diamond-quality enamel
- 3 Optimised stainless steel outlet pipe
- 4 Magnesium anode
- 5 Sheathed immersion heating element
- 6 Inlet diffuser
- 7 Thermostat
- 8 High-density polyurethane foam 0% CFC
- 9 O'Pro anti-corrosive system
- 10 Bottom control knob
- 11 Dielectric union

BOTTOM CONTROL KNOB



INSTALLATION DIMENSIONS (in mm)

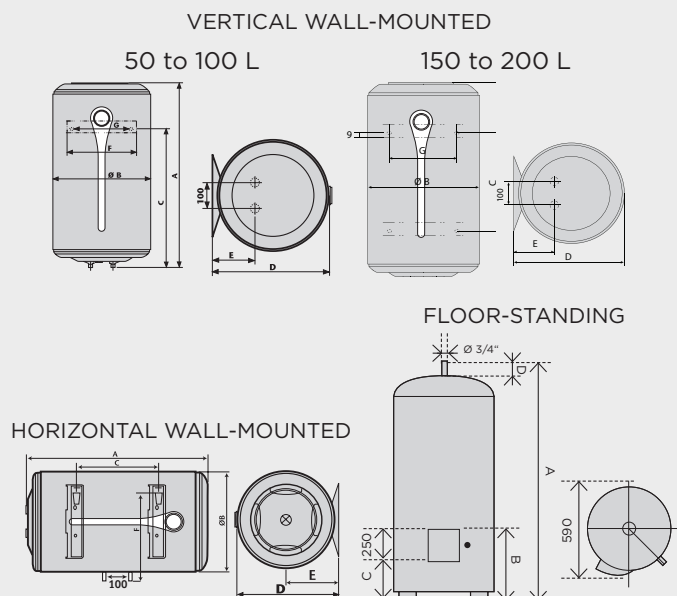

TECHNICAL DATA

Capacity (L)	Output (W)	Voltage (V)	Energy consumption (kWh/24h at 65°C)	Heat-up time at 60°C (Δt=50°C)	Hot water capacity at 40°C
Premium (Vertical wall-mounted)					
50	2000	230 (220/240)	0.95	1h25	-
80	2000	230 (220/240)	1.40	2h34	-
100	2000	230 (220/240)	1.85	3h05	-
150	1600	230 (220/240)	1.61	6h00	-
200	2200	230 (220/240)	1.92	6h01	-
Premium (Horizontal wall-mounted)					
80	1500	230 (220/240)	1.55	2h53	-
100	1500	230 (220/240)	1.95	3h58	-
Premium (Floor-standing)					
200	2200	230 mono	1.91	4h55	360
250	3000	230 mono	2.18	4h32	443
300	3000	230 mono	2.50	5h43	531

DIMENSIONS

Capacity (L)	Dimensions (mm)								Flange opening (Ø mm)	Net weight (kg)	ERP Energy class	Profile
	Ø	A	B	C	D	E	F	G				
Premium (Vertical wall-mounted)												
50	-	612	433	382	451	158	300	239	72	15	C	M
80	-	859	433	592	451	158	300	239	72	21	C	L
100	-	1021	433	742	451	158	300	239	72	24	C	L
150	-	1224	505	800	530	169	-	440	72	41	C	M
200	-	1570	513	800	540	171	-	440	72	50	C	L
Premium (Horizontal wall-mounted)												
80	-	843	433	349	451	228	346	-	72	21	C	M
100	-	1005	433	497	451	228	346	-	72	24	C	L
Premium (Floor-standing)												
200	575	1275	270	160	30	-	-	-	-	51	C	M
250	575	1500	270	160	30	-	-	-	-	63	C	L
300	575	1780	270	160	30	-	-	-	-	73	C	L

CE | EAC | IP 24



Thermor