

Tyneham Heat Pump 26 & 32kW



A++
ErP rating

5
Yr
Warranty*

4.09
COP

R32
Refrigerant

As low as
74
dB(A)

Key benefits:

- > Monobloc air source heat pump
- > Single unit with the refrigeration cycle contained within the outdoor unit
- > Inverter controlled compressor to accurately match the heat demand
- > Low global warming potential due to the use of R32 refrigerant
- > Highly efficient with coefficient of performance (COP) rating up to 4.09
- > Light and compact unit for ease of installation and delivery
- > Suited to larger installations - cascade systems to achieve higher output.
- > 2-year warranty (extended to 5 years if commissioned by Hamworthy)*
- > Blue Fin anti-corrosion coating as standard
- > Back up and long-term support from our team of experienced engineers across the UK
- > Combine with Hamworthy modular boilers for a hybrid heating system

Technical Specification	Unit	26kW	32kW
Heat Pump Space Heating [35°C]	ErP rating	A++	A++
	SCOP	4.55	4.81
Heat Pump Space Heating [55°C]	ErP rating	A+	A+
	SCOP	3.14	3.14
Heating (A7/W35)	Capacity (kW)	26	32.1
	Power Input (kW)	6.44	7.84
	COP***	4.04	4.09
Air Temperature Range	Min/Max (°C)	(-20 +40)	(-20 +40)
Sound Data Outdoor Unit	Power Level dB(A)**	74	76
Pipework Connection Sizes	Heating Flow (")	1	1 1/4
	Heating Return (")	1	1 1/4
Dimensions Outdoor Unit	Width (mm)	1600	1600
	Depth (mm)	680	680
	Height (mm)	1315	1315
Weight	kg	240	255
Electrical Data	Electrical Supply (v)	415	415
	Phase	Three	Three
	Max Running Current (Amp)	23.3	27.1
	Fuse Rating (Amp)	25	32
Refrigerant Charge (kg)	R32 (kg)	4.3	5.1



[hamworthy-heating.com](https://www.hamworthy-heating.com)

sales@hamworthy-heating.com | 01202 662500



* 2 year warranty extended to 5 years if commissioned by Hamworthy Heating. ** 74dB(A) is the rated sound pressure level of the Tyneham 26kW, Tyneham 32kW is rated at 76dB(A), the sound levels refer to a fully loaded unit at standard nominal conditions according to EN 12102-1: 2013. *** Efficiency coefficient of performance (COP) rated at EN14825 test conditions Water 35°C, Air 7°C. Every effort has been taken to ensure the details are accurate. Hamworthy Heating does not, however, guarantee the accuracy or completeness of any information nor does it accept liability for any errors or omissions in the information. Hamworthy Heating reserves the right to make changes and improvements which may necessitate alteration to product specification without prior notice.

Tyneham Heat Pump 26 & 32kW



Dimensions

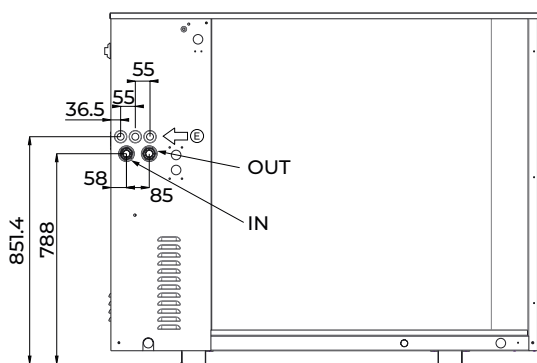
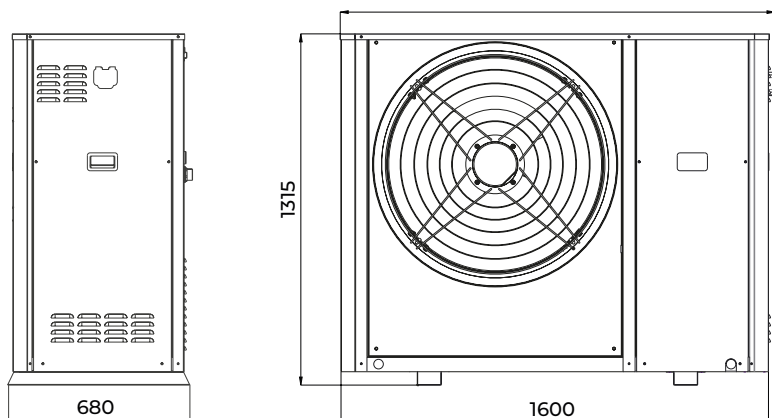

E: Electrical Connection

Note: All dimensions in mm unless otherwise stated.

Minimum installation clearances:

Front: 1500

Rear: 400

Left: 400

Right: 700

Bottom: 50

Side clearance of 700mm when used in cascade

Accessories and options:

	Required	Optional
Control unit (sold separately)*		•
Flexible hoses		•
Anti-vibration rubber feet		•
Anti-corrosion coating for installations close to the sea (special order)		•

hamworthy-heating.com

sales@hamworthy-heating.com | 01202 662500



*Optional control units are available for cascade and additional heating circuits, and where no BMS is present.