

STEATITE PRO

Durability of the Steatite technology
with very accurate controls

Thermor 

CHARACTERISTICS

COMFORT

- Control knob on the front of the tank
- Flat chromed thermometer*

QUALITY - DURABILITY

- Steatite technology: Ceramic dry heating element adapted to aggressive, highly mineralised or desalinated water
- Magnesium anode for strengthened tank protection
- New generation diamond-quality enamel (glass-lined inner tank)
- Pressure relief valve
- Dielectric union
- Specific lip gasket to avoid corrosion around flange

USER-FRIENDLINESS

- IP 24 - full compliance with European standards for electrical safety and user protection
- Plug*
- Heating light indicator

SAVINGS

- Accurate controls ensured by highly sensitive thermostat
- High-efficiency water inlet
- CFC-free high-density insulation for more energy savings



ELECTRIC WATER HEATER

50 TO 200 L
(Vertical wall-mounted)

200 TO 300 L
(Floor-standing)



Models available**



Heating element



Controls



Energy efficiency
class C

*Depending on models.

**Model types: 1. Vertical wall-mounted - 2. Horizontal wall-mounted - 3. Floor-standing.

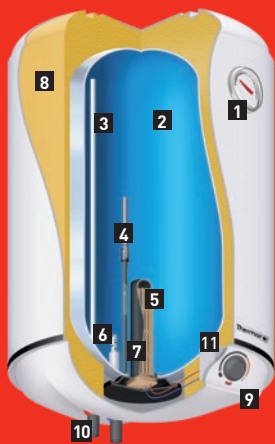

- 1 External thermometer
- 2 Diamond-quality enamel
- 3 Optimised stainless steel outlet pipe
- 4 Magnesium anode
- 5 Steatite dry heating element
- 6 Inlet diffuser
- 7 Enamelled sleeve
- 8 High-density polyurethane foam 0% CFC
- 9 Frontal control knob*
- 10 Dielectric union
- 11 Thermostat

FRONTAL CONTROL KNOB



INSTALLATION DIMENSIONS (in mm)

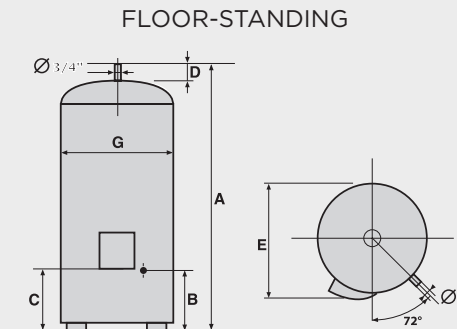
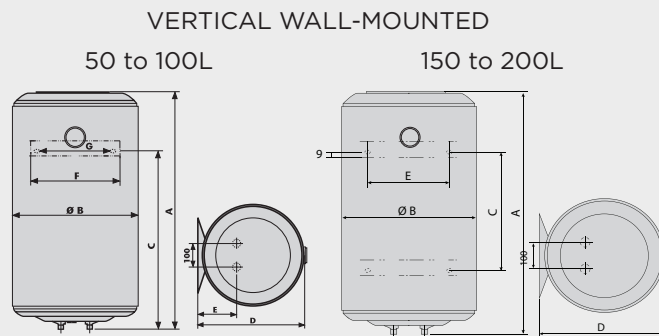

TECHNICAL DATA

Capacity (L)	Output (W)	Voltage (V)	Energy consumption (kWh/24h at 65°C)	Heat-up time at 60°C (Δt=50°C)
Steatite Pro (Vertical wall-mounted)				
50	1500	230 (220/240)	0.95	1h59
80	1500	230 (230/240)	1.35	3h19
100	1500	230 (220/240)	1.70	4h24
150	1800	230 (220/240)	1.59	5h16
200	2400	230 (220/240)	1.94	5h20
Steatite Pro (Floor-standing)				
200	2400	230 (220/240) / 400 V-3	1.95	4h45
300	3000	230 (220/240) / 400 V-3	2.5	6h06

DIMENSIONS

Capacity (L)	Dimensions (mm)							Flange opening (Ø mm)	Net weight (kg)	ERP Energy class	Profile
	A	B	C	D	E	F	G				
Steatite Pro (Vertical wall-mounted)											
50	629	433	395	451	158	300	239	72	15	C	M
80	876	433	605	451	158	300	239	72	21	C	L
100	1038	433	755	451	158	300	239	72	24	C	L
150	1220	505	800	520	440	-	-	-	41	C	M
200	1550	505	800	525	440	-	-	-	51	C	L
Steatite Pro (Floor-standing)											
200	1275	270	160	30	590	-	575	82	51	C	M
300	1780	270	160	30	590	-	575	82	73	C	L

CE | EAC | IP 24



* Only for vertical wall-mounted models