

# E-Series

WATER HEATER EQUIPPED WITH A MAGNESIUM ANODE AND AN IMMERSION DIRECT HEATING ELEMENT



## + PRODUCT

### QUALITY - DURABILITY





- Magnesium anode for strengthened tank protection
- New generation diamond-quality enamel (glass-lined inner tank)
- Pressure relief valve
- Dielectric union
- Specific lip gasket to avoid corrosion around flange
- Rod type thermostat (regulation + manual reset safety cut-out)
- Flange type heating element

### USER-FRIENDLINESS

- IP 24 or IP 25 - full compliance with European standards for electrical safety and user protection
- Heating light indicator

### SAVINGS

- Mechanical thermostat with integrated security
- High-efficiency water inlet
- CFC-free high-density insulation for more energy savings

ELECTRIC WATER HEATER		30 TO 100 L (VERTICAL WALL-MOUNTED)	50 TO 100 L (HORIZONTAL WALL-MOUNTED)
 <p>Model available*</p>	 <p>Warranty</p>	<p>MAGNESIUM ANODE</p> <p>Tank protection</p>	 <p>More hot water</p>
			 <p>GCC energy regulation</p>

\* Model types: A: Vertical wall-mounted / B: Horizontal wall-mounted / C: Floor-standing

# E-series



- 1 Diamond-quality enamel (glass-lined inner tank)
- 2 Optimised stainless steel outlet pipe
- 3 Magnesium anode
- 4 Inlet diffuser
- 5 CFC-free high density insulation foam
- 6 Sheathed immersion heating element
- 7 Thermostat with manual reset safety cut-out
- 8 Heating light indicator
- 9 External thermometer
- 10 Bracket for wall-mounting

## INSTALLATION DIMENSIONS

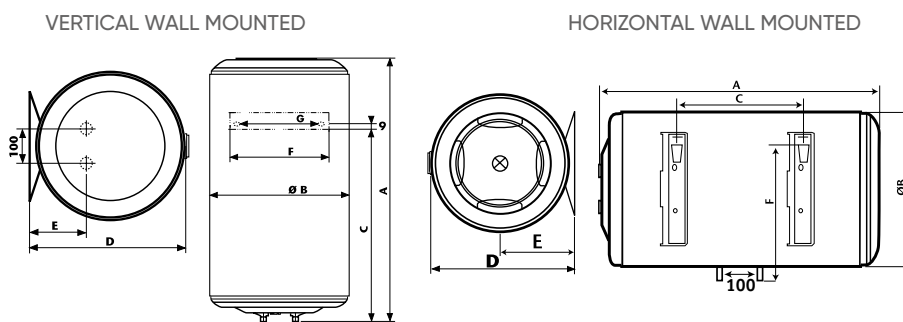

## TECHNICAL DATA

CAPACITY (L)	OUTPUT (W)	VOLTAGE (V)	HEAT-UP TIME AT 60°C (ΔT=20°C)	HEAT-UP TIME AT 60°C (ΔT=50°C)	ENERGY CONSUMPTION (KWH/24H AT 65°C)
<b>E-Series Vertical wall-mounted</b>					
30	1200	230 (220/240)	0h36	1h12	0.646
50	1500	230 (220/240)	0h48	1h53	0.913
80	1500	230 (220/240)	1h17	3h09	1.282
100	1500	230 (220/240)	1h36	3h48	1.55
<b>E-Series Horizontal wall-mounted</b>					
50	1500	230 (220/240)	0h40	1h40	0.945
80	1500	230 (220/240)	1h06	2h45	1.216
100	1500	230 (220/240)	1h28	3h40	1.67

## DIMENSIONS

CAPACITY (L)	DIMENSIONS (mm)							FLANGE OPENING (Ø) mm	NET WEIGHT (Kg)	ERP ENERGY EFFICIENCY CLASS
	A	B	C	D	E	F	G			
<b>E-Series Vertical wall-mounted</b>										
30	448	433	235	451	165	300	240	72	11	★★★★★
50	612	433	380	451	165	300	240	72	15	★★★★★
80	859	433	590	451	165	300	240	72	20	★★★★★
100	1021	433	740	451	165	300	240	72	24	★★★★★
<b>E-Series Horizontal wall-mounted</b>										
50	596	433	160	451	234	343	-	-	15	★★★★★
80	848	433	335	451	234	343	-	-	21	★★★★★
100	1005	433	510	451	234	343	-	-	24	★★★★★

IP 24 - IP 25  
Horizontal Vertical